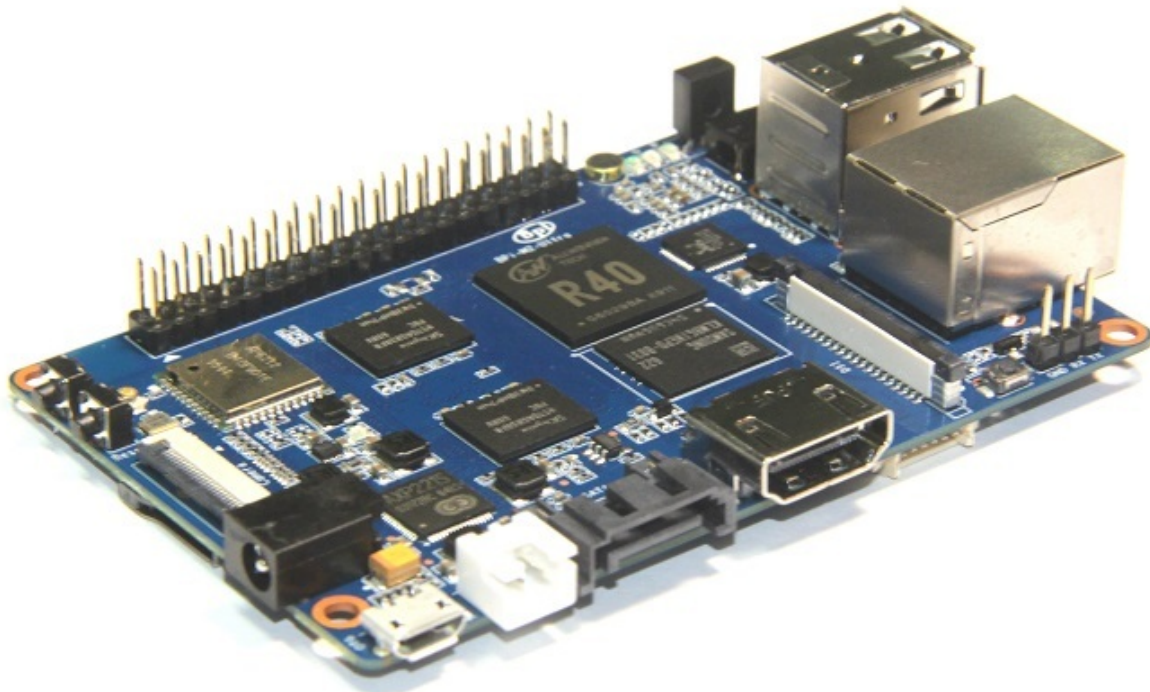

Table of Contents

About BPI-M2 Ultra/BPI-M2 Berry	1.1
BPI-M2 Berry hardware	1.2
BPI-M2 Berry hardware interface	1.2.1
BPI-M2 Berry hardware spec	1.2.2
BPI-M2 Berry GPIO Pin define	1.2.3
BPI-M2 Berry SATA interface	1.2.4
BPI-M2 Berry micro SD card slot	1.2.5
BPI-M2 Berry GigE LAN	1.2.6
BPI-M2 Berry WIFI interface	1.2.7
BPI-M2 Berry wifi antenna slot	1.2.8
BPI-M2 Berry HDMI interface	1.2.9
BPI-M2 Berry USB interface	1.2.10
BPI-M2 Berry OTG interface	1.2.11
BPI-M2 Berry bluetooth interface	1.2.12
BPI-M2 Berry UART port	1.2.13
BPI-M2 Berry MIPI DSI interface	1.2.14
BPI-M2 Berry CSI camera interface	1.2.15
BPI-M2 Berry Power interface	1.2.16
BPI-M2 Berry DXF and 3D design	1.2.17
BPI-M2 Berry schematic diagram	1.2.18
BPI-M2 Ultra hardware	1.3
BPI-M2 Ultra hardware interface	1.3.1
BPI-M2 Ultra hardware spec	1.3.2
BPI-M2 Ultra GPIO Pin define	1.3.3
BPI-M2 Ultra SATA interface	1.3.4
BPI-M2 Ultra micro SD card slot	1.3.5
BPI-M2 Ultra GigE LAN	1.3.6
BPI-M2 Ultra eMMC flash	1.3.7
BPI-M2 Ultra WIFI interface	1.3.8
BPI-M2 Ultra wifi antenna slot	1.3.9

BPI-M2 Ultra IR interface	1.3.10
BPI-M2 Ultra HDMI interface	1.3.11
BPI-M2 Ultra USB interface	1.3.12
BPI-M2 Ultra OTG interface	1.3.13
BPI-M2 Ultra bluetooth interface	1.3.14
BPI-M2 Ultra UART port	1.3.15
BPI-M2 Ultra MIPI DSI interface	1.3.16
BPI-M2 Ultra CSI camera interface	1.3.17
BPI-M2 Ultra 3.7V lithium battery interface	1.3.18
BPI-M2 Ultra Power interface	1.3.19
BPI-M2 Ultra schematic diagram	1.3.20
BPI-M2 Ultra DXF and 3D design	1.3.21
BPI-M2 Ultra/Berry software	1.4
Android image	1.4.1
Linux software image	1.4.2
Tina-IoT os	1.4.3
BPI-tools	1.4.4
bpi-bootsel command	1.4.4.1
bpi-get command	1.4.4.2
bpi-copy command	1.4.4.3
bpi-update	1.4.4.4
WiringPi for BPI-M2 Ultra	1.4.5
BPI-M2 Ultra /Berry source code on github	1.5
BPI-Berry/BPI-Ultra How to alter Uboot \ Kernel from github	1.5.1
how to boot from emmc with SD data	1.5.2
How to rebuild bootloader BPI_M2U_720P-emmc.img.gz	1.5.3
BPI-M2 Ultra/Berry TinaLinux github	1.5.4
Reference documents	1.6
Allwinner R40/V40 chip datasheet	1.6.1
linux-sunxi document	1.6.2
BPI-M2 Ultra quality guarantee	1.7
BPI-M2 Ultra WIFI & BT4.0 Lab test	1.7.1
BPI-M2 Ultra validation test report	1.7.2
BPI-M2 Ultra CE, FCC RoHS Certification	1.7.3

BPI-M2 Berry CE,FCC RoHS Certification	1.7.4
All Banana Pi SBC Comparison	1.8
All banana pi product	1.9

About banana pi BPI-M2 Ultra



Banana Pi BPI-M2 Ultra is the open source hardware platform, Banana Pi BPI-M2 Ultra is a quad-core cortex -A7 CPU ,use Allwinner R40 design, it support WIFI+BT on board.and support SATA interface on board.

Banana Pi BPI-M2 Ultra series run Android, Debian linux, Ubuntu linux,Raspbian system and other OS.

Banana Pi PBI-M2 Ultra hardware: Quad Core ARM Cortex A7,ARMv7 CPU, 2GB DDR3 SDRAM, 8G eMMC flash on board

Banana Pi BPI-M2 Ultra with Gigabit Ethernet port, It can run Android smoothly. The size of Banana Pi BPI-M2 Ultra same as Banana Pi BPI-M64, support 1080P video, the 40 pin GPIO header is pin-compatible with Raspberry Pi.

The new BPI-M2 Ultra is a tiny little computer with great big ambitions. The expandable single-board device runs either Linux or Android and features impressive specs that outshine comparable products by a substantial margin. Highlights include a quad-core ARMv7 processor, a Mali 400 MP2 GPU, 2G of DDR3 RAM, a microSDXC slot,8G eMMC flash,WIFI&BT onboard and support for 1080P ultra high-definition video.

More specs follow below.

- Quad Core ARM Cortex A7 CPU
- Dual core Mali 400 MP2 GPU
- 2G DDR3 SDRAM
- **support SATA interface**
- MicroSD slot supports up to 256GB expansion
- 8G eMMC flash (option 16/32/64G)
- CSI camera interface and DSI display interface support
- 10/100/1000 Mb Ethernet port
- (3) USB 2.0 hosts and (1) USB otg port
- 1080P high-definition video playback
- HDMI port and multi-channel audio output
- WIFI&Bluetooth 4.0 with 802.11BGN onboard
- 3.5mm Stereo Output mini-jack with microphone support
- Built-in 3.7V Lithium Battery Charging Circuit
- Hardware security enables trustzone security system, Digital Rights Management (DRM), information encryption/decryption, secure boot, secure JTAG and secure efuse

About banana pi BPI-M2 Berry



Banana PI BPI-M2 Berry is the open source hardware platform, Banana PI BPI-M2 Berry is a quad-core cortex -A7 CPU ,use Allwinner R40 design, it support WIFI+BT on board.and support SATA interface on board.

Banana Pi BPI-M2 Berry series run Android, Debian linux, Ubuntu linux,Raspbian system and other OS.

Banana PI PBI-M2 Berry hardware: Quad Core ARM Cortex A7,ARMv7 CPU, 2GB DDR3 SDRAM, all size is same as raspberry pi 3. note ,BPI-M2 Berry not onboard eMMC flash support.

Banana PI BPI-M2 Berry with Gigabit Ethernet port, It can run Android smoothly. The size of Banana PI BPI-M2 Berry same as Banana Pi BPI-M64, support 1080P video, the 40 pin GPIO header is pin-compatible with Raspberry Pi.

The new BPI-M2 Berry is a tiny little computer with great big ambitions. The expandable single-board device runs either Linux or Android and features impressive specs that outshine comparable products by a substantial margin. Highlights include a quad-core ARMv7 processor, a Mali 400 MP2 GPU, and support for 1080P ultra high-definition video.

More specs follow below.

- Quad Core ARM Cortex A7 CPU
- Dual core Mali 400 MP2 GPU
- 1G DDR3 SDRAM
- **support SATA interface**
- MicroSD slot supports up to 256GB expansion
- **Not 8G eMMC flash onboard**
- CSI camera intface and DSI display interface support
- 10/100/1000 Mb Ethernet port
- (4) USB 2.0 hosts and (1) USB otg port
- 1080P high-definition video playback
- HDMI port and multi-channel audio output
- WIFI&Bluetooth 4.0 with 802.11BGN onboard
- 3.5mm Stereo Output mini-jack with microphone support
- **Not support Built-in 3.7V Lithium Battery Charging Circuit**
- Hardware security enables trustzone security system, Digital Rights Management (DRM), information encryption/decryption, secure boot, secure JTAG and secure efuse

BPI-M2 Berry is same size as raspberry pi 3 , so you can use raspberry pi box .

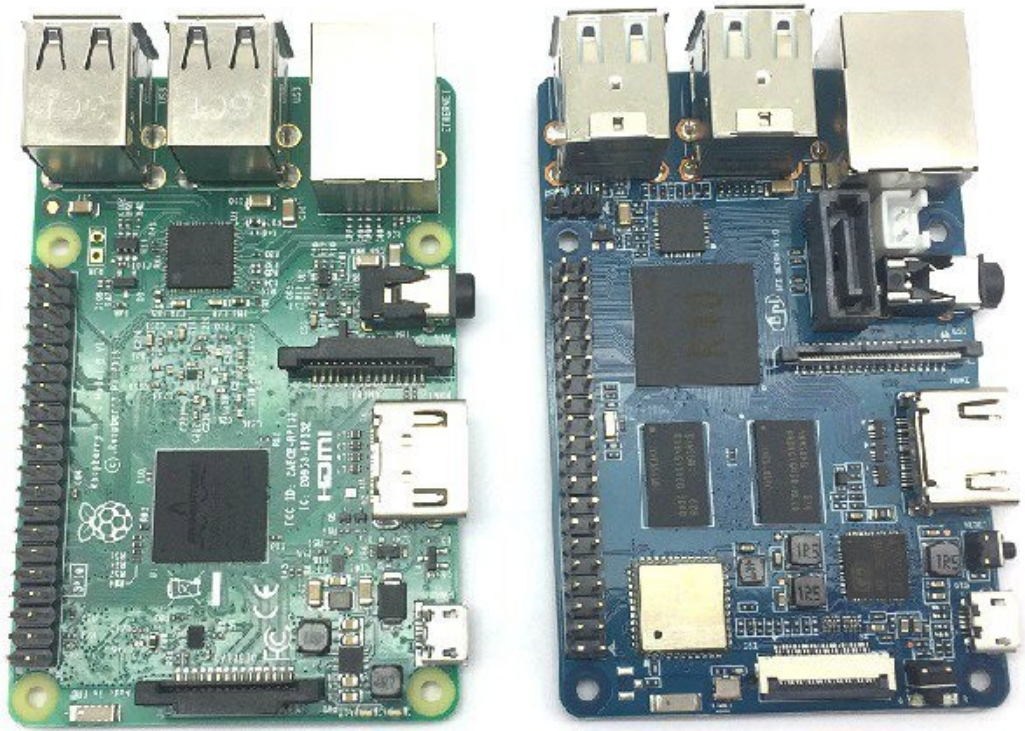

BPI-M2 Berry with raspberry pi boxes. for BPI-M2 Berry have sata interface ,just note space for this .



allwinner R40 chip and V40 chip is PIN to PIN compatibility, so BPI-M2 Ultra just replace V40 chip onboard, easy to DIY and do a new product

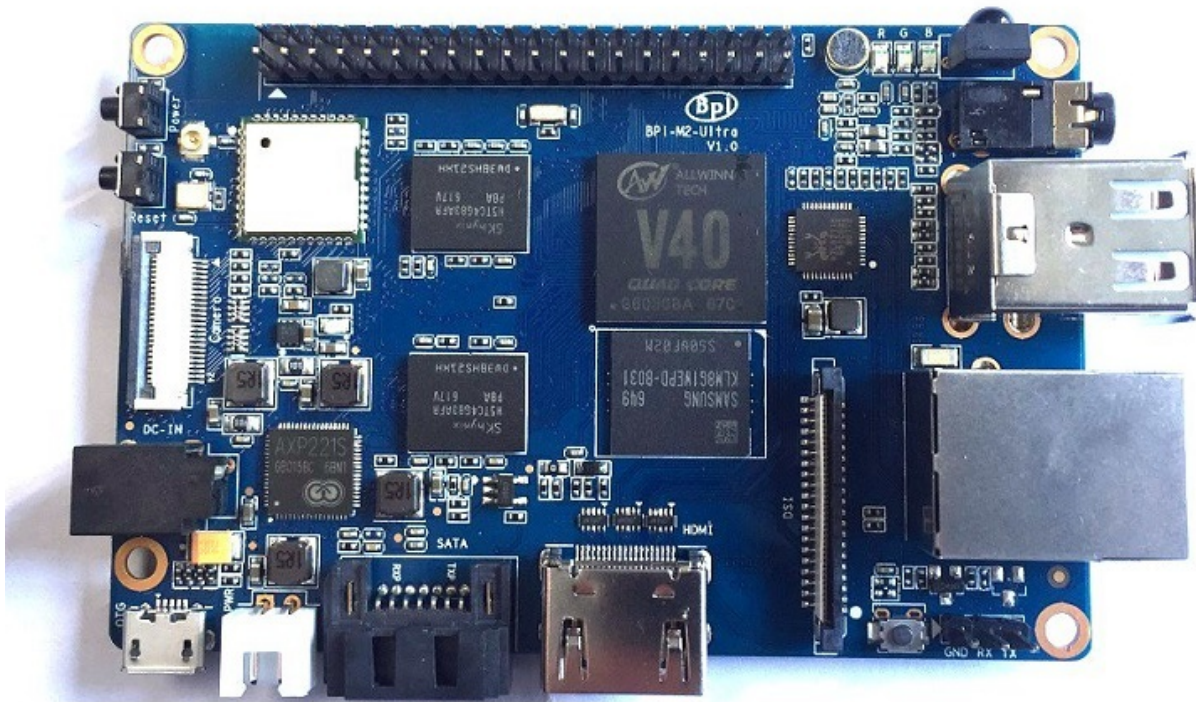

forum: <http://www.banana-pi.org>

forum: <http://www.bananapi.com>

product: <http://www.banana-pi.com>

easy to buy a sample :



BPI-M2 Berry hardware interface:

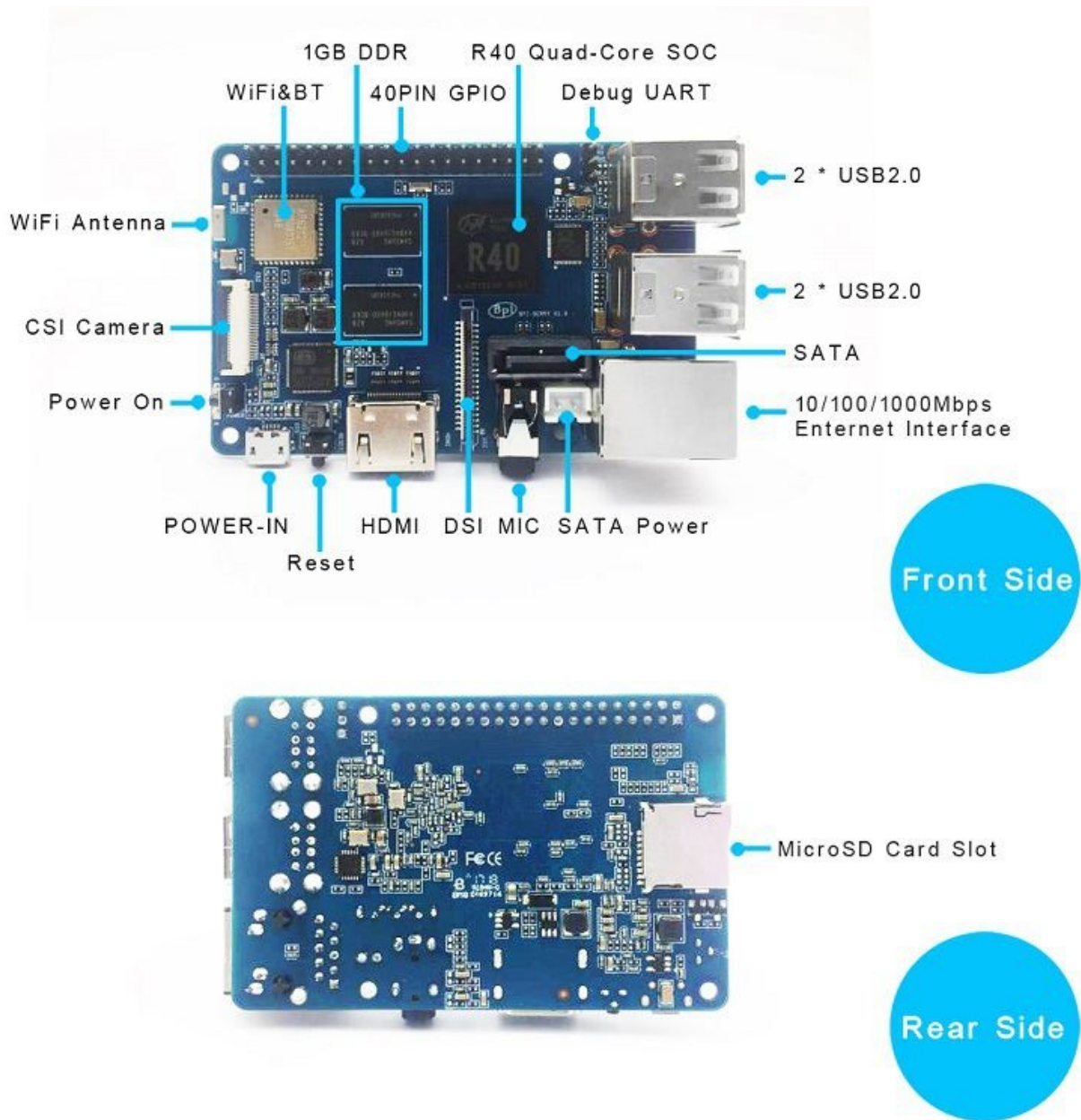

BPI-M2 Ultra hardware spec

Hardware Specification of Banana pi BPI-M2 Berry

Soc	Allwinner R40/V40
CPU	quad-core cortex -A7,the most power efficient CPU core ARM's ever development
GPU	dual-core MALI-400 MP2 and runs at 500MHz, capable of 1.1 Gpixel/s throughput. Graphics capabilities are slightly higher than the original Xbox's level of performance. The GPU provides OpenGL ES 2.0, hardware-accelerated OpenVG, 1080p45 H.264 high-profile encode and decode.
SDRAM	1GB DDR3 with 733MHz(shared with GPU)
SATA	support SATA interface
GPIO	40 Pins Header, 28×GPIO, some of which can be used for specific functions including UART, I2C, SPI, PWM, I2S.
On board Network	10/100/1000Mbps Ethernet (Realtek RTL8211E/D)
Wifi Module	WiFi 802.11 b/g/n (AP 6212 module on board)
Bluetooth	BT4.0
On board Storage	MicroSD (TF) card, No eMMC onboard
Display	4-lane MIPI DSI display,or RGB panel or LVDS panel,TV-out on HDMI V1.4
Video	Multi-format FHD video decoding, including Mpeg1/2, Mpeg4, H.263, H.264, etc H.264 decode up to 1080P60,support video encoding:High-deinition(HD)H.264 video encoder is up to 1080P@45fps
Audio outputs	HDMI, analog audio (via 3.5 mm TRRS jack), I2S audio (also potentially for audio input)
Camera	A CSI input connector Camera:Supports 8-bit YUV422 CMOS sensor interface,Supports CCIR656 protocol for NTSC and PAL,Supports 5M pixel camera sensor ,Supports video capture solution up to 1080p@30fps
Audio input	On board microphone
USB	4 USB 2.0 host, 1 USB 2.0 OTG
Buttons	Reset button, Power button, U-boot button
Leds	Power status Led and RJ45 Led

IR	No onboard IR receiver
DC Power	5V/2A with micro USB port
battery	No 3.7V lithium battery power support
Sizes	85mmX56mm,same size as raspberry pi 3
Weight	40g

BPI-M2 Berry GPIO Pin define,all define same as BPI-M2 Ultra

BPI-M2 Berry have 40 PIN GPIO as raspberry pi.

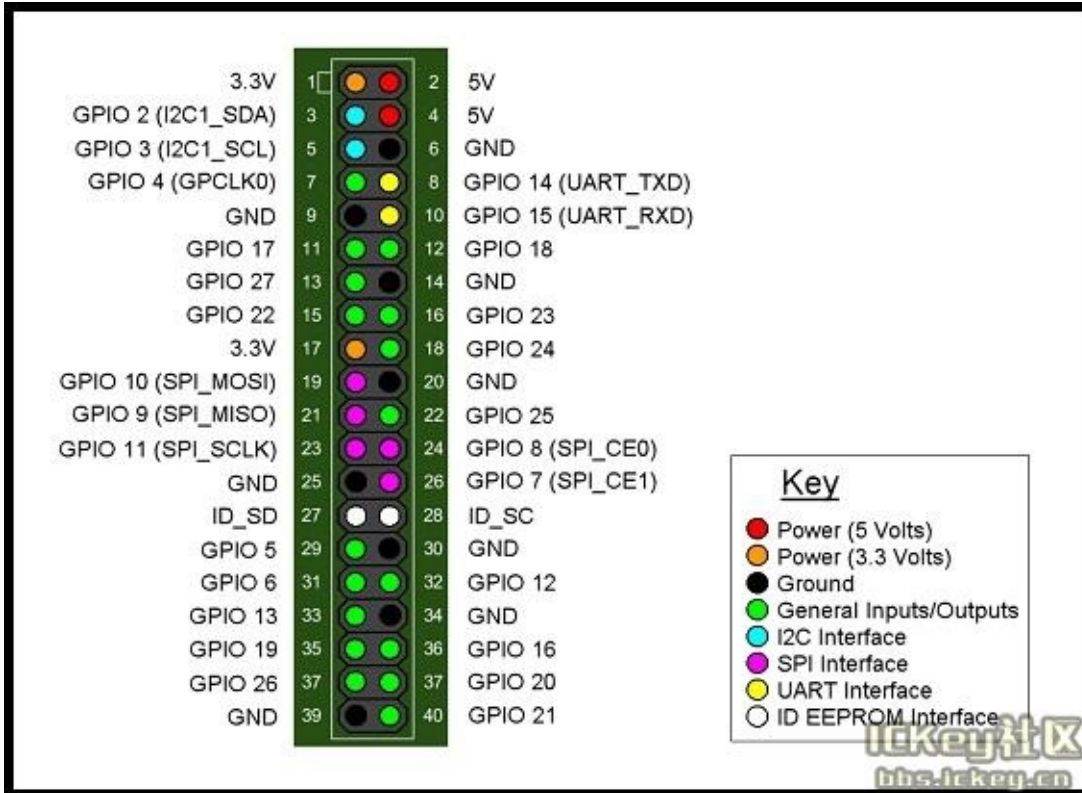

Banana Pi has a 40-pin GPIO header that matches that of the Model B+ Raspberry Pi.

Following is the Banana Pi GPIO Pinout:

	GPIO Pin Name	Default Function	Function2 : GPIO	Function3
		CON1-P01	VCC-3V3	
		CON1-P02	DCIN	
	CON1-P03	TWI2-SDA	PB21	PWM5
		CON1-P04	DCIN	
	CON1-P05	TWI2-SCK	PB20	PWM4
		CON1-P06	GND	
	CON1-P07	PB3	PB3	PWM1
	CON1-P08	UART2-TX	PI18	SPI1_MOSI
		CON1-P09	GND	

	CON1-P10	UART2-RX	PI19	SPI1_MISO
	CON1-P11	UART7-TX	PI20	PWM2
	CON1-P12	UART2-CTS	PI17	SPI1_CLK
	CON1-P13	UART7-RX	PI21	PWM3
		CON1-P14	GND	
	CON1-P15	PH25	PH25	CSI1-FIELD
	CON1-P16	UART2-RTS	PI16	SPI1_CS0
		CON1-P17	VCC-3V3	
	CON1-P18	PH26	PH26	CSI1-HSYNC
	CON1-P19	SPI0_MOSI	PC0	
		CON1-P20	GND	
	CON1-P21	SPI0_MISO	PC1	
	CON1-P22	PH27	PH27	CSI1-VSYNC
	CON1-P23	SPI0_CLK	PC2	
	CON1-P24	SPI0_CS	PC23	
		CON1-P25	GND	
	CON1-P26	PH24	PH24	CSI1-PCLK
	CON1-P27	TWI3-SDA	PI1	
	CON1-P28	TWI3-SCK	PI0	
	CON1-P29	PH0	PH0	CSI1-D0
		CON1-P30	GND	
	CON1-P31	PH1	PH1	CSI1-D1
	CON1-P32	PD20	PD20	CSI1-MCLK
	CON1-P33	PH2	PH2	CSI1-D2
		CON1-P34	GND	
	CON1-P35	PH3	PH3	CSI1-D3
	CON1-P36	UART5-RX	PH7	CSI1-D7
	CON1-P37	UART4-TX	PH4	CSI1-D4
	CON1-P38	UART5-TX	PH6	CSI1-D6
		CON1-P39	GND	

CON1-P40	UART4-RX	PH5	CSI1-D5
----------	----------	-----	---------

CSI Camera Connector specification:

The CSI Camera Connector is a 24-pin FPC connector which can connect external camera module with proper signal pin mappings. The pin definitions of the CSI interface are shown as below. This is marked on the Banana Pi board as “Camera”.

CSI Pin Name	Default Function	Function2 : GPIO
CN5-P01	NC	
CN5-P02	GND	
CN5-P03	CSI0-SDA	PI3
	CN5-P04	CSI0-AVDD
CN5-P05	CSI0-SCK	PI2
CN5-P06	CSI0-Reset	PI7
CN5-P07	CSI0-VSYNC	PE3
CN5-P08	CSI0-PWDN	PI6
CN5-P09	CSI0-HSYNC	PE2
	CN5-P10	CSI0-DVDD
	CN5-P11	CSI0-DOVDD
CN5-P12	CSI0-D7	PE11
CN5-P13	CSI0-MCLK	PE1
CN5-P14	CSI0-D6	PE10
	CN5-P15	GND
CN5-P16	CSI0-D5	PE9
CN5-P17	CSI0-PCLK	PE0
CN5-P18	CSI0-D4	PE8
CN5-P19	CSI0-D0	PE4
CN5-P20	CSI0-D3	PE7
CN5-P21	CSI0-D1	PE5
CN5-P22	CSI0-D2	PE6
CN5-P23	GND	
	CN5-P24	CSI0-AFVCC

Display specification

MIPI DSI (Display Serial Interface)

The display Connector is a 40-pin FPC connector which can connect external LCD panel (MIPI DSI) and touch screen (I2C) module as well. The pin definitions of this connector are shown as below. This is marked on the Banana Pi board as “DSI”.

	DSI Pin Name	Default Function	Function2 : GPIO
		CN6-P01	VCC-3V3
		CN6-P02	IPSOUT
		CN6-P03	VCC-3V3
	CN6-P04	IPSOUT	
		CN6-P05	GND
		CN6-P06	IPSOUT
		CN6-P07	GND
		CN6-P08	IPSOUT
		CN6-P09	NC
		CN6-P10	GND
		CN6-P11	NC
		CN6-P12	DSI-D0N
		CN6-P13	NC
		CN6-P14	DSI-D0P
		CN6-P15	NC
		CN6-P16	GND
	CN6-P17	TWI0-SDA	PB19
		CN6-P18	DSI-D1N
	CN6-P19	TWI0-SCK	PB18
		CN6-P20	DSI-D1P
	CN6-P21	CTP-INT	PI10
	CN6-P22	GND	
	CN6-P23	CTP-RST	PI11
	CN6-P24	DSI-CKN	
		CN6-P25	GND

		CN6-P26	DSI-CKP
	CN6-P27	LCD-BL-EN	PH16
		CN6-P28	GND
	CN6-P29	LCD-RST	PH17
		CN6-P30	DSI-D2N
	CN6-P31	LCD-PWR-EN	PH18
		CN6-P32	DSI-D2P
		CN6-P33	GND
		CN6-P34	GND
	CN6-P35	LCD-PWM	PB2
		CN6-P36	DSI-D3N
		CN6-P37	GND
		CN6-P38	DSI-D3P
		CN6-P39	NC
CN6-P40	GND		

UART specification:

The header CON4 is the UART interface. For developers of Banana Pi, this is an easy way to get the UART console output to check the system status and log message.

	CON2 Pin Name	Default Function	GPIO
	CON2 P03	UART0-TXD	
	CON2 P02	UART0-RXD	
CON2 P01	GND		

BPI-M2 Berry SATA interface

BPI-M2 Berry support sata interface and onboard power port.

you can use sata line connect your hardisk on BPI-M2 Berry.

Note:

if you use 3.5 big hardisk ,you may need power with outside power. on board power can not support enough current

BPI-M2 Berry micro SD card slot

BPI-M2 Berry have support a TF card slot. you can burn image to TF card ,and use it boot BPI-M2 Berry same as raspberry pi.



Note:

- support 8G 16G 32G 64G
- please choose class 10 TF card for banana pi.

BPI-M2 Berry GigE LAN

Banana PI BPI-M2 Berry with one Gigabit ethernet port,use RTL8211E chip on board.

BPI-M2 Berry WIFI interface

BPI-M2 Berry support AP6212 wifi module on board.used. it support 802.11/b/g/n wifi.

test report ,please see: BPI-M2 Berry wifi Lab test

about AP6212 wifi&BT module spec:

http://wiki.friendlyarm.com/wiki/images/5/57/AP6212_V1.1_09022014.pdf

BPI-M2 Berry wifi antenna slot

banana pi BPI-M2 Berry have support ap6212 wifi&BT module onboard

BPI-M2 Berry have wifi antenna slot on board

wifi extend antenna slot spec:

RECOMMENDED PCB LAYOUT

NOTE: UNLESS OTHERWISE SPECIFIED
 1. DIMENSION SHALL BE INTERPRETED PER ANSI Y14.5M-1994.
 2. DIMENSION MARKED WITH "▼" SHOULD SPECIFIED ON INSPECTION PLAN.
 3. CONTACT RETENTION FORCE: 0.4 N MIN.
 4. CONTACT MATERIAL: COPPER ALLOY.
 5. INSULATOR: HIGH TEMPERATURE PLASTIC UL94 V-0.
 6. CONTACT FINISH: GOLD PLATED 5μ" ON MATING AREAR, GOLD FINISH 1μ" ON SHELL, ALL OVER 50μ" NICKEL UNDER PLATED.
 7. ALL MATERIAL MEET RoHS SPECIFICATION AND IN CONFORMITY WITH REACH & SVHC STANDARD STIPULATIONS.

3	GROUND PAD	METAL SHELL, GOLD/BRIGHT GOLD PLATING	1
2	CENTER PIN	CENTER CNT, GOLD/BRIGHT GOLD PLATING	1
1	HOUSING	OVER MOLD HOUSING, LCP, IVORY, UL94V-0	1
ITEM	PART NUMBER	DESCRIPTION	Q'TY

TOLERANCES			
X ±0.50	XX ±0.15		
X ±0.25	XXX ±0.10		
ANGLES: 8.2°			
TITLE		RF RECEPTACLE(U.FL)	
DWG NO.		635004802	
FINISH		SCALE	1:1
		UNITS	mm
DRW	109/09/17	ERIC	
CHECK		MICHAEL	
APPD		MICHAEL	
SHEET	1 OF 1	A#	0

so you can use 3DB/5DB wifi antenna on BPI-M2 Berry

BPI-M2 Berry HDMI interfact

BPI-M2 Berry has a standard HDMI 1.4 interface. so We can use HDMI-to-HDMI cable to connect BPI-M2 Berry to the display monitor that has HDMI interface.



But If the display monitor doesn't have HDMI interface,only VGA or DVI port. We should use HDMI-to-VGA or HDMI-to-DVI cable to connect the BPI-M2 Berry to the display monitor.



Note: if the HDMI-to-VGA/DVI cable is a bad quality cable,it will go wrong on the monitor display. please choose a good quality cable for BPI-M2 Berry

BPI-M2 Berry USB interface

BPI-M2 Ultra have 4 USB 2.0 interface on board.so you can connect Keyboard,mouse, USB camera and ... on BPI-M2 Berry

BPI-M2 Berry OTG interface

banana pi BPI-M2 Berry have 1 OTG port on board.

BPI-M2 Berry bluetooth interface

BPI-M2 Berry have AP6212 WiFi&Bluetooth on board. it support bluetooth function by defaults.

BPI-M2 Berry UART port

UART specification:

The header CON4 is the UART interface. For developers of Banana Pi, this is an easy way to get the UART console output to check the system status and log message.

	CON2 Pin Name	Default Function	GPIO
	CON2 P03	UART0-TXD	
	CON2 P02	UART0-RXD	
CON2 P01	GND		

BPI-M2 Berry MIPI DSI interface

MIPI DSI (Display Serial Interface) :

The display Connector is a 40-pin FPC connector which can connect external LCD panel (MIPI DSI) and touch screen (I2C) module as well. The pin definitions of this connector are shown as below. This is marked on the Banana Pi board as “DSI”.

DSI pin define:

please see: BPI-M2 Berry GPIO pine define

BPI-M2 Berry LCD touch panel accessories same as BPI-M3

<https://bananapi.gitbooks.io/bpi-accessories/content/bpi70lcdtouchpanel.html>

- note:the touch panel accessories support RGB interface and MIPI interface ,when you use BPI-M2 Ultra, please choose MIPI interface.

BPI-M2 Berry CSI camera interface

BPI-M2 Ultra/Berry support OV5640 Camera with official accesories.

all image have include this driver.

you also can reference this :

[BPI-M2 Berry CSI camera Camera\(OV5640\)](#)

[BPI-M2 Berry mjpg-streamer](#)

BPI-M2 Berry Power interface

BPI-M2 Berry power with Micro USB port (default) .

Note: please choose 5V/2A adapter to power on it.

Banana pi BPI-M2 Berry DXF

<https://drive.google.com/file/d/0B4PAo2nW2Kfnci1xaHd5eWtseEU/view?usp=sharing>

Banana pi BPI-M2 Berry Schematic :



google download link:

<https://drive.google.com/file/d/0B4PAo2nW2KfnTEMtNXpJWEJDTmc/view?usp=sharing>

BPI-M2 Ultra hardware



BPI-M2 Ultra hardware interface

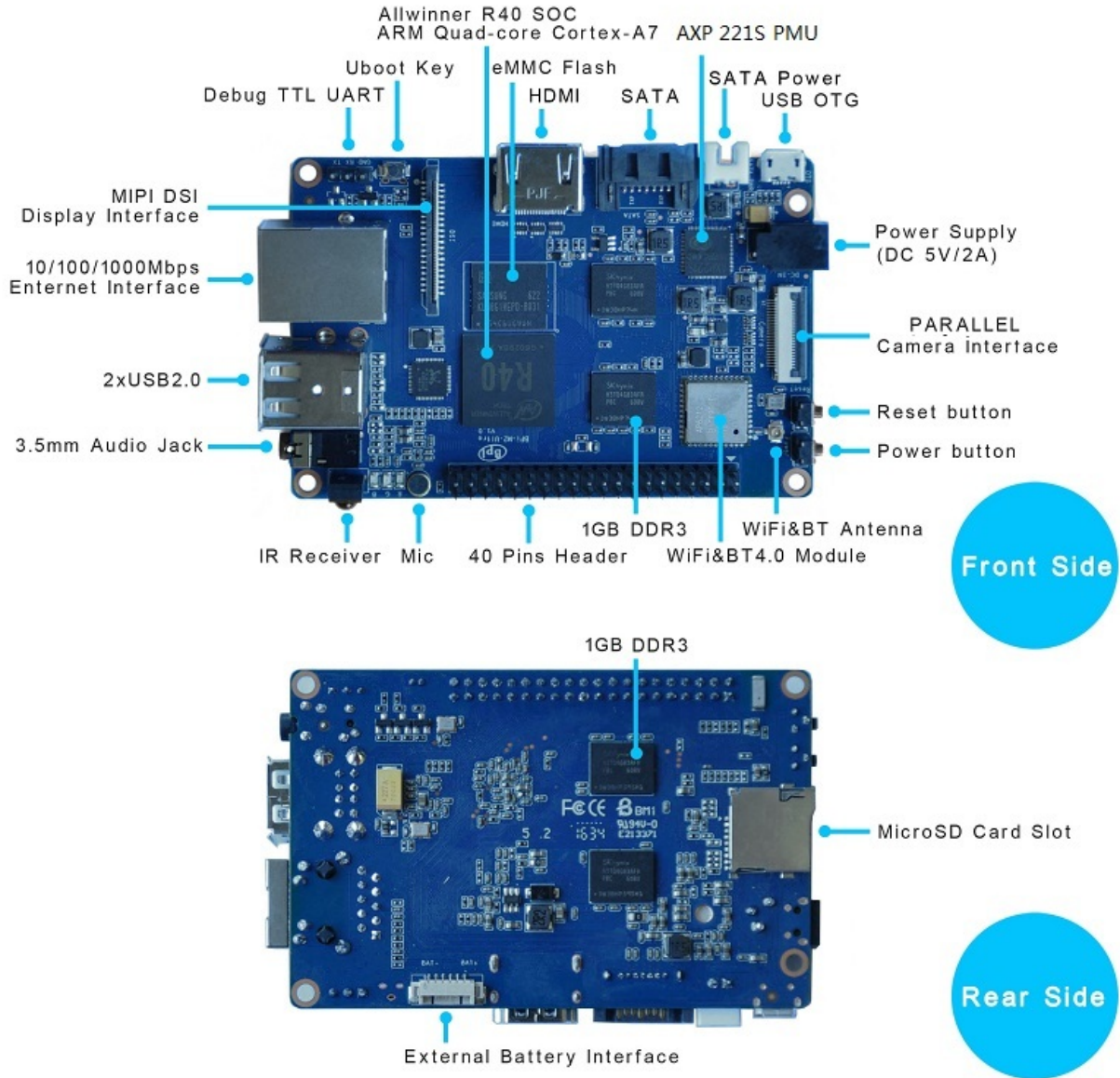

BPI-M2 Ultra hardware spec

Hardware Specification of Banana pi BPI-M2 Ultra

Soc	Allwinner R40
CPU	quad-core cortex -A7, the most power efficient CPU core ARM's ever development
GPU	dual-core MALI-400 MP2 and runs at 500MHz, capable of 1.1 Gpixel/s throughput. Graphics capabilities are slightly higher than the original Xbox's level of performance. The GPU provides OpenGL ES 2.0, hardware-accelerated OpenVG, 1080p45 H.264 high-profile encode and decode.
SDRAM	2GB DDR3 with 733MHz(shared with GPU)
SATA	support SATA interface
GPIO	40 Pins Header, 28×GPIO, some of which can be used for specific functions including UART, I2C, SPI, PWM, I2S.
On board Network	10/100/1000Mbps Ethernet (Realtek RTL8211E/D)
Wifi Module	WiFi 802.11 b/g/n (AP 6212 module on board)
Bluetooth	BT4.0
On board Storage	MicroSD (TF) card, eMMC 8G on board (option : 16/32/64G)
Display	4-lane MIPI DSI display, or RGB panel or LVDS panel, TV-out on HDMI V1.4
Video	Multi-format FHD video decoding, including Mpeg1/2, Mpeg4, H.263, H.264, etc H.264 decode up to 1080P60, support video encoding: High-definition(HD)H.264 video encoder is up to 1080P@45fps
Audio outputs	HDMI, analog audio (via 3.5 mm TRRS jack), I2S audio (also potentially for audio input)
Camera	A CSI input connector Camera: Supports 8-bit YUV422 CMOS sensor interface, Supports CCIR656 protocol for NTSC and PAL, Supports 5M pixel camera sensor, Supports video capture solution up to 1080p@30fps
Audio input	On board microphone
USB	3 USB 2.0 host, 1 USB 2.0 OTG
Buttons	Reset button, Power button, U-boot button
Leds	Power status Led and RJ45 Led

IR	on board IR receiver
DC Power	5V/2A with DC port
battery	3.7V lithium battery power support
Sizes	92mm×60mm
Weight	45g

BPI-M2 Ultra GPIO Pin define

BPI-M2 Ultra have 40 PIN GPIO as raspberry pi.

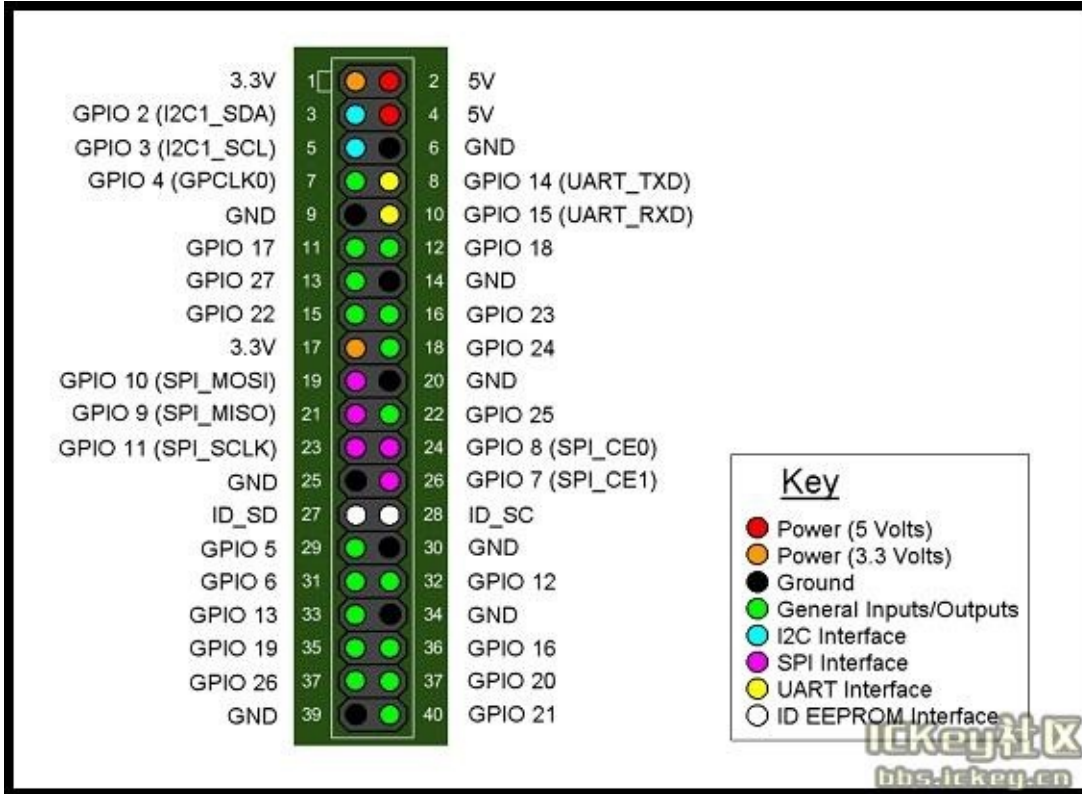

Banana Pi has a 40-pin GPIO header that matches that of the Model B+ Raspberry Pi. Following is the Banana Pi GPIO Pinout:

	GPIO Pin Name	Default Function	Function2 : GPIO	Function3
		CON1-P01	VCC-3V3	
		CON1-P02	DCIN	
	CON1-P03	TWI2-SDA	PB21	PWM5
		CON1-P04	DCIN	
	CON1-P05	TWI2-SCK	PB20	PWM4
		CON1-P06	GND	
	CON1-P07	PB3	PB3	PWM1
	CON1-P08	UART2-TX	PI18	SPI1_MOSI
		CON1-P09	GND	
	CON1-P10	UART2-RX	PI19	SPI1_MISO

	CON1-P11	UART7-TX	PI20	PWM2
	CON1-P12	UART2-CTS	PI17	SPI1_CLK
	CON1-P13	UART7-RX	PI21	PWM3
		CON1-P14	GND	
	CON1-P15	PH25	PH25	CSI1-FIELD
	CON1-P16	UART2-RTS	PI16	SPI1_CS0
		CON1-P17	VCC-3V3	
	CON1-P18	PH26	PH26	CSI1-HSYNC
	CON1-P19	SPI0_MOSI	PC0	
		CON1-P20	GND	
	CON1-P21	SPI0_MISO	PC1	
	CON1-P22	PH27	PH27	CSI1-VSYNC
	CON1-P23	SPI0_CLK	PC2	
	CON1-P24	SPI0_CS	PC23	
		CON1-P25	GND	
	CON1-P26	PH24	PH24	CSI1-PCLK
	CON1-P27	TWI3-SDA	PI1	
	CON1-P28	TWI3-SCK	PI0	
	CON1-P29	PH0	PH0	CSI1-D0
		CON1-P30	GND	
	CON1-P31	PH1	PH1	CSI1-D1
	CON1-P32	PD20	PD20	CSI1-MCLK
	CON1-P33	PH2	PH2	CSI1-D2
		CON1-P34	GND	
	CON1-P35	PH3	PH3	CSI1-D3
	CON1-P36	UART5-RX	PH7	CSI1-D7
	CON1-P37	UART4-TX	PH4	CSI1-D4
	CON1-P38	UART5-TX	PH6	CSI1-D6
		CON1-P39	GND	
CON1-P40	UART4-RX	PH5	CSI1-D5	

CSI Camera Connector specification:

The CSI Camera Connector is a 24-pin FPC connector which can connect external camera module with proper signal pin mappings. The pin definitions of the CSI interface are shown as below. This is marked on the Banana Pi board as “Camera”.

CSI Pin Name	Default Function	Function2 : GPIO
CN5-P01	NC	
CN5-P02	GND	
CN5-P03	CSI0-SDA	PI3
	CN5-P04	CSI0-AVDD
CN5-P05	CSI0-SCK	PI2
CN5-P06	CSI0-Reset	PI7
CN5-P07	CSI0-VSYNC	PE3
CN5-P08	CSI0-PWDN	PI6
CN5-P09	CSI0-HSYNC	PE2
	CN5-P10	CSI0-DVDD
	CN5-P11	CSI0-DOVDD
CN5-P12	CSI0-D7	PE11
CN5-P13	CSI0-MCLK	PE1
CN5-P14	CSI0-D6	PE10
	CN5-P15	GND
CN5-P16	CSI0-D5	PE9
CN5-P17	CSI0-PCLK	PE0
CN5-P18	CSI0-D4	PE8
CN5-P19	CSI0-D0	PE4
CN5-P20	CSI0-D3	PE7
CN5-P21	CSI0-D1	PE5
CN5-P22	CSI0-D2	PE6
CN5-P23	GND	
	CN5-P24	CSI0-AFVCC

Display specification

MIPI DSI (Display Serial Interface)

The display Connector is a 40-pin FPC connector which can connect external LCD panel (MIPI DSI) and touch screen (I2C) module as well. The pin definitions of this connector are shown as below. This is marked on the Banana Pi board as “DSI”.

	DSI Pin Name	Default Function	Function2 : GPIO
		CN6-P01	VCC-3V3
		CN6-P02	IPSOUT
		CN6-P03	VCC-3V3
	CN6-P04	IPSOUT	
		CN6-P05	GND
		CN6-P06	IPSOUT
		CN6-P07	GND
		CN6-P08	IPSOUT
		CN6-P09	NC
		CN6-P10	GND
		CN6-P11	NC
		CN6-P12	DSI-D0N
		CN6-P13	NC
		CN6-P14	DSI-D0P
		CN6-P15	NC
		CN6-P16	GND
	CN6-P17	TWI0-SDA	PB19
		CN6-P18	DSI-D1N
	CN6-P19	TWI0-SCK	PB18
		CN6-P20	DSI-D1P
	CN6-P21	CTP-INT	PI10
	CN6-P22	GND	
	CN6-P23	CTP-RST	PI11
	CN6-P24	DSI-CKN	
		CN6-P25	GND
		CN6-P26	DSI-CKP
	CN6-P27	LCD-BL-EN	PH16
		CN6-P28	GND

	CN6-P29	LCD-RST	PH17
		CN6-P30	DSI-D2N
	CN6-P31	LCD-PWR-EN	PH18
		CN6-P32	DSI-D2P
		CN6-P33	GND
		CN6-P34	GND
	CN6-P35	LCD-PWM	PB2
		CN6-P36	DSI-D3N
		CN6-P37	GND
		CN6-P38	DSI-D3P
		CN6-P39	NC
CN6-P40	GND		

UART specification:

The header CON4 is the UART interface. For developers of Banana Pi, this is an easy way to get the UART console output to check the system status and log message.

	CON2 Pin Name	Default Function	GPIO
	CON2 P03	UART0-TXD	
	CON2 P02	UART0-RXD	
CON2 P01	GND		

BPI-M2 Ultra SATA interface

BPI-M2 Ultra support sata interface and onboard power port.

you can use sata line connect your hardisk on BPI-M2 Ultra.

Note:

if you use 3.5 big hardisk ,you may need power with outside power. on board power can not support enough current

BPI-M2 Ultra micro SD card slot

BPI-M2 Ultra have support a TF card slot. you can burn image to TF card ,and use it boot BPI-M2 Ultra same as raspberry pi.



Note:

- support 8G 16G 32G 64G
- please choose class 10 TF card for banana pi.

BPI-M2 Ultra GigE LAN

Banana PI BPI-M2 Ultra with one Gigabit ethernet port,use RTL8211E chip on board.

BPI-M2 Ultra eMMC flash

BPI-M2 Ultra have support 8G eMMC flash on board by defaults.for customization user , we can add 4-64G emmc on board.

So, you can burn your image to eMMC flash and boot from eMMC flash.

How to burn Android image to eMMC

please read this book :

2.2.1 How to burn android image to eMMC

How to burn Linux image to eMMC

please read this book:

2.3.1 How to burn linux image to eMMC

Note:

the first boot is from microSD card. if you want to boot from eMMC flash ,please remove microSD card from BPI-M2 Ultra microSD card slots.

BPI-M2 Ultra WIFI interface

BPI-M2 Ultra support AP6212 wifi module on board.used. it support 802.11/b/g/n wifi.

test report ,please see: BPI-M2 Ultra wifi Lab test

about AP6212 wifi&BT module spec:

http://wiki.friendlyarm.com/wiki/images/5/57/AP6212_V1.1_09022014.pdf

BPI-M2 Ultra wifi antenna slot

banana pi BPI-M2 Ultra have support ap6212 wifi&BT module onboard

BPI-M2 Ultra have wifi antenna slot on board

wifi extend antenna slot spec:

RECOMMENDED PCB LAYOUT

NOTE: UNLESS OTHERWISE SPECIFIED
 1. DIMENSION SHALL BE INTERPRETED PER ANSI Y14.5M-1994.
 2. DIMENSION MARKED WITH "▼" SHOULD SPECIFIED ON INSPECTION PLAN.
 3. CONTACT RETENTION FORCE: 0.4 N MIN.
 4. CONTACT MATERIAL: COPPER ALLOY.
 5. INSULATOR: HIGH TEMPERATURE PLASTIC UL94 V-0.
 6. CONTACT FINISH: GOLD PLATED 5u" ON MATING AREAR, GOLD FINISH 1u" ON SHELL, ALL OVER 50u" NICKEL UNDER PLATED.
 7. ALL MATERIAL MEET RoHS SPECIFICATION AND IN CONFORMITY WITH REACH & SVHC STANDARD STIPULATIONS.

ITEM	PART NUMBER	DESCRIPTION	Q'TY
3	GROUND PAD	METAL SHELL, GOLD/BRIGHT GOLD PLATING	1
2	CENTER PIN	CENTER CNT, GOLD/BRIGHT GOLD PLATING	1
1	HOUSING	OVER MOLD HOUSING, LCP, IVORY, UL94V-0	1

TOLERANCES		DWN 108/08/17		ERIC
X ±0.50	XX ±0.15	TITLE		RF RECEPTACLE(U.FL)
X ±0.25	XXX ±0.10	CHECK		MICHAEL
ANGLES: 8.2°		DWG NO.		635004802
FINISH		SCALE		1:1
UNITS		mm		
SHEET		1 OF 1		A# 0

so you can use 3DB/5DB wifi antenna on BPI-M2 Ultra

BPI-M2 Ultra IR interface

BPI-M2 Ultra support IR interface on board. you can use it as remote control.

BPI-M2 Ultra HDMI interfact

BPI-M2 Ultra has a standard HDMI 1.4 interface. so We can use HDMI-to-HDMI cable to connect BPI-M2 Ultra to the display monitor that has HDMI interface.



But If the display monitor doesn't have HDMI interface,only VGA or DVI port. We should use HDMI-to-VGA or HDMI-to-DVI cable to connect the BPI-M2 Ultra to the display monitor.



Note: if the HDMI-to-VGA/DVI cable is a bad quality cable,it will go wrong on the monitor display. please choose a good quality cable for BPI-M2 Ultra

BPI-M2 Ultra USB interface

BPI-M2 Ultra have two USB 2.0 interface on board.so you can connect Keyboard,mouse, USB camera and ... on BPI-M2 Ultra

BPI-M2 Ultra OTG interface

banana pi BPI-M2 Ultra have 1 OTG port on board.

BPI-M2 Ultra bluetooth interface

BPI-M2 Ultra have AP6212 WiFi&Bluetooth on board. it support bluetooth function by defaults.

BPI-M2 Ultra UART port

UART specification:

The header CON4 is the UART interface. For developers of Banana Pi, this is an easy way to get the UART console output to check the system status and log message.

CON2 Pin Name	Default Function	GPIO
CON2 P03	UART0-TXD	
CON2 P02	UART0-RXD	
CON2 P01	GND	

BPI-M2 Ultra MIPI DSI interface

MIPI DSI (Display Serial Interface) :

The display Connector is a 40-pin FPC connector which can connect external LCD panel (MIPI DSI) and touch screen (I2C) module as well. The pin definitions of this connector are shown as below. This is marked on the Banana Pi board as “DSI”.

DSI pin define:

please see: BPI-M2 Ultra GPIO pine define

Banana pi BPI M2 Ultra LCD how to

<https://www.youtube.com/watch?v=-6vtL3couxo>

BPI-M2 Ultra LCD touch panel accessories same as BPI-M3

<https://bananapi.gitbooks.io/bpi-accessories/content/bpi70lcdtouchpanel.html>

- note:the touch panel accessories support RGB interface and MIPI interface ,when you use BPI-M2 Ultra, please choose MIPI interface.

BPI-M2 Ultra CSI camera interface

BPI-M2 Ultra/Berry support OV5640 Camera with official accesories.

all image have include this driver.

you also can reference this :

[BPI-M2 Berry CSI camera Camera\(OV5640\)](#)

[BPI-M2 Berry mjpg-streamer](#)

BPI-M2 Ultra 3.7V lithium battery interface

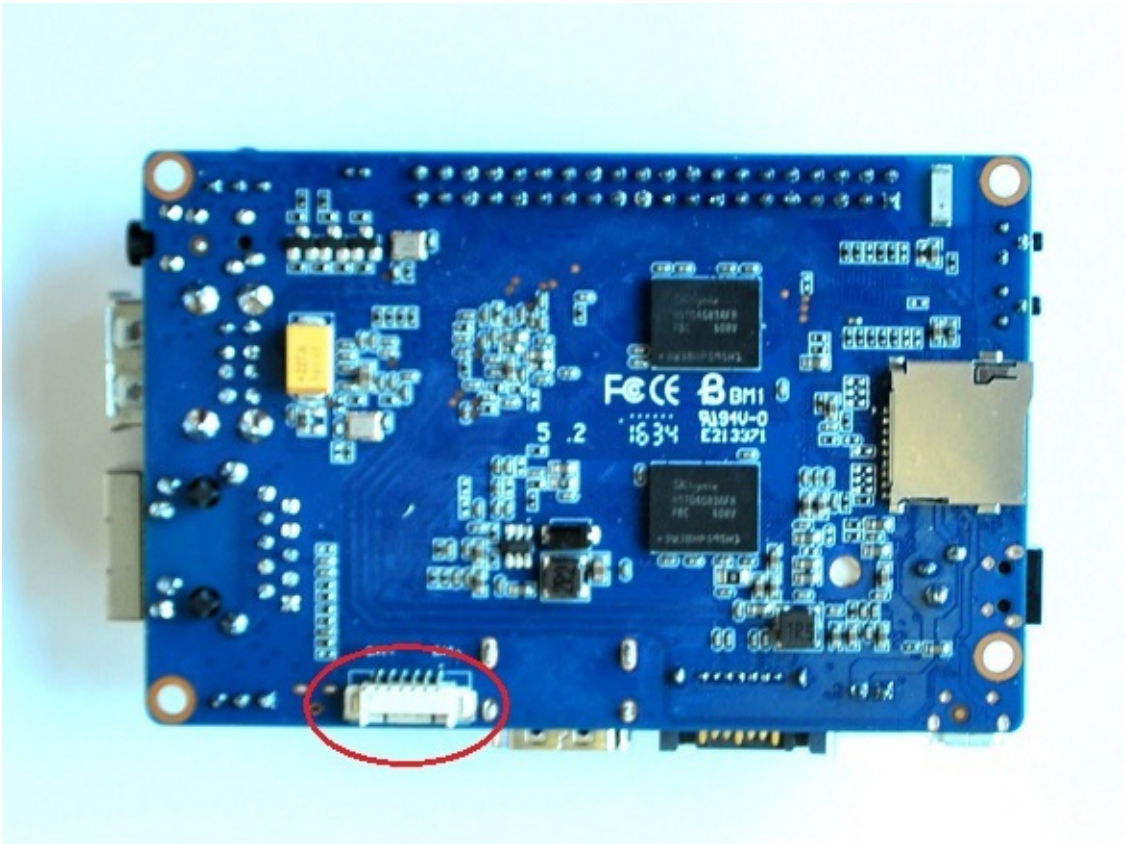

so

you can use this interfact connect 3.7V lithium battery.

SCH:

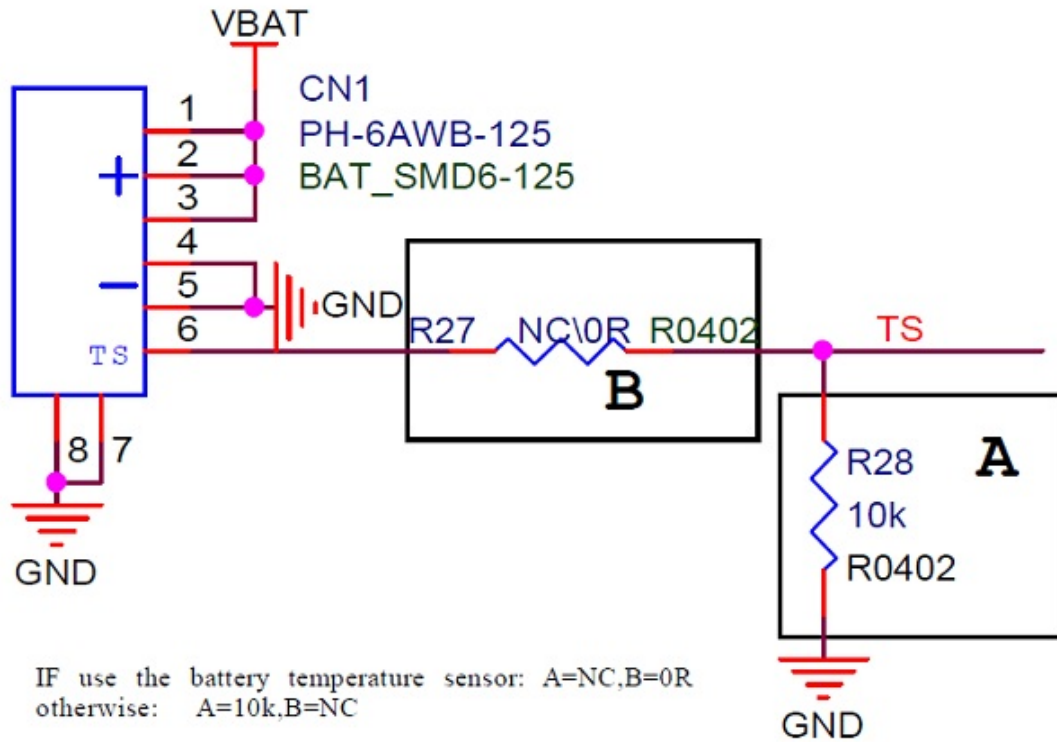

battery interface spec:

<https://drive.google.com/file/d/0B4PAo2nW2KfnSmVuVDhQc0NLdG8/view?usp=sharing>

BPI-M2 Ultra test 3.7V lithium battery interface with Ubuntu linux

Lithium battery discharge



Battery Charger



Lithium battery charger 100%



BPI-M2 Ultra Power interface

BPI-M2 Ultra power with DC port (default)

adapter same as BPI-M3,BPI-M64

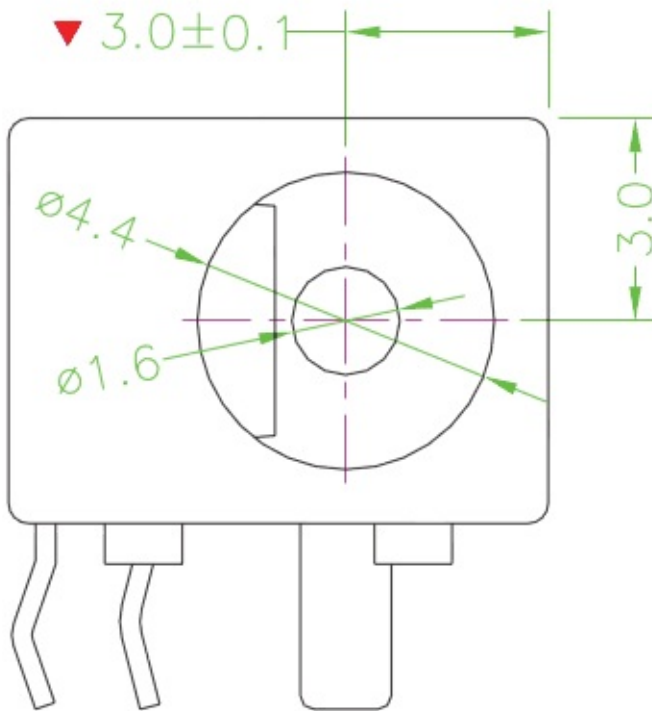

BPI-M2 Ultra power also support microUSB power (option)

BPI-M2 Utra DXF and 3D design

BPI-M2 Utra DXF file download link:

<https://drive.google.com/file/d/0B4PAo2nW2KfnX3pISmlGcVFoYTQ/view?usp=sharing>

Android image

[BPI-M2 Ultra & BPI-M2 Berry] New image: Android 6.0 (Version:V1) 2017-08-25

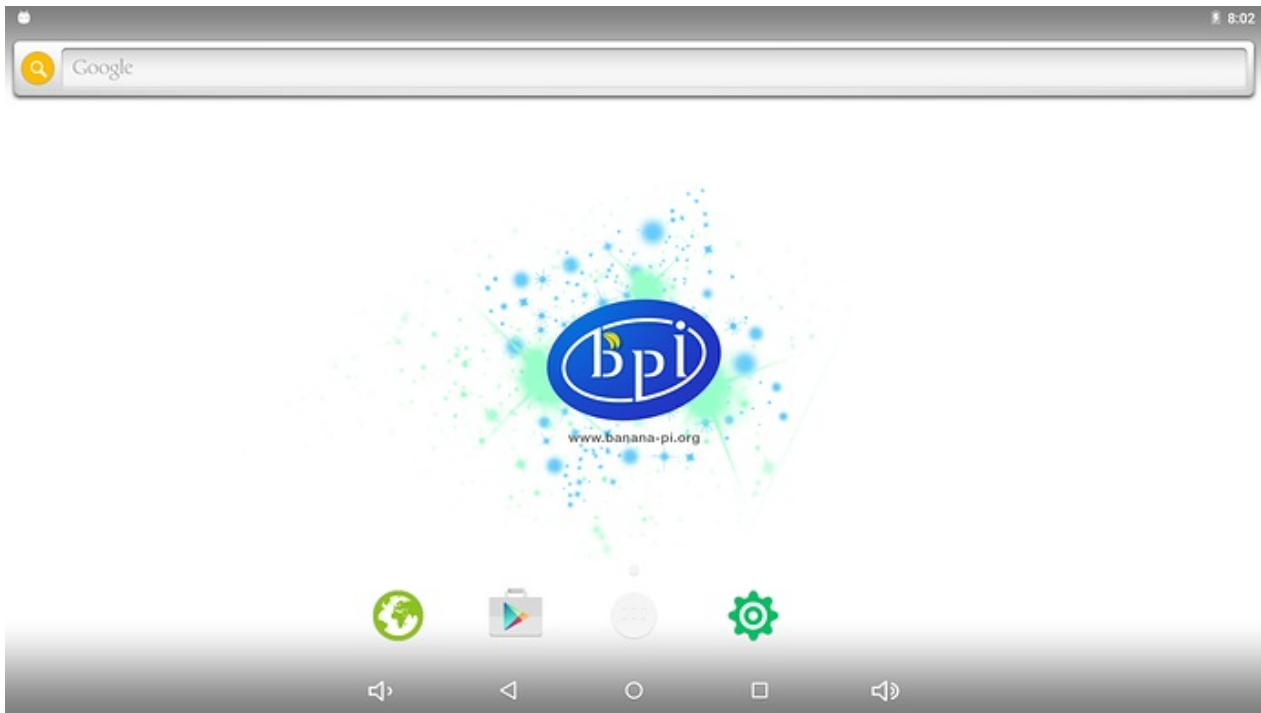

Git commit : 6ff036416a91c3373a7c85c4af2882af49d631fc

Release Note:

1. Android 6.0
2. GMAC supported
3. WIFI 802.11 b/g/n supported
4. Bluetooth 4.0 supported
5. USB Camera supported

Know isse:

1. Camera ov5640 not supported
2. MIC not supported
3. Headset not supported

HDMI-Version

Google Drive:

https://drive.google.com/open?id=0B_YnvHgh2rwjMIVUN2ZGcHlwdUE

Baidu Cloud:

MD5: c65fa4c20b8a6d2d05bfd32b090c3570

**LCD5-Version**

Google Drive:

https://drive.google.com/open?id=0B_YnvHgh2rwjWGRVay1va1oyWDg

Baidu Cloud:

MD5:f664e5fe0af20ebfc06ddc50bac1845b

**LCD7-Version**

Google Drive:

https://drive.google.com/open?id=0B_YnvHgh2rwjSHduUmRhSXR2Wik

Baidu Cloud:

MD5: 6cda3453d9524643c8f92fcdc8deb32f

discuss on forum :

<http://forum.banana-pi.org/t/bpi-m2-ultra-bpi-m2-berry-new-image-android-6-0-version-v1-2017-08-25/3731>

BPI-M2U] New image: Android6.0 (Beta Version)

Android 6.0 2017-03-06 for BPI-M2-Ultra

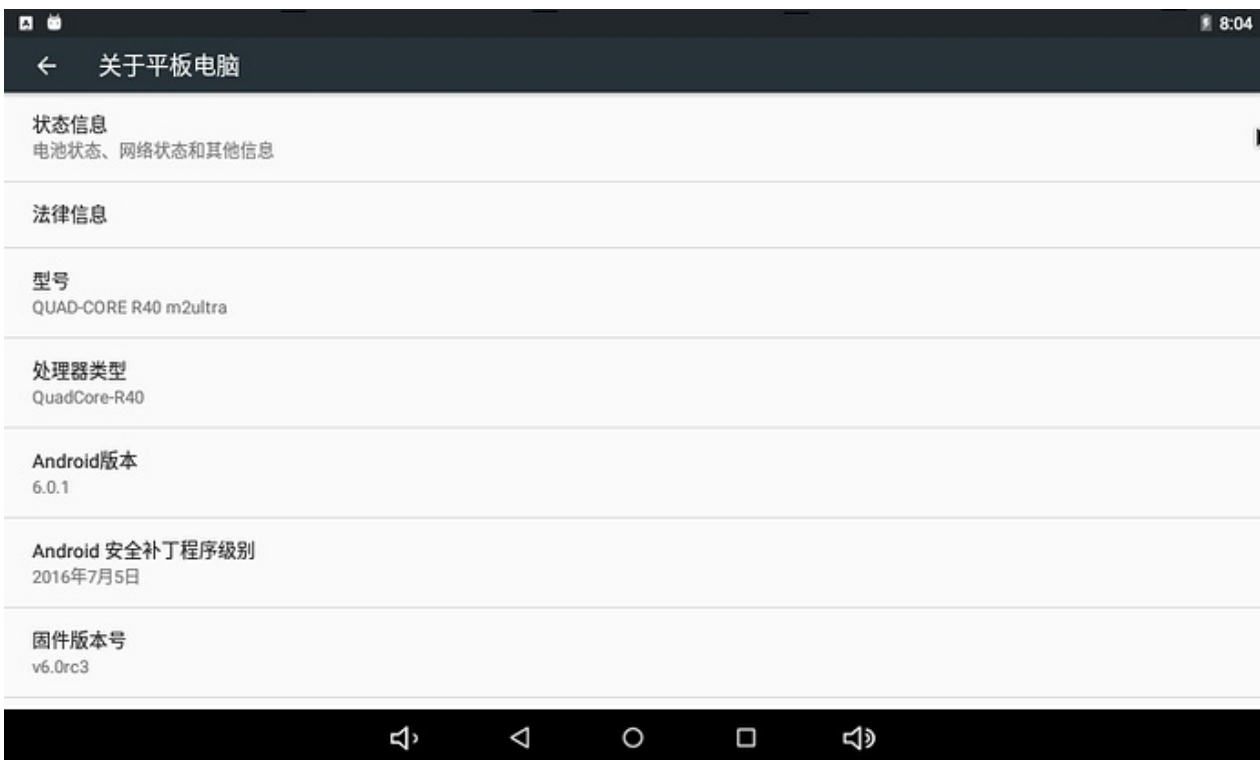
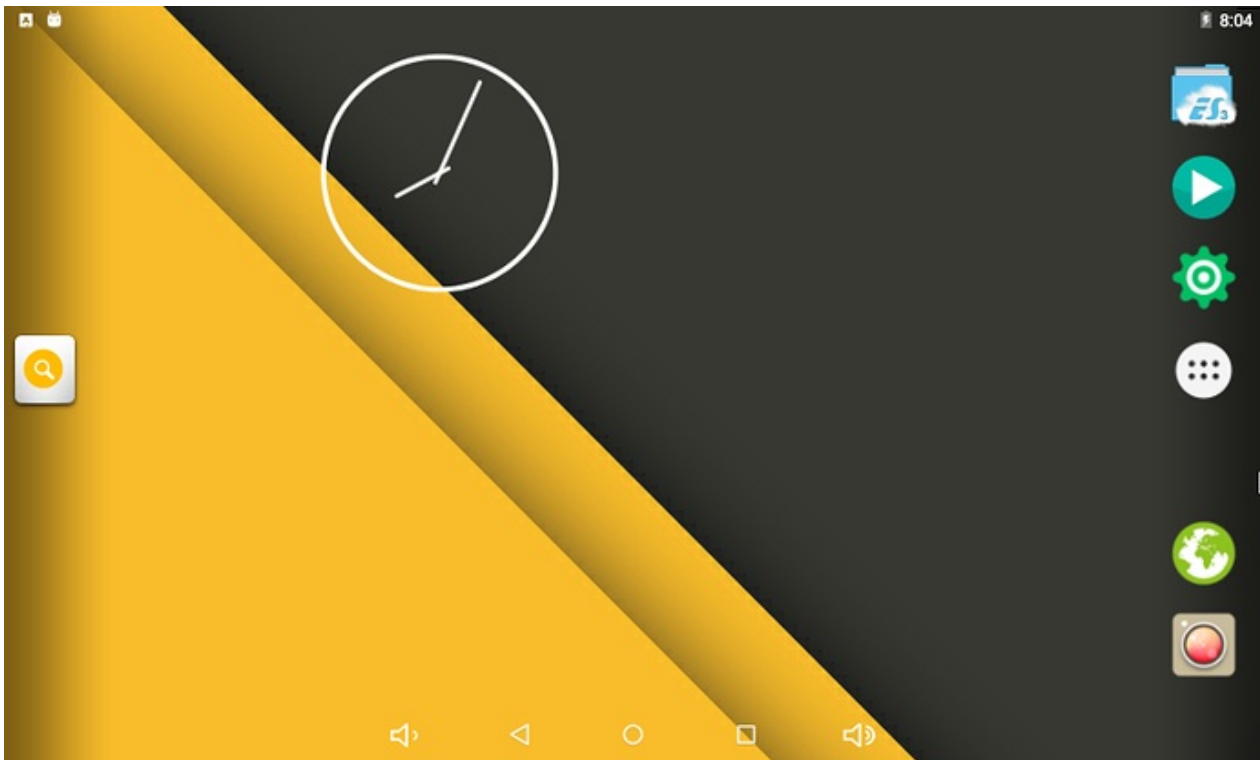

Release Note:

1. WIFI - Supported
2. GMAC - Supported
3. LCD Display- Supported

HDMI-Version & _LCD-Version_

banana pi BPI-M2 Ultra Android6 0 Demo

<https://www.youtube.com/watch?v=-6vtL3couxo>

Google Drive:

https://drive.google.com/open?id=0B_YnvHgh2rwjeTBiOEEzQmk5VXM

Baidu Cloud:

<http://pan.baidu.com/s/1pL2jnkV>

MD5: ae5ad08741fe1d06c4d901ea24d6971f

Video Demo on youtube:

<https://youtu.be/-6vtL3couxo>

discuss on forum :

<http://forum.banana-pi.org/t/bpi-m2u-new-image-android6-0-beta-version/2953>

Linux software image

BPI-M2 Ultra/Berry Ubuntu 16.04 image 2018-01-04

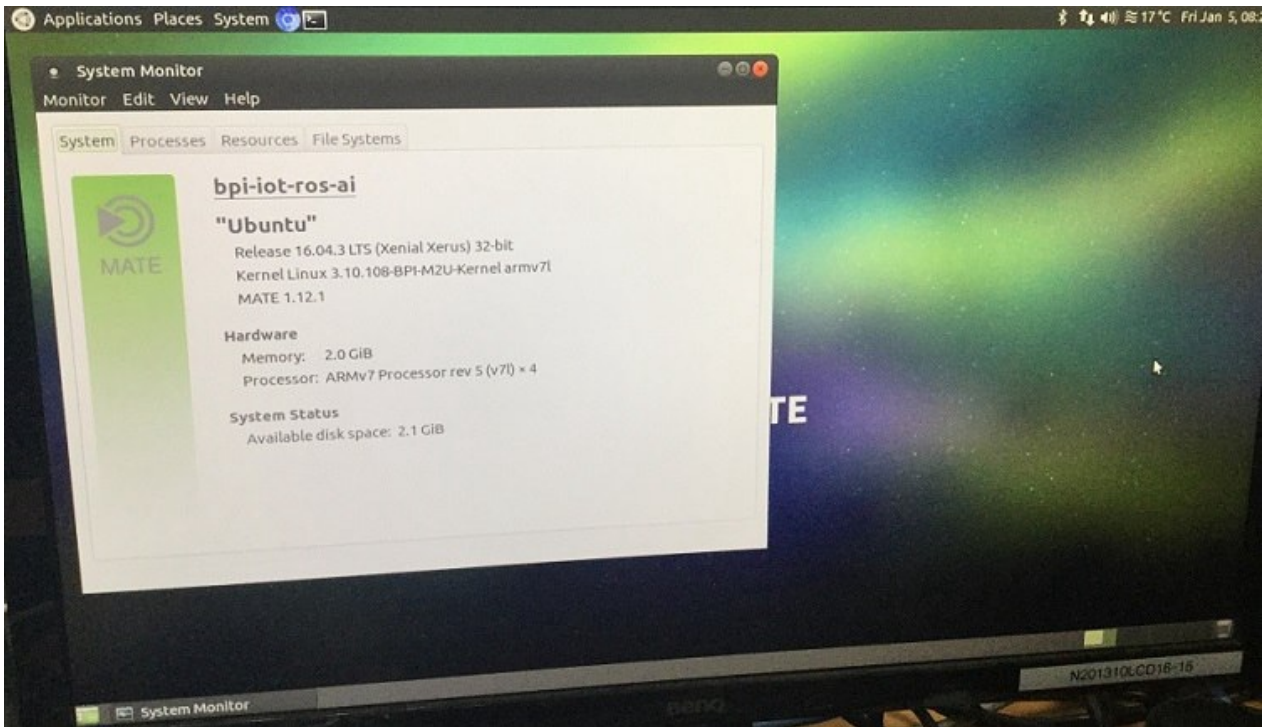

2018-01-04-ubuntu-16.04-mate-desktop-v1.0-bpi-m2u-sd-emmc.img.zip

Google Drive:

https://drive.google.com/file/d/1G4Ggkne63ofD51Yt2c-x5-qy9h7BgY4_/view?usp=sharing2

Baidu cloud:

<https://pan.baidu.com/s/1cFHYGY1>

MD5: a61e6f66a5ea2288fff0c3acff12d633

BPI-M2 Ultra/BPI-M2 Berry new image:2018-01-04-kali-xfce-desktop-v1.0-bpi-m2u-sd-emmc.img



2018-01-04-kali-xfce-desktop-v1.0-bpi-m2u-sd-emmc.img.zip

Google Drive:

<https://drive.google.com/file/d/1vvarGORZakY0esNaEBkC-KmmpDIQcwLN/view?usp=sharing>

MD5: 3f436a0fe437cca9c3f5417297ab538a

BPI-M2 Ultra/BPI-M2 Berry new image:2017-8-28 kali linux,cruX linux,archlinux,centos linux

google drive download link:

https://drive.google.com/drive/folders/0B_YnvHgh2rwjR0JsaUItaFXanc

BPI-M2 Ultra/BPI-M2 Berry new image:2017-08-28-debian-9-sd-emmc.img

****2017-08-28-debian-9-stretch-mate-desktop-preview-bpi-m2u-sd-emmc.img.zip****

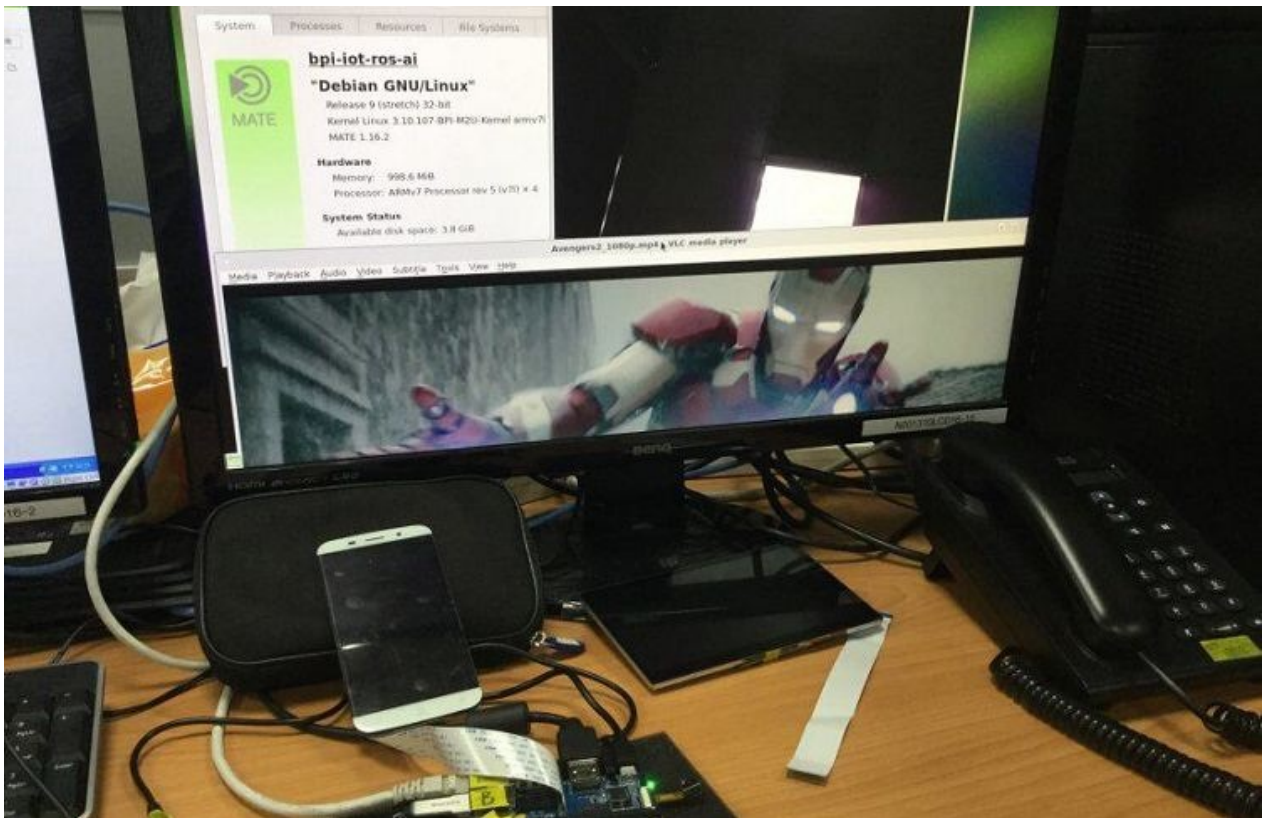

1. based on Debian Stretch 9.1 Mate Desktop
2. support BPI-M2 Ultra & BPI-M2 Berry kernel 3.10.107
3. username & password: pi/bananapi , root/bananapi
4. support LCD 7"
5. support LCD 5"
6. support HDMI 1080P & 480P & 720P (default)
7. support GMAC
8. support WIFI
9. support BT (with bluetoothctl can setup)
10. support SATA
11. support UART (default set 2 pin mode for /dev/ttyS2)
12. support I2C
13. support SPI
14. support eMMC (support boot from eMMC)
15. support Battery (BPI-M2 Ultra only)

16. support IR (getevent can test, BPI-M2 Ultra only)
17. support touch screen (can control desktop or getevent to test)
18. support power key (getevent can test)
19. support OTG (BPI-M2 Ultra only)
20. support CAMERA ov5640 (gucvview / cap / ffmpeg-3.2.1 support video H.264 hw encode)
21. support uEnv.txt to fatload ulmage
22. support bpi-bootsel to set LCD7" / LCD5" / HDMI (720P & 1080P & 480P)
23. support bpi-copy to write SD/eMMC with img.zip file
24. support video play 1080p with vdpau (vlc)
25. support chromium 60.0.3112.78
26. support wiringpi 2.44 (<https://github.com/BPI-SINOVOIP/BPI-WiringPi2>, thanks to <http://wiringpi.com/> & <https://github.com/WiringPi/WiringPi>)
27. support rpi.gpio 0.6.3 for python (<https://github.com/BPI-SINOVOIP/RPi.GPIO>, thanks to <https://sourceforge.net/projects/raspberry-gpio-python/>)
28. Thanks for linux-sunxi community (<http://linux-sunxi.org/>)
29. Special thanks for Daniel Andersen with BPI-M2U-bsp (<https://github.com/dan-and>)
30. Special thanks for Alex support with camera functions (<https://github.com/avafinger>)
31. ref. <https://github.com/BPI-SINOVOIP/BPI-M2U-bsp>
32. ref. <https://bananapi.gitbooks.io/bpi-m2-ultra-open-source-single-board-computer/content/>

Google Drive:

https://drive.google.com/file/d/0B_YnvHgh2rwjeTh4TmInMGI5X3M/view?usp=sharing

baidu cloud:

<http://pan.baidu.com/s/1c1LvS1y>

MD5: 0a1fad281c24902148b16276a79bac12

FILESIZE: 1008158558 (~961MB)

UNPACK: 7456MB (eMMC size)

BPI-M2 Ultra/BPI-M2 Berry new image:2017-08-27-debian-9-stretch-lite-preview-bpi-m2u-sd-emmc.img

**2017-08-27-debian-9-stretch-lite-preview-bpi-m2u-sd-emmc.img.zip

1. based on Debian Stretch 9.1
2. support BPI-M2 Ultra & BPI-M2 Berry kernel 3.10.107
3. username & password: pi/bananapi , root/bananapi
4. support LCD 7"
5. support LCD 5"
6. support HDMI 1080P & 480P & 720P (default)
7. support GMAC
8. support WIFI
9. support BT (with bluetoothctl can setup)
10. support SATA
11. support UART (default set 2 pin mode for /dev/ttyS2)
12. support I2C
13. support SPI
14. support eMMC (support boot from eMMC)
15. support Battery (BPI-M2 Ultra only)
16. support IR (getevent can test, BPI-M2 Ultra only)
17. support touch screen (getevent to test)
18. support power key (getevent can test)
19. support OTG (BPI-M2 Ultra only)
20. support CAMERA ov5640 (cap / ffmpeg-3.2.1 support video H.264 hw encode)
21. support uEnv.txt to fatload ulmage
22. support bpi-bootsel to set LCD7" / LCD5" / HDMI (720P & 1080P & 480P)
23. support bpi-copy to write SD/eMMC with img.zip file

24. support wiringpi 2.44 (<https://github.com/BPI-SINOVOIP/BPI-WiringPi2>, thanks to <http://wiringpi.com/> & <https://github.com/WiringPi/WiringPi>)
25. support rpi.gpio 0.6.3 for python (<https://github.com/BPI-SINOVOIP/RPi.GPIO> , thanks to <https://sourceforge.net/projects/raspberry-gpio-python/>)
26. Thanks for linux-sunxi community (<http://linux-sunxi.org/>)
27. Special thanks for Daniel Andersen with BPI-M2U-bsp (<https://github.com/dan-and>)
28. Special thanks for Alex support with camera functions (<https://github.com/avafinger>)
29. ref. <https://github.com/BPI-SINOVOIP/BPI-M2U-bsp>
30. ref. <https://bananapi.gitbooks.io/bpi-m2-ultra-open-source-single-board-computer/content/>

Google Drive:

https://drive.google.com/file/d/0B_YnvHgh2rwjOWg1OW9heWZsYm8/view?usp=sharing

baidu cloud:

<http://pan.baidu.com/s/1c3zxCy>

MD5: cff677aa94ca5345fc6e26379cfe4e95

FILESIZE: 532114076 (~507MB)

UNPACK: 7456MB (eMMC size)

BPI-M2 Ultra/BPI-M2 Berry new image: 2017-08-27-debian-8-jessie-lite-beta-bpi-m2u-sd-emmc.img

****2017-08-27-debian-8-jessie-lite-beta-bpi-m2u-sd-emmc.img.zip****

1. based on Debian Jessie 8.9
2. support BPI-M2 Ultra & BPI-M2 Berry kernel 3.10.107
3. username & password: pi/bananapi , root/bananapi
4. support LCD 7"
5. support LCD 5"
6. support HDMI 1080P & 480P & 720P (default)
7. support GMAC
8. support WIFI

9. support BT (with bluetoothctl can setup)
10. support SATA
11. support UART (default set 2 pin mode for /dev/ttyS2)
12. support I2C
13. support SPI
14. support eMMC (support boot from eMMC)
15. support Battery (BPI-M2 Ultra only)
16. support IR (getevent can test, BPI-M2 Ultra only)
17. support touch screen (getevent to test)
18. support power key (getevent can test)
19. support OTG (BPI-M2 Ultra only)
20. support CAMERA ov5640 (cap / ffmpeg-3.2.1 support video H.264 hw encode)
21. support uEnv.txt to fatload ulmage
22. support bpi-bootsel to set LCD7" / LCD5" / HDMI (720P & 1080P & 480P)
23. support bpi-copy to write SD/eMMC with img.zip file
24. support wiringpi 2.44 (<https://github.com/BPI-SINOVOIP/BPI-WiringPi2> , thanks to <http://wiringpi.com/> & <https://github.com/WiringPi/WiringPi>)
25. support rpi.gpio 0.6.3 for python (<https://github.com/BPI-SINOVOIP/RPi.GPIO> , thanks to <https://sourceforge.net/projects/raspberry-gpio-python/>)
26. Thanks for linux-sunxi community (<http://linux-sunxi.org/>)
27. Special thanks for Daniel Andersen with BPI-M2U-bsp (<https://github.com/dan-and>)
28. Special thanks for Alex support with camera functions (<https://github.com/avafinger>)
29. ref. <https://github.com/BPI-SINOVOIP/BPI-M2U-bsp>
30. ref. <https://bananapi.gitbooks.io/bpi-m2-ultra-open-source-single-board-computer/content/>

Google Drive:

https://drive.google.com/file/d/0B_YnvHgh2rwjcDJGTnhqN3Nsb2M/view?usp=sharing

baidu cloud:

<http://pan.baidu.com/s/1mhEueaG>

MD5: 049e78cc668c5edb5346d7f9e7fb0a51

FILESIZE: 452988068 (~432MB)

UNPACK: 7456MB (eMMC size)

Test video demo:

<https://www.youtube.com/watch?v=atlwr9uLPw>

discuss on forum:

<http://forum.banana-pi.org/t/bpi-m2-ultra-bpi-m2-berry-new-image-2017-08-28-debian-sd-emmc-img/3745>

BPI-M2 Ultra/BPI-M2 Berry new image: 2017-08-25-raspbian-stretch-preview-bpi-m2u-sd-emmc

2017-08-25-raspbian-stretch-preview-bpi-m2u-sd-emmc.img.zip

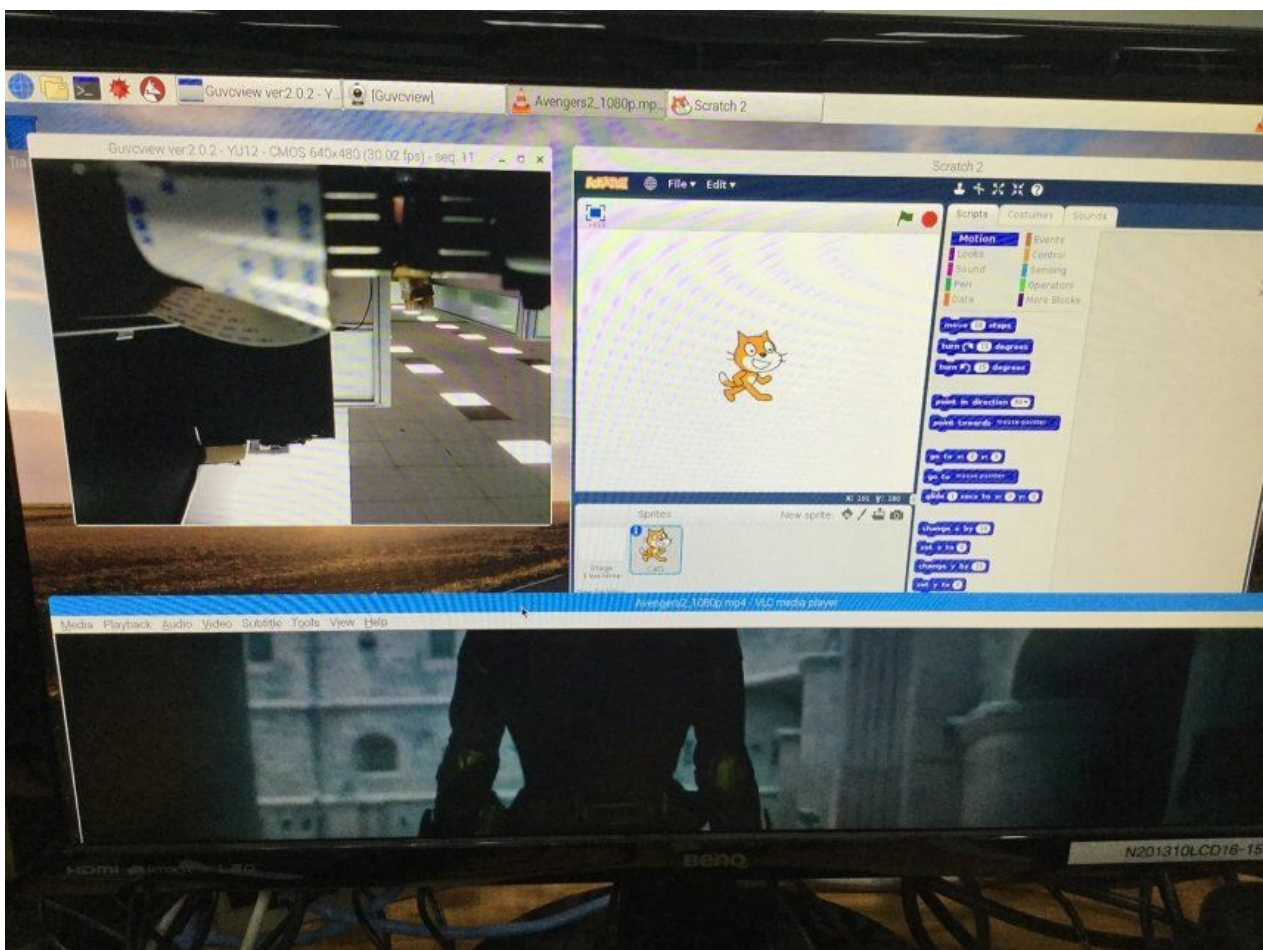

1. based on RASPBIAN STRETCH 9.1 2017-08-16 (support rpi3 rpi2 rpi1)
2. support BPI-M2 Ultra & BPI-M2 Berry kernel 3.10.107

3. username & password: pi/bananapi , root/bananapi
4. support LCD 7"
5. support LCD 5"
6. support HDMI 1080P & 480P & 720P (default)
7. support GMAC
8. support WIFI
9. support BT (with bluetoothctl can setup)
10. support SATA
11. support UART (default set 2 pin mode for /dev/ttyS2)
12. support I2C
13. support SPI
14. support eMMC (support boot from eMMC)
15. support Battery (BPI-M2 Ultra only)
16. support IR (getevent can test, BPI-M2 Ultra only)
17. support touch screen (can control desktop or getevent to test)
18. support power key (getevent can test)
19. support OTG (BPI-M2 Ultra only)
20. support CAMERA ov5640 (gucvview / cap / ffmpeg-3.2.1 support video H.264 hw encode)
21. support uEnv.txt to fatload ulmage
22. support bpi-bootsel to set LCD7" / LCD5" / HDMI (720P & 1080P & 480P)
23. support bpi-copy to write SD/eMMC with img.zip file
24. support video play 1080p with vdpau (vlc)
25. support chromium 60.0.3112.89
26. support scratch 1.4
27. support scratch 2

28. support wiringpi 2.44 (<https://github.com/BPI-SINOVOIP/BPI-WiringPi2>, thanks to <http://wiringpi.com/> & <https://github.com/WiringPi/WiringPi>)
29. support rpi.gpio 0.6.3 for python (<https://github.com/BPI-SINOVOIP/RPi.GPIO>, thanks to <https://sourceforge.net/projects/raspberry-gpio-python/>)
30. thanks for raspberry.org's work (<https://www.raspberrypi.org/downloads/raspbian>)
31. Thanks for linux-sunxi community (<http://linux-sunxi.org/>)
32. Special thanks for Daniel Andersen with BPI-M2U-bsp (<https://github.com/dan-and>)
33. Special thanks for Alex support with camera functions (<https://github.com/avafinger>)
34. ref. <https://github.com/BPI-SINOVOIP/BPI-M2U-bsp>
35. ref. <https://bananapi.gitbooks.io/bpi-m2-ultra-open-source-single-board-computer/content/>

Google Drive:

https://drive.google.com/file/d/0B_YnvHgh2rwjeFIUYk9fSmRkVjg/view?usp=sharing

baidu cloud:

<http://pan.baidu.com/s/1hsoZKEC>

MD5: ea86f99c9e0a946dddfa3f4a2ec39dc0

FILESIZE: 1919429092 (~1830MB)

UNPACK: 7456MB (eMMC size)

Discuss on forum :

<http://forum.banana-pi.org/t/bpi-m2-ultra-bpi-m2-berry-new-image-2017-08-25-raspbian-stretch-preview-bpi-m2u-sd-emmc/3741>

BPI-M2 Ultra/BPI-M2 Berry new image:2017-08-24-raspbian-jessie-beta-bpi-m2u-sd-emmc.img

2017-08-24-raspbian-jessie-beta-bpi-m2u-sd-emmc.img.zip



1. based on RASPBIAN JESSIE (support rpi3 rpi2 rpi1)
2. support BPI-M2 Ultra & BPI-M2 Berry kernel 3.10.107
3. username & password: pi/bananapi , root/bananapi
4. support LCD 7"
5. support LCD 5"
6. support HDMI 1080P & 480P & 720P (default)
7. support GMAC
8. support WIFI
9. support BT (with bluetoothctl can setup)
10. support SATA
11. support UART (default set 2 pin mode for /dev/ttyS2)
12. support I2C
13. support SPI
14. support eMMC (support boot from eMMC)
15. support Battery (BPI-M2 Ultra only)
16. support IR (getevent can test, BPI-M2 Ultra only)

17. support touch screen (getevent to test, control desktop please try raspbian stretch version)
18. support power key (getevent can test)
19. support OTG (BPI-M2 Ultra only)
20. support CAMERA ov5640 (gucvview / cap / ffmpeg-3.2.1 support video H.264 hw encode)
21. support uEnv.txt to fatload ulmage
22. support bpi-bootsel to set LCD7" / LCD5" / HDMI (720P & 1080P & 480P)
23. support bpi-copy to write SD/eMMC with img.zip file
24. support video play 1080p with vdpau (vlc)
25. support chromium 56.0.2924.84
26. support wiringpi 2.44 (<https://github.com/BPI-SINOVOIP/BPI-WiringPi2>, thanks to <http://wiringpi.com/> & <https://github.com/WiringPi/WiringPi>)
27. support rpi.gpio 0.6.3 for python (<https://github.com/BPI-SINOVOIP/RPi.GPIO>, thanks to <https://sourceforge.net/projects/raspberry-gpio-python/>)
28. thanks for raspberry.org's work (<https://www.raspberrypi.org/downloads/raspbian/>)
29. Thanks for linux-sunxi community (<http://linux-sunxi.org/>)
30. Special thanks for Daniel Andersen with BPI-M2U-bsp (<https://github.com/dan-and/>)
31. Special thanks for Alex support with camera functions (<https://github.com/avafinger/>)
32. ref. <https://github.com/BPI-SINOVOIP/BPI-M2U-bsp>
33. ref. <https://bananapi.gitbooks.io/bpi-m2-ultra-open-source-single-board-computer/content/>

Google Drive:

https://drive.google.com/file/d/0B_YnvHgh2rwjNDdwRIMyNk94cFk/view?usp=sharing

baidu cloud:

<http://pan.baidu.com/s/1i4PVqVr>

MD5: 680cae4389def603fdc50df3d20d49e3

FILESIZE: 1960302379 (~1869MB)

UNPACK: 7456MB (eMMC size)

discuss on forum :

<http://forum.banana-pi.org/t/bpi-m2-ultra-bpi-m2-berry-new-image-2017-08-24-raspbian-jessie-beta-bpi-m2u-sd-emmc-img/3742>

Banana pi BPI-M2 Ultra/BPI-M2 Berry new image:2017-08-24-ubuntu-16.04-mate-desktop-beta



release version note:

1. based on ubuntu 16.04.3 LTS Mate Desktop
2. support BPI-M2 Ultra & BPI-M2 Berry kernel 3.10.107
3. username & password: pi/bananapi , root/bananapi
4. support LCD 7"
5. support LCD 5"
6. support HDMI 1080P & 480P & 720P
7. support GMAC
8. support WIFI
9. support BT (with bluetoothctl can setup)

10. support SATA
11. support UART (default set 2 pin mode for /dev/ttyS2)
12. support I2C
13. support SPI
14. support eMMC (support boot from eMMC)
15. support Battery (BPI-M2 Ultra only)
16. support IR (getevent can test, BPI-M2 Ultra only)
17. support touch screen (can control desktop or getevent to test)
18. support power key (getevent can test)
19. support OTG (BPI-M2 Ultra only)
20. support CAMERA ov5640 (gucvview / cap / ffmpeg-3.2.1 support video H.264 hw encode)
21. support uEnv.txt to fatload ulmage
22. support bpi-bootsel to set LCD7" / LCD5" / HDMI (720P & 1080P & 480P)
23. support bpi-copy to write SD/eMMC with img.zip file
24. support video play 1080p with vdpau (mpv , vlc, smplayer)
25. support xrdp
26. support chromium 60.0.3112.78
27. support wiringpi 2.44 (<https://github.com/BPI-SINOVOIP/BPI-WiringPi2> , thanks to <http://wiringpi.com/> & <https://github.com/WiringPi/WiringPi>)
28. support rpi.gpio 0.6.3 for python (<https://github.com/BPI-SINOVOIP/RPi.GPIO>, thanks to <https://sourceforge.net/projects/raspberry-gpio-python/>)
29. Thanks for linux-sunxi community (<http://linux-sunxi.org/>)
30. Special thanks for Daniel Andersen with BPI-M2U-bsp (<https://github.com/dan-and>)
31. Special thanks for Alex support with camera functions (<https://github.com/avafinger>)
32. ref. <https://github.com/BPI-SINOVOIP/BPI-M2U-bsp>
33. ref. <https://bananapi.gitbooks.io/bpi-m2-ultra-open-source-single-board-computer/content/>

HDMI version:

file name: 2017-08-24-ubuntu-16.04-mate-desktop-beta-bpi-m2u-sd-emmc.img.zip

Google Drive:

https://drive.google.com/file/d/0B_YnvHgh2rwjM1A5UjVpWUdDdk0/view?usp=sharing

baidu cloud:

<http://pan.baidu.com/s/1hr5E49Q>

MD5: 5ce6251d0b5d834eecbb7ec51302383c

FILESIZE: 1808529214 (~1724MB)

UNPACK: 7456MB (eMMC size)

LCD 7.0 version:

filename: 2017-08-24-ubuntu-16.04-mate-desktop-beta-bpi-m2u-lcd7-sd-emmc.img.zip

Google Drive:

https://drive.google.com/file/d/0B_YnvHgh2rwjOENqYWtja0pENjA/view?usp=sharing

baidu cloud:

<http://pan.baidu.com/s/1sl5CxFR>

MD5: 41c3ec53795f5d9c309bb6e32e478a52

FILESIZE: 1809255540 (~1725MB)

UNPACK: 7456MB (eMMC size)

LCD 5.0 version:

filename: 2017-08-24-ubuntu-16.04-mate-desktop-beta-bpi-m2u-lcd5-sd-emmc.img.zip

Google Drive:

https://drive.google.com/file/d/0B_YnvHgh2rwjV3JISE1zdnZHQjQ/view?usp=sharing

baidu cloud:

<http://pan.baidu.com/s/1jHDHXci>

MD5: 9c460e2a83aed6b93ee53920d72cbe09

FILESIZE: 1807400340 (~1723MB)

UNPACK: 7456MB (eMMC size)

Disuss on forum :

<http://forum.banana-pi.org/t/banana-pi-bpi-m2-ultra-bpi-m2-berry-new-image-2017-08-24-ubuntu-16-04-mate-desktop-beta-bpi-m2u-m2b/3725>

Banana pi BPI-M2 Ultra/BPI-M2 Berry new image:Ubuntu-16.04-mate-desktop-beta-bpi-m2u-sd-emmc-2017-07-10

file name: 2017-07-10-ubuntu-16.04-mate-desktop-beta-bpi-m2u-sd-emmc.img.zip

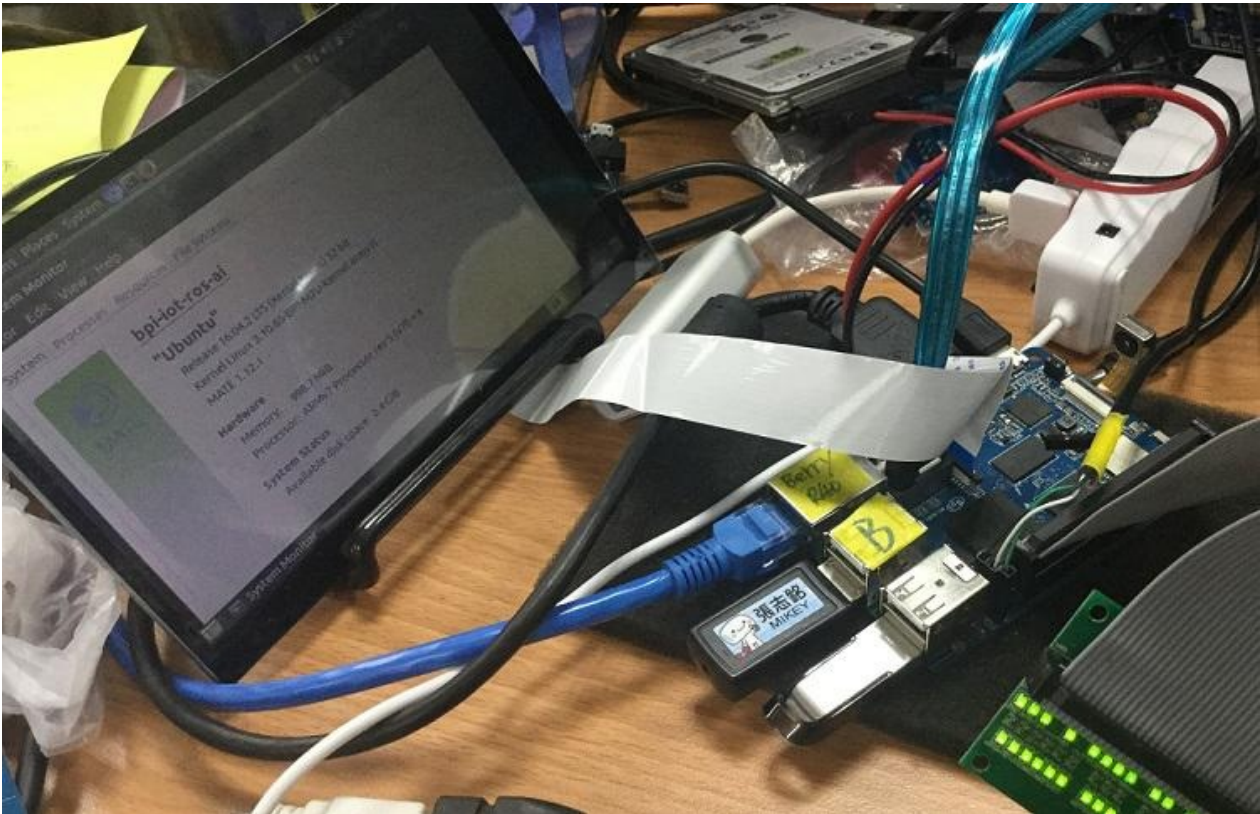

1. based on ubuntu 16.04.2 LTS Mate Desktop
2. support BPI-M2 Ultra & BPI-M2 Berry kernel 3.10.65
3. username & password: pi/bananapi , root/bananapi
4. support LCD 7"
5. support LCD 5"
6. support HDMI 1080P & 480P & 720P (default)
7. support GMAC
8. support WIFI
9. support BT (with bluetoothctl can setup)
10. support SATA

11. support UART (default set 2 pin mode for /dev/ttyS2)
12. support eMMC (support boot from eMMC)
13. support Battery (BPI-M2 Ultra only)
14. support IR (getevent can test, BPI-M2 Ultra only)
15. support touch screen (can control desktop or getevent to test)
16. support power key (getevent can test)
17. support OTG & adbd (default off)
18. support CAMERA ov5640 (gview / cap / ffmpeg-3.2.1 support video H.264 hw encode)
19. support uEnv.txt to fatload ulmage
20. support bpi-bootsel to set LCD7" / LCD5" / HDMI (720P & 1080P & 480P)
21. support bpi-copy to write SD/eMMC with img.zip file
22. support video play 1080p with vdpau (mpv)
23. support wiringpi 2.44 (<https://github.com/BPI-SINOVOIP/WiringPi>, thanks to <http://wiringpi.com/> & <https://github.com/WiringPi/WiringPi>)
24. support rpi.gpio 0.6.3 for python (<https://github.com/BPI-SINOVOIP/RPi.GPIO>, thanks to <https://sourceforge.net/projects/raspberry-gpio-python/>)
25. Thanks for linux-sunxi community (<http://linux-sunxi.org/>)
26. Special thanks for Alex support with camera functions (<https://github.com/avafinger/>)

Google Drive:

https://drive.google.com/file/d/0B_YnvHgh2rwjam5HYS0zU013bDQ/view?usp=sharing

baidu cloud:

<http://pan.baidu.com/s/1cjd8SY>

MD5: b10a243031f5c819220857ff3c2f61a2

FILESIZE: 1693544540 (~1616MB)

UNPACK: 7456MB (eMMC size)

Banana pi BPI-M2 Ultra/BPI-M2 Berry new image :2017-05-25-ubuntu-16.04-mate-desktop-preview2-bpi-m2u-sd-emmc.img

2017-05-25-ubuntu-16.04-mate-desktop-preview2-bpi-m2u-sd-emmc.img.zip



1. based on ubuntu 16.04.2 LTS Mate Desktop
2. support BPI-M2 Ultra & BPI-M2 Berry kernel 3.10.65
3. username & password: pi/bananapi , root/bananapi
4. support LCD 7"
5. support LCD 5"
6. support HDMI 1080P & 480P & 720P (default)
7. support GMAC
8. support WIFI
9. support BT (with bluetoothctl can setup)
10. support SATA
11. support eMMC (support boot from eMMC)
12. support Battery (BPI-M2 Ultra only)
13. support IR (getevent can test, BPI-M2 Ultra only)
14. support touch screen (can control desktop or getevent to test)

14 support power key (getevent can test)

1. support OTG & abbd (default off)
2. support CAMERA ov5640 (gucvview / cap / ffmpeg-3.2.1 support video H.264 hw encode)
3. support uEnv.txt to fatload ulmage
4. support bpi-bootsel to set LCD7" / LCD5" / HDMI (720P & 1080P & 480P)
5. support bpi-copy to write SD/eMMC with img.zip file
6. support video play 1080p with vdpau (mpv)
7. support wiringpi 2.44 (<https://github.com/BPI-SINOVOIP/WiringPi>, thanks to <http://wiringpi.com/> & <https://github.com/WiringPi/WiringPi>)
8. support rpi.gpio 0.6.3 for python (<https://github.com/BPI-SINOVOIP/RPi.GPIO>, thanks to <https://sourceforge.net/projects/raspberry-gpio-python/>)
9. Thanks for linux-sunxi community (<http://linux-sunxi.org/>)
10. Special thanks for Alex support with camera functions (<https://github.com/avafinger/>)

Google Drive:

https://drive.google.com/file/d/0B_YnvHgh2rwjN2xyOTF1aEFZelU/view?usp=sharing

baidu cloud:

<https://pan.baidu.com/s/1mi3FApq>

MD5: f1ecb49e30724733be7c1cfda8d110c3

FILESIZE: 1730996488 (~1650MB)

UNPACK: 7456MB (eMMC size)

Banana pi BPI-M2 Ultra/BPI-M2 Berry new image : 2017-05-25-raspbian-jessie-preview3-bpi-m2u-sd-emmc.img

2017-05-25-raspbian-jessie-preview3-bpi-m2u-sd-emmc.img.zip

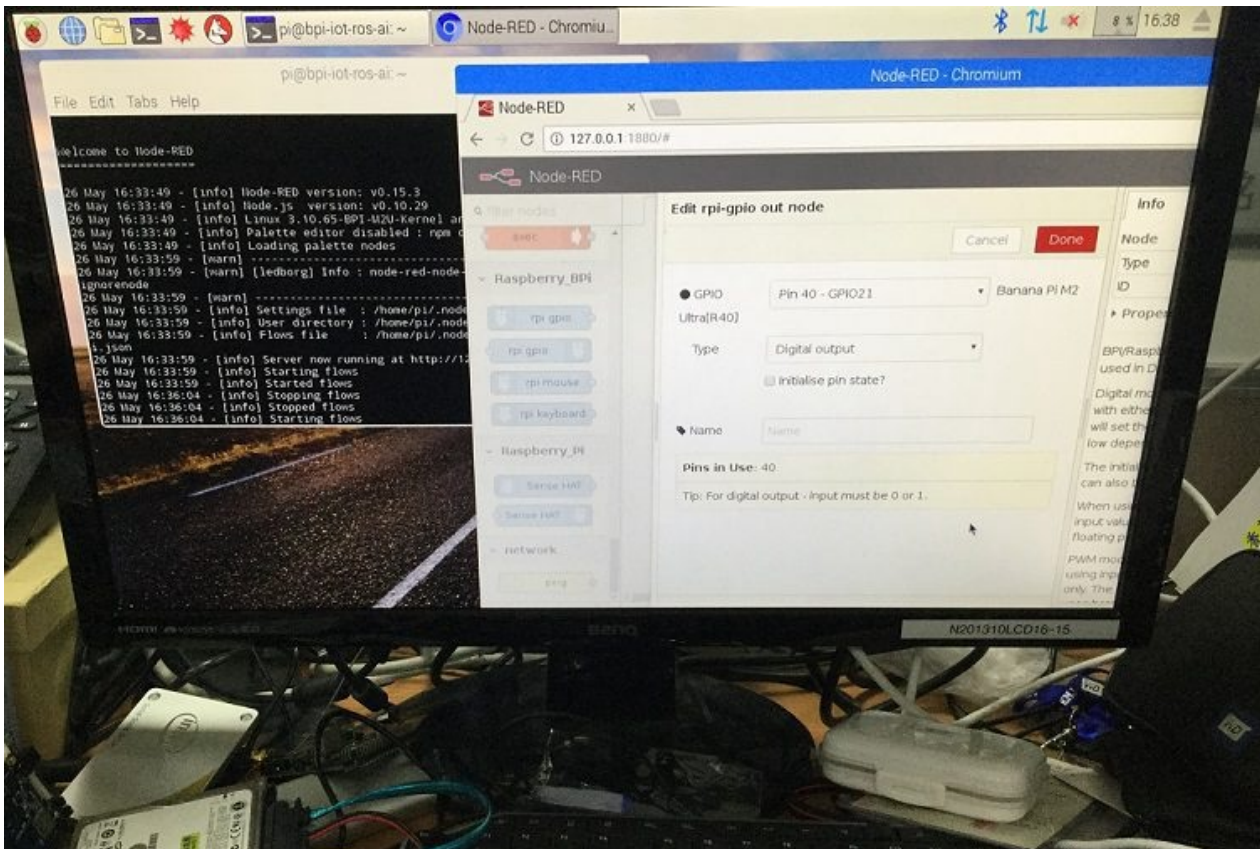

1. based on RASPBIAN JESSIE 2017-04-10 (support rpi3 rpi2 rpi1)
2. support BPI-M2 Ultra & BPI-M2 Berry kernel 3.10.65
3. username & password: pi/bananapi , root/bananapi
4. support LCD 7"
5. support LCD 5"
6. support HDMI 1080P & 480P & 720P (default)
7. support GMAC
8. support WIFI
9. support BT (with bluetoothctl can setup)
10. support SATA
11. support eMMC (support boot from eMMC, BPI-M2 Ultra only)
12. support Battery (BPI-M2 Ultra only)
13. support IR (getevent can test, BPI-M2 Ultra only)
14. support touch screen (getevent to test)
- 14 support power key (getevent can test)

1. support OTG & addb (default off)
2. support CAMERA ov5640 (gucvview / cap / ffmpeg-3.2.1 support video H.264 hw encode)
3. support uEnv.txt to fatload ulmage
4. support bpi-bootsel to set LCD7" / LCD5" / HDMI (720P & 1080P & 480P)
5. support bpi-copy to write SD/eMMC with img.zip file
6. support video play 1080p with vdpau (vlc)
7. support wiringpi 2.44 (<https://github.com/BPI-SINOVOIP/WiringPi>, thanks to <http://wiringpi.com/> & <https://github.com/WiringPi/WiringPi>)
8. support rpi.gpio 0.6.3 for python (<https://github.com/BPI-SINOVOIP/RPi.GPIO>, thanks to <https://sourceforge.net/projects/raspberry-gpio-python/>)
9. Thanks for linux-sunxi community (<http://linux-sunxi.org/>)
10. Special thanks for Alex support with camera functions (<https://github.com/avafinger/>)
11. thanks for raspberry.org's work(<https://www.raspberrypi.org/downloads/raspbian/>)
12. support node-red with raspberrypi's node to control gpio

Google Drive:

https://drive.google.com/file/d/0B_YnvHgh2rwjRGIUMUdqZk5ETDg/view?usp=sharing

baidu cloud:

<https://pan.baidu.com/s/1civq4e>

MD5: 60e19ea9138d6841fa6852ece4727b0a

FILESIZE: 1946658225(~1856MB)

UNPACK: 7456MB (eMMC size)

Discuss on forum:

<http://forum.banana-pi.org/t/banana-pi-bpi-m2-ultra-bpi-m2-berry-new-image-2017-05-25-raspbian-jessie-preview3-bpi-m2u-sd-emmc-img/3306>

BPI-M2 Ultra new image:debian-8-jessie-lite-beta2-bpi-m2u-sd-emmc.img 2016-11-

29



debian 8 with LCD scree and power with lithium battery

based on debian 8 jessie (text mode)

BPI-M2U kernel 3.10.65

username & password: pi/bananapi , root/bananapi

support LCD 7" (default)

support HDMI 1080P & 480P & 720P

support GMAC

support WIFI

support BT (with bluetoothctl can setup)

support SATA

support eMMC (support boot from eMMC)

support Battery

support IR (getevent can test)

support Touch Screen (getevent can test)

13 support Power Key (getevent can test)

support OTG & addb (default on)

support CAMERA ov5640 (tinacameratest app support photo / video H.264 hw encode)

support uEnv.txt to fatload ulmage

support bpi-bootsel to set LCD7 or HDMI (720P & 1080P & 480P)

support bpi-copy to write SD/eMMC with img.zip file

LCD version:

2016-11-29-debian-8-jessie-lite-beta2-bpi-m2u-lcd7-sd-emmc.img.zip

Google Drive:

https://drive.google.com/file/d/0B_YnvHgh2rwjc3Rkd3IPcl9hS00/view?usp=sharing

baidu cloud:

<https://pan.baidu.com/s/1jl2UePo>

MD5: 709e2efe4945ed22e4fe0212a31e3d12

FILESIZE: 403577975 (~385MB)

UNPACK: 7456MB (eMMC size)

discuss on forum:

<http://forum.banana-pi.org/t/bpi-m2-ultra-new-image-debian-8-jessie-lite-beta2-bpi-m2u-lcd7-sd-emmc-img-2016-11-29/2520>

HDMI version:

2016-11-29-debian-8-jessie-lite-beta2-bpi-m2u-sd-emmc.img.zip

Google Drive:

https://drive.google.com/file/d/0B_YnvHgh2rwjR0p6WVUwbU5JcVk/view?usp=sharing

baidu cloud:

<https://pan.baidu.com/s/1skDUQmT>

MD5: 55d2da5ad204c578613b17517b87266a

FILESIZE: 403662152 (~385MB)

UNPACK: 7456MB (eMMC size)

discuss on forum:

<http://forum.banana-pi.org/t/bpi-m2-ultra-new-image-debian-8-jessie-lite-beta2-bpi-m2u-sd-emmc-img-2016-11-29/2521>

BPI-M2 Ultra new image :ubuntu-16.04.1-mate-desktop-preview3-bpi-m2u-lcd7-sd-

emmc.img 2016-11-29

2016-11-29-ubuntu-16.04.1-mate-desktop-preview3-bpi-m2u-lcd7-sd-emmc.img.zip



1. based on ubuntu 16.04.1 LTS Mate Desktop
2. BPI-M2U kernel 3.10.65
3. username & password: pi/bananapi , root/bananapi
4. support LCD 7" (default)
5. support HDMI 1080P & 480P & 720P
6. support GMAC
7. support WIFI
8. support BT (with bluetoothctl can setup)
9. support SATA
10. support eMMC (support boot from eMMC)
11. support Battery
12. support IR (getevent can test)
13. support touch screen (can control desktop or getevent to test) 13 support power key (getevent can test)
14. support OTG & abdb (default on)
15. support CAMERA ov5640 (tinacameratest app support photo / video H.264 hw encode)
16. support uEnv.txt to fatload ulmage
17. support bpi-bootsel to set LCD7 or HDMI (720P & 1080P & 480P)
18. support bpi-copy to write SD/eMMC with img.zip file

19. support video play 1080p with vdpau (mpv)
20. support nodejs
21. support node-red

Google Drive:

https://drive.google.com/file/d/0B_YnvHgh2rwjRW82Sm9PTWFMREU/view?usp=sharing

baidu cloud:

<https://pan.baidu.com/s/1i5NoVTb>

MD5: 32204d2f4a0b58536403783989f8c514

FILESIZE: 2024613864 (~1931MB)

UNPACK: 7456MB (eMMC size)

discuss on forum :

<http://forum.banana-pi.org/t/bpi-m2-ultra-new-image-ubuntu-16-04-1-mate-desktop-preview3-bpi-m2u-lcd7-sd-emmc-img-2016-11-29/2501>

BPI-M2 Ultra new image:ubuntu-16.04.1-mate-desktop-preview3-bpi-m2u-sd-emmc.img 2016-11-29

2016-11-29-ubuntu-16.04.1-mate-desktop-preview3-bpi-m2u-sd-emmc.img.zip

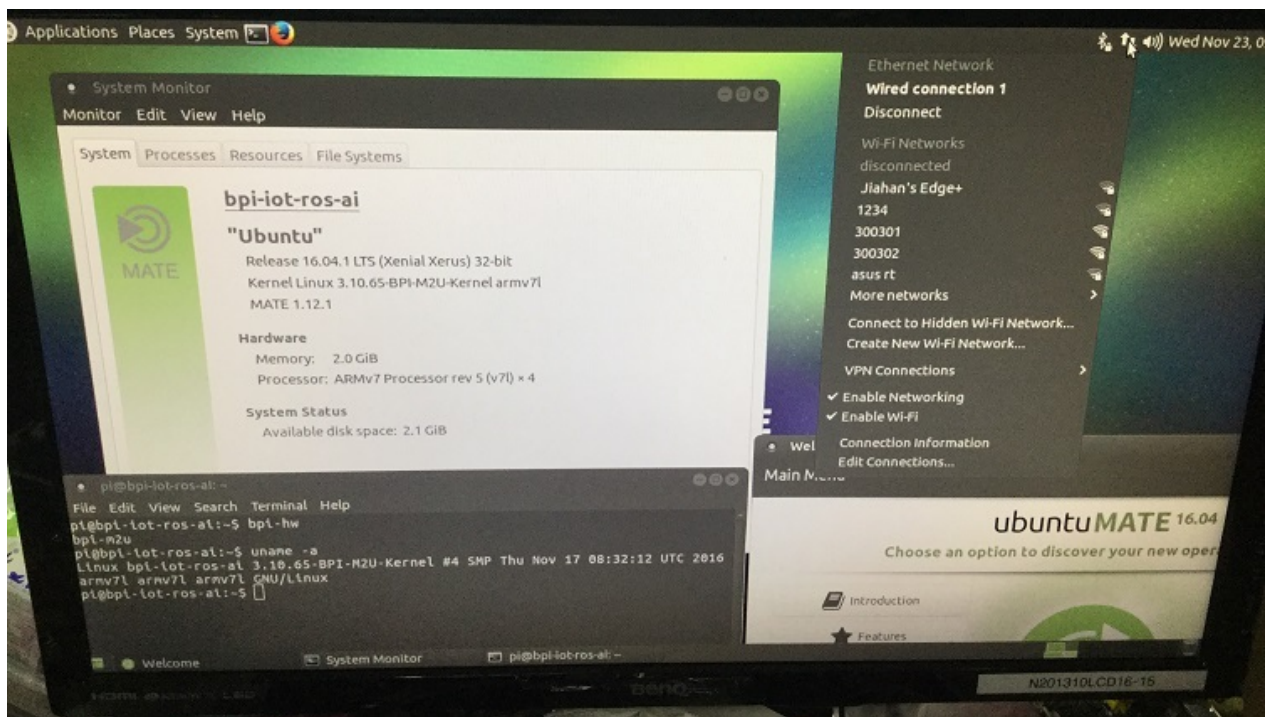

1. based on ubuntu 16.04.1 LTS Mate Desktop
2. BPI-M2U kernel 3.10.65
3. username & password: pi/bananapi , root/bananapi
4. support LCD 7"
5. support HDMI 1080P & 480P & 720P (default)
6. support GMAC
7. support WIFI
8. support BT (with bluetoothctl can setup)
9. support SATA
10. support eMMC (support boot from eMMC)
11. support Battery
12. support IR (getevent can test)
13. support touch screen (can control desktop or getevent to test) 13 support power key (getevent can test)
14. support OTG & adb (default on)
15. support CAMERA ov5640 (tinacameratest app support photo / video H.264 hw encode)
16. support uEnv.txt to fatload ulmage
17. support bpi-bootsel to set LCD7 or HDMI (720P & 1080P & 480P)
18. support bpi-copy to write SD/eMMC with img.zip file
19. support video play 1080p with vdpau (mpv)
20. support nodejs
21. support node-red

Google Drive:

https://drive.google.com/file/d/0B_YnvHgh2rwjUWZHd0k3SUI5Mmc/view?usp=sharing

baidu cloud:

<https://pan.baidu.com/s/1pK7nu3p>

MD5: f75fc192b51a438f613445f7482268e7

FILESIZE: 2024712263 (~1931MB)

UNPACK: 7456MB (eMMC size)

discuss on forum:

<http://forum.banana-pi.org/t/bpi-m2-ultra-new-image-ubuntu-16-04-1-mate-desktop-preview3-bpi-m2u-sd-emmc-img-2016-11-29/2498>

BPI-M2 Ultra new image : busybox-adbd-

camera-bpi-m2u.img 2016-10-01

2016-10-01-busybox-adbd-camera-bpi-m2u.img.zip

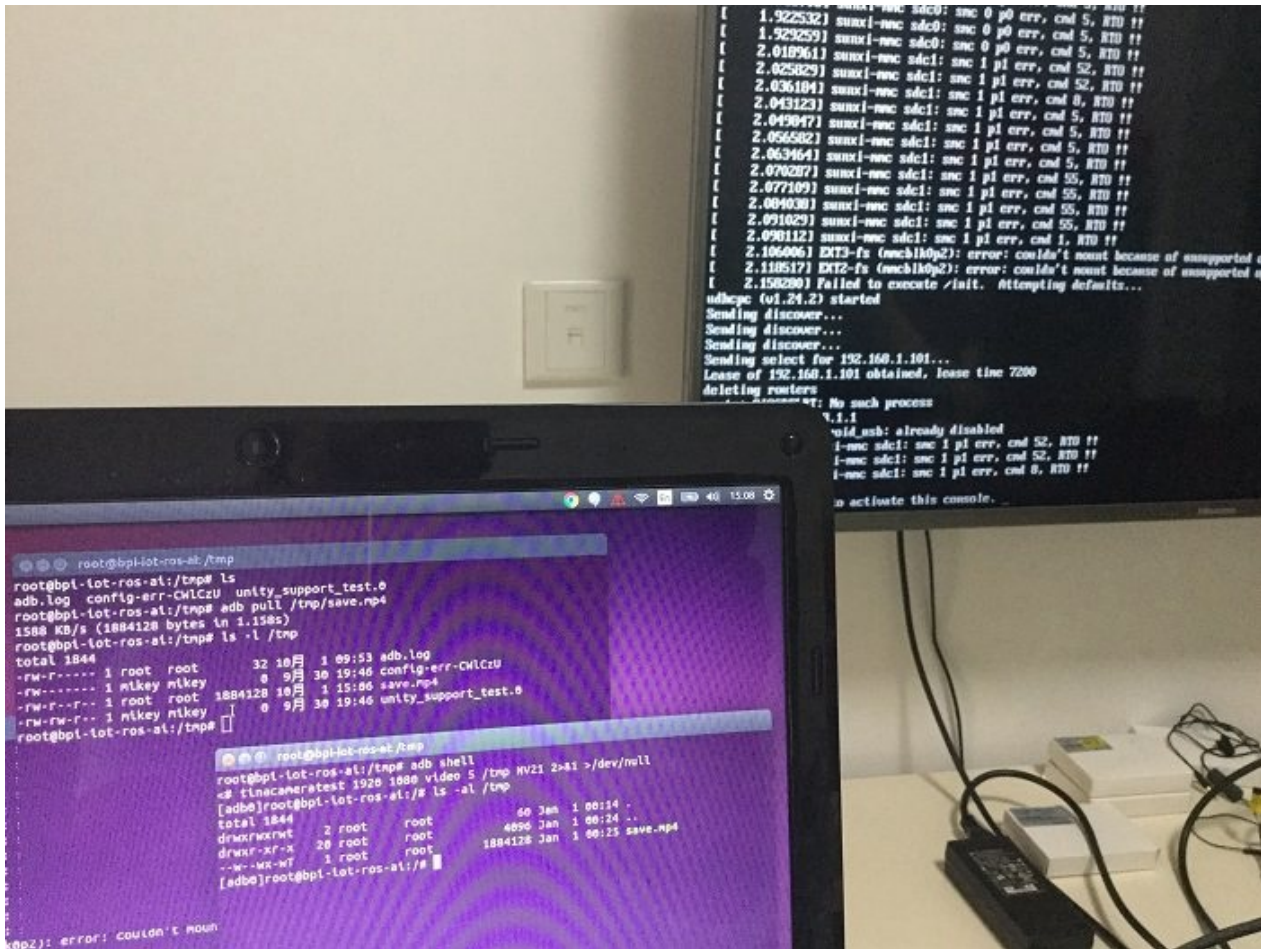

1. based on busybox v1.24.2 & bash-4.4-rc1
2. BPI-M2U kernel 3.10.65
3. username & password: pi/bananapi , root/bananapi
4. support HDMI 1080P & 720P(default)
5. support GMAC
6. support WIFI (bcmhdhd module only)
7. support SATA
8. support battery
9. support uEnv.txt to fatload ulmage
10. support uEnv.txt to set video 1080P & 720P & 480P ...
11. support camera (tinacameratest app support photo / video H.264 hw encode)
12. support otg & adbd (default on)
13. support telnetd
14. Thanks to busybox (<https://busybox.net/>)
15. Thanks to gnu.org (<http://www.gnu.org/software/bash/>)

baidu cloud:

<https://pan.baidu.com/s/1dFJqjpn>

MD5: c49012622909ef8a06fa9f893529accd

ZIP IMAGE SIZE: 19855063(~19MB)

SD SIZE: needed >=200MB

discuss on forum:

<http://forum.banana-pi.org/t/bpi-m2-ultra-new-image-busybox-adbd-camera-bpi-m2u-img-2016-10-01/2302>

BPI-M2 Ultra new image:ubuntu-16.04-xenial-minimal-preview-bpi-m2u.img 2016-09-29

2016-09-29-ubuntu-16.04-xenial-minimal-preview-bpi-m2u.img.zip

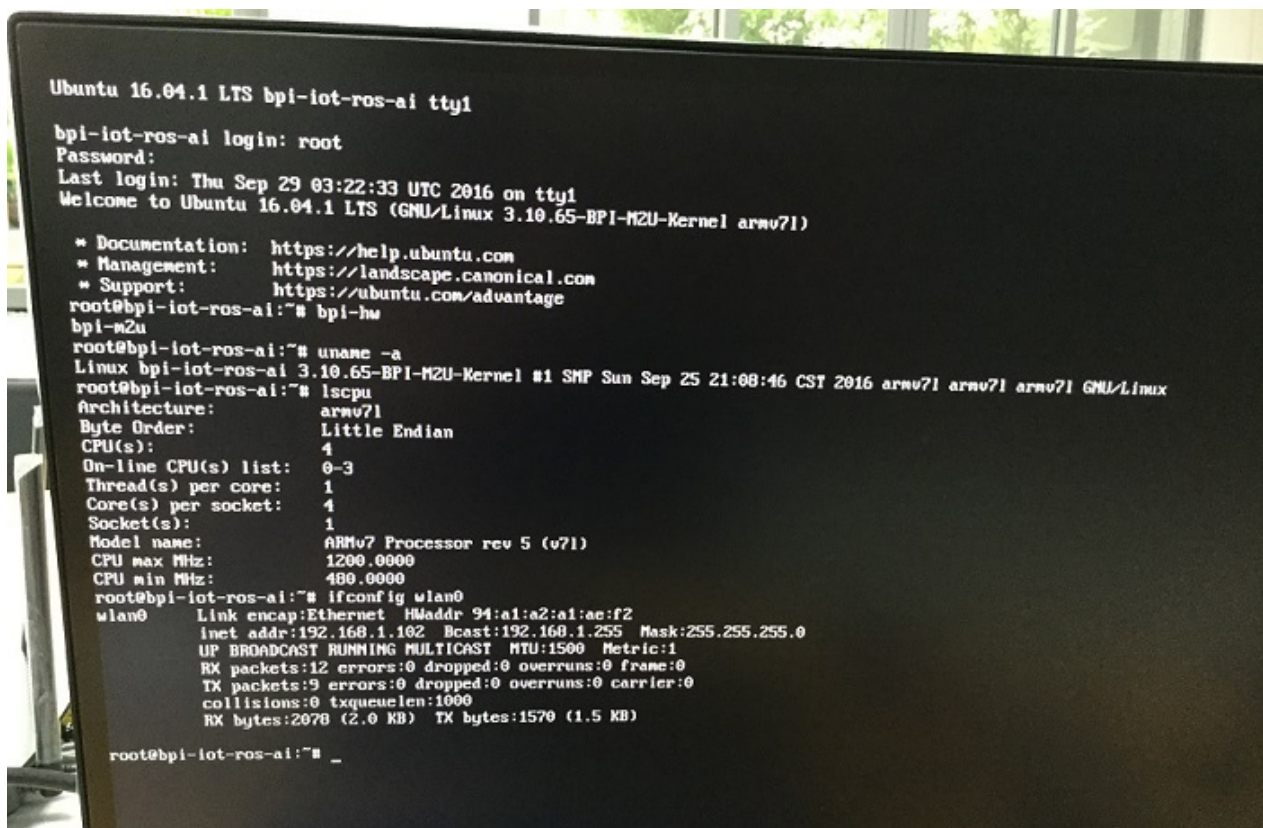

1. based on ubuntu 16.04.1 LTS
2. BPI-M2U kernel 3.10.65
3. username & password: pi/bananapi , root/bananapi
4. support HDMI 1080P & 720P(default)

5. support GMAC
6. support WIFI (modify /etc/network/interfaces.d/wlan0 for auto connect)
7. support SATA
8. support battery
9. support uEnv.txt to fatload ulmage
10. support uEnv.txt to set video 1080P & 720P & 480P ...
11. support camera (tinacameratest app support photo / video H.264 hw encode)
12. support otg & adbd (default on)
13. support LCD (bpi-bootsel to set LCD or 720P & 1080P)
14. Thanks to ubuntu (<http://www.ubuntu.com>)

image file size just about 200M.

Google Drive:

https://drive.google.com/file/d/0B_YnvHgh2rwjUURtdW5tbTdtT28/view?usp=sharing

MD5: e83e94dc1f9d9e35efdaa0b3f74694cd

discuss on forum:

<http://forum.banana-pi.org/t/bpi-m2-ultra-new-image-ubuntu-16-04-xenial-minimal-preview-bpi-m2u-img-2016-09-29/2300>

BPI-M2 Ultra new image:debian-8-jessie-mate-demo-bpi-m2u.img 2016-09-28

2016-09-28-debian-8-jessie-mate-demo-bpi-m2u.img.zip

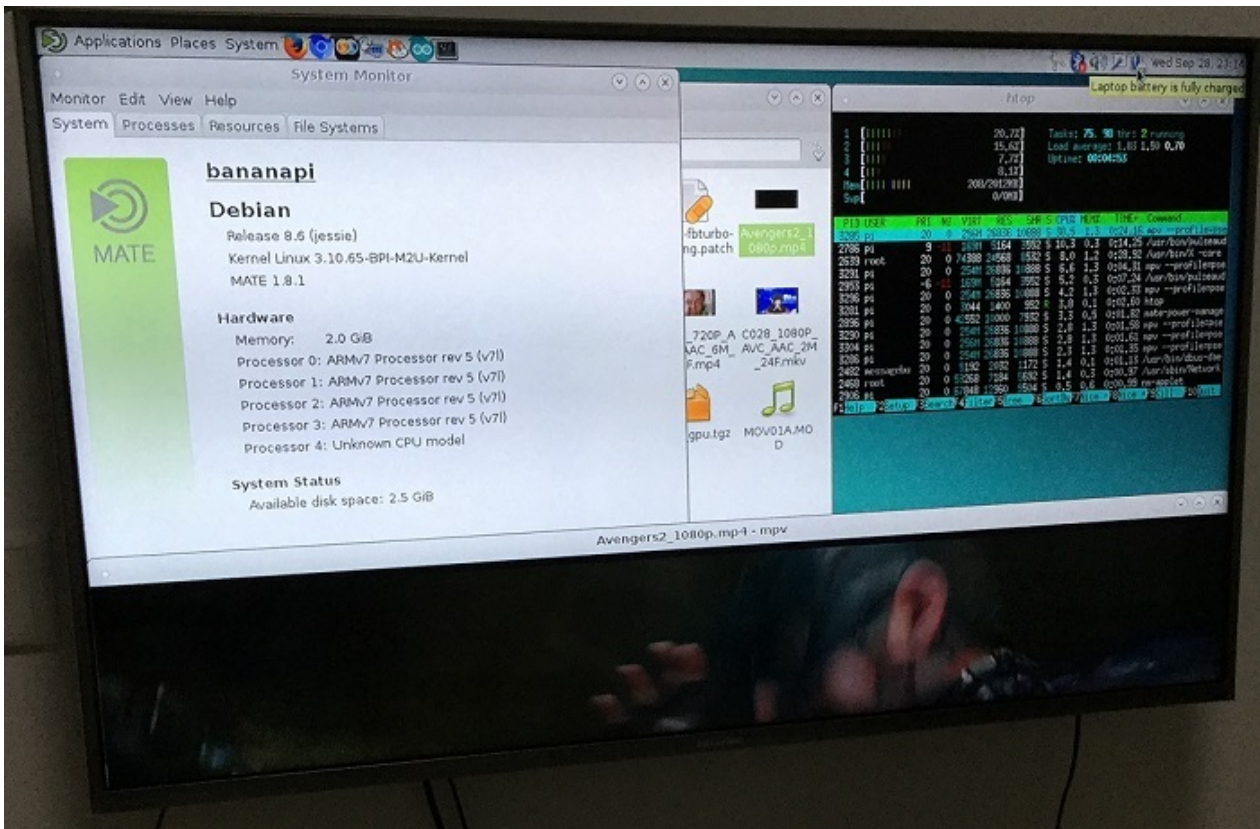

1. based on debian 8.6 with mate desktop
2. BPI-M2U kernel 3.10.65
3. username & password: pi/bananapi , root/bananapi
4. support HDMI 1080P & 720P(default)
5. support GMAC
6. support WIFI
7. support SATA
8. support battery
9. support uEnv.txt to fatload ulmage
10. support uEnv.txt to set video 1080P & 720P & 480P ...
11. support camera (tinacameratest app support photo / video H.264 hw encode)
12. support video play 1080p with vdpau (mpv)
13. support otg & adbd (default on)
14. support LCD (bpi-bootsel to set LCD or HDMI 720P & 1080P)
15. Thanks to debian.org (<http://www.debian.org>)
16. Thanks to mate-desktop.org (<http://mate-desktop.org/>)

Google Drive:

https://drive.google.com/file/d/0B_YnvHgh2rwjeEt5WnlXSEV1eEU/view?usp=sharing

MD5: 8d615b8adb5451fa702dd04e82c6659b

discuss on forum:

<http://forum.banana-pi.org/t/bpi-m2-ultra-new-image-debian-8-jessie-mate-demo-bpi-m2u-img-2016-09-28/2295>

BPI-M2 Ultra new image: debian-8-jessie-lite-preview-bpi-m2u.img 2016-09-27

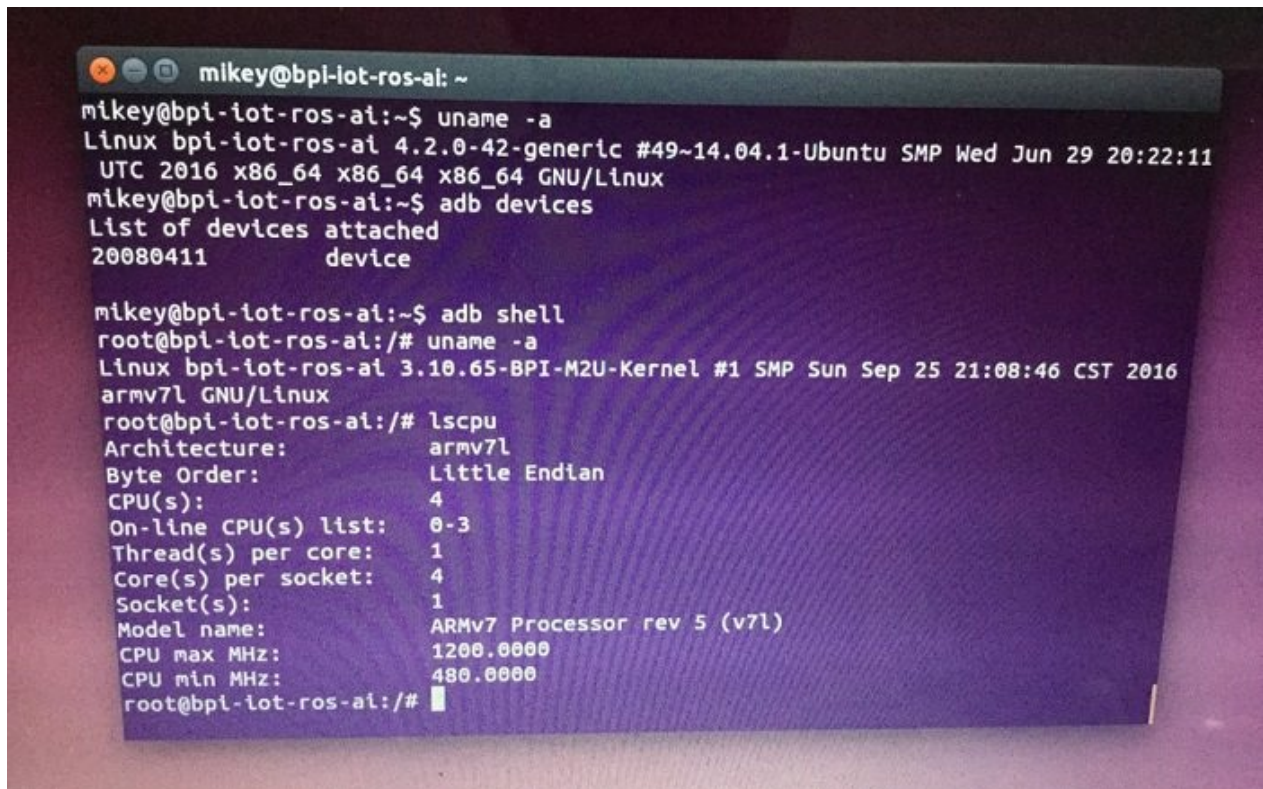

```
mikey@bpi-iot-ros-ai: ~
mikey@bpi-iot-ros-ai:~$ uname -a
Linux bpi-iot-ros-ai 4.2.0-42-generic #49~14.04.1-Ubuntu SMP Wed Jun 29 20:22:11
UTC 2016 x86_64 x86_64 x86_64 GNU/Linux
mikey@bpi-iot-ros-ai:~$ adb devices
List of devices attached
20080411          device

mikey@bpi-iot-ros-ai:~$ adb shell
root@bpi-iot-ros-ai:/# uname -a
Linux bpi-iot-ros-ai 3.10.65-BPI-M2U-Kernel #1 SMP Sun Sep 25 21:08:46 CST 2016
armv7l GNU/Linux
root@bpi-iot-ros-ai:/# lscpu
Architecture:        armv7l
Byte Order:          Little Endian
CPU(s):              4
On-line CPU(s) list: 0-3
Thread(s) per core: 1
Core(s) per socket: 4
Socket(s):           1
Model name:          ARMv7 Processor rev 5 (v7l)
CPU max MHz:         1200.0000
CPU min MHz:         480.0000
root@bpi-iot-ros-ai:/#
```

1. BPI-M2U kernel 3.10.65
2. username & password: pi/bananapi , root/bananapi
3. support HDMI 1080P & 720P(default)
4. support GMAC
5. support WIFI
6. support uEnv.txt to fatload ulmage
7. support uEnv.txt to set video 1080P & 720P & 480P ...
8. support camera (tinacameratest app support photo / video H.264 hw encode)
9. support otg & adbd (default on)
10. support LCD (bpi-bootsel to set LCD or 720P & 1080P)

Google Drive:

https://drive.google.com/file/d/0B_YnvHgh2rwjS0NXakYtS3VQQk0/view?usp=sharing

MD5: 88b9a65bbee799d68f6270028b0c839e

discuss on forum:

<http://forum.banana-pi.org/t/bpi-m2-ultra-new-image-debian-8-jessie-lite-preview-bpi-m2u-img-2016-09-27/2292>

BPI-M2 Ultra new image:ubuntu-mate-16.04-Xenial-edu-docker-demo-bpi-m2u.img 2016-9-26

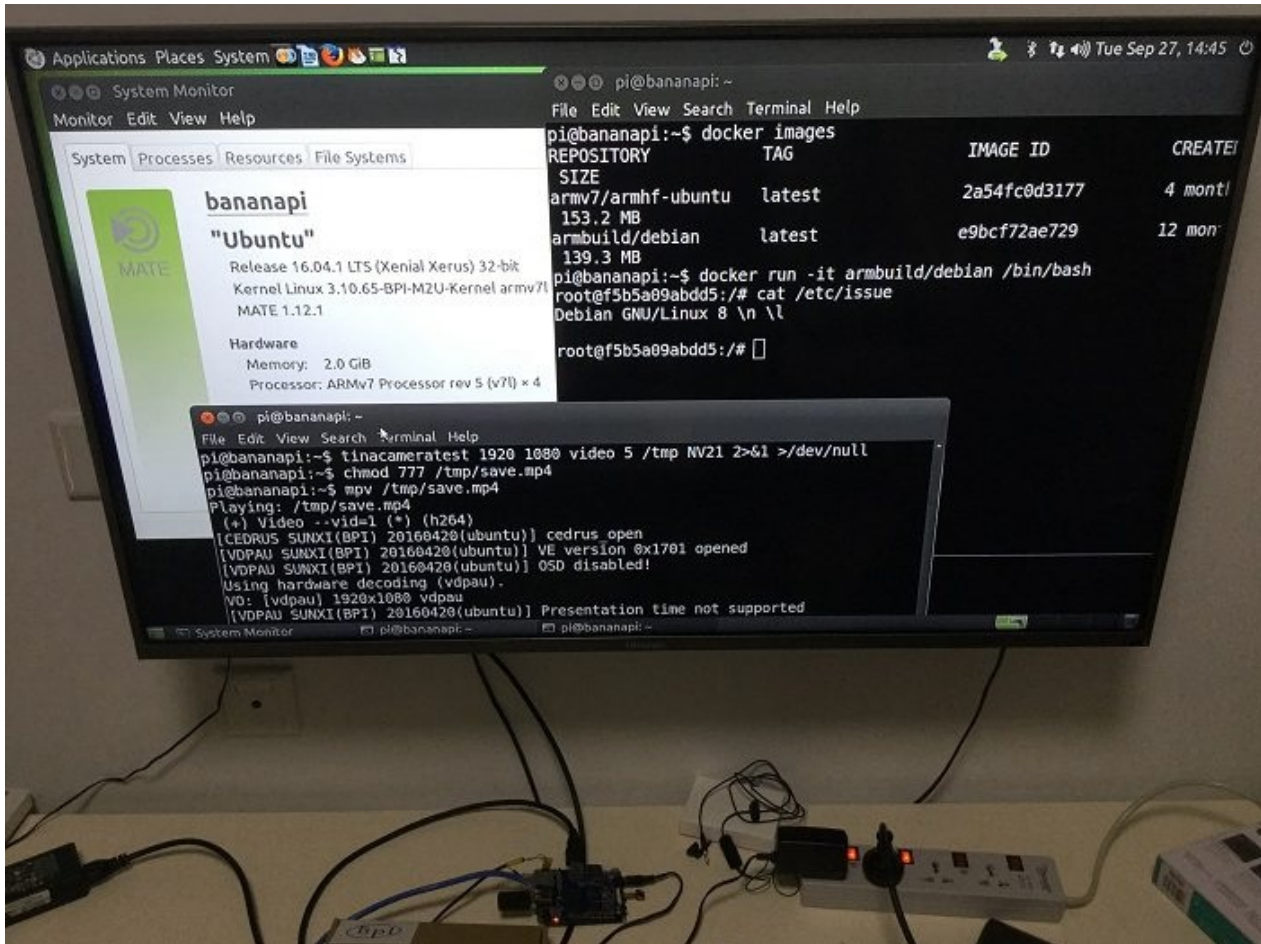

1. based on ubuntu 16.04 mate from bpi-m3-mate (<http://opensource.ntpc.edu.tw/>)
2. BPI-M2U kernel 3.10.65
3. username & password: pi/bananapi , root/bananapi
4. support HDMI 1080P & 720P(default)
5. support GMAC
6. support WIFI
7. support SATA
8. support uEnv.txt to fatload ulmage
9. support uEnv.txt to set video 1080P & 720P & 480P ...
10. support camera (tinacameratest app support photo / video H.264 hw encode)
11. support video play 1080p with vdpau (mpv, vlc, smplayer)

12. support docker (included ubuntu & debian image)
13. support nodejs
14. support node-red
15. included many apps for edu
16. support scratch 2 online with scratchx
17. special thanks to the team of <http://opensource.ntpc.edu.tw/>

info: need \geq 16GB SD and not use for eMMC(8GB)

Google Drive:

https://drive.google.com/file/d/0B_YnvHgh2rwjcUV5NnJkMi1wY3c/view?usp=sharing

MD5: 7c24c95a262edd8b7b5b7d70813c013a

discuss on forum:

<http://forum.banana-pi.org/t/bpi-m2-ultra-new-image-ubuntu-mate-16-04-xenial-edu-docker-demo-bpi-m2u-img-2016-9-26/2291>

Allwinner Tina-IoT os for BPI-M2 Ultra

About Tina-IoT Linux

Dear user for BPI-M2 Ultra R40 Tina Linux V1.0 have public , Come and try

Tina Linux development by Allwinner TinaTEAM, it base on OpenWrt, To build an embedded Linux distributions, The purpose of this release is to provide a quick learning and development is simple and convenient mass production Linux TurnKey solutions.

The release of R40 Tina Linux is base on BPI-M2 Ultra reference hardware, that is, the source code download directly support banana pi BPI-M2 Ultra.

R40 Tina Linux V1.0 version Base on Linux-3.10 and Tina Linux V2.1, it support a lot of fun and practical support functions:

- 1.support smartlink, (ultrasonic wave,airkiss,cooe)
- 2.support DLNA 、 QPlay Audio transmission and control protocol

Too much, not to speak one by one, in support of all hardware modules on BPI-M2 Ultra

How to use R40 Tina Linux

Play Tina need a 64 - bit Linux PC, we recommend using Ubuntu 12.04 or 14.04 64 - bit version, installed with the following command to install the build environment depends on:

```
sudo apt-get install build-essential subversion git-core libncurses5-dev zlib1g-dev gawk flex quilt libssl-dev xsltproc libxml-parser-perl mercurial bzip2 ecj cvs unzip
```

You can refer to detailed [OpenWrt's WIKI](#)

download source code

use repo tool to download this code , tool download method is as follows:

```
$ curl https://raw.githubusercontent.com/tinalinux/repo/stable/repo > ~/bin/repo
$ chmod +x ~/bin/repo
```

Then add "repo" to the environment variables, it is better to put the following sentences.

Bashrc inside

```
$ export PATH=~/bin:$PATH
```

Download the repo, the next download Tina's source code, as follows:

```
$ repo init -u https://github.com/tinalinux/manifest -b r40-v1.y -m r40/v1.y.xml
$ repo sync
$ repo start r40-v1.y --all
```

after downloading the source code, execute the following commands in Tina with directory compiled:

```
$ source build/envsetup.sh
$ lunch azalea_m2ultra-tina
$ make -j4
$ pack [-d]
```

Tina SDK need to perform "source "and "lunch" commond before every compile,Then perform other operations.

pack command has a "-d" parameter,The function of the parameter is: do not add - d use the default uart0 as a serial port output, added - d use TF bayonet IO mouth group as uart0

Burn image

Tina image Packaging has about 15 M, and support directly burned to eMMC flash on BPI-M2 Ultra.

Burning method is as follows:

if you use Linux system , Direct use LiveSuit for flash. Method of use is as follows:

- 1.LiveSuit we place it at tina SDK tools/aw_tools dir
- 2.unzip LiveSuit 64bit version , run./LiveSuit.sh
- 3.LiveSuit will install at ~/Bin dir , use dpkg -i install aw driver,driver also at ~/Bin dir.
- 4.run LiveSuit , choose tina image
- 5.Hold the BPI-M2 Ultra uboot key , insert the usb , you can begin burn image

if use Windows system ,plsase use burn tool : phoenixsuit

we place it at tools/aw_tools dir

How to configuration Tina

Tina firmware configuration, there are two commonly used commands:"make menuconfig" and "make kernel_menuconfig".

These two commands must be in execution after "source " and "lunch" command run finished ,

make menuconfig : Which software is used to configure the system use

make kernel_menuconfig:Used to configure the kernel options.

TinaLinux source code on github:

<https://github.com/tinalinux/>

[bpi-tools]: v1.0.3: bpi-tools bpi-get cmd support update tools & download images

bpi-tools can install to X86 ubuntu and Banana Pi:

on x86 pc:

for ubuntu 14.04 (x86):

```
`dpkg --add-architecture armhf`
```

or for ubuntu 12.04 (x86):

```
`echo "foreign-architecture armhf" >> /etc/dpkg/dpkg.cfg.d/multiarch`  
  
`dpkg -i bananapi-bpi-tools*.deb`
```

if you don't have pv cmd:

```
`apt-get install pv (for bpi-copy use)`  
  
**download bpi-tools & install:**
```

on ubuntu / raspbian / debian :

download file: bananapi-bpi-tools_1.0.3_armhf.deb

github:

https://github.com/BPI-SINOVOIP/BPI-files/raw/master/debs/bananapi-bpi-tools_1.0.3_armhf.deb

google drive:

https://drive.google.com/file/d/0B_YnvHgh2rwjc29jNVdoaDNXRUU/view?usp=sharing

MD5: 0408a434003651001f0131e61cad2fd

```
`# sudo dpkg -i bananapi-bpi-tools_1.0.3_armhf.deb`
```

on other system :

download file: bpi-tools.tgz

google drive: https://drive.google.com/file/d/0B_YnvHgh2rwjMGZOZC1Gd3dwQkE/view?usp=sharing

MD5: 82e35dba52bc3edb48e96c8a544ac216

```
`# sudo tar xvf bpi-tools.tgz -C /`
```

HOW TO USE:

```
root@bananapi:~# bpi-tools
      bpi-tools v1.0.6
usage: bpi-tools
      bpi-tools FILE
      bpi-tools --all | --update | --download | --version
```

bpi files:

```
bpi-tools      v1.0.6
bpi-bootSEL    v1.0.4
bpi-copy       v1.0.10a
bpi-get        v1.0.3
```

```
root@bananapi:~# bpi-tools --update
```

```
      bpi-tools v1.0.6
usage: bpi-tools
      bpi-tools FILE
      bpi-tools --all | --update | --download | --version
```

BPIFILE=/root/.bpi-tools.lst

Wait for download index file ...

OK!!\n

bpi files:

```
bpi-tools      v1.0.6
bpi-bootSEL    v1.0.4
bpi-copy       v1.0.10a
bpi-get        v1.0.3
```

```
root@bananapi:~# bpi-tools --version
```

bpi files:

```
/usr/bin/bpi-tools  v1.0.6
/usr/bin/bpi-bootSEL v1.0.4
/usr/bin/bpi-copy   v1.0.10a
/usr/bin/bpi-get    v1.0.3
```

```
root@bananapi:~# bpi-tools --download
```

download bpi files:

```
bpi-tools
bpi-tools: OK
bpi-tools: v1.0.6
bpi-bootSEL
bpi-bootSEL: OK
bpi-bootSEL: v1.0.4
bpi-copy
bpi-copy: OK
```



```

bpi-copy: v1.0.10a
bpi-get
bpi-get: OK
bpi-get: v1.0.3
root@bananapi:~# ls -l
total 20
-rwxr-xr-x 1 root root 1493  5月  6 10:06 bpi-bootsel
-rwxr-xr-x 1 root root 6170  5月  6 10:06 bpi-copy
-rwxr-xr-x 1 root root 1391  5月  6 10:06 bpi-get
-rwxr-xr-x 1 root root 2898  5月  6 10:06 bpi-tools
root@bananapi:~# bpi-get
      bpi-get v1.0.3
usage: bpi-get
      bpi-get FILE

BPIFILE=/root/.bpi-files.lst

```

Wait for download index file ...

```

bpi files:
2016-05-05-u1510_gpu_vpu_camera_bt_bpi-m2p_beta.img.zip
2016-05-05-debian-8-jessie-lite-bpi-m2p_beta-sd-emmc.img.zip
2016-04-27-debian-8-jessie-mate_gpu_mpv_1080p-bpi-m3_beta-sd-emmc.img.zip
2016-04-25-ubuntu-mate-16.04_Xenial_gpu_mpv_1080p_bt-bpi-m3_beta-sd-emmc.img.zip
u1510_gpu_vpu_camera_bpi-m2p-20160413_preview.img.zip
2016-04-11-Armbian_5.07-Bananapim2plus_Debian_jessie_3.4.111_desktop_preview.img.zip
p
2016-04-08-raspbian-jessie-bpi-m2.img.zip
2016-04-08-raspbian-jessie-bpi-m2p.img.zip
2016-04-08-raspbian-jessie-bpi-m3.img.zip

```

```

root@bananapi:~# bpi-get 2016-05-05-debian-8-jessie-lite-bpi-m2p_beta-sd-emmc.img.
zip
INFO: Try to get 2016-05-05-debian-8-jessie-lite-bpi-m2p_beta-sd-emmc.img.zip ...
BPIFILE=/root/.bpi-files.lst
IMGFILE=2016-05-05-debian-8-jessie-lite-bpi-m2p_beta-sd-emmc.img.zip
MD5TMP=/tmp/.md5.tmp.8322
  % Total    % Received % Xferd  Average Speed   Time    Time     Time  Current
             Dload  Upload  Total   Spent    Left     Speed
100 280    0 280    0    0    430    0  --:--:--  --:--:--  --:--:--   430
  0    0    0 671M    0    0 3317k    0  --:--:--  0:03:27  --:--:-- 3533k
2016-05-05-debian-8-jessie-lite-bpi-m2p_beta-sd-emmc.img.zip: OK
root@bananapi:~# bpi-copy .
SRC=.
DST=
COPYMODE=usage
default
      bpi-copy v1.0.10a
usage: bpi-copy
      bpi-copy IMGFILE

```

```

bpi-copy IMGDIR
bpi-copy IMGFILE DEVICE
bpi-copy DEVICE IMGFILE

bpi images: (*.img.zip)
./2016-05-05-debian-8-jessie-lite-bpi-m2p_beta-sd-emmc.img.zip
bpi images: (*.img)
bpi images: (*.img.gz)
/usr/lib/u-boot/bananapi/bpi-m2/BPI_M2_720P.img.gz
/usr/lib/u-boot/bananapi/bpi-m2p/BPI_M2P_720P.img.gz
/usr/lib/u-boot/bananapi/bpi-m3/BPI_M3_720P.img.gz
/usr/lib/u-boot/bananapi/u-boot-2016.05-rc1/u-boot-2016.05-rc1-bpi-m1.img.gz
/usr/lib/u-boot/bananapi/u-boot-2016.05-rc1/u-boot-2016.05-rc1-bpi-m1p.img.gz
/usr/lib/u-boot/bananapi/u-boot-2016.05-rc1/u-boot-2016.05-rc1-bpi-m2.img.gz
/usr/lib/u-boot/bananapi/u-boot-2016.05-rc1/u-boot-2016.05-rc1-bpi-m2p.img.gz
/usr/lib/u-boot/bananapi/u-boot-2016.05-rc1/u-boot-2016.05-rc1-bpi-m3.img.gz
/usr/lib/u-boot/bananapi/u-boot-2016.05-rc1/u-boot-2016.05-rc1-bpi-r1.img.gz
xz images: (*.xz)
zip images: (*.zip)
./2016-05-05-debian-8-jessie-lite-bpi-m2p_beta-sd-emmc.img.zip
raw images: (*.raw)

Disks: (lsblk | grep disk)
sda      8:0    0 931.5G 0 disk
sdb      8:16   0  2.7T  0 disk
sdc      8:32   1 14.9G  0 disk

Disks: (fdisk -l | grep Disk | grep bytes)
Disk /dev/sda: 1000.2 GB, 1000204886016 bytes
Disk /dev/sdb: 3000.6 GB, 3000558944256 bytes
Disk /dev/sdc: 15.9 GB, 15931539456 bytes
root@bananapi:~# bpi-copy ./2016-05-05-debian-8-jessie-lite-bpi-m2p_beta-sd-emmc.i
mg.zip /dev/sdc
SRC=./2016-05-05-debian-8-jessie-lite-bpi-m2p_beta-sd-emmc.img.zip
DST=/dev/sdc
COPYMODE=imagetodisk
imagetodisk
    bpi-copy v1.0.10a
usage: bpi-copy
    bpi-copy IMGFILE
    bpi-copy IMGDIR
    bpi-copy IMGFILE DEVICE
    bpi-copy DEVICE IMGFILE

Warning: Try to write ./2016-05-05-debian-8-jessie-lite-bpi-m2p_beta-sd-emmc.img.z
ip to BOOTDISK /dev/sdc
=====
五  5月  6 10:21:13 CST 2016
*** start COPY (blue led on ) .....
umount device: /dev/sdc
umount /dev/sdc2
umount /dev/sdc1
=====

```

```

IMGFILE=./2016-05-05-debian-8-jessie-lite-bpi-m2p_beta-sd-emmc.img.zip
=====
zip
1.91GB 0:01:59 [16.3MB/s] [ <=> ]
0+20666 records in
0+20666 records out
*** end COPY (blue led off) .....
五 5月 6 10:23:40 CST 2016
=====
RUNTIME 2:27
OK!! You can remove the BOOTDISK /dev/sdc now!!
root@bananapi:~#

```

if you want to use bpi-m2p image for bpi-m3, you can re-insert SD card:

```

root@bananapi:~# bpi-bootset
    bpi-bootset v1.0.4
usage: bpi-bootset
    bpi-bootset IMGFILE
    bpi-bootset IMGFILE DEVICE

bpi images:
/usr/lib/u-boot/bananapi/u-boot-2016.05-rc1/u-boot-2016.05-rc1-bpi-m1.img.gz
/usr/lib/u-boot/bananapi/u-boot-2016.05-rc1/u-boot-2016.05-rc1-bpi-m2.img.gz
/usr/lib/u-boot/bananapi/u-boot-2016.05-rc1/u-boot-2016.05-rc1-bpi-m1p.img.gz
/usr/lib/u-boot/bananapi/u-boot-2016.05-rc1/u-boot-2016.05-rc1-bpi-m2p.img.gz
/usr/lib/u-boot/bananapi/u-boot-2016.05-rc1/u-boot-2016.05-rc1-bpi-r1.img.gz
/usr/lib/u-boot/bananapi/u-boot-2016.05-rc1/u-boot-2016.05-rc1-bpi-m3.img.gz
/usr/lib/u-boot/bananapi/bpi-m2/BPI_M2_720P.img.gz
/usr/lib/u-boot/bananapi/bpi-m2p/BPI_M2P_720P.img.gz
/usr/lib/u-boot/bananapi/bpi-m3/BPI_M3_720P.img.gz

Disks: (lsblk | grep disk)
sda      8:0    0 931.5G 0 disk
sdb      8:16   0  2.7T  0 disk
sdc      8:32   1 14.9G  0 disk

Disks: (fdisk -l | grep Disk | grep bytes)
Disk /dev/sda: 1000.2 GB, 1000204886016 bytes
Disk /dev/sdb: 3000.6 GB, 3000558944256 bytes
Disk /dev/sdc: 15.9 GB, 15931539456 bytes
root@bananapi:~# bpi-bootset /usr/lib/u-boot/bananapi/bpi-m3/BPI_M3_720P.img.gz /dev/sdc
Warning: Try to write /usr/lib/u-boot/bananapi/bpi-m3/BPI_M3_720P.img.gz to BOOTDISK /dev/sdc
umount device: /dev/sdc
umount /dev/sdc2
umount /dev/sdc1
OK!! You can remove the BOOTDISK /dev/sdc now!!
root@bananapi:~#

```

bpi-bootSEL commond

How to use bpi-bootSEL command (Multi-use SD card supported)

From now on, just download either M2 or M3, then you can switch to any of them as you wish!

bpi-bootSEL v1.0.5

```
usage: bpi-bootSEL
       bpi-bootSEL IMGFILE
       bpi-bootSEL IMGFILE DEVICE
```

1. Download BPI-Tools , please run the following command

```
wget https://github.com/BPI-SINOVOIP/BPI-files/raw/master/debs/bananapi-bpi-tools\_1.0.3\_armhf.deb
```

1. Set up development environment

2-1: On X86-PC (Ubunut 12.04)

```
sudo echo "foreign-architecture armhf" >> /etc/dpkg/dpkg.cfg.d/multiarch
```

2-2 :On X86-PC (Ubunut 14.04)

```
sudo dpkg --add-architecture armhf
```

2-3 :**On BananaPI M3/M2Plus do nothing**

2. Install BPI-Tools

```
sudo dpkg -i bananapi-bpi-tools*.deb
```

3. Creat a folder of BPI-Tools

```
mkdir BPI-Tools cd BPI-Tools
```

4. Update BPI-Tools

```
sudo bpi-tools --upgrade
```

5. Use bpi-bootSEL commnad

6-1: M3 imgae is switchable to M2_Plus

```
sudo bpi-bootSEL /usr/lib/u-boot/bananapi/bpi-m2p/BPI_M2P_720P.img.gz
```

6-2 : M2_Plus imgae is switchable to M3imgae

```
| sudo bpi-bootsel /usr/lib/u-boot/bananapi/bpi-m3/BPI_M3_720P.img.gz
```

Video Demo

<https://www.youtube.com/watch?v=HdBNcrOKngM&feature=youtu.be>

bpi-get command

How to use bpi-get command (Download BPI Images)

```
bpi-get v1.0.3
usage: bpi-get
       bpi-get FILE
```

1. Download BPI-Tools , please run the following command

```
wget https://github.com/BPI-SINOVOIP/BPI-files/raw/master/debs/bananapi-bpi-tools\_1.0.3\_armhf.deb
```

1. Set up development environment

2-1: On X86-PC (Ubunut 12.04)

```
sudo echo "foreign-architecture armhf" >> /etc/dpkg/dpkg.cfg.d/multiarch
```

2-2 :On X86-PC (Ubunut 14.04)

```
sudo dpkg --add-architecture armhf
```

2-3 :**On BananaPI M3/M2Plus do nothing**

2. Install BPI-Tools

```
sudo dpkg -i bananapi-bpi-tools*.deb
```

3. Creat a folder of BPI-Tools

```
mkdir BPI-Tools cd BPI-Tools
```

4. Update BPI-Tools

```
sudo bpi-tools --upgrade
```

5. Use bpi-get commnad

6-1: Download BPI Images

```
sudo bpi-get 2016-07-01-ubuntu-mate-16.04-Xenial-gpu-mpv-bt-nodejs-beta3-bpi-m3-sd-emmc.img.zip
```

Video Demo

<https://www.youtube.com/watch?v=Bf4QfDnwKAK&feature=youtu.be>

bpi-copy command

```
usage: bpi-copy  
bpi-copy IMGFILE  
bpi-copy IMGDIR  
bpi-copy IMGFILE DEVICE  
bpi-copy DEVICE IMGFILE
```

1. Download BPI-Tools , please run the following command

```
wget https://github.com/BPI-SINOVOIP/BPI-files/raw/master/debs/bananapi-bpi-tools\_1.0.3\_armhf.deb
```

1. Set up development environment

2-1: On X86-PC (Ubunut 12.04)

```
sudo echo "foreign-architecture armhf" >> /etc/dpkg/dpkg.cfg.d/multiarch
```

2-2 :On X86-PC (Ubunut 14.04)

```
sudo dpkg --add-architecture armhf
```

2-3 :**On BananaPI M3/M2Plus do nothing**

2. Install BPI-Tools

```
sudo dpkg -i bananapi-bpi-tools*.deb
```

3. Creat a folder of BPI-Tools

```
mkdir BPI-Tools cd BPI-Tools
```

4. Update BPI-Tools

```
sudo bpi-tools --upgrade
```

5. Use bpi-copy commnad

6-1: To burn into EMMC, please run the following command

```
sudo bpi-copy < images file>
```

6-2 :Copy data from SD-Card/EMMC to be Images

```
sudo bpi-copy < device path> < xxxxx.img.zip>
```

6-3 :To burn into certain device,please run the following command

```
sudo bpi-copy < xxxxx.img.zip> < device path>
```

Video Demo (To burn into EMMC)

<https://www.youtube.com/watch?v=Arn7HC2urt4>

Video Demo (Copy data from SD-Card/EMMC to be Images)

<https://www.youtube.com/watch?v=H1LjORwzO3E>

bpi-update command

How to : Use bpi-update command to update kernel image

Step1: Update bpi-tools

```
$ git clone https://github.com/BPI-SINOVOIP/bpi-tools.git8
$ cd bpi-tools
$ sudo ./bpi-tools -u -U
```

Step 2: Check bpi-tools version

```
$ bpi-tools -v
```

Step 3: Use bpi-update to update kernel

```
$ mkdir update_file
$ cd update_file
```

BPI-M2U

```
$ sudo bpi-update -c bpi-m2u.conf
```

BPI-M2P

```
$ sudo bpi-update -c bpi-m2p.conf
```

BPI-M3

```
$ sudo bpi-update -c bpi-m3.conf
```

BPI-M2 Ultra WiringPi

BPI WiringPi support all raspberry pi module and all banana pi module :BPI-M1,BPI-M1+,BPI-R1,BPI-M2,BPI-M2+,BPI-M2 Ultra,BPI-M2 Magic,BPI-M3,BPI-M64

<https://github.com/BPI-SINOVOIP/WiringPi>

<https://github.com/BPI-SINOVOIP/WiringPi/tree/master/wiringPi/board>

BPI-M2 Ultra source code on github

BPI-SINOVOIP / **BPI-M2U-bsp** Watch 2 Star 1 Fork 0

[Code](#) [Issues 0](#) [Pull requests 0](#) [Projects 0](#) [Pulse](#) [Graphs](#)

Supports Banana Pi BPI-M2 Ultra (R40) (Kernel3.10)

12 commits 1 branch 0 releases 1 contributor

Branch: **master** [New pull request](#) [Find file](#) [Clone or download](#)

File/Folder	Commit Message	Commit Date
BPI-SINOVOIP	enable emmc	Latest commit 7fb9911 3 days ago
lichee	init kernel 3.10: sync to Tina SDK 20161011	12 days ago
linux-sunxi	enable emmc	3 days ago
out	init kernel 3.10: sync to Tina SDK 20161011	12 days ago
scripts	support cmd: ./build.sh all to auto build for docker build env.	8 days ago
sunxi-pack/allwinner	enable LCD7 touch	7 days ago
u-boot-sunxi	enable emmc	3 days ago
Makefile	init kernel 3.10: sync to Tina SDK 20161011	12 days ago
README.md	Initial commit	12 days ago
build.sh	support cmd: ./build.sh all to auto build for docker build env.	8 days ago
configure	update build env. for SD image create with bpi-tools & bpi-migrate	12 days ago
target	init kernel 3.10: sync to Tina SDK 20161011	12 days ago

BPI official github:

<https://github.com/BPI-SINOVOIP/BPI-M2U-bsp>

Other github for BPI-M2 Ultra /Berry

<https://github.com/facat/BPI-M2U-bsp>

Supports Banana Pi BPI-M2 Ultra (R40) (Kernel3.10)

Banana Pi BPI-M2 Ultra / BPI-M2 Berry How to alter Uboot \ Kernel

1,Click <http://www.banana-pi.org/download.html>, download relatively BPI-M2 Ultra Image ; and burn images to SD card.

2,Install tool-chain

```
sudo apt-get install build-essential libncurses5-dev u-boot-tools qemu-user-static
debootstrap git binfmt-support libusb-1.0-0-dev pkg-config gcc-arm-linux-gnueabi g++-arm-
linux-gnueabi gcc-arm-linux-gnueabi g++-arm-linux-gnueabi libssl-dev
```

3,Install BPI-Tools ,to BPI-GitHub <https://github.com/BPI-SINOVOIP/bpi-tools>

```
git clone https://github.com/BPI-SINOVOIP/BPI-M2U-bsp.git
```

BPI-SINOVOIP / **bpi-tools** Watch 1 Star 1 Fork 0

[Code](#) [Issues 0](#) [Pull requests 0](#) [Projects 0](#) [Pulse](#) [Graphs](#)

tools for Banana Pi

5 commits 1 branch 0 releases 1 contributor

Branch: **master** [New pull request](#) [Find file](#) [Clone or download](#)

File	Commit Message	Time
README.md	Initial commit	a month ago
bpi-bootset	unpack from BPI-files/SD/BPI-ROOT/bpi-tools.tgz	a month ago
bpi-copy	unpack from BPI-files/SD/BPI-ROOT/bpi-tools.tgz	a month ago
bpi-get	move index files from google drive to github	a month ago
bpi-hw	unpack from BPI-files/SD/BPI-ROOT/bpi-tools.tgz	a month ago
bpi-migrate	fix bug: can not use -u -G for update & upgrade. and without -c that ...	11 days ago
bpi-tools	move index files from google drive to github	a month ago

4 , Put Download done BPI-Tools copy to under /usr/bin

```
sudo cp -a bpi-* /usr/bin/
```

```
justin@justin-OptiPlex-3010:~/BPI_Tools/bpi-tools$ sudo cp -a bpi-* /usr/bin/
```

Execute bpi-tools -u order , install successfully after appear belows screen

```

justin@justin-OptiPlex-3010:/$ bpi-tools -u
F_UPDATE=yes
BPIFILE=/home/justin/.bpi-tools.lst
Wait for download index file ...
OK!!\n

bpi files:
bpi-tools          v1.2.0(github)
bpi-bootset       v1.0.5
bpi-copy          v1.0.10a
bpi-get           v1.0.3(github)
bpi-migrate       v1.3.0(github)
bpi-hw           v1.2.8

```

Go to BPI-GitHub <https://github.com/BPI-SINOVOIP/BPI-M2U-bsp>

· note: BPI-M2 berry and BPI-M2 Ultra use the same code.

BPI-SINOVOIP / BPI-M2U-bsp

Watch 2 Star 1 Fork 0

Code Issues 0 Pull requests 0 Projects 0 Pulse Graphs

Supports Banana Pi BPI-M2 Ultra (R40) (Kernel3.10)

12 commits 1 branch 0 releases 1 contributor

Branch: master New pull request Find file Clone or download

File/Folder	Description	Latest commit	Time ago
BPI-SINOVOIP	enable emmc	7fb9911	3 days ago
lichee	init kernel 3.10: sync to Tina SDK 20161011		12 days ago
linux-sunxi	enable emmc		3 days ago
out	init kernel 3.10: sync to Tina SDK 20161011		12 days ago
scripts	support cmd: ./build.sh all to auto build for docker build env.		8 days ago
sunxi-pack/allwinner	enable LCD7 touch		7 days ago
u-boot-sunxi	enable emmc		3 days ago
Makefile	init kernel 3.10: sync to Tina SDK 20161011		12 days ago
README.md	Initial commit		12 days ago
build.sh	support cmd: ./build.sh all to auto build for docker build env.		8 days ago
configure	update build env. for SD image create with bpi-tools & bpi-migrate		12 days ago
target	init kernel 3.10: sync to Tina SDK 20161011		12 days ago

Grab BPI-M2Ultra-bsp Source Code; execute grabbing source code order

```
git clone https://github.com/BPI-SINOVOIP/BPI-M2U-bsp.git
```

```
justin@justin-OptiPlex-3010:/media/DATA_1/Temp_Github/BPI-M2U-bsp$ git clone https://github.com/BPI-SINOVOIP/BPI-M2U-bsp.git
```

switch to BPI-M2U-bsp category after carried out · execute ./build.sh order

```
justin@justin-OptiPlex-3010:/media/DATA_1/Temp_Github/BPI-M2U-bsp/BPI-M2U-bsp$ ./build.sh
```

Can see BPI-M2 Ultra/BPI-M2 Berry configuration,choose BPI-M2U's resolution what you wanted.:default compile 720P :

```
justin@justin-OptiPlex-3010:/media/DATA_1/Temp_Github/BPI-M2U-bsp/BPI-M2U-bsp$ ./build.sh
NOTICE:
new build.sh default select BPI_M2U_720P and pack all boards
supported boards:
BPI_M2U_1080P
BPI_M2U_480P
BPI_M2U_720P
BPI_M2U_LCD7

BPI_M2U_720P configured. Now run `make`
This tool support following building mode(s):
-----
1. Build all, uboot and kernel and pack to download images.
2. Build uboot only.
3. Build kernel only.
4. kernel configure.
5. Pack the builds to target download image, this step must execute after u-boot,
   kernel and rootfs build out
6. update files for SD
7. Clean all build.
-----
Please choose a mode(1-7):
```

Choose mode what you need compile (advise choose 1 option first time compile)

5 , Compile done can seen under generate new SD folder BPI-M2U-bsp

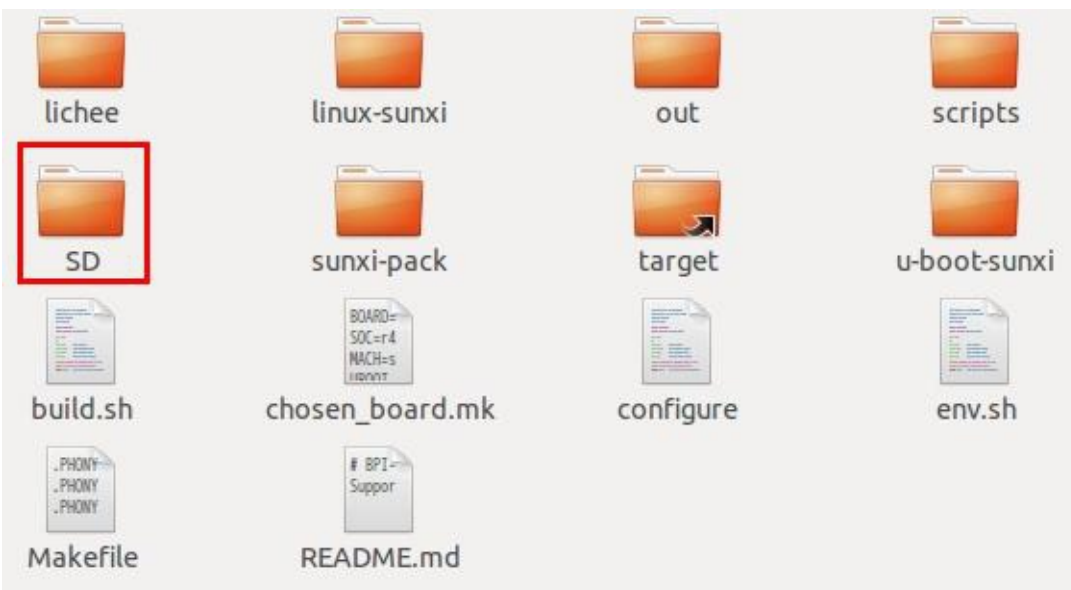

Later Enter into SD folder seen below files

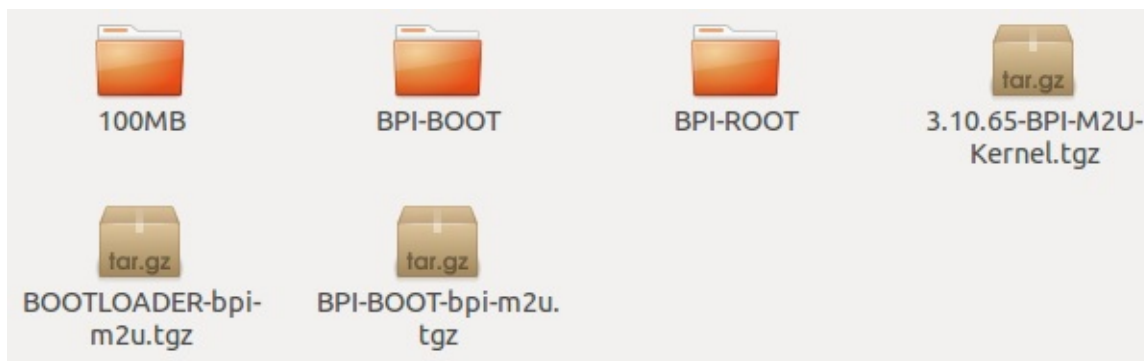

These files represent information one by one

100MB --> BPI-M2Ultra uboot relative file

BPI-BOOT-bpi-m2u.tgz --> BPI-M2Ultra uEnv.txt & ulmage relative file

3.10.65-BPI-M2U-Kernel.tgz --> BPI-M2Ultra kernel relative file

6,Use command to see the SD card current position.

```
sudo fdisk -l
```

```
Disk /dev/sdb: 7969 MB, 7969177600 bytes
246 heads, 62 sectors/track, 1020 cylinders, total 15564800 sectors
Units = sectors of 1 * 512 = 512 bytes
Sector size (logical/physical): 512 bytes / 512 bytes
I/O size (minimum/optimal): 512 bytes / 512 bytes
Disk identifier: 0x0007ab07

   Device Boot      Start         End      Blocks   Id  System
/dev/sdb1  *          204800       729087     262144    c   W95 FAT32 (LBA)
/dev/sdb2                729088     15269887    7270400   83   Linux
```

This example can be seen SD Card's position in /dev/sdb

Can be seen BPI-M2Ultra system has two partition,one FAT32 partition,another one EXT4 partition,represent gradually.

FAT32partition(/media/BPI-BOOT)	Mainly for uEnv.txt & ulmage
EXT4 partition (/media/BPI-ROOT)	Mainly for RootFS & kernel lib

7 , Change BPI-M2Ultra Uboot , switch to /SD/100MB category ; execute bpi-bootsetl order:

```
sudo bpi-bootsetl <file source> <SD route>
```

```
justin@justin-OptiPlex-3010:/media/DATA_1/Temp_Github/BPI-M2U-bsp/BPI-M2U-bsp/SD/100MB$ sudo bpi-bootsetl BPI_M2U_1080P.img.gz /dev/sdb
```

8 † Change BPI-M2Ultra ulmage ,switch to /SD/ category † carry out relative command.

```
sudo tar -xvf <file source> -C <SD Boot route >
```

```
justin@justin-OptiPlex-3010:/media/DATA_1/Temp_Github/BPI-M2U-bsp/BPI-M2U-bsp/SD$ sudo tar -xvf BPI-B00T-bpi-m2u.tgz -C /media/BPI-B00T
```

Below information after execute † successfully done.

```
justin@justin-OptiPlex-3010:/media/DATA_1/Temp_Github/BPI-M2U-bsp/BPI-M2U-bsp/SD$ sudo tar -xvf BPI-B00T-bpi-m2u.tgz -C /media/BPI-B00T
./
./bananapi/
./bananapi/bpi-m2u/
./bananapi/bpi-m2u/linux/
./bananapi/bpi-m2u/linux/uEnv.txt
./bananapi/bpi-m2u/linux/uImage
```

9 † Change BPI-M2Ultra Kernel † switch to /SD/ category † execute relative order

```
sudo tar -xvf <file source> -C <SD Boot route>
```

```
justin@justin-OptiPlex-3010:/media/DATA_1/Temp_Github/BPI-M2U-bsp/BPI-M2U-bsp/SD$ sudo tar -xvf 3.10.65-BPI-M2U-Kernel.tgz -C /media/BPI-R00T
```

Supplement

Change kernel setting † switch to / linux-sunxi category † execute order

```
make ARCH=arm menuconfig
```

```
justin@justin-OptiPlex-3010:/media/DATA_1/Temp_Github/BPI-M2U-bsp/BPI-M2U-bsp/li  
nux-sunxi$ make ARCH=arm menuconfig
```

```
.config - Linux/arm 3.10.65 Kernel Configuration
```

```
Linux/arm 3.10.65 Kernel Configuration  
Arrow keys navigate the menu. <Enter> selects submenus --->.  
Highlighted letters are hotkeys. Pressing <Y> includes, <N> excludes,  
<M> modularizes features. Press <Esc><Esc> to exit, <?> for Help, </>  
for Search. Legend: [*] built-in [ ] excluded <M> module < >
```

```
[*] Patch physical to virtual translations at runtime
```

```
General setup --->
```

```
[*] Enable loadable module support --->
```

```
[*] Enable the block layer --->
```

```
System Type --->
```

```
Bus support --->
```

```
Kernel Features --->
```

```
Boot options --->
```

```
CPU Power Management --->
```

```
Floating point emulation --->
```

```
Userspace binary formats --->
```

```
Power management options --->
```

```
v(+)
```

```
<Select>
```

```
< Exit >
```

```
< Help >
```

```
< Save >
```

```
< Load >
```

How to boot from emmc with SD data

STEP 1. boot from SD

1a. `bpi-copy xxx.img.zip #burn to emmc ;`

1b. `bpi-bootsel BPI_M2U_720P-emmc.img.gz /dev/mmcblk1 #auto download from github and burn to emmc;`

1c. `bpi-bootsel BPI-cleanboot-8k.img.gz /dev/mmcblk0 #auto download from github and burn to SD;`

STEP 2. boot from emmc

2a. `poweroff`

2b. remove SD card

2c. `poweron`

2d. insert SD card

2e. `fdisk /dev/mmcblk1 and mkfs -t ext4 /dev/mmcblk1p1`

How to rebuild bootloader BPI_M2U_720P-emmc.img.gz

1. git clone

<https://github.com/BPI-SINOVOIP/BPI-M2U-bsp.git>

1. `cp -a BPI-M2U-bsp/linux-sunxi/arch/arm/boot/dts/sun8iw11p1emmc.dtsi BPI-M2U-bsp/linux-sunxi/arch/arm/boot/dts/sun8iw11p1.dtsi`
2. `cd BPI-M2U-bsp ; ./build.sh all`
3. `mv SD/100MB/BPI_M2U_720P.img.gz SD/100MB/BPI_M2U_720P-emmc.img.gz`

BPI-M2 Ultra/Berry TinaLinux github

<https://github.com/tinalinux/linux-3.10>

Reference documents

Allwinner R40 chip datasheet

Allwinner V40 datasheet:

<https://drive.google.com/file/d/0B4PAo2nW2KfneE54VzVOdHpITzA/view?usp=sharing>

Allwinner R40 datasheet:

<https://drive.google.com/file/d/0B4PAo2nW2KfnbVp2TmRMYUdPUGM/view?usp=sharing>

Allwinner R40 User Manual v1.0

https://github.com/tinalinux/docs/blob/r40-v1.y/Allwinner_R40_User_Manual_V1.0.pdf

axp221s PMU datasheet:

<https://drive.google.com/file/d/0B4PAo2nW2KfnM2pnT19zZW5qOTA/view?usp=sharing>

linux-sunxi document

Linux mainlining effort - linux-sunxi.org about allwinner chip:

http://linux-sunxi.org/Linux_mainlining_effort

linux-sunxi document R40:

<http://linux-sunxi.org/R40>

linux-sunxi document for BPI-M2 Ultra

http://linux-sunxi.org/Sinovoip_Banana_Pi_M2_Ultra

google driver forum :

<https://groups.google.com/forum/#!forum/linux-sunxi>

BPI-M2 Ultra quality guarantee

All the products Banana pi release go through strictly controlled process from developing,testing,manufacturing to certification.

We put quality first, users can mass produce their products using our boards directly, we've been dedicating to providing the most cost performance products.

BPI-M2 Ultra WIFI&BT4.0 Lab test

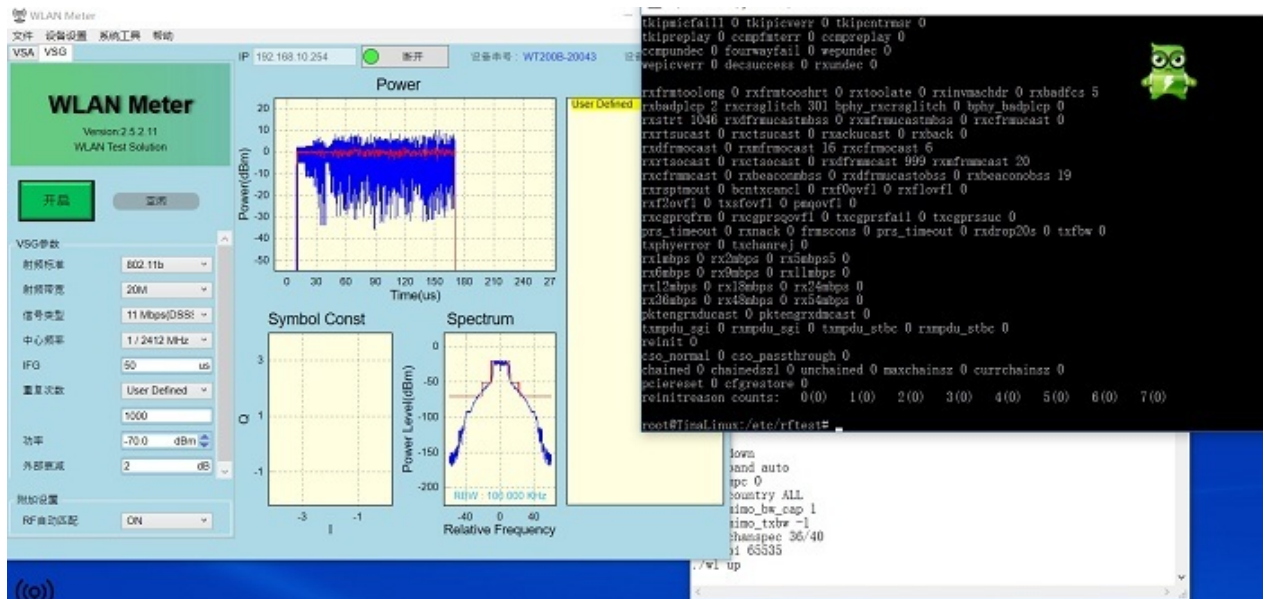
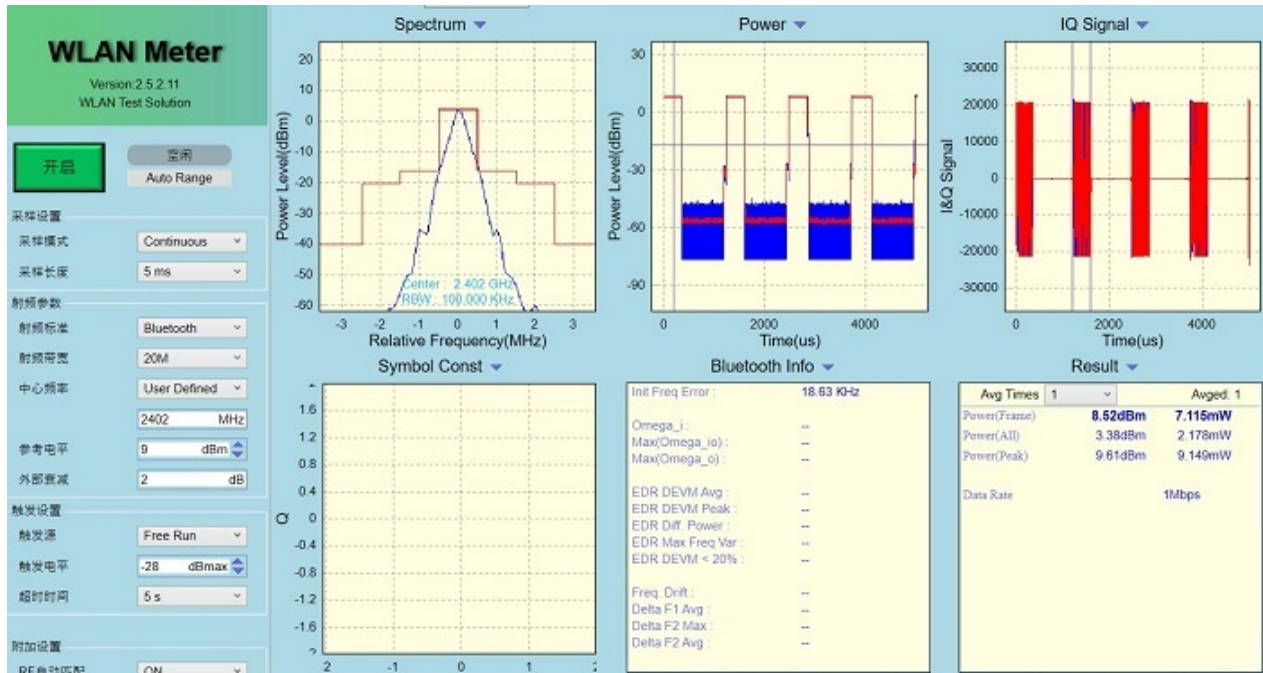

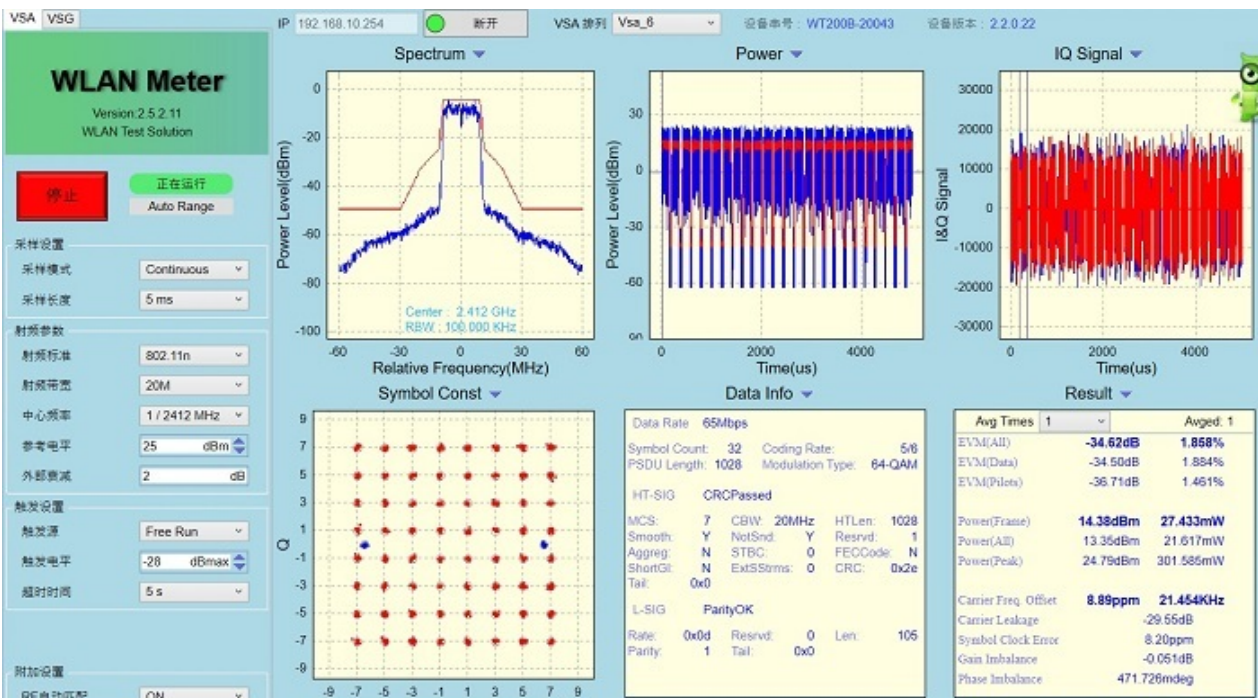
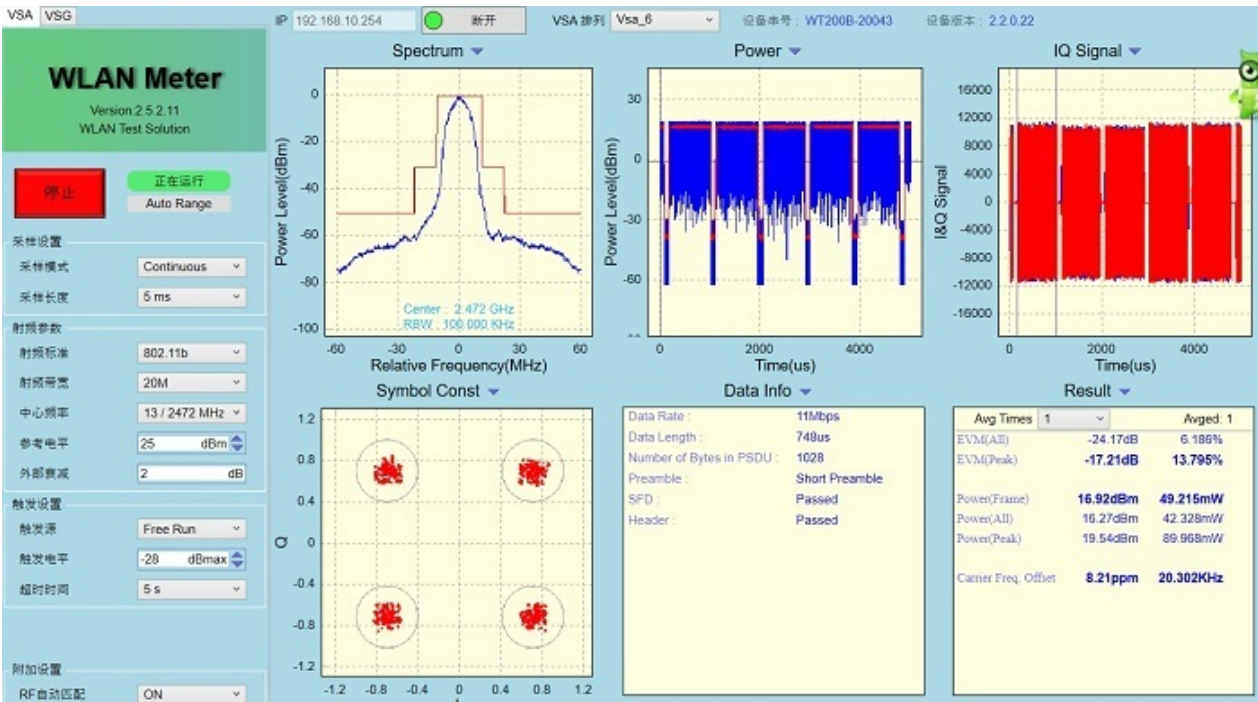

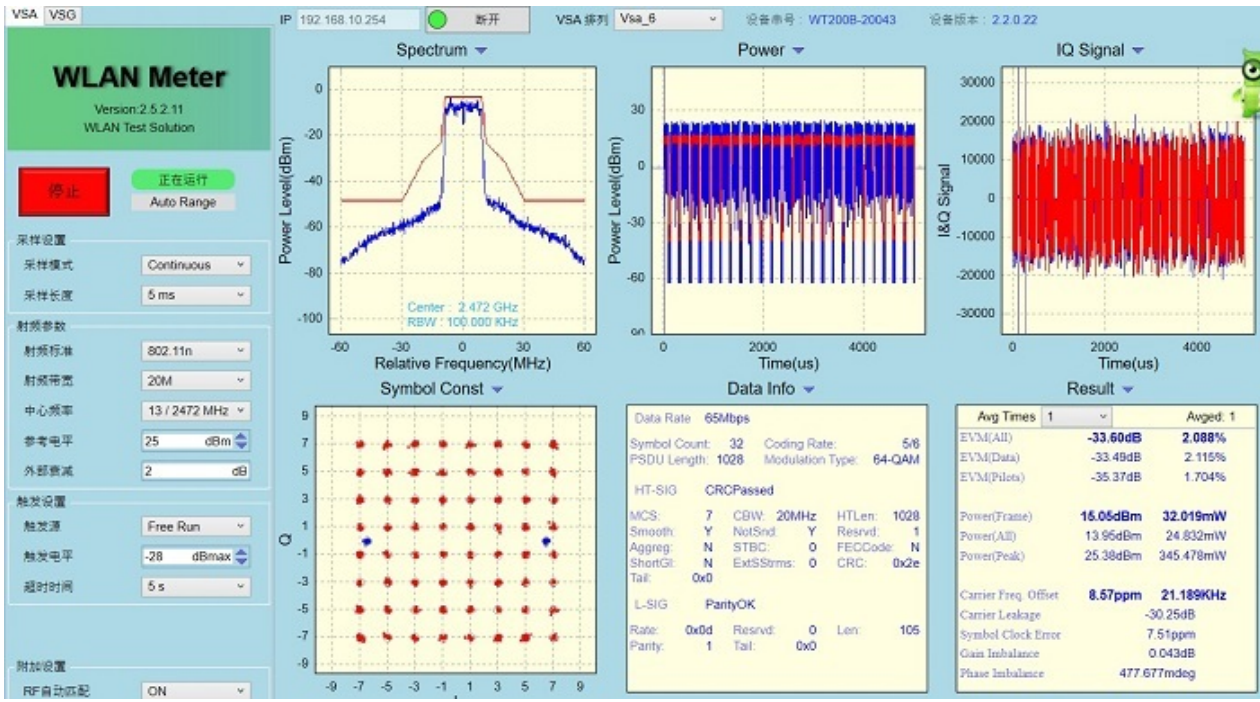

BPI-M2 Ultra validation test report

Banana Pi BPI-M2 Ultra have finished all validation test, all test pass, test report please download from below link:

Test Duration	2016/10/31 -- 2016/10/31	Project	Banana Pi
Model	M2 Ultra	REV.	V1.0
Product P/N	N/A	Product S/N	N/A
Equipment	Oscilloscope		
Sample photo			

BPI-M2_Ultra__DVT-DDR3(SKhynix)-SI_TR_Ver.A_20161031 validation test

<https://drive.google.com/file/d/0B4PAo2nW2KfnLUVWUnYzOGFyRkk/view?usp=sharing>

BPI-M2_Ultra_DVT-USB2.0-SI_TR_Ver.A_20161025 validation test

<https://drive.google.com/file/d/0B4PAo2nW2Kfnb2pfQmxCRUNUUm8/view?usp=sharing>

BPI-M2-Ultra_TR_20161031 validation test

<https://drive.google.com/file/d/0B4PAo2nW2KfnNFBBd0E5dmJsX28/view?usp=sharing>

DVT_Connectivity test RD-161024001-RF01_record validation test

<https://drive.google.com/file/d/0B4PAo2nW2KfnY2FycFBVvzRCb2c/view?usp=sharing>

M2-Ultra_EVT-HDMI(720p)_SI_TR_20161021 validation test

<https://drive.google.com/file/d/0B4PAo2nW2KfnNC1oWUx2Q3B0aGc/view?usp=sharing>

M2-Ultra_EVT-HDMI(1080p)_SI_TR_20161021 validation test

<https://drive.google.com/file/d/0B4PAo2nW2KfnY2VacjZpeUpRajA/view?usp=sharing>

all test report download link on google driver:

<https://drive.google.com/drive/folders/0B4PAo2nW2KfnbGtMUnA2RUw1RE0?usp=sharing>

BPI-M2 Ultra CE,FCC RoHS Certification

BPI-M2 Ultra CE Certification



EC Declaration of Conformity

Based on the voluntary assessment of the product sample and technical file, we confirm that the above-mentioned product meets the requirements of the EC directive.

The following products have been tested by us with listed standards and found in compliance with the council Directive 1999/5/EC.

Certificate No.: YRT201612264C
Applicant: GUANGDONG BIPAI KEJI.CPA.,LTD
Address: 7th floor, RongYi Building, Songshan Lake
 High-tech Industrial Development Zone, Dongguan
Manufacturer: SINOVOIP CO., LIMITED
Address: 7/F, ZTE Comprehensive Building of Zhongxing Industry City,
 Chuangye Road, Nanshan District, Shenzhen, Guangdong, China
Product: Banana PI BPI-M2 Ultra
Model: BPI-M2 Ultra
Brand Name: N/A

The submitted products have been tested by us with listed standards and found in compliance with the following European Directives:

The RTTE Directive 1999/5/EC

Applied Standards	Report No.
Article 3.2: Effective Use of The Radio Spectrum	YRT201612264E-2
EN 300 328 V1.8.1(2012-06)	YRT201612264E-4
Article 3.1b): Electromagnetic Compatibility	YRT201612264E-1
EN 301 489-1 V1.9.2: 2011-09	
EN 301 489-17 V2.2.1: 2012-09	
Article 3.1a): Health and Safety	
EN 62479:2010	YRT201612264E-3
EN 60950-1:2006+A11:2009+A1:2010+A12:2011+A2:2013	YRT201612264S



Approved by: _____

Department Manager
December 30, 2016

SHENZHEN YARUI TESTING CO., LTD.

Address: No. 620 HuaYuan Commercial Center, No. 347 XiXiang Road, XiXiang Town, Bao'An District, ShenZhen City

Tel.: +86-755-27912080 Fax.: +86-755-27916936 Website: www.yarui-lab.com

CERTIFICAT ♦ CERTIFICADO ♦ YARUITESTING ♦ ZERTIFIKAT ♦ CERTIFICATE



Certificate of Conformity

Certificate No.: YRT201612266C
Applicant: GUANGDONG BIPAI KEJI.CPA.,LTD
Address: 7th floor, RongYi Building, Songshan Lake
 High-tech Industrial Development Zone, Dongguan
Manufacturer: SINOVOIP CO., LIMITED
Address: 7/F, ZTE Comprehensive Building of Zhongxing Industry City,
 Chuangye Road, Nanshan District, Shenzhen, Guangdong, China
Product: Banana PI BPI-M2 Ultra
Model: BPI-M2 Ultra
Brand Name: N/A
Report No.: YRT201612266-1F, YRT201612266-2F

The submitted products have been tested by us with listed standards and found in compliance with the following FCC Rules and Regulations:

The FCC Standard:
FCC CFR 47 PART 15 C(15.247): 2014

The test were performed in normal operation mode. The test results apply only to the particular sample tested and to the specific tests carried out. This certificate applies specifically to the sample investigated in our test reference number only.

The FCC marking as shown below can be affixed on the product after preparation of necessary technical documentation.

Other relevant Directives have to be observed.



Approved by: 
Department Manager
December 30, 2016

SHENZHEN YARUI TESTING CO., LTD.

Address: No. 620 HuaYuan Commercial Center, No. 347 XiXiang Road, XiXiang Town, Bao'An District, ShenZhen City
Tel.: +86-755-27912080 Fax.: +86-755-27916936 Website: www.yarui-lab.com

Certificate of Conformity



Certificate No.: YRT201612265C
Applicant: GUANGDONG BIPAI KEJI.CPA.,LTD
Address: 7th floor,RongYi Building, Songshan Lake
 High-tech Industrial Development Zone, Dongguan
Manufacturer: SINOVOIP CO., LIMITED
Address: 7/F, ZTE Comprehensive Building of Zhongxing Industry City,
 Chuangye Road, Nanshan District, Shenzhen, Guangdong, China
Product: Banana PI BPI-M2 Ultra
Model: BPI-M2 Ultra
Brand Name: N/A

The submitted products have been tested by us with listed standards and found in compliance with the following European Directives:

The RoHS Directive 2011/65/EU:

IEC62321-4: 2013;
IEC62321-5: 2013;
IEC62321:2008;
EN 14372:2004;
EPA 3540C:1996

The test were performed in normal operation mode. The test results apply only to the particular sample tested and to the specific tests carried out. This certificate applies specifically to the sample investigated in our test reference number only.

The RoHS marking as shown below can be affixed on the product after preparation of necessary technical documentation.

Other relevant Directives have to be observed.

RoHS

Approved by: _____



Department Manager
December 30, 2016

SHENZHEN YARUI TESTING CO., LTD.

Address: No. 620 HuaYuan Commercial Center, No. 347 XiXiang Road, XiXiang Town, Bao'An District, ShenZhen City
 Tel.: +86-755-27912080 Fax.: +86-755-27916936 Website: www.yarui-lab.com

BPI-M2 Berry CE Certification

CERTIFICAT ♦ CERTIFICADO ♦ YARUITESTING ♦ ZERTIFIKAT ♦ CERTIFICATE



EC Declaration of Conformity

Based on the voluntary assessment of the product sample and technical file, we confirm that the above-mentioned product meets the requirements of the EC directive.
The following products have been tested by us with listed standards and found in compliance with the council Directive 2014/53/EU.

Certificate No.:	YRT201707249C
Applicant:	GUANGDONG BIPAI KEJI.CPA.,LTD
Address:	7th floor, RongYi Building, Songshan Lake High-tech Industrial Development Zone, Dongguan
Manufacturer:	SINOVOIP CO., LIMITED
Address:	7/F, ZTE Comprehensive Building of Zhongxing Industry City, Chuangye Road, Nanshan District, Shenzhen, Guangdong, China
Product:	Banana PI BPI-M2 Berry
Model:	BPI-M2 Berry
Brand Name:	N/A

The submitted products have been tested by us with listed standards and found in compliance with the following European Directives:

The Radio Equipment Directive(RED) 2014/53/EU

Applied Standards	Report No.
Article 3.2: Effective Use of The Radio Spectrum	YRT201707249E-2
ETSI EN 300 328 V2.1.1(2016-11)	YRT201707249E-4
Article 3.1b): Electromagnetic Compatibility	YRT201707249E-1
ETSI EN 301 489-1 V2.1.1(2017-02)	
ETSI EN 301 489-17 V3.1.1(2017-02)	
Article 3.1a): Health and Safety	
EN 62479:2010	YRT201707249E-3
EN 60950-1:2006+A11:2009+A1:2010+A12:2011+A2:2013	YRT201707249S

CE



Approved by: _____
Department Manager
August 01, 2017

SHENZHEN YARUI TESTING CO., LTD.
Address: No. 620 HuaYuan Commercial Center, No. 347 XiXiang Road,XiXiang Town, Bao'An District, ShenZhen City
Tel.: +86-755-27912080 Fax.: +86-755-27916936 Website: www.yarui-lab.com

BPI-M2 Berry FCC Certification

CERTIFICAT ♦ CERTIFICADO ♦ YARUITESTING ♦ ZERTIFIKAT ♦ CERTIFICATE



Certificate of Conformity

Certificate No.: YRT201707250C
Applicant: GUANGDONG BIPAI KEJI.CPA.,LTD
Address: 7th floor, RongYi Building, Songshan Lake
 High-tech Industrial Development Zone, Dongguan
Manufacturer: SINOVOIP CO., LIMITED
Address: 7/F, ZTE Comprehensive Building of Zhongxing Industry City,
 Chuangye Road, Nanshan District, Shenzhen, Guangdong, China
Product: Banana PI BPI-M2 Berry
Model: BPI-M2 Berry
Brand Name: N/A
Report No.: YRT201707250-1F, YRT201707250-2F

The submitted products have been tested by us with listed standards and found in compliance with the following FCC Rules and Regulations:

The FCC Standard:
FCC CFR 47 PART 15 C(15.247): 2014

The test were performed in normal operation mode. The test results apply only to the particular sample tested and to the specific tests carried out. This certificate applies specifically to the sample investigated in our test reference number only.

The FCC marking as shown below can be affixed on the product after preparation of necessary technical documentation.

Other relevant Directives have to be observed.



Approved by: *[Signature]*
Department Manager
August 01, 2017

SHENZHEN YARUI TESTING CO., LTD.

Address: No. 620 HuaYuan Commercial Center, No. 347 XiXiang Road, XiXiang Town, Bao'An District, ShenZhen City
Tel.: +86-755-27912080 Fax.: +86-755-27916936 Website: www.yarui-lab.com

CERTIFICAT ♦ CERTIFICADO ♦ YARUITESTING ♦ ZERTIFIKAT ♦ CERTIFICATE



Certificate of Conformity

Certificate No.: YRT201707251C
Applicant: GUANGDONG BIPAI KEJI.CPA.,LTD
 7th floor,RongYi Building, Songshan Lake
Address: High-tech Industrial Development Zone, Dongguan
Manufacturer: SINOVOIP CO., LIMITED
Address: 7/F, ZTE Comprehensive Building of Zhongxing Industry City,
 Chuangye Road, Nanshan District, Shenzhen, Guangdong, China
Product: Banana PI BPI-M2 Berry
Model: BPI-M2 Berry
Brand Name: N/A
Report No.: YRT201707251R

The submitted products have been tested by us with listed standards and found in compliance with the following European Directives:

The RoHS Directive 2011/65/EU:
IEC62321-3-1: 2013 IEC62321-4: 2013 IEC62321-5: 2013 IEC62321-6: 2015 IEC62321-7-1: 2013 IEC62321:2008 ANNEX C

The test were performed in normal operation mode. The test results apply only to the particular sample tested and to the specific tests carried out. This certificate applies specifically to the sample investigated in our test reference number only.

The RoHS marking as shown below can be affixed on the product after preparation of necessary technical documentation.

Other relevant Directives have to be observed.

RoHS

Approved by: _____



Department Manager
August 01, 2017

SHENZHEN YARUI TESTING CO., LTD.

Address: No. 620 HuaYuan Commercial Center, No. 347 XiXiang Road, XiXiang Town, Bao'An District, ShenZhen City
 Tel.: +86-755-27912080 Fax.: +86-755-27916936 Website: www.yarui-lab.com

All Banana Pi SBC Comparison

Banana Pi series comparison_20170612

Banana Pi (BPI) Series Comparison

Model	Banana Pi BPI-M1	Banana Pi BPI-M1+	Banana Pi BPI-M2M	Banana Pi BPI-M2+	Banana Pi M2 Berry	Banana Pi BPI-M2 Ultra	Banana Pi BPI-M3	Banana Pi BPI-M64	
Photo									
CPU	A20 32 Bit Cortex™-A7 Quad-Core		A83/R16 32 Bit Cortex™-A7 Quad-Core		R40 32 Bit Cortex™-A7 Quad-Core		A83T 32 Bit Cortex™-A7 Quad-Core		
GPU	ARM® Mali400MP2		ARM® Mali400MP2		ARM® Mali400MP2		PowerVR SGX544MP2 GPU		
SDRAM	1GB DDR3 (shared with GPU)		512MB DDR3		1GB DDR3 (shared with GPU)		2GB LPDDR3 (shared with GPU)		
Storage	SD (Max. 32GB)/MMC card slot SATA 2.0 port via SOC	MicroSD (TF) card / MMC card slot SATA 2.0 port via SOC	MicroSD (TF) card / MMC card slot eMMC R08 (option)	MicroSD (TF) card / MMC card slot eMMC R08	MicroSD (TF) card / MMC card slot SATA 2.0 port via SOC	MicroSD (TF) card / MMC card slot eMMC R08 SATA 2.0 port via SOC	MicroSD (TF) card / MMC card slot eMMC R08	MicroSD (TF) card / MMC card slot eMMC R08	
Network	10/100/1000 Ethernet		N/A		10/100/1000 Ethernet		10/100/1000 Ethernet		
RF	N/A		802.11b/g/n & BT4.0		802.11b/g/n & BT4.0		802.11b/g/n & BT4.0		
Display	HDMI, CVBS, LVDS/RGB		MIPI/LVDS		HDMI		HDMI, MIPI		
Camera	Parallel 8-bit camera interface		Parallel 8-bit camera interface		Parallel 8-bit camera interface		Parallel 8-bit camera interface		
Video Outputs	HDMI 1.4@1920*1080P LVDS/Sync/RGB/CPUI LCD interface up to 1920x1200 Video decoding speed up to 1080p@60fps Video encoding H.264 HP up to 1080p@30fps	HDMI 1.4@1920*1080P H.264 HP video encoding up to 1920x1080@60fps	Decoding up to 1920x1080@60fps Support H.264 video encoding up to 1080p@30fps	Support H.265 decode by 4K@30fps HDMI 1.4 1080p@60fps Support H.264 video encoding up to 1080p@30fps	HDMI 1.4 1080p@60fps MIPI LCD interface up to 1920x1080 Decoding up to 1920x1080@60fps Video encoding H.264 HP speed up to 1080p@30fps	HDMI 1.4 1080p@60fps MIPI LCD interface up to 1920x1080 Decoding up to 1920x1080@60fps Video encoding H.264 HP speed up to 1080p@30fps	HEVC/H.265 decoder(S/W), Main profile, 1080p@60fps H.264 video encoding up to 1080p@60fps, 720p@120fps	Multi-format H265 video decoding, including MPEG4, H.264, H.265, etc H.264 video encoding up to 1080p@60fps, 720p@120fps	Multi-format H265 video decoding, including MPEG4, H.264, H.265, etc H.264 video encoding up to 1080p@60fps, 720p@120fps
Audio Output	3.5 mm Jack and HDMI		4ohm(2.5W) Speaker (2 Pin Hole)		HDMI		3.5 mm Jack and HDMI		
Audio In	Microphone		Microphone		Microphone		Microphone		
GPIO	26 PIN: GPO, UART, I2C bus, SPI bus with two chip selects, CAN bus, PWM, +3.3V, +5V, ground		40 PIN: PWM, GPIO, UART, I2C bus, I2S bus, SPI bus, +3.3V, +5V, ground		40 PIN: PWM, GPIO, UART, I2C bus, I2S bus, SPI bus, +3.3V, +5V, ground		40 PIN: PWM, GPIO, UART, I2C bus, I2S bus, SPI bus, +3.3V, +5V, ground		
Power Source	5 volt via MicroUSB and/or MicroUSB (OTG)		5 volt via DC In and/or MicroUSB (OTG)		5 volt via DC In and/or MicroUSB (OTG)		5 volt via DC In and/or MicroUSB (OTG)		
USB 2.0 Ports	2 USB ports, 1 OTG microUSB port		1 USB 2.0 ports, 1 OTG microUSB port		4 USB ports, 1 OTG microUSB port		2 USB ports, 1 OTG microUSB port		
Buttons	Reset button, Power button, Usbport button		Power button, Usbport button		Reset button, Power button, Usbport button		Reset button, Power button, Usbport button		
LED	Power LED (red), IRAS LED (blue), user define LED (green)		User define LED (red/power, blue, green)		Power LED (red, Can be defined by user)		User define LED (red/power, blue, green)		
Remote	IR receiver		N/A		IR receiver		IR receiver		
Board Size	92 mm × 60mm		51 mm × 51mm		85mm × 55mm		92 mm × 60mm		
Box Size	92 mm × 60mm		51 mm × 51mm		85mm × 55mm		92 mm × 60mm		
Weight	60g		40g		40g		60g		
OS	Android and Linux etc. OS								





Banana Pi series comparison_20170612 excel file download:

<https://drive.google.com/file/d/0B4PAo2nW2KfnUIVfQ2NQRTF2b2M/view?usp=sharing>

Banana Pi series comparison_20170612 pdf file download:







<https://drive.google.com/file/d/0B4PAo2nW2KfnaG8zdXBhUThUYXc/view?usp=sharing>

Banana Pi (BPI) Series Comparison

Model	Banana Pi BPI-M1	Banana Pi BPI-M1+	Banana Pi BPI-M2+	Banana Pi BPI-M2	Banana Pi BPI-M3
Photo					
CPU	A20 Cortex™-A7 Dual-Core		H3 Cortex™-A7 Quad-Core	A31S Cortex™-A7 Quad-Core	A83T Cortex™-A7 Octa-Core
GPU	ARM® Mali400MP2 Complies with OpenGL ES 2.0/1.1			PowerVR SGX544MP2 GPU Support OpenGL ES 2.0, OpenVG 1.1, and DX 9.3 standards	PowerVR SGX544 GPU 2GB LPDDR3 (shared with GPU)
SDRAM	1GB DDR3 (shared with GPU)				
Storage	SD (Max. 32GB)/MMC card slot, SATA 2.0 port via CPU	MicroSD (TF) card / MMC card slot, SATA 2.0 port via CPU	MicroSD (TF) card, eMMC 8GB	MicroSD (TF) card / MMC card slot	MicroSD (TF) card, eMMC 8GB SATA 2.0 port via USB
Network	N/A		10/100/1000 Ethernet	802.11b/g/n & BT4.0	
RF	802.11b/g/n				
Display	HDMI, CVBS, LVDS/RGB		HDMI	HDMI, LVDS/RGB	
Camera	Parallel 8-bit camera interface				HDMI, MIPI Display Serial Interface (DSI) MIPI Camera serial interface (CSI)
Video Outputs	HDMI 1.4 transmitter with HDCP LVDS/Sync RGB/CPU LCD interface up to 1920x1200 Video decoding speed up to 1080p@60fps Video encoding H.264 HP up to 1080p@30fps		Support H.265 decode by 4K@30fps, HDMI 1.4 1080p@60fps Support H.264 video encoding up to 1080p@30fps	HDMI 1.4 1080p@60fps LVDS/RGB/CPU LCD interface 1280x800 Decoding up to 1920x1080@60fps Video encoding H.264 HP: speed up 1920x1080@30fps	Support 4-lane MIPI DSI up to 1920x1200@60Hz HDMI 1.4 output with HDCP 1.2 Support LVDS up to 1366x768@60Hz HEVC/H.265 decoder(SW), Main profile, 1080p@30fps H.264 video encoding up to 1080p@60fps, 720p@120fps
Audio Output	3.5 mm Jack and HDMI		HDMI	3.5 mm Jack and HDMI	
GPIO	26-PIN: GPIO, UART, I²C bus, SPI bus with two chip selects, CAN bus, PWM, +3.3 V, +5 V, ground	40-PIN: GPIO, UART, I²C bus, I²S bus, SPI bus with two chip selects, CAN bus, PWM, +3.3 V, +5 V, ground	40-PIN: PWM, GPIO, UART, I²C bus, I²S bus, SPI bus, +3.3v, +5v, ground.		
Power Source	5 volt via MicroUSB and/or MicroUSB (OTG)			5 volt via DC In and/or MicroUSB (OTG)	
USB 2.0 Ports	2 USB ports, 1 OTG microUSB port			4 USB 2.0 ports, 1 OTG microUSB port	
Buttons	Reset button, Power button, Uboot button			Power button, Uboot button Reset button, Power button, Uboot button	
LED	Power LED (red), RJ45 LED (blue), user define LED (green)		IR receiver	User define LED (red/power, blue, green)	
Remote	IR receiver				
Board Size	92 mm × 60mm		65 × 65mm	92 mm × 60mm	
Box Size	20 mm × 80mm × 105mm				
Weight	60g		48g	60g	
OS	Android 4.4 and Linux etc. OS				

add BPI-M2 Ultra and BPI-M64



Banana Pi (BPI) Series Comparison

Model	Banana Pi BPI-M1	Banana Pi BPI-M1+	Banana Pi BPI-M2	Banana Pi BPI-M2+	Banana Pi BPI-M2 Ultra	Banana Pi BPI-M3	Banana Pi BPI-M64
Photo							
CPU	A20 32 Bit Cortex™-A7 Dual-Core		A31S 32 Bit Cortex™-A7 Quad-Core	H3 32 Bit Cortex™-A7 Quad-Core	R40 32 Bit Cortex™-A7 Quad-Core	A83T 32 Bit Cortex™-A7 Octa-Core	A64 64 Bit Cortex-A53 Quad Core
GPU	ARM® Mali400MP2			ARM® Mali400MP2	ARM® Mali400MP2	PowerVR SGX544MP2 GPU	ARM® Mali400MP2
SDRAM	1GB DDR3 (shared with GPU)					2GB DDR3 (shared with GPU)	3GB LPDDR3 (shared with GPU)
Storage	SD (Max. 32GB)/MMC card slot SATA 2.0 port via SOC	MicroSD (TF) card / MMC card slot SATA 2.0 port via SOC	MicroSD (TF) card / MMC card slot	MicroSD (TF) card, eMMC 8GB	MicroSD (TF) card, eMMC 8GB SATA 2.0 port via SOC, SATA ports	MicroSD (TF) card, eMMC 8GB SATA 2.0 port via USB	MicroSD (TF) card, eMMC 8GB
Network	N/A		10/100/1000 Ethernet		802.11b/g/n & BT4.0		
RF	802.11b/g/n						
Display	HDMI, CVBS, LVDS/RGB		HDMI, LVDS/RGB		HDMI		
Camera	Parallel 8-bit camera interface				HDMI, MIPI Display Serial Interface (DSI) MIPI Camera serial interface (CSI)		Parallel 8-bit camera interface
Video Outputs	HDMI 1.4 transmitter with HDCP LVDS/Sync RGB/CPU LCD interface up to 1920x1200 Video decoding speed up to 1080p@60fps Video encoding H.264 HP up to 1080p@30fps		HDMI 1.4 1080p@60fps LVDS/RGB/CPU LCD interface 1280x800 Decoding up to 1920x1080@60fps Video encoding H.264 HP: speed up 1920x1080@30fps	Support H.265 decode by 4K@30fps, HDMI 1.4 1080p@60fps Support H.264 video encoding up to 1080p@30fps	HDMI 1.4 1080p@60fps MIPI LCD interface up to 1920x1080 Decoding up to 1920x1080@60fps Video encoding H.264 HP: speed up 1920x1080@30fps	Support 4-lane MIPI DSI up to 1920x1200@60Hz HDMI 1.4 output with HDCP 1.2 HEVC/H.265 decoder(SW), Main profile, 1080p@30fps H.264 video encoding up to 1080p@60fps, 720p@120fps	Multi-format FHD video decoding including MPEG-2, MPEG-4, H.264, etc. H.264 decode up to 1080p@60, H.265 decode up to 4K@30
Audio Output	3.5 mm Jack and HDMI		HDMI		3.5 mm Jack and HDMI		
GPIO	26-PIN: GPIO, UART, I²C bus, SPI bus with two chip selects, CAN bus, PWM, +3.3 V, +5 V, ground	40-PIN: GPIO, UART, I²C bus, I²S bus, SPI bus with two chip selects, CAN bus, PWM, +3.3 V, +5 V, ground	40-PIN: PWM, GPIO, UART, I²C bus, I²S bus, SPI bus, +3.3v, +5v, ground.	40-PIN: PWM, GPIO, UART, I²C bus, I²S bus, SPI bus, +3.3v, +5v, ground.			
Power Source	5 volt via MicroUSB and/or MicroUSB (OTG)			5 volt via DC In and/or MicroUSB (OTG)			
USB 2.0 Ports	2 USB ports, 1 OTG microUSB port			4 USB 2.0 ports, 1 OTG microUSB port			
Buttons	Reset button, Power button, Uboot button			Reset button, Power button, Uboot button			
LED	Power LED (red), RJ45 LED (blue)		User define LED (red/power, blue, green)	Power LED (red, can be defined by user)	Reset button, Power button, Uboot button User define LED (red/power, blue, green)		
Remote	IR receiver						
Board Size	92 mm × 60mm		92 mm × 60mm		65 × 65mm		
Box Size	20 mm × 80mm × 105mm						
Weight	60g		60g		48g		

Excel file download, you can help us to edit it:

<https://drive.google.com/file/d/0B4PAo2nW2KfnQzZSSS15UWJTa2c/view?usp=sharing>

BPI-M3 Vs Odroid-XU4

Model	BPI M3	ODROID-XU4
Price	\$74	\$74
Pic		
Processor	A83T ARM Cortex-A7 octa-core 1.8GHz,512 KB L1 cache 1 MB L2 cache	Samsung Exynos5422 Cortex™-A15 2Ghz and Cortex™-A7 Octa core CPUs
GPU	PowerVR SGX544MP1· Comply with OpenGL ES 2.0, OpenCL 1.x, DX 9_3 OpenGL ES 3.0/2.0, OpenCL 1.x, DX9_3	Mali-T628 MP6(OpenGL ES 3.0/2.0/1.1 and OpenCL 1.1 Full profile)
RAM	2GB LPDDR3 (shared with GPU)	2Gbyte LPDDR3 RAM PoP stacked
Storage	MicroSD (TF) card, eMMC 8GB, SATA 2.0 port via USB	MicroSD (TF) card, Non EMMC 8GB, Non SATA port
Display	HDMI, MIPI Display Serial Interface (DSI)	Non MIPI DSI
Video In	Parallel 8-bit camera interface, MIPI Camera serial Interface(CSI)	Non MIPI Camera
Video Out	HDMI 1.4 DHCP 1.2 with resolutions from(640x640 to 1920x1080) MIPI DSI for RAW LCD panels	Standard Type-A HDMI, supports up to 1920 x 1080 resolution
Ethernet	10/100/1000Mbps ethernet (Realtek RTL8211E/D)	The Realtek RTL8153-CG 10/100/1000M Ethernet
WIFI	802.11 b/g/n (AP6212)	Non WIFI
BT	BT4.0 (AP6212)	Non BT
Audio In	On board microphone	Non Microphone
Audio Out	HDMI & 3.5 mm audio Jack	HDMI, Non 3.5 mm audio jack
USB	2x USB 2.0 & MicroUSB OTG	2 x USB 3.0 Host, 1 x USB 2.0 Host, Non MicroUSB OTG
GPIO	40 Pins: GPIO, UART, I2C bus, I2S bus, SPI bus, PWN, +3.3v, +5v, ground	30Pin : GPIO/IRQ/SPI/ADC, 12Pin : GPIO/I2S/I2C
Power	DC-IN 5V DC port	5V4A PSU (5.5mm barrel connector)
PCB Size	90 x 60mm	82 x 58 mm
OS	Android 5.x and Linux OS	Android 5.x and Linux OS

All banana pi product

- **banana pi BPI-M1 allwinner A20 dual core single board computer**
gitbook online datasheet:<https://bananapi.gitbooks.io/bpi-m1/content/en/>
- **banana pi BPI-M1+(BPI-M1+ plus) allwinner A20 dual core single board computer**
gitbook online datasheet:<https://bananapi.gitbooks.io/bpi-m1-bpi-m1-plus-/content/en/>
- **banana pi BPI-M2+ (BPI-M2 Plus,BPI-M2+ edu) allwinner H3/H2+/H5 quad core single board computer**
gitbook online datasheet:<https://bananapi.gitbooks.io/bpi-m2-/content/en/>
- **banana pi BPI-M2 Ultra allwinner R40/V40 quad core single board computer**
gitbook online datasheet:<https://bananapi.gitbooks.io/bpi-m2-ultra/content/>
- **banana pi BPI-M2 Berry allwinner R40/V40 quad core single board computer**
gitbook online datasheet:<https://bananapi.gitbooks.io/bpi-m2-ultra/content/>
- **banana pi BPI-M2 Magic allwinner R16/A33 quad core single board computer**
gitbook online datasheet: <https://bananapi.gitbooks.io/banana-pi-bpi-m2-magic-iot-development-board/content/>
- **Banana pi BPI-M3 allwinner A83T (R58 H8) octa-core single board computer**
gitbook online datasheet:<https://bananapi.gitbooks.io/bpi-m3/content/en/>
- **banana pi BPI-M64 allwinner A64/R18 64 bit single board computer**
gitbook online datasheet:<https://bananapi.gitbooks.io/bpi-m64/content/en/>
- **banana pi BPI-R1 allwinner A20 dual core smart router board**
gitbook online datasheet:<https://bananapi.gitbooks.io/bpi-r1/content/en/>
- **banana pi BPI-R2 MTK 7623N smart router board**
gitbook online datasheet:<https://bananapi.gitbooks.io/banana-pi-bpi-r2-open-source-smart-router/content/>
- **banana pi BPI-D1 open source IP camera board**
gitbook online datasheet:<https://bananapi.gitbooks.io/bpi-d1/content/en/>

- **banana pi BPI-G1 open source IoT development board**

gitbook online datasheet:<https://bananapi.gitbooks.io/bpi-g1/content/en/>

- **banana pi BPI Accessories**

gitbook online datasheet:<https://bananapi.gitbooks.io/bpi-accessories/content/en/>

- **BPI Open debugger burn development tool board**

gitbook online datasheet:<https://bananapi.gitbooks.io/bpi-open-debugger-burn-board/content/en/>

Stop production

- **banana pi BPI-M2 allwinner A31s quad core single board computer**

- gitbook online datasheet:datasheet: <https://bananapi.gitbooks.io/bpi-m2/content/en/>