Table of Contents

About BPI-M2+/M2 Zero	1.1
BPI-M2 Zero hardware	1.2
BPI-M2 Zero hardware interface	1.2.1
BPI-M2 Zero hardware spec	1.2.2
BPI-M2 Zero Pin define	1.2.3
BPI-M2 Zero micro SD card slot	1.2.4
BPI-M2 Zero WIFI interface	1.2.5
BPI-M2 Zero bluetooth interface	1.2.6
BPI-M2 Zero wifi antenna slot	1.2.7
BPI-M2 Zero RJ45 PIN	1.2.8
BPI-M2 Zero Mini HDMI interfact	1.2.9
BPI-M2 Zero OTG interface	1.2.10
BPI-M2 Zero UART port	1.2.11
BPI-M2 Zero CSI camera interface	1.2.12
BPI-M2 Zero schematic	1.2.13
BPI-M2 Zero RJ45 PIN	1.2.14
BPI-M2+ hardware	1.3
BPI-M2+ hardware interface	1.3.1
BPI-M2+ hardware spec	1.3.2
BPI-M2+ Pin define	1.3.3
BPI-M2+ micro SD card slot	1.3.4
BPI-M2+ GigE LAN	1.3.5
BPI-M2+ eMMC flash	1.3.6
BPI-M2+ WIFI interface	1.3.7
BPI-M2+ wifi antenna slot	1.3.8
BPI-M2+ bluetooth interface	1.3.9
BPI-M2+ IR interface	1.3.10
BPI-M2+ HDMI interfact	1.3.11
BPI-M2+ USB interface	1.3.12
BPI-M2+ OTG interface	1.3.13
BPI-M2+ CSI camera interface	1.3.14
BPI-M2+ UART port	1.3.15
BPI-M2+ Power interface	1.3.16
BPI-M2+ schematic diagram	1.3.17
BPI-M2+ DXF and 3D design	1.3.18
BPI-M2+/BPI-M2 Zero software	1.4
BPI-M2+ Quick Start	1.4.1
Android software	1.4.2
Android 4.4 source code	1.4.2.1

How to burn android image to eMMC	1.4.2.2
Linux software	1.4.3
How to burn Linux image to eMMC	1.4.3.1
Linux for Kernel 3.4 image	1.4.3.2
how to use BPI-M3 image on BPI-M2+ , use bpi-bootsetl	1.4.3.2.1
mainline Linux image	1.4.3.3
uboot	1.4.3.3.1
mainline kernel	1.4.3.3.2
BPI-M2+ WiringPi	1.4.4
OpenWRT	1.4.5
BPI-tools	1.4.6
bpi-bootsetl command	1.4.6.1
bpi-get command	1.4.6.2
bpi-copy command	1.4.6.3
bpi-update	1.4.6.4
Openelec	1.4.7
Lakka TV	1.4.8
Dietpi	1.4.9
RetrOrangePi	1.4.10
FreeBSD/NetBSD	1.4.11
BPI-M2+/BPI-M2 Zero source code on github	1.5
BPI-M2+ fix rootmydevice issue for Security Alert	1.5.1
How to setup docker env. to build github source code	1.5.2
How to compile BPI-M2+ BSP and boot image	1.5.3
Reference documents	1.6
H3 Linux-sunxi wiki	1.6.1
H3 Manual build howto	1.6.2
BPI-M2+ linux-sunxi wiki	1.6.3
Banana pi wikipedia wiki	1.6.4
BPI-M2+ online video	1.6.5
Allwinner GPL_Violations	1.6.6
Linux mainlining effort	1.6.7
Allwinner chip documents	1.6.8
BPI-M2+ quality guarantee	1.7
BPI-M2+ BT4.0 Lab test	1.7.1
BPI-M2+ WIFI Lab test	1.7.2
BPI-M2+ validation test report	1.7.3
HDMI 720P validation report	1.7.3.1
HDMI 1080P validation report	1.7.3.2
WIFI&BT validation report	1.7.3.3
Samsung DDR validation report	1.7.3.4
USB validation report	1.7.3.5

Power validation report	1.7.3.6
BPI-M2+ CE,FCC RoHS Certification	1.7.4
All Banana Pi SBC Comparison	1.8
All banana pi product	1.9
BPI 4.0 customized Server	1.10

About banana pi BPI-M2+/BPI-M2 Zero/BPI-M2+ EDU/BPI-M2+ (H2)/BPI-M2+ (H5)

BPI-M2+ Version with Allwinner H3 chip design

Banana Pi M2+

Quad-core H3 SoC
1GB DDR3 8GB eMMC
WiFi & BT4.0 on board
Gigabit LAN



Banana Pi BPI-M2+ is the open source hardware platform, Banana Pi BPI-M2+ is a quad core version of Banana Pi, it supports WiFi on board. uses Allwinner H3 chip on board. and mini size only 65mm*65mm

Banana Pi BPI-M2+ series run Android, Debian Linux, Ubuntu Linux, Raspberry Pi image and others image.

Banana Pi BPI-M2 hardware: 1GHz ARM7 quad-core processor, 1GB DDR3 SDRAM, 8GB eMMC flash on board, and SDIO WiFi module on board.

Banana Pi BPI-M2+ with Gigabit Ethernet port, it can run with Android 4.4 smoothly. it can easily run with the game. it supports 1080P high definition video output and 4K support, the GPIO is compatible with Raspberry Pi B+ and can support Raspbian image download from our website

Note:

- Banana Pi BPI-M2+ does not support SATA port, so you need use USB for hardisk
- Banana pi BPI-M2+ does not support LCD interface ..

BPI-M2+ EDU Version with Allwinner H3 chip design

BPI-M2+ EDU is a cost-down version, we may remove 8GB eMMC and on-board WiFi module. so, everyone can free DIY on this board.



BPI-M2 Zero Version with Allwinner H2+ chip design

this board is same size as Raspberry pi Zero W. you can use Raspberry pi Zero W case on it.



BPI-M2+ (H2)/BPI-M2+ (H5) Version

allwinner H2+ chip H3 chip and H5 chip is PIN to PIN compatibility, so BPI-M2+ just replace H2+ ,H5 chip onboard, easy to DIY new product.just main chip is different, other spec is same as BPI-M2+ with allwinner H3 design

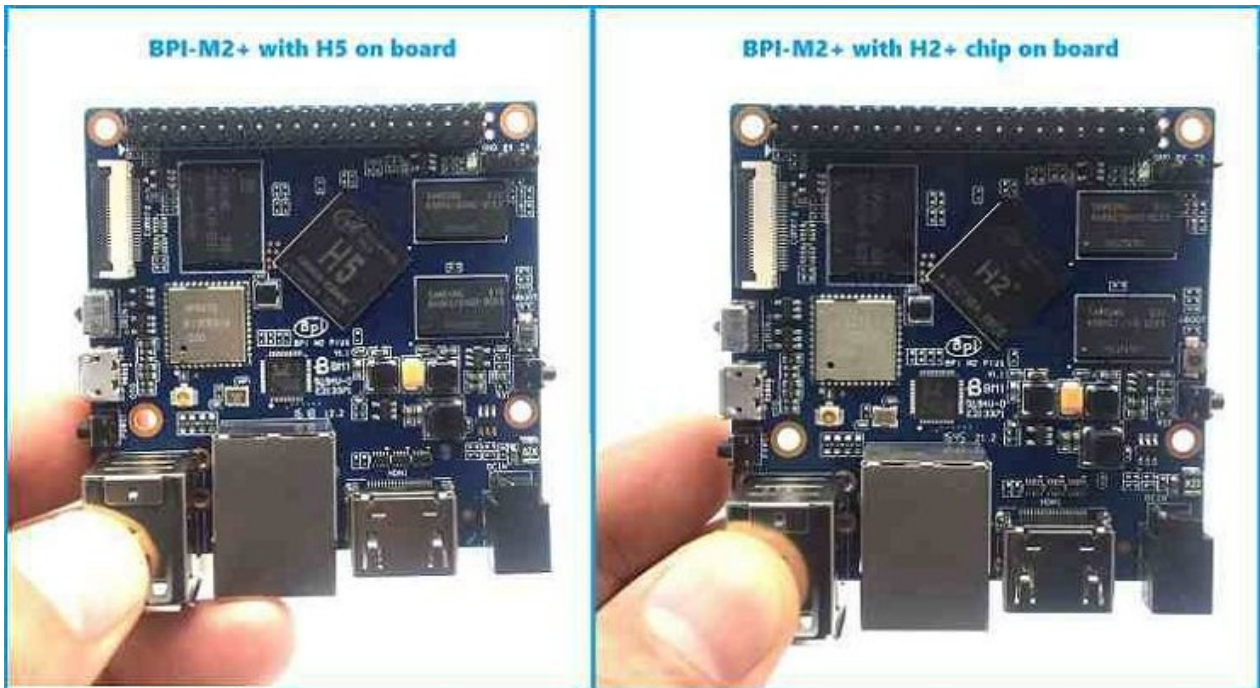

forum: <http://www.banana-pi.org>

forum: <http://www.bananapi.com>

product: <http://www.banana-pi.com>

easy to buy a sample :



Banana Pi BPI-M2 Zero is the open source hardware platform, Banana Pi BPI-M2 Zero is an quad core version of Banana Pi, it support WIFI on board. use Allwinner H2+ chip on board. and mini size only 60mm*30mm, all ineter face same as Raspberry pi Zero W.

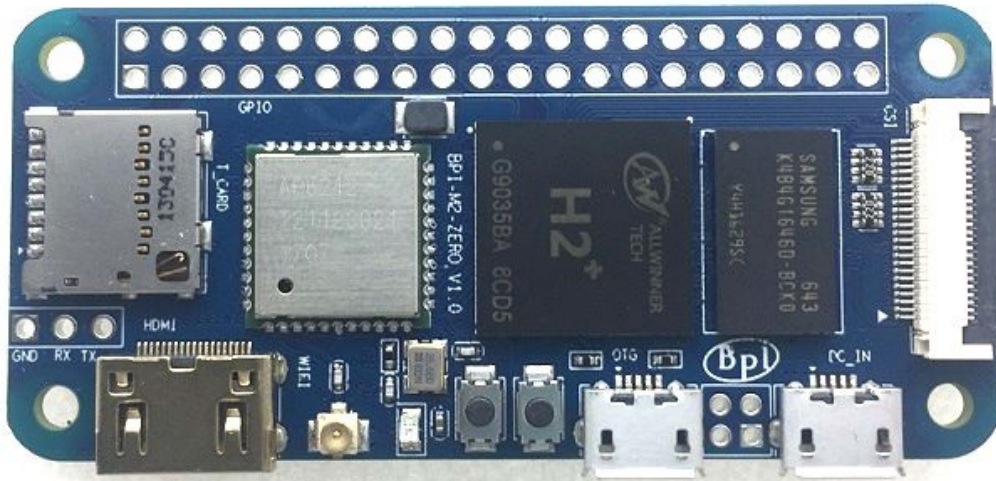

Banana Pi BPI-M2 Zero series run Android, Debian linux, Ubuntu linux, Raspberry Pi image and others image.

Banana Pi BPI-M2 Zero hardware: 1Ghz ARM7 quad-core processor, 512M DDR3 SDRAM, and SDIO wifi&BT module on board.

Banana pi BPI-M2 Zero all size is same as Raspberry pi Zero W.

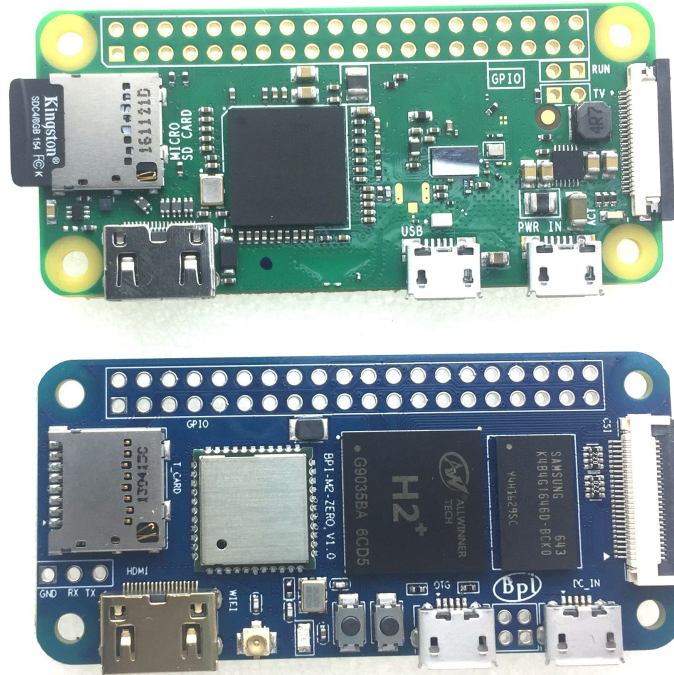

BPI-M2 Zero hardware interface

BPI-M2 Zero hardware spec

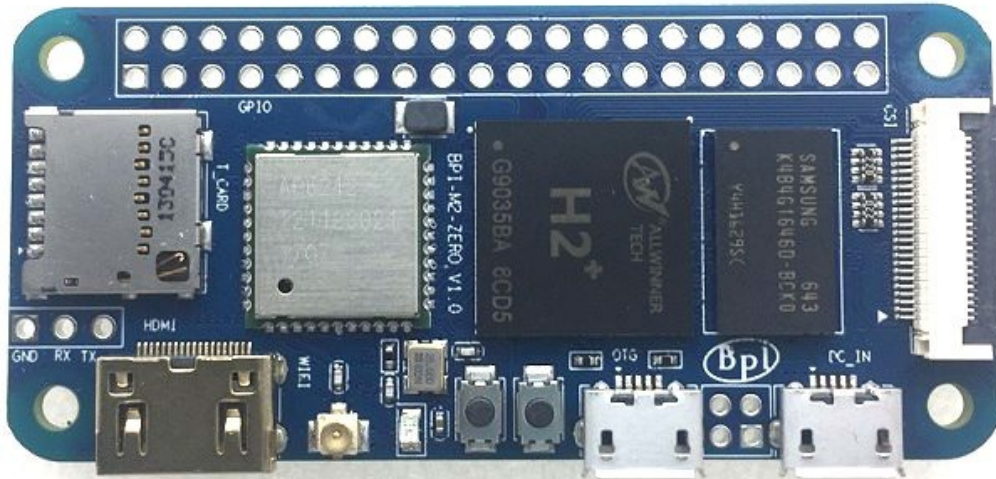

Hardware specification

CPU	H2+ Quad-core Cortex-A7 H265/HEVC 1080P
	Mali400MP2 GPU @600MHz, Supports OpenGL ES 2.0
Memory (SDRAM)	512M (shared with GPU)
Onboard Storage	TF card (Max. 64GB)
Onboard Network	NOPE
Onboard WIFI	SDIO AP6212 (option AP6181 、 AP6335)
Video Input	A CSI input connector Camera:1 Supports 8-bit YUV422 CMOS sensor interface,2 Supports CCIR656 protocol for NTSC and PAL,3 Supports SM pixel camera sensor ,4 Supports video capture solution up to 1080p@30fps
Video Outputs	Supports Mini HDMI Port
Audio Output	Mini HDMI
Power Source	Micro USB with 5V/2A
USB 2.0 Ports	one USB 2.0 OTG
Buttons	Power Button, Reset Button
Low-level peripherals	40 Pins Header, compatible with Raspberry Pi 3
uart GPIO(1x3) pin	UART, ground
LED	Power led & Status led
IR	nope
Supported OS	Android, Ubuntu, Debian, Rasberry Pi Image
Product size	65mm × 30mm
Weight	35g

BPI-M2 Zero Pin define

Banana Pi BPI-M2 Zero 40-pin GPIO define is same as BPI-M2+

Banana Pi BPI-M2 Zero has a 40-pin GPIO header that matches that of the Model 3 Raspberry Pi. Following is the Banana Pi GPIO Pinout:



	GPIO Pin Name	Default Function	Function2 : GPIO	Function3
	CON2-P01	VCC-3V3		
	CON2-P02	VCC-5V		
	CON2-P03	TWI0-SDA	PA12-EINT12	
	CON2-P04	VCC-5V		
	CON2-P05	TWI0-SCK	PA11-EINT11	
	CON2-P06	GND		
	CON2-P07	PWM1	PA6-EINT6	
	CON2-P08	UART3-TX	PA13-EINT13	SPI1-CS
	CON2-P09	GND		
	CON2-P10	UART3-RX	PA14-EINT14	SPI1-CLK
	CON2-P11	UART2-RX	PA1-EINT1	
	CON2-P12	UART3-CTS	PA16-EINT16	SPI1-MISO
	CON2-P13	UART2-TX	PA0-EINT0	
	CON2-P14	GND		
	CON2-P15	UART2-CTS	PA3-EINT3	
	CON2-P16	UART3-RTS	PA15-EINT15	SPI1-MOSI
	CON2-P17	VCC-3V3		
	CON2-P18	PC4	PC4	
	CON2-P19	SPI0-MOSI	PC0	
	CON2-P20	GND		
	CON2-P21	SPI0-MISO	PC1	
	CON2-P22	UART2-RTS	PA2-EINT2	
	CON2-P23	SPI0-CLK	PC2	
	CON2-P24	SPI0-CS	PC3	
	CON2-P25	GND		
	CON2-P26	PC7	PC7	
	CON2-P27	TWI1-SDA	PA19-EINT19	
	CON2-P28	TWI1-SCK	PA18-EINT18	
	CON2-P29	PA7-EINT7	PA7-EINT7	
	CON2-P30	GND		

	CON2-P31	PA8-EINT8	PA8-EINT8	
	CON2-P32	PL2-S-EINT2	PL2-S-EINT2	
	CON2-P33	PA9-EINT9	PA9-EINT9	
	CON2-P34	GND		
	CON2-P35	PA10-EINT10	PA10-EINT10	
	CON2-P36	PL4-S-EINT4	PL4-S-EINT4	
	CON2-P37	PA17-EINT17	PA17-EINT17	SPDIF-OUT
	CON2-P38	PA21-EINT21	PA21-EINT21	
	CON2-P39	GND		
CON2-P40	PA20-EINT20	PA20-EINT20		

CSI Camera Connector specification:

The CSI Camera Connector is a 24-pin FPC connector which can connect external camera module with proper signal pin mappings. The pin definitions of the CSI interface are shown as below. This is marked on the Banana Pi board as "CSI".

	CSI Pin Name	Default Function	Function2 : GPIO
	CN3-P01	NC	
	CN3-P02	GND	
	CN3-P03	CSI0-SDA	PE13
	CN3-P04	CSI0-AVDD	
	CN3-P05	CSI0-SCK	PE12
	CN3-P06	CSI0-Reset	PE14
	CN3-P07	CSI0-VSYNC	PE3
	CN3-P08	CSI0-PWDN	PE15
	CN3-P09	CSI0-HSYNC	PE2
	CN3-P10	CSI0-DVDD	
	CN3-P11	CSI0-DOVDD	
	CN3-P12	CSI0-D7	PE11
	CN3-P13	CSI0-MCLK	PE1
	CN3-P14	CSI0-D6	PE10
	CN3-P15	GND	
	CN3-P16	CSI0-D5	PE9
	CN3-P17	CSI0-PCLK	PE0
	CN3-P18	CSI0-D4	PE8
	CN3-P19	CSI0-D0	PE4
	CN3-P20	CSI0-D3	PE7
	CN3-P21	CSI0-D1	PE5
	CN3-P22	CSI0-D2	PE6
	CN3-P23	GND	
CN3-P24	CSI0-DOVDD		

UART specification:

The jumper CON3 is the UART interface. For developers of Banana Pi, this is an easy way to get the UART console output to check the system status and log message.

	CON3 Pin Name	Default Function	GPIO
	CON3 P03	UART0-TXD	PA4
	CON3 P02	UART0-RXD	PA5
CON3 P01	GND		

BPI-M2 Zero SD card slot

BPI-M2 Zero have support a TF card slot. same size as Raspberry pi Zero W
you can burn image to TF card ,and use it boot BPI-M2+ same as raspberry pi.

Note:

- support 8G 16G 32G 64G
- please choose class 10 TF card for banana pi.

BPI-M2 Zero WIFI interface

BPI-M2 Zero support AP6212 wifi module on board.used. it support 802.11/b/g/n wifi.

test report ,please see: 5.2 BPI-M2+ wifi Lab test

about AP6212 wifi&BT module spec:

http://wiki.friendlyarm.com/wiki/images/5/57/AP6212_V1.1_09022014.pdf

BPI-M2 Zero bluetooth interface

BPI-M2 Zero have AP6212 WiFi&Bluetooth on board.same as BPI-M2+. it support bluetooth function by defaults.

BPI-M2+ wifi antenna slot

banana pi BPI-M2 Zero have support ap6212 wifi&BT module onboard

BPI-M2 Zero have wifi antenna slot on board, the antenna slot spec same as BPI-M2+

wifi extend antenna slot spec:

RECOMMENDED PCB LAYOUT

NOTE: UNLESS OTHERWISE SPECIFIED
 1. DIMENSION SHALL BE INTERPRETED PER ANSI Y14.5M-1994.
 2. DIMENSION MARKED WITH "▼" SHOULD SPECIFIED ON INSPECTION PLAN.
 3. CONTACT RETENTION FORCE: 0.4 N MIN.
 4. CONTACT MATERIAL: COPPER ALLOY.
 5. INSULATOR: HIGH TEMPERATURE PLASTIC UL94 V-0.
 6. CONTACT FINISH: GOLD PLATED 5u" ON MATING AREAS, GOLD FINISH 1u" ON SHELL, ALL OVER 50u" NICKEL UNDER PLATED.
 7. ALL MATERIAL MEET RoHS SPECIFICATION AND IN CONFORMITY WITH REACH & SVHC STANDARD STIPULATIONS.

ITEM	PART NUMBER	DESCRIPTION	Q'TY
3	GROUND PAD	METAL SHELL, GOLD/BRIGHT GOLD PLATING	1
2	CENTER PIN	CENTER CNT, GOLD/BRIGHT GOLD PLATING	1
1	HOUSING	OVER MOLD HOUSING, LCP, IVORY, UL94V-0	1

TOLERANCES		DWN 108/08/17	
X ±0.50	XX ±0.15	ERIC	
X ±0.25	XXX ±0.10	CHECK	MICHAEL
ANGLES 8:2°		APPD	MICHAEL
TITLE		RF RECEPTACLE(U.FL)	
DWG NO.		635004802	
FINISH	SCALE	UNITS	SHEET
	1:1	mm	1 OF 1
			A# 0

so you can use 3DB/5DB wifi antenna on BPI-M2+

BPI-M2 Zero RJ45 PIN:

BPI-M2 Zero Network interface PIN define , you can contact RJ45 port.

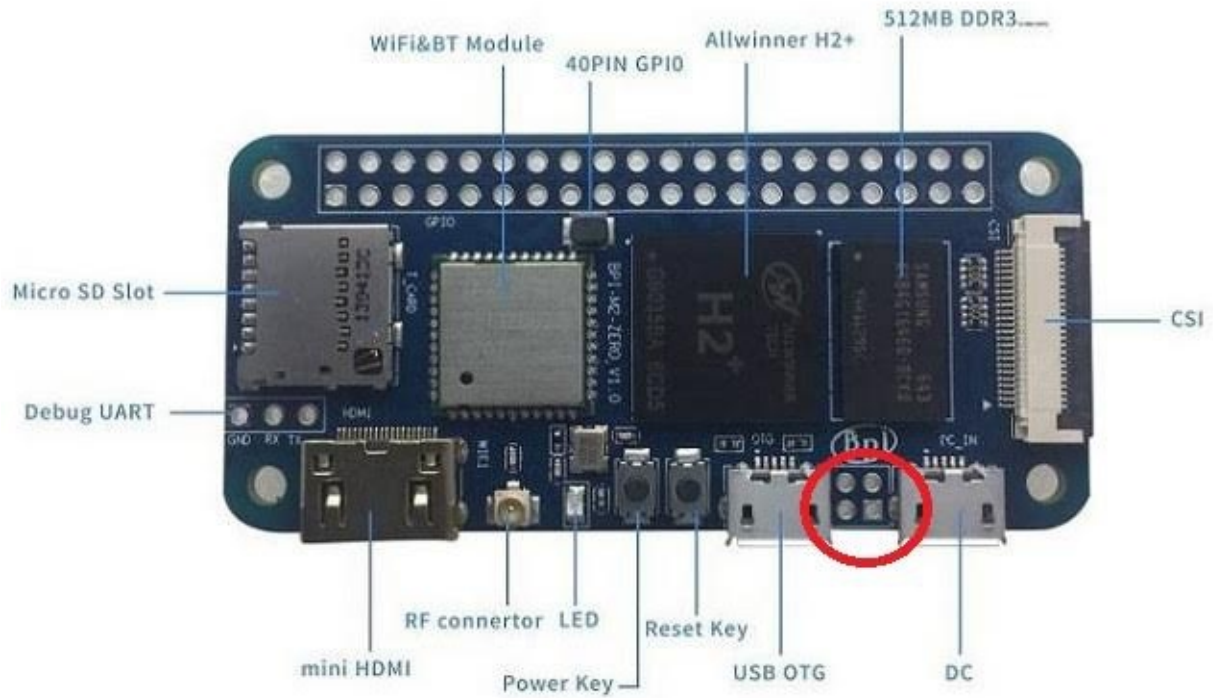

PIN define:

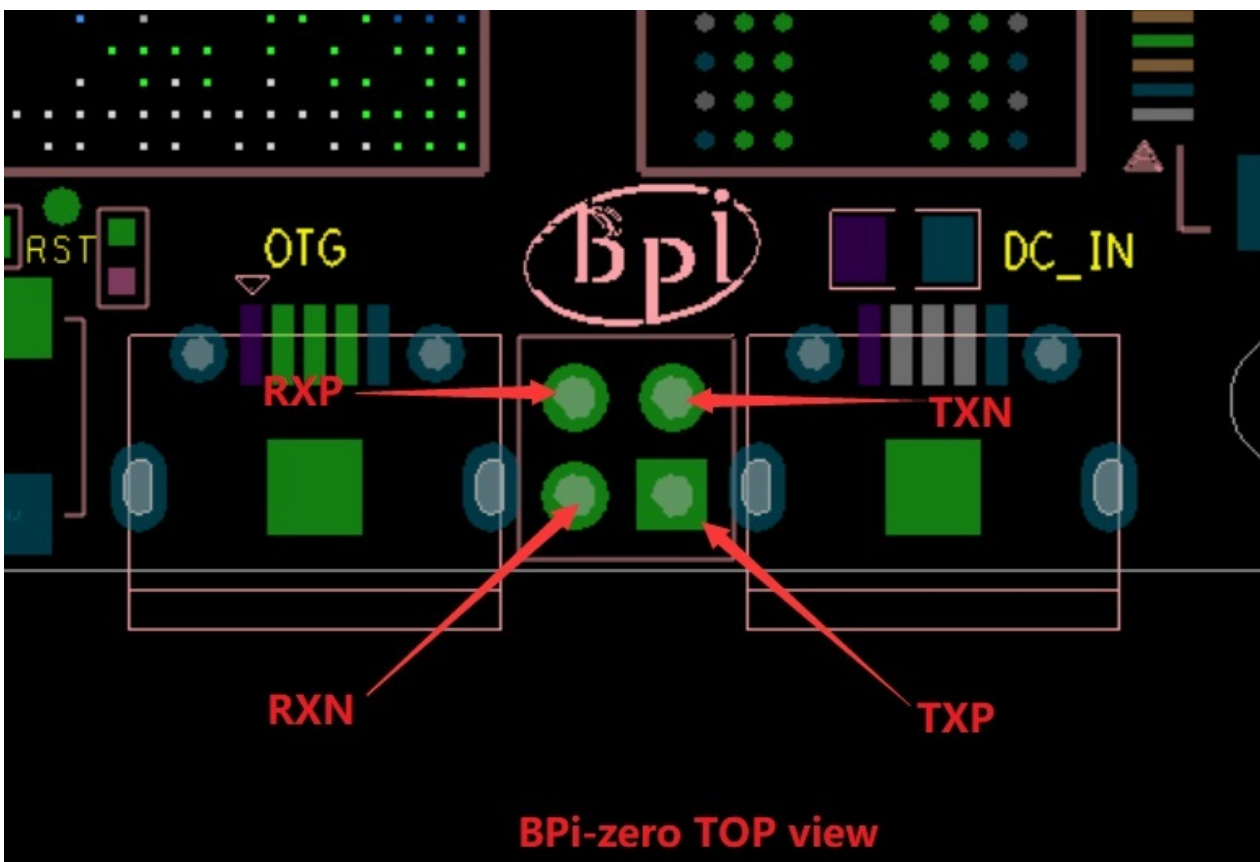

schematic:

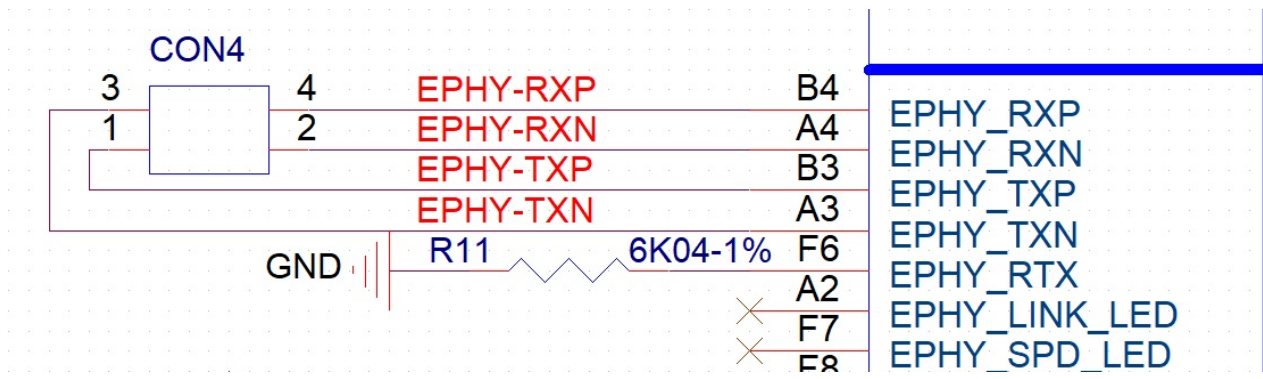

BPI-M2 Zero Mini HDMI interfact

BPI-M2 Zero has a Mini HDMI interface same as Raspberry pi Zero W.

so We can use Mini HDMI-to-HDMI cable to connect BPI-M2 Zero to the display monitor that has HDMI interface.

BPI-M2 Zero OTG interface

banana pi BPI-M2 Zero have 1 OTG port on board.

BPI-M2 Zero OTG port also can power BPI-M2 Zero, just use 5V/2A micro USB interface adapter.

so ,you can use DC port or OTG port to power BPI-M2 Zero

BPI-M2 Zero UART

Banana pi BPI-M2 Zero UART schematic diagram:

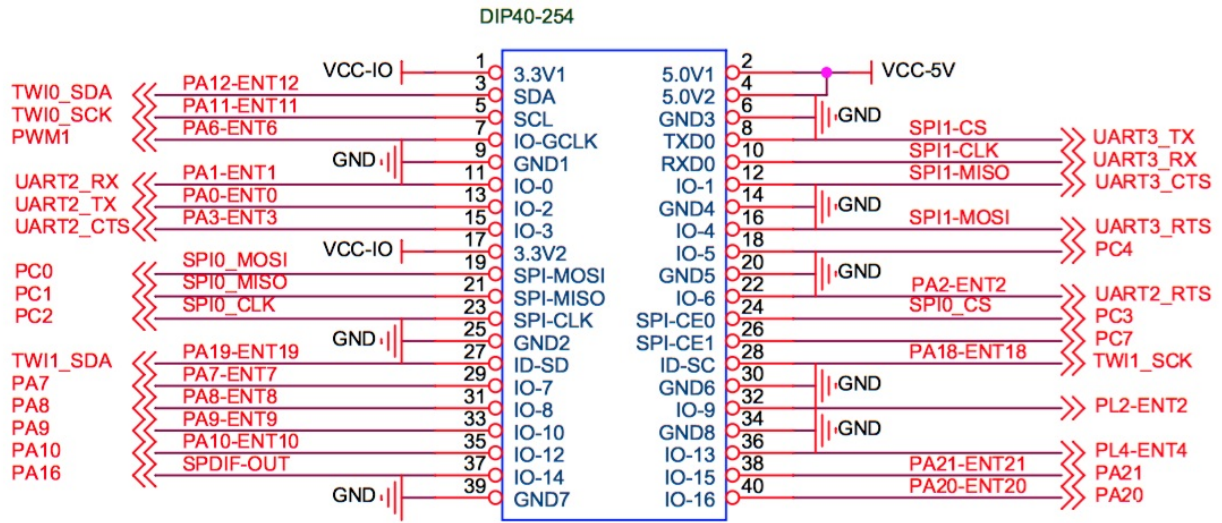

BPI-M2 Zero support 4 UART port

UART0 debug port

UART1 connect BT module

UART2 extend serial port

UART3 traditional serial port

use minicom to test UART same as BPI-M2+

BPI-M2 Zero CSI camera interface

connect external camera module with proper signal pin mappings. The pin definitions of the CSI interface are shown as below. This is marked on the Banana Pi board as "CSI".

CSI pin define:

please see: BPI-M2 Zero GPIO pine define, all is same as BPI-M2+

BPI-M2 Zero CSI camera accessories

note: for BPI-M2 Zero , camera is not same as BPI-M2,BPI-M1.... , it support OV5640 module, not need extend board. you just can direct use OV5640 modue on CSI interface.

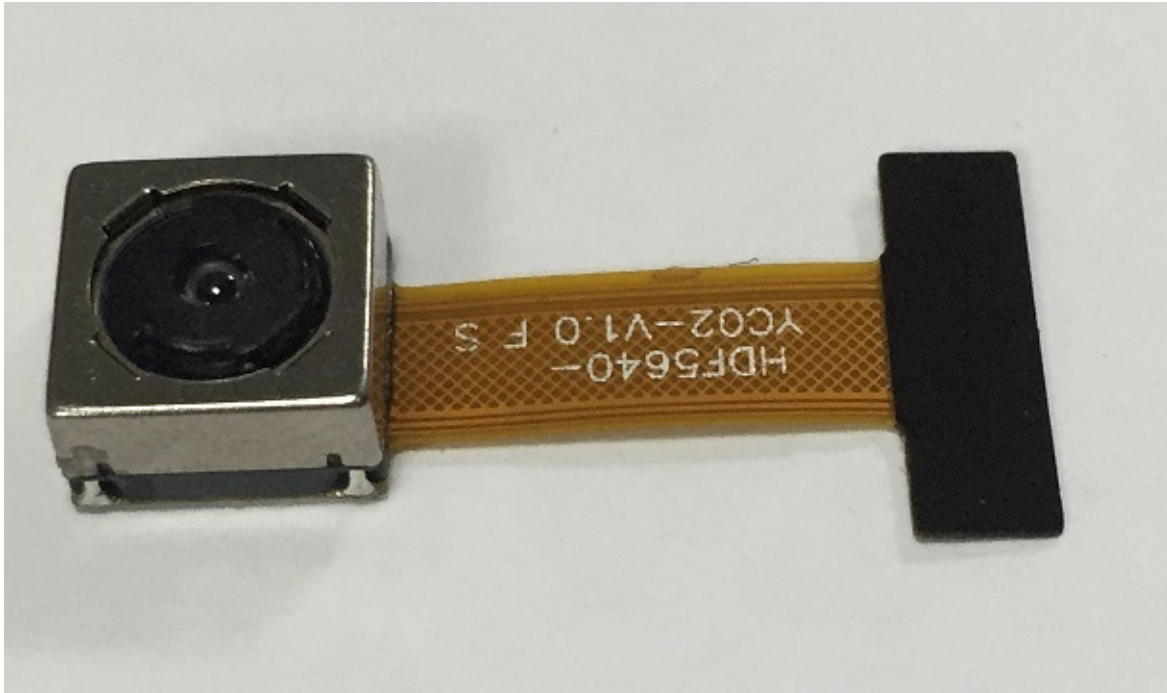

OV5640 driver:

This is my modified OV5640 driver for the CMOS camera that incorporates many image resolutions and/or image quality. You can take advantage of a higher FPS, Image Quality (Preview or Capture) or Window size, choosing the one that best fit your needs.

This is expected to work with reasonable quality for AW platform (32 bit and 64 bit).

Working window sizes and expected FPS (preview mode)

- QSXGA: 2592x1936 (7.5 FPS)
- QXGA: 2048x1536 (7.5 FPS)
- 1080P: 1920x1080 (7.5 FPS, 15 FPS)
- UXGA: 1600x1200 (7.5 FPS, 15 FPS)
- UXGA: 1280x960 (7.5 FPS, 15 FPS)
- 720P: 1280x720 (7.5 FPS, 15 FPS)
- XGA: 1024x768 (7.5 FPS, 15 FPS)
- SVGA: 800x600 (15 FPS, 30 FPS)
- VGA: 640x480 (15 FPS, 30 FPS)
- QVGA: 320x240 (30 FPS)
- QCIF: 176x144 (30 FPS with some artifacts)

link:

<https://github.com/avafinger/ov5640>

from Alex of camera developer., thank Alex do this cool work.

BPI-M2 Zero schematic diagram

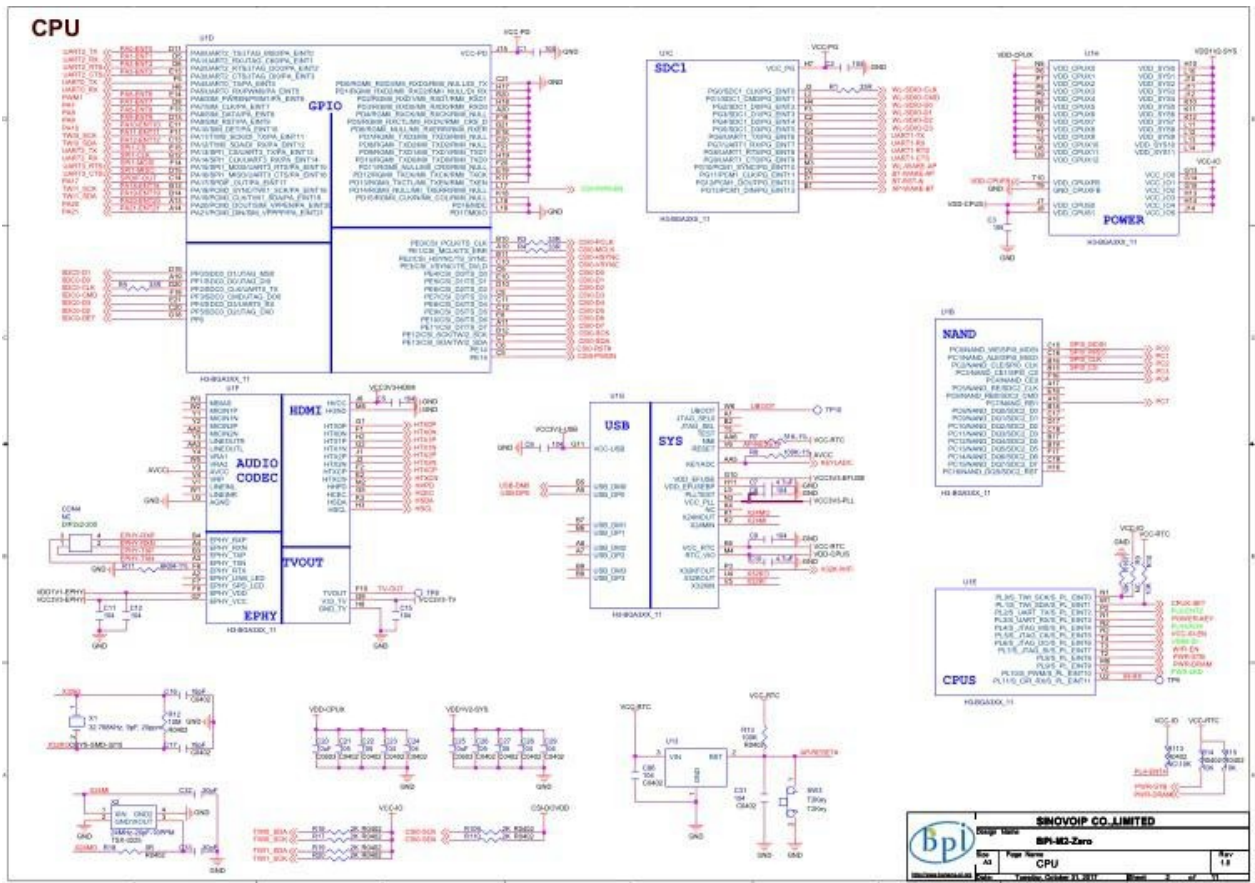

download link:

<https://drive.google.com/file/d/0B4PAo2nW2KfnMW5sVxkWSW9qa28/view?usp=sharing>

First Look BPI-M2+

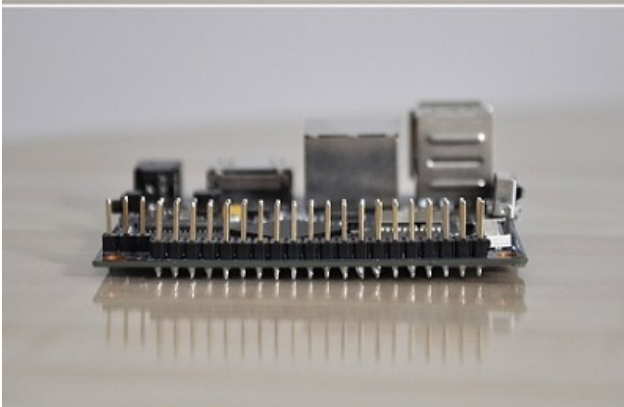
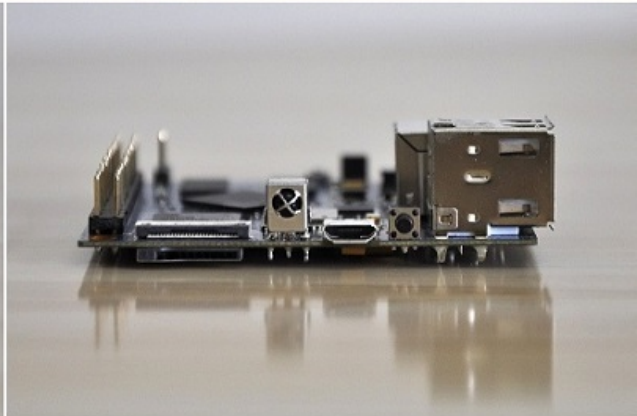

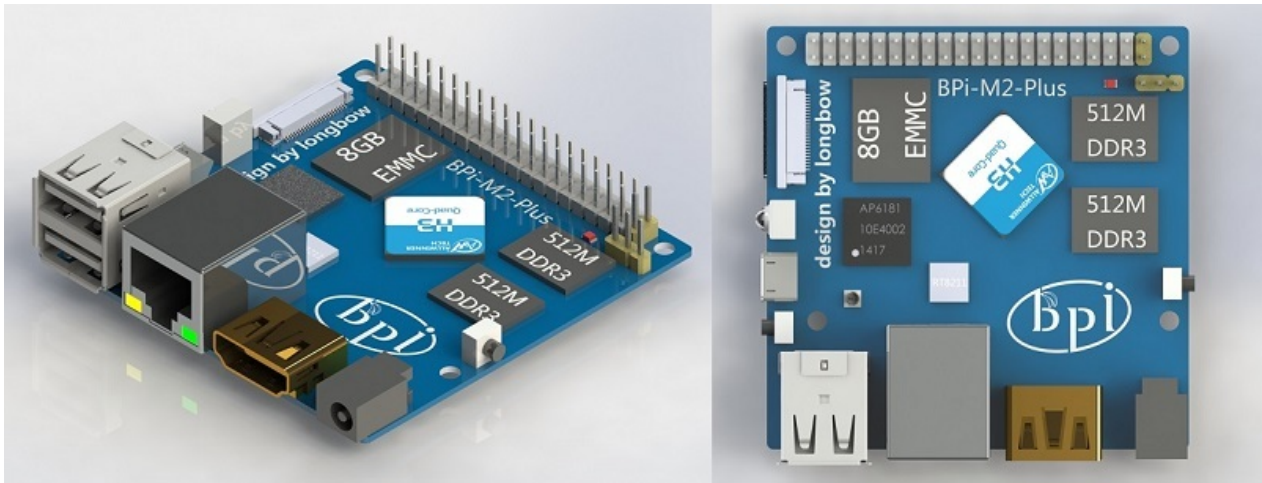

BPI-M2+ Edu version:

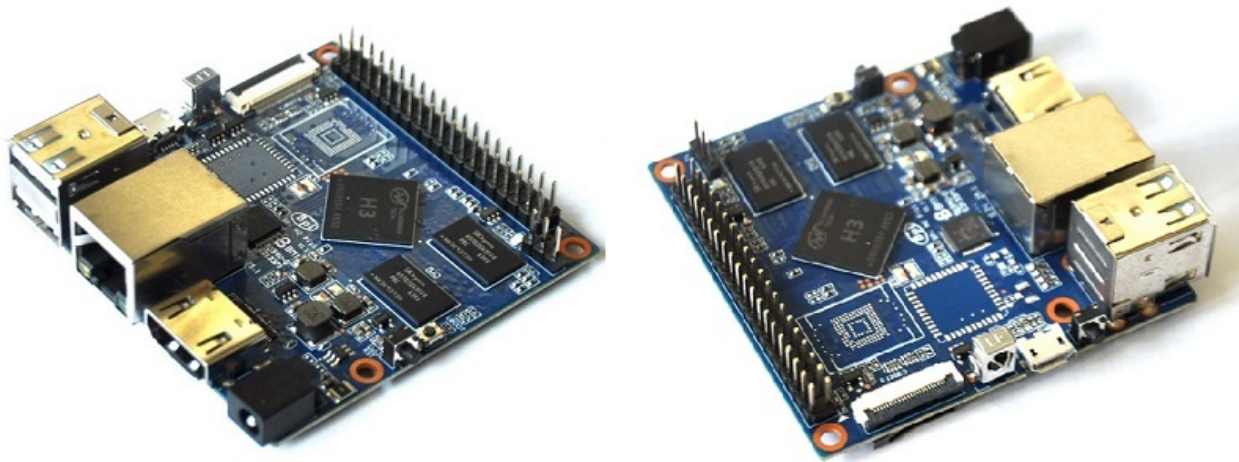

- 1,DDR form 1G to 512M
- 2,eMMC flash remove
- 5,WIFI&BT module remove.

other all is same as BPI-M2+.

Allwinner H2+ and allwinner H5 chip version:

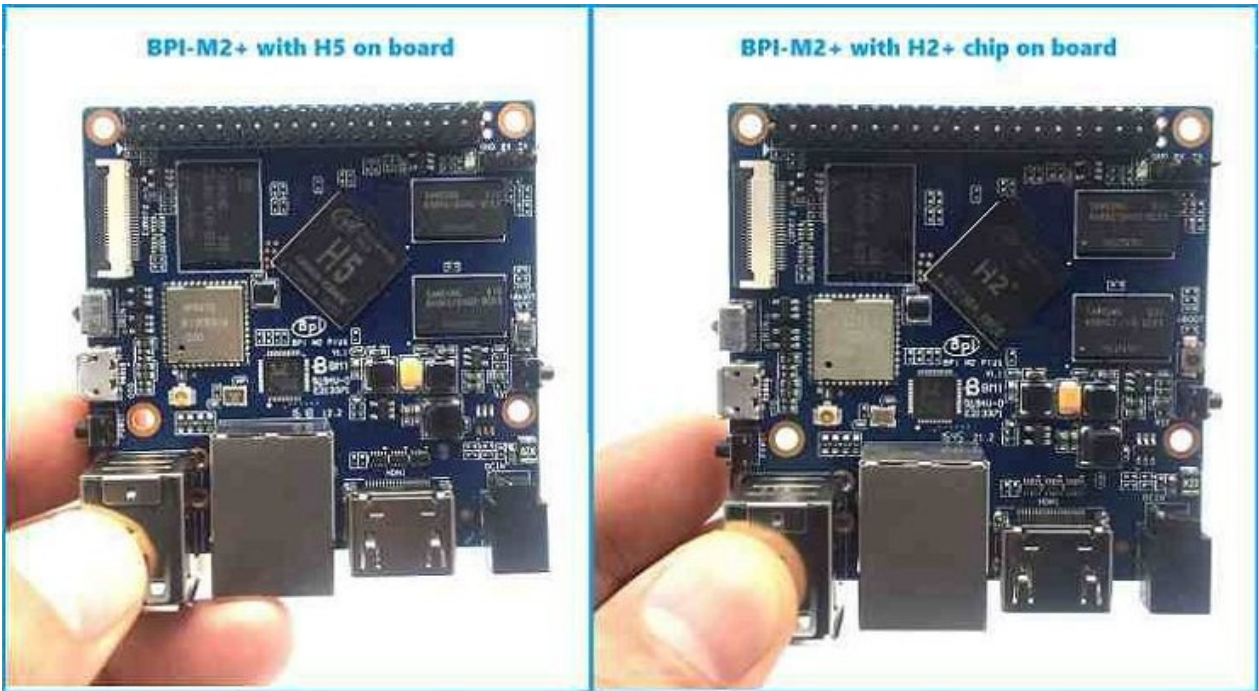

BPI-M2+ hardware interface

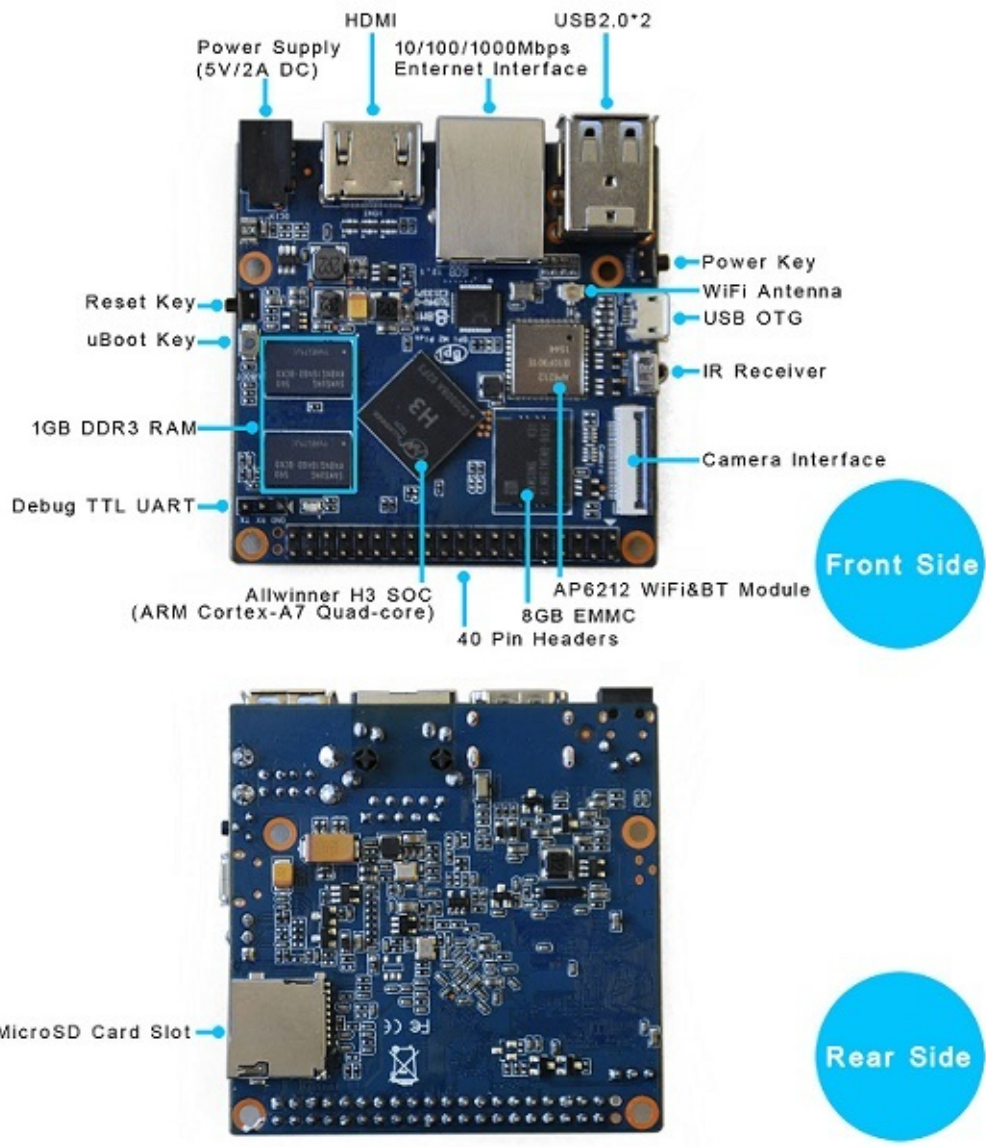

BPI-M2+ Edu hardware interface

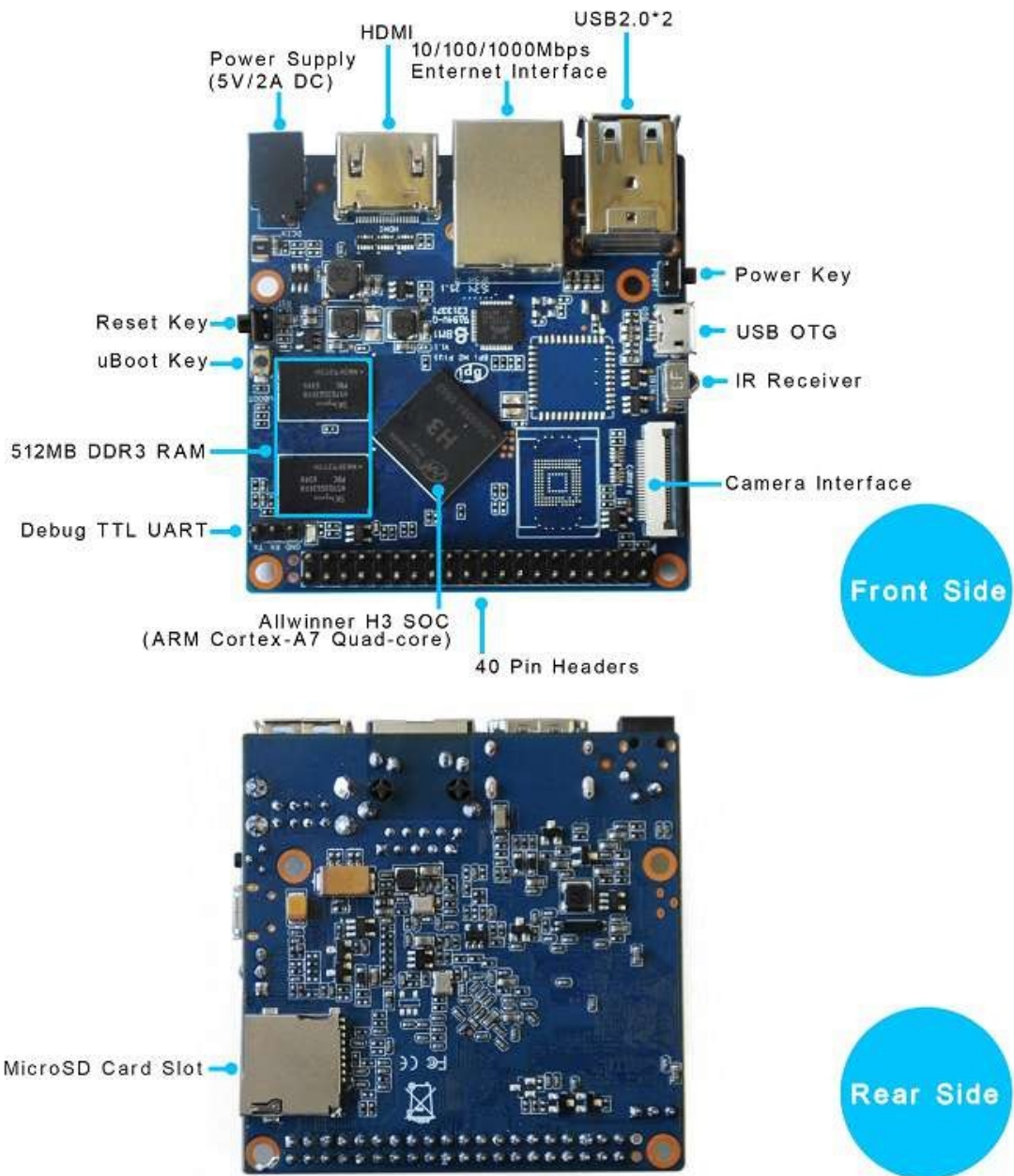

BPI-M2+ (BPI-M2 plus) hardware spec

Hardware specification

CPU	H3 Quad-core Cortex-A7 H.265/HEVC 4K
GPU	Mali400MP2 GPU @600MHz, Supports OpenGL ES 2.0
Memory (SDRAM)	1GB DDR3 (shared with GPU)
Onboard Storage	TF card (Max. 64GB) / MMC card slot, up to 2T on 2.5 SATA disk, 8GB EMMC Flash
Onboard Network	10/100/1000M Ethernet RJ45
Onboard WIFI	SDIO AP6212 (option AP6181 \ AP6335)
Video Input	A CSI input connector Camera: 1 Supports 8-bit YUV422 CMOS sensor interface, 2 Supports CCIR656 protocol for NTSC and PAL, 3 Supports SM pixel camera sensor, 4 Supports video capture solution up to 1080p@30fps
Video Outputs	Supports HDMI output with HDCP, Supports HDMI CEC, Supports HDMI 30 function, Integrated CVBS, Supports simultaneous output of HDMI and CVBS
Audio Output	HDMI
Power Source	DC input can supply power, but USB OTG input don't supply power
USB 2.0 Ports	two USB 2.0 HOST, one USB 2.0 OTG
Buttons	Power Button, Recovery Button, Uboot Button
Low-level peripherals	40 Pins Header, compatible with Raspberry Pi B+
uart GPIO(1x3) pin	UART, ground
LED	Power led & Status led
IR	IR input on board
Supported OS	Android, Ubuntu, Debian, Raspberry Pi Image
Product size	65mm × 65mm
Weight	48g

BPI-M2+ Pin define

Banana Pi BPI-M2+ 40-pin GPIO

Banana Pi BPI-M2+ has a 40-pin GPIO header that matches that of the Model B+ Raspberry Pi. Following is the Banana Pi GPIO Pinout:

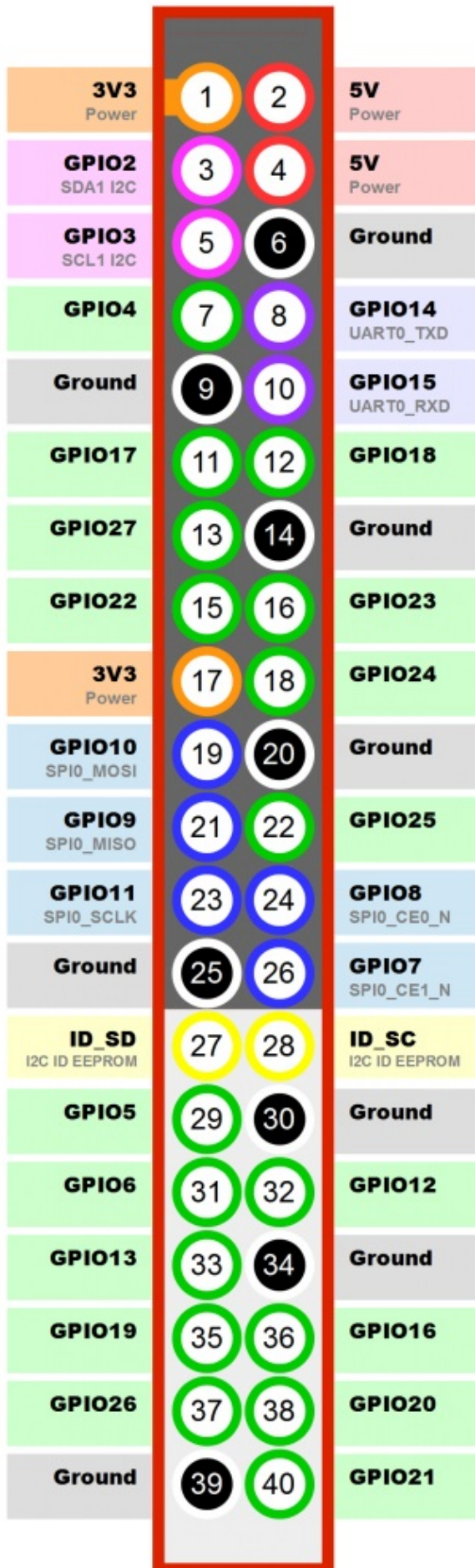

<http://www.banana-pi.org>

	GPIO Pin Name	Default Function	Function2 : GPIO	Function3
	CON2-P01	VCC-3V3		
	CON2-P02	VCC-5V		
	CON2-P03	TWI0-SDA	PA12-EINT12	
	CON2-P04	VCC-5V		
	CON2-P05	TWI0-SCK	PA11-EINT11	
	CON2-P06	GND		
	CON2-P07	PWM1	PA6-EINT6	
	CON2-P08	UART3-TX	PA13-EINT13	SPI1-CS
	CON2-P09	GND		
	CON2-P10	UART3-RX	PA14-EINT14	SPI1-CLK
	CON2-P11	UART2-RX	PA1-EINT1	
	CON2-P12	UART3-CTS	PA16-EINT16	SPI1-MISO
	CON2-P13	UART2-TX	PA0-EINT0	
	CON2-P14	GND		
	CON2-P15	UART2-CTS	PA3-EINT3	
	CON2-P16	UART3-RTS	PA15-EINT15	SPI1-MOSI
	CON2-P17	VCC-3V3		
	CON2-P18	PC4	PC4	
	CON2-P19	SPI0-MOSI	PC0	
	CON2-P20	GND		
	CON2-P21	SPI0-MISO	PC1	
	CON2-P22	UART2-RTS	PA2-EINT2	
	CON2-P23	SPI0-CLK	PC2	
	CON2-P24	SPI0-CS	PC3	
	CON2-P25	GND		
	CON2-P26	PC7	PC7	
	CON2-P27	TWI1-SDA	PA19-EINT19	
	CON2-P28	TWI1-SCK	PA18-EINT18	
	CON2-P29	PA7-EINT7	PA7-EINT7	
	CON2-P30	GND		
	CON2-P31	PA8-EINT8	PA8-EINT8	
	CON2-P32	PL2-S-EINT2	PL2-S-EINT2	
	CON2-P33	PA9-EINT9	PA9-EINT9	
	CON2-P34	GND		
	CON2-P35	PA10-EINT10	PA10-EINT10	
	CON2-P36	PL4-S-EINT4	PL4-S-EINT4	

	CON2-P37	PA17-EINT17	PA17-EINT17	SPDIF-OUT
	CON2-P38	PA21-EINT21	PA21-EINT21	
	CON2-P39	GND		
CON2-P40	PA20-EINT20	PA20-EINT20		

CSI Camera Connector specification:

The CSI Camera Connector is a 24-pin FPC connector which can connect external camera module with proper signal pin mappings. The pin definitions of the CSI interface are shown as below. This is marked on the Banana Pi board as “CSI”.

	CSI Pin Name	Default Function	Function2 : GPIO
	CN3-P01	NC	
	CN3-P02	GND	
	CN3-P03	CSI0-SDA	PE13
	CN3-P04	CSI0-AVDD	
	CN3-P05	CSI0-SCK	PE12
	CN3-P06	CSI0-Reset	PE14
	CN3-P07	CSI0-VSYNC	PE3
	CN3-P08	CSI0-PWDN	PE15
	CN3-P09	CSI0-HSYNC	PE2
	CN3-P10	CSI0-DVDD	
	CN3-P11	CSI0-DOVDD	
	CN3-P12	CSI0-D7	PE11
	CN3-P13	CSI0-MCLK	PE1
	CN3-P14	CSI0-D6	PE10
	CN3-P15	GND	
	CN3-P16	CSI0-D5	PE9
	CN3-P17	CSI0-PCLK	PE0
	CN3-P18	CSI0-D4	PE8
	CN3-P19	CSI0-D0	PE4
	CN3-P20	CSI0-D3	PE7
	CN3-P21	CSI0-D1	PE5
	CN3-P22	CSI0-D2	PE6
	CN3-P23	GND	
CN3-P24	CSI0-DOVDD		

UART specification:

The jumper CON3 is the UART interface. For developers of Banana Pi, this is an easy way to get the UART console output to check the system status and log message.

	CON3 Pin Name	Default Function	GPIO
	CON3 P03	UART0-TXD	PA4
	CON3 P02	UART0-RXD	PA5
CON3 P01	GND		

BPI-M2+ SD card slot

BPI-M2+ have support a TF card slot. you can burn image to TF card ,and use it boot BPI-M2+ same as raspberry pi.



Note:

- support 8G 16G 32G 64G
- please choose class 10 TF card for banana pi.

BPI-M2+ GigE LAN

Banana PI BPI-M2+ with one Gigabit ethernet port,use RTL8211E chip on board.

BPI-M2+ eMMC flash

BPI-M2+ have support 8G eMMC flash on board by defaults.for customization user , we can add 4-64G emmc on board.

So, you can burn your image to eMMC flash and boot from eMMC flash.

How to burn Android image to eMMC

please read this book :

2.2.1 How to burn android image to eMMC

How to burn Linux image to eMMC

please read this book:

2.3.1 How to burn linux image to eMMC

Note:

the first boot is from microSD card. if you want to boot from eMMC flash ,please remove microSD card from BPI-M2+ microSD card slots.

BPI-M2+ WIFI interface

BPI-M2+ support AP6212 wifi module on board.used. it support 802.11/b/g/n wifi.

test report ,please see: 5.2 BPI-M2+ wifi Lab test

about AP6212 wifi&BT module spec:

http://wiki.friendlyarm.com/wiki/images/5/57/AP6212_V1.1_09022014.pdf

BPI-M2+ wifi antenna slot

banana pi BPI-M2+ have support ap6212 wifi&BT module onboard

BPI-M2+ have wifi antenna slot on board

wifi extend antenna slot spec:

RECOMMENDED PCB LAYOUT

NOTE: UNLESS OTHERWISE SPECIFIED

1. DIMENSION SHALL BE INTERPRETED PER ANSI Y14.5M-1994.
2. DIMENSION MARKED WITH "▼" SHOULD SPECIFIED ON INSPECTION PLAN.
3. CONTACT RETENTION FORCE: 0.4 N MIN.
4. CONTACT MATERIAL: COPPER ALLOY.
5. INSULATOR: HIGH TEMPERATURE PLASTIC UL94 V-0.
6. CONTACT FINISH: GOLD PLATED 5u" ON MATING AREAR, GOLD FINISH 1u" ON SHELL, ALL OVER 50u" NICKEL UNDER PLATED.
7. ALL MATERIAL MEET RoHS SPECIFICATION AND IN CONFORMITY WITH REACH & SVHC STANDARD STIPULATIONS.

ITEM	PART NUMBER	DESCRIPTION	Q'TY
3	GROUND PAD	METAL SHELL, GOLD/BRIGHT GOLD PLATING	1
2	CENTER PIN	CENTER CNT, GOLD/BRIGHT GOLD PLATING	1
1	HOUSING	OVER MOLD HOUSING, LCP, IVORY, UL94V-0	1

TOLERANCES		DWN 108/08/17 ERIC	
X ±0.50	XX ±0.15	CHECK	MICHAEL
X ±0.25	XXX ±0.10	APPD	MICHAEL
ANGLES 8:2		TITLE RF RECEPTACLE(U.FL)	
DWG NO. 635004802		SHEET 1 OF 1	
FINISH	SCALE 1:1	UNITS mm	SIZE REV A# 0

so you can use 3DB/5DB wifi antenna on BPI-M2+

BPI-M2+ bluetooth interface

BPI-M2+ have AP6212 WiFi&Bluetooth on board same as BPI-M3. it support bluetooth function by default.

BPI-M2+ IR interface

BPI-M2+ support IR interface on board. you can use it as remote control.

1,install lirc

```
apt-get install lirc
apt-get install evtest
```

2,edit /etc/lirc/hardware.conf as below:

```
nano /etc/lirc/hardware.conf
```

```
# /etc/lirc/hardware.conf
#
# Arguments which will be used when launching lircd
LIRCD_ARGS="--uinput"
#Don't start lircmd even if there seems to be a good config file
#START_LIRCMD=false

#Don't start irexec, even if a good config file seems to exist.
#START_IREXEC=false

#Try to load appropriate kernel modules
LOAD_MODULES=true

# Run "lircd --driver=help" for a list of supported drivers.
DRIVER="UNCONFIGURED"
# usually /dev/lirc0 is the correct setting for systems using udev
DEVICE="/dev/input/event0"
MODULES="sunxi-ir"
```

ctrl+O save and ctrl+x exit.

3,test lirc

```
service lirc start
```

```
root@bananapi ~ # service lirc start
[ ok ] No valid /etc/lirc/lircd.conf has been found..
[ ok ] Remote control support has been disabled..
[ ok ] Reconfigure LIRC or manually replace /etc/lirc/lircd.conf
```

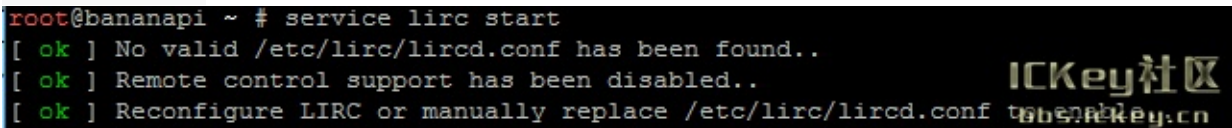

4 test remote-control unit

```
evtest
```

```
root@bananapi ~ # evtest
No device specified, trying to scan all of /dev/input/event*
Available devices:
/dev/input/event0: sunxi-ir
/dev/input/event1: axp20-supplyer
Select the device event number [0-1]:
```

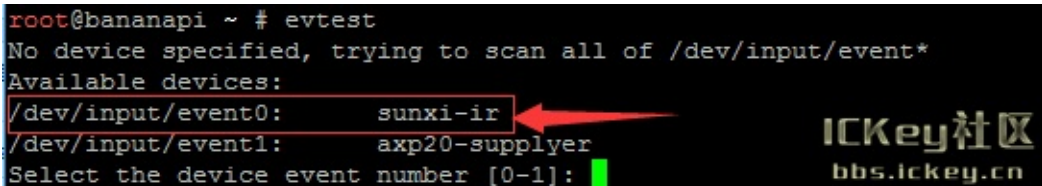

choose "0" must xunxi-ir

```

Event code 255 (?)
Properties:
Testing ... (interrupt to exit)
Event: time 1444183347.050146, type 1 (EV_KEY), code 12 (KEY_MINUS), value 1
Event: time 1444183347.050155, ----- EV_SYN -----
Event: time 1444183347.244484, type 1 (EV_KEY), code 12 (KEY_MINUS), value 0
Event: time 1444183347.244490, ----- EV_SYN -----
Event: time 1444183351.038825, type 1 (EV_KEY), code 28 (KEY_ENTER), value 1
Event: time 1444183351.038834, ----- EV_SYN -----
Event: time 1444183351.494493, type 1 (EV_KEY), code 28 (KEY_ENTER), value 0
Event: time 1444183351.494500, ----- EV_SYN -----
Event: time 1444183352.015994, type 1 (EV_KEY), code 90 (KEY_KATAKANA), value 1
Event: time 1444183352.016003, ----- EV_SYN -----
Event: time 1444183352.364482, type 1 (EV_KEY), code 90 (KEY_KATAKANA), value 1
Event: time 1444183352.364489, ----- EV_SYN -----
    
```

please note:value 0 value 1

press is:1 ↵ unpress is:0

key 64	MOUSE	WAKE
key 24	BACK	WAKE_DROPPED
key 83	VOLUME_DOWN	WAKE
key 91	VOLUME_UP	WAKE

BPI-M2+ keycode:

IR Address: 4040

1.how to do check IR address on Android.

```

echo 0xff > /sys/module/sunxi_ir_rx/parameters/debug_mask

<7>[ 625.998452] IR code = 0xf20d4040
<7>[ 625.998473] IR RAW CODE : 13
<7>[ 625.998542] IR CODE : 13
<7>[ 625.998629] IR KEY VALE 13
<7>[ 625.998653] ir_rx_irq_service: Rx Packet End, code=0xf20d4040, ir_code=0x
<6>[ 625.998717] cpus_wakeup_config_handler: address: 0x4040, powerkey: 0x0a
<6>[ 626.002717] cpus_wakeup_config_handler: ok
    
```

demo IR remote control on youtube:

https://www.youtube.com/watch?v=HhW_G85Byio&feature=youtu.be

BPI IR remoter control accessoires:

<https://bananapi.gitbooks.io/bpi-accessories/content/irremotecontrol.html>

BPI-M2+ HDMI interfact

BPI-M2+ has a standard HDMI 1.4 interface. so We can use HDMI-to-HDMI cable to connect BPI-M2+ to the display monitor that has HDMI interface.



But If the display monitor doesn't have HDMI interface,only VGA or DVI port. We should use HDMI-to-VGA or HDMI-to-DVI cable to connect the BPI-M2+ to the display monitor.



Note: if the HDMI-to-VGA/DVI cable is a bad quality cable,it will go wrong on the monitor display. please choose a good quality cable for BPI-M2+

BPI-M2+ USB interface

BPI-M2+ have two USB 2.0 interface on board.so you can connect Keyboard,mouse, USB camera and ... on BPI-M2+.

two USB connect to H3 chip ,not use USB hub function ,so is support 480M speed for each port.

BPI-M2+ OTG interface

banana pi BPI-M2+ have 1 OTG port on board.

BPI-M2+ OTG port also can power BPI-M2+, just use 5V/2A micro USB interface adapter.

so ,you can use DC port or OTG port to power BPI-M2+

BPI-M2+ CSI camera interface

connect external camera module with proper signal pin mappings. The pin definitions of the CSI interface are shown as below. This is marked on the Banana Pi board as "CSI".

CSI pin define:

please see: BPI-M2+ GPIO pine define

BPI-M2+ CSI camera accessories

note: for BPI-M2+ , camera is not same as BPI-M2,BPI-M1.... , it support OV5640 module, not need extend board. you just can direct use OV5640 modue on CSI interface.

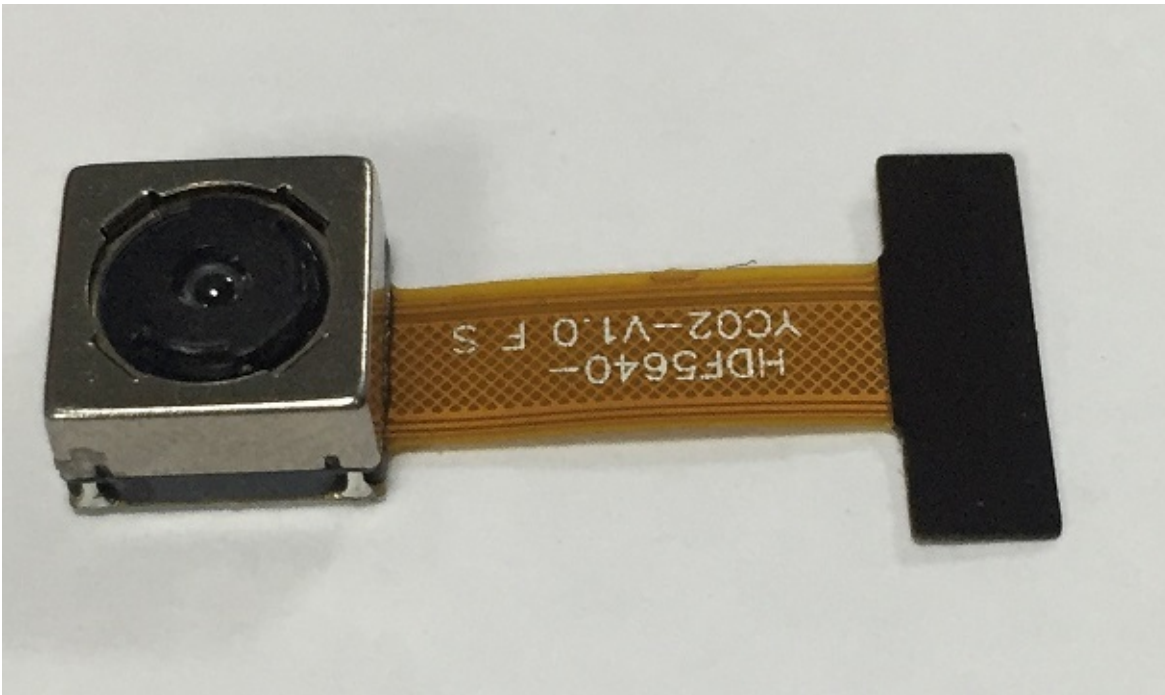

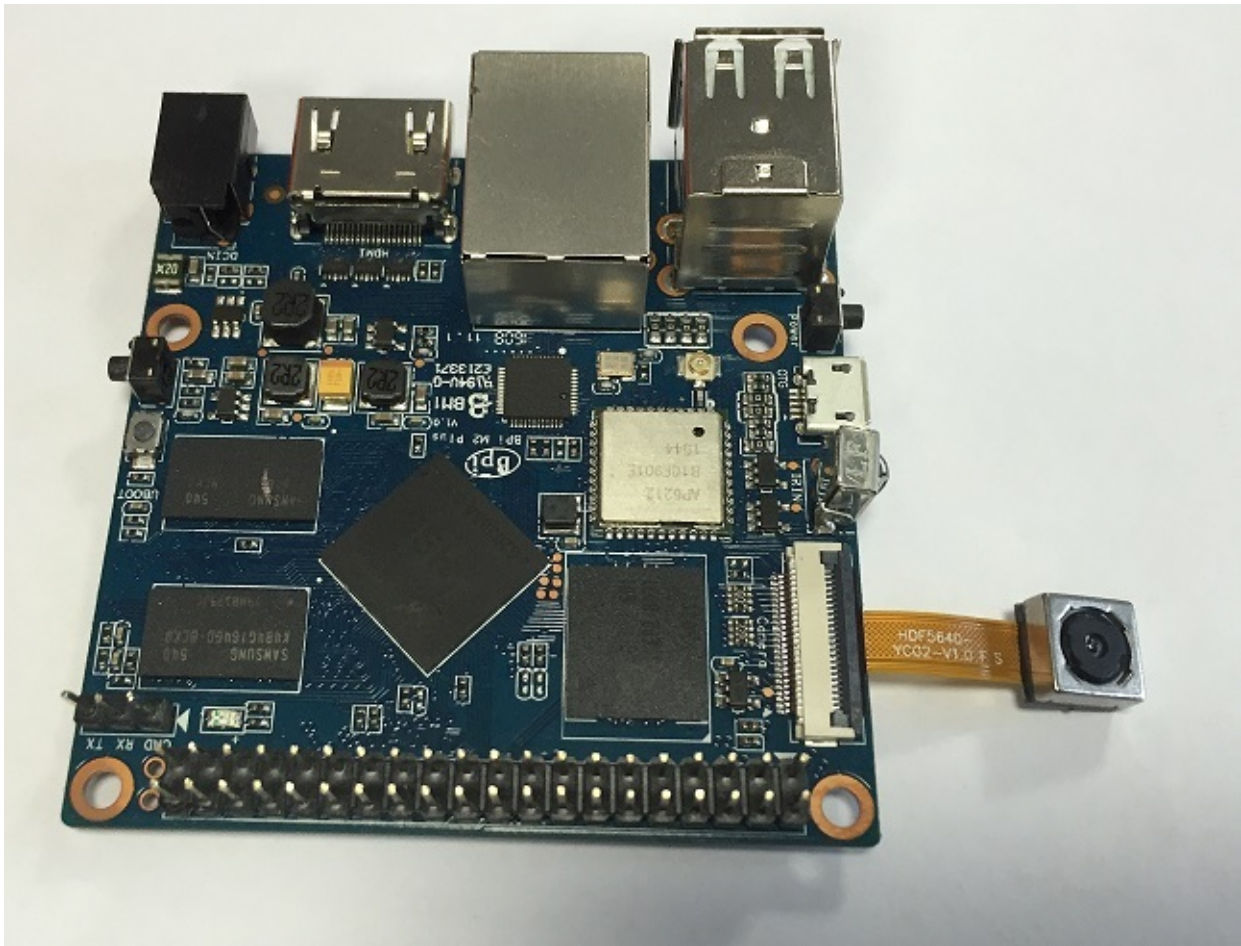

OV5640 driver:

This is my modified OV5640 driver for the CMOS camera that incorporates many image resolutions and/or image quality. You can take advantage of a higher FPS, Image Quality (Preview or Capture) or Window size, choosing the one that best fit your needs.

This is expected to work with reasonable quality for AW platform (32 bit and 64 bit).

Working window sizes and expected FPS (preview mode)

- QSXGA: 2592x1936 (7.5 FPS)
- QXGA: 2048x1536 (7.5 FPS)
- 1080P: 1920x1080 (7.5 FPS, 15 FPS)
- UXGA: 1600x1200 (7.5 FPS, 15 FPS)
- UXGA: 1280x960 (7.5 FPS, 15 FPS)
- 720P: 1280x720 (7.5 FPS, 15 FPS)
- XGA: 1024x768 (7.5 FPS, 15 FPS)
- SVGA: 800x600 (15 FPS, 30 FPS)
- VGA: 640x480 (15 FPS, 30 FPS)
- QVGA: 320x240 (30 FPS)
- QCIF: 176x144 (30 FPS with some artifacts)

link:

<https://github.com/avafinger/ov5640>

from Alex of camera developer., thank Alex do this cool work.

BPI-M2+ UART

UART schematic diagram:

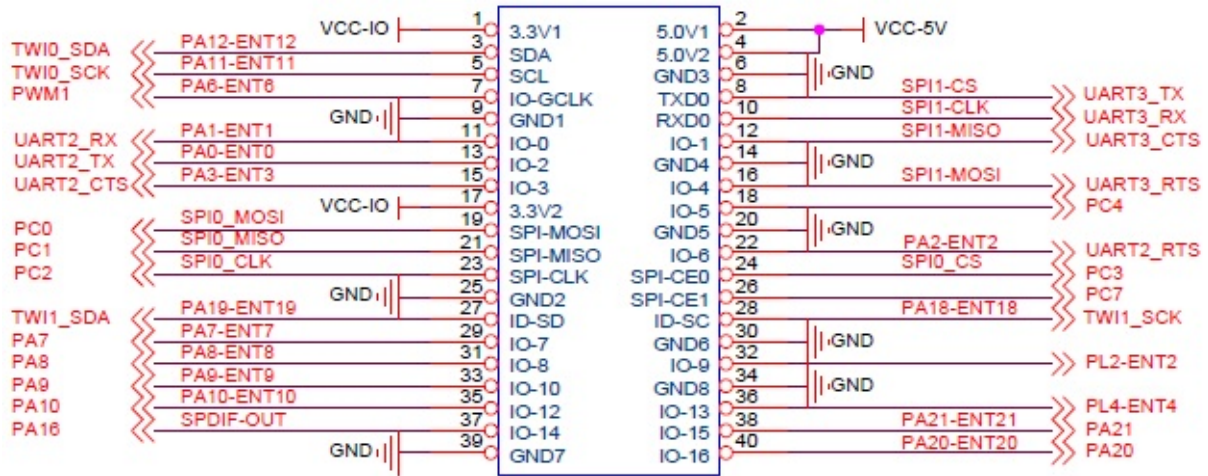

BPI-M2+ support 4 UART port

UART0 debug port UART1 connect BT module UART2 extend serial port UART3 traditional serial port

use minicom to test UART:

```
sudo apt-get install minicom
sudo minicom -s
```

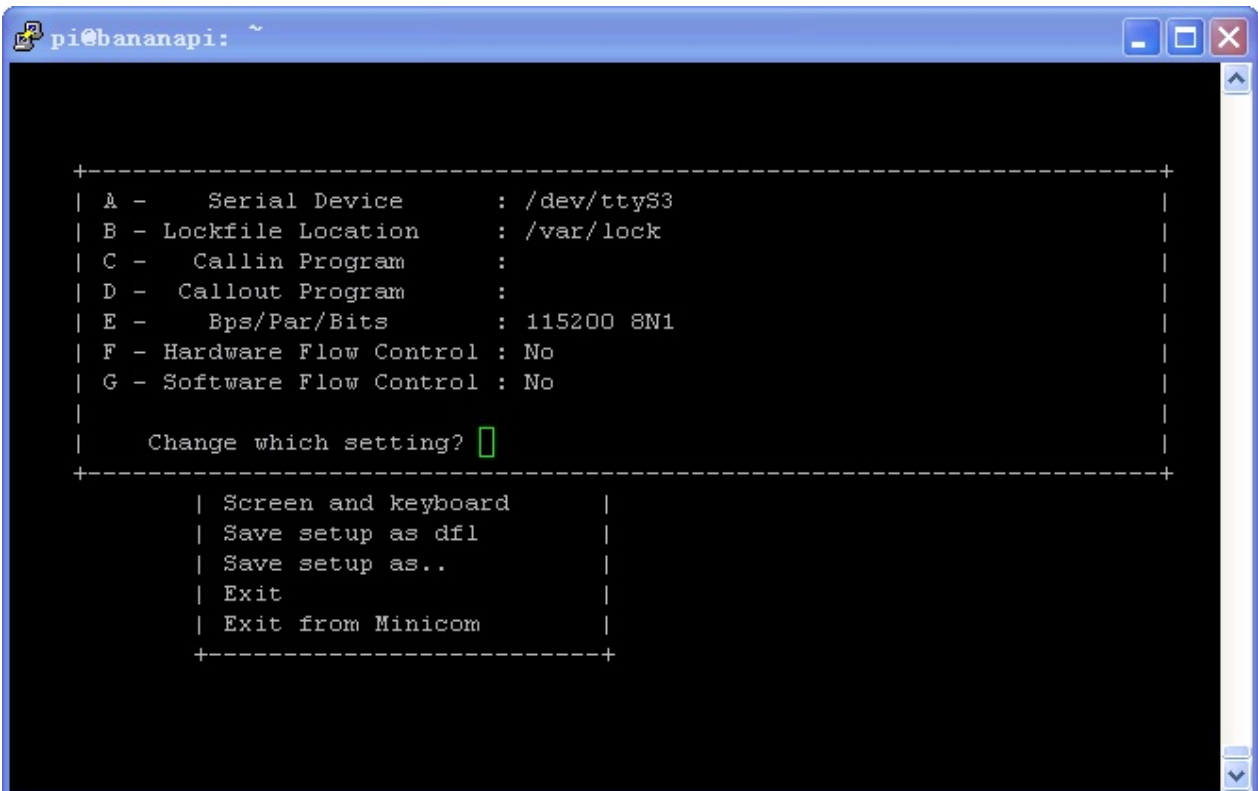

test /dev/ttyS0 、 /dev/ttyS2 、 /dev/ttyS3 loopback success

```
pi@bananapi: ~  
Welcome to minicom 2.7  
  
OPTIONS: I18n  
Compiled on Jan 12 2014, 05:42:53.  
Port /dev/ttyS0  
  
Press CTRL-A Z for help on special keys  
  
Debug Port!  
█
```

```
pi@bananapi: ~  
Welcome to minicom 2.7  
  
OPTIONS: I18n  
Compiled on Jan 12 2014, 05:42:53.  
Port /dev/ttyS2  
  
Press CTRL-A Z for help on special keys  
  
MikuQ!  
█
```

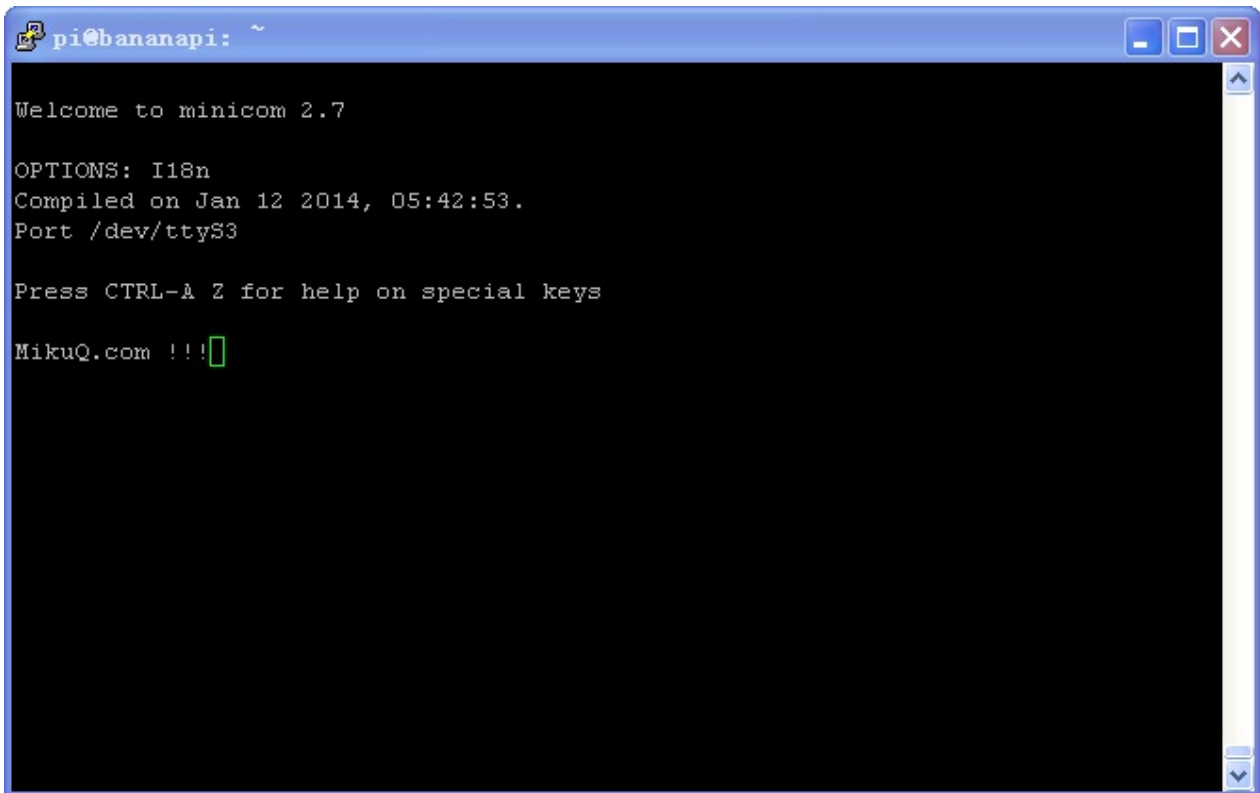
The image shows a terminal window titled "pi@bananapi: ~". The window contains the following text:

```
Welcome to minicom 2.7

OPTIONS: I18n
Compiled on Jan 12 2014, 05:42:53.
Port /dev/ttyS3

Press CTRL-A Z for help on special keys

MikuQ.com !!!
```

The terminal window has a blue title bar with standard window controls (minimize, maximize, close) on the right. A vertical scrollbar is visible on the right side of the terminal area.

BPI-M2+ Power interface

BPI-M2+ power with DC port , please use 5V/2A adapter for it.

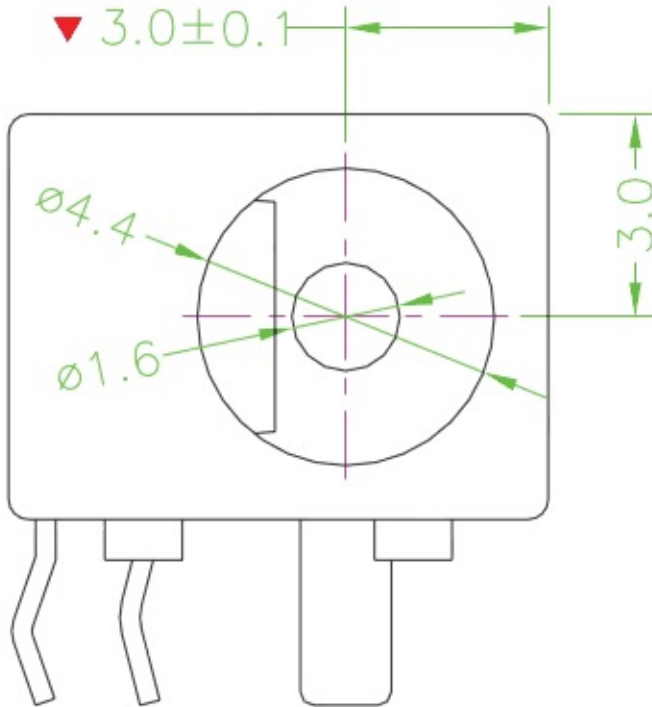

you can use same adapter with BPI-M2,BPI-M2+,BPI-M3.

BPI-M2+ OTG port also can power BPI-M2+, just use 5V/2A micro USB interface adapter.

so ,you can use DC port or OTG port to power BPI-M2+

BPI-M2+ schematic diagram

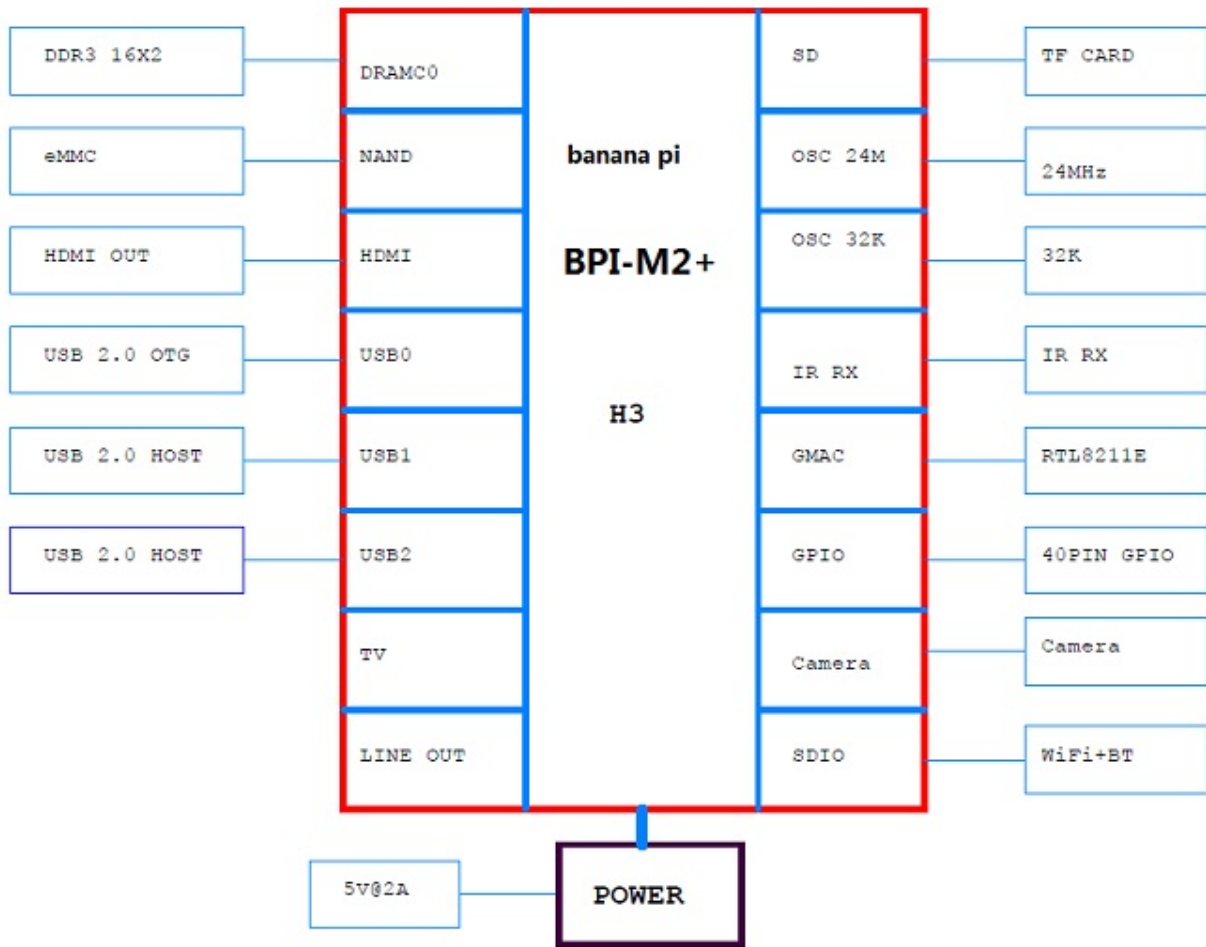

BPI-M2+ schematic diagram download link:

google driver : update at 2017-08-24

<https://drive.google.com/file/d/0B4PAo2nW2KfmbzQ5MTB5eXNEN1U/view?usp=sharing>

baidu link:

<http://pan.baidu.com/s/1bo93fWj>

BPI-M2+ DXF and 3D design

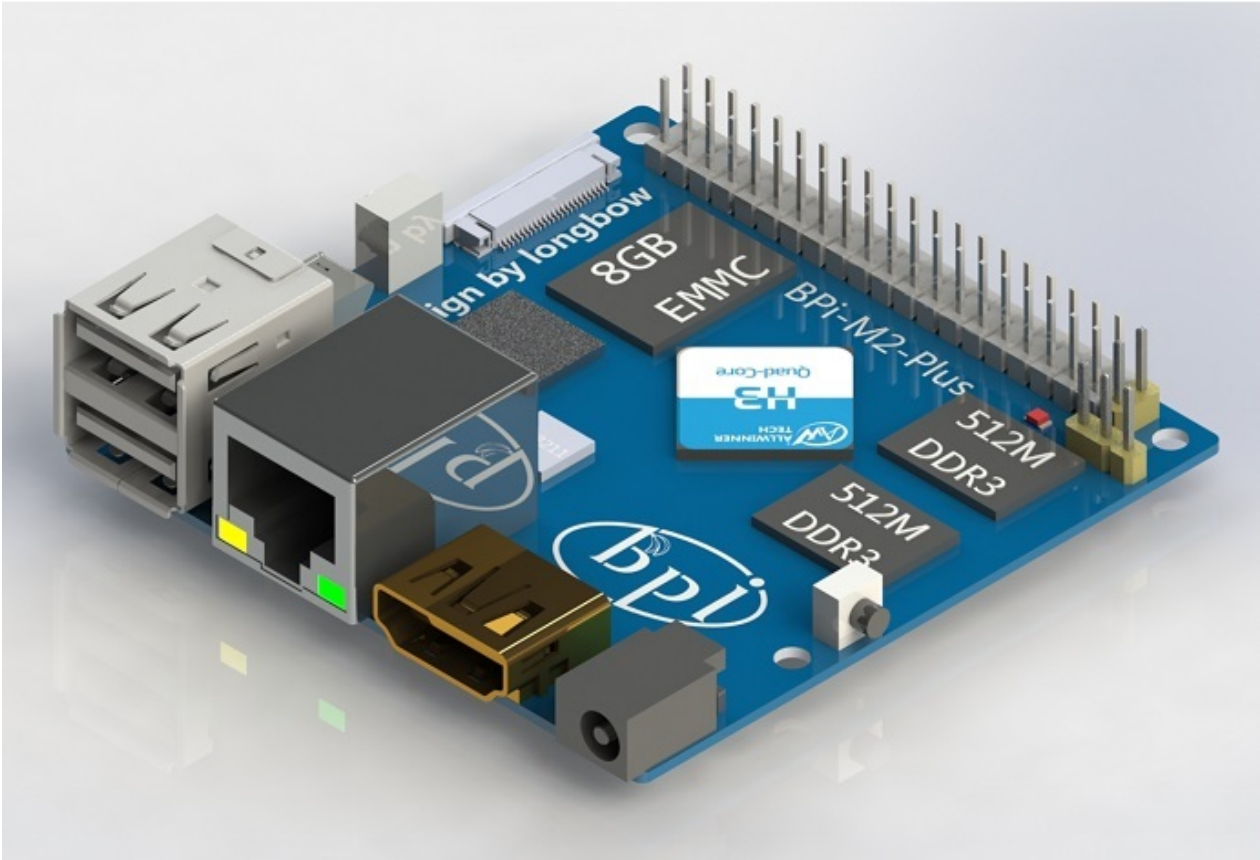

3D design front:

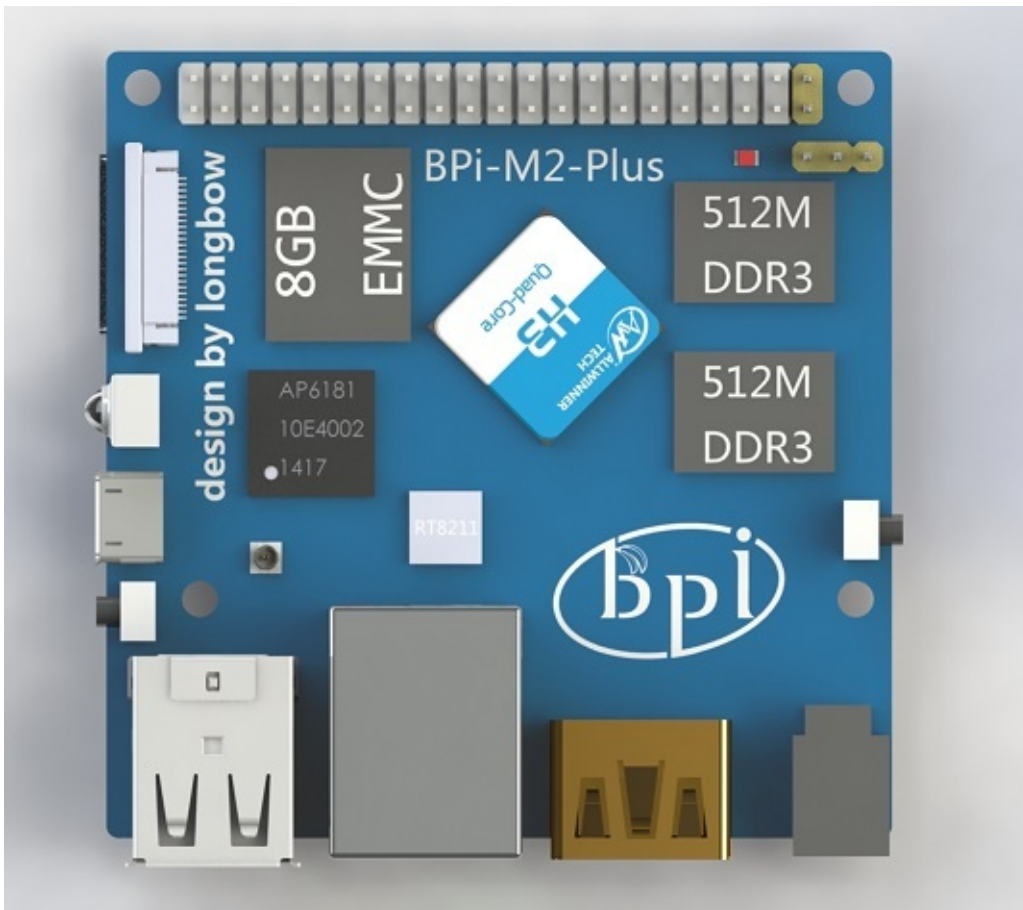

3D design back:

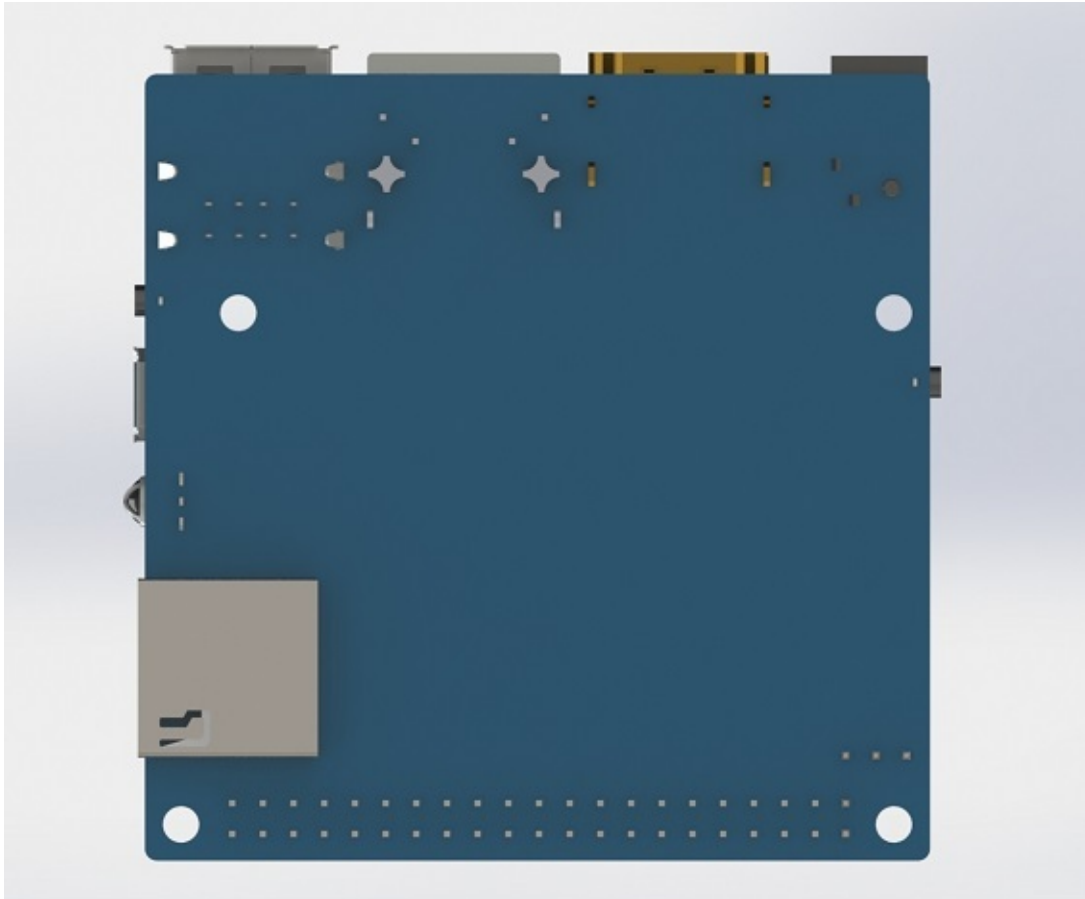

BPI-M2+ DXF file download link:

<https://drive.google.com/file/d/0B4PAo2nW2KfnaDRVLUpvV3hIVUk/view?usp=sharing>

BPI-M2 3D design file download link:

<https://drive.google.com/file/d/0B4PAo2nW2KfnVV8zaDhYazRvOU0/view?usp=sharing>

note: wifi module is AP6212, not AP6181

BPI-M2+ software

BPI-M2+ Quick Start

Step 1: Get what you need

First time to enjoy your Banana Pi, you need at least the accessories in the table below.

No.	Item	Minimum recommended specification & notes
1	MicroSD card	SD card is optional. If need to boot form SD card, Minimum size 8GB, class 10 (the class indicates how fast the card is). We recommend using branded SD cards as they are more reliable.
2	avHDMI(Full sized) to HDMI / DVI lead	HDMI to HDMI lead (for HD TVs and monitors with HDMI input).OR HDMI to DVI lead (for monitors with DVI input).
3	Keyboard and mouse	Any standard USB keyboard and mouse should work. keyboards or mice that take a lot of power from the USB ports, however, may need a powered USB hub. This may include some wireless devices.
4	Ethernet cable	Networking is optional, although it makes updating and getting new software for your Banana Pi much easier.
5	Micro USB power adapter	A good quality, USB Power supply that can provide at least 5V/2A is essential.OTG also can power the board, but it is not recommended.
6	Mobile Hard disk (Optional)	You can choose to connect a mobile hard disk to USB port to store more files.



Base you need below:

Step 2: Download the relevant Image file:

Please visit our webmaster: www.banana-pi.org to download image, banana pi all image can be download form this web.

Step3: Prepare your SD card for the Banana Pi

In order to enjoy your Banana Pi BPI-M3, you will need to install an Operating System (OS) onto an SD card or eMMC Flash. Instructions below will teach you how to write an OS image to your SD card or eMMC Flash under Windows and Linux.

1.Insert your SD card into your computer. The size of SD should be larger than the OS image size, generally 8GB or greater.

2.Format the SD card.

Format your SD under Windows os :

Download the a SD card format tool such as SD Formatter from https://www.sdcard.org/downloads/formatter_4/eula_windows/

*Unzip the download file and run the setup.exe to install the tool on your machine.

*In the "Options" menu, set "FORMAT TYPE" option to QUICK, "FORMAT SIZE ADJUSTMENT" option to "ON".

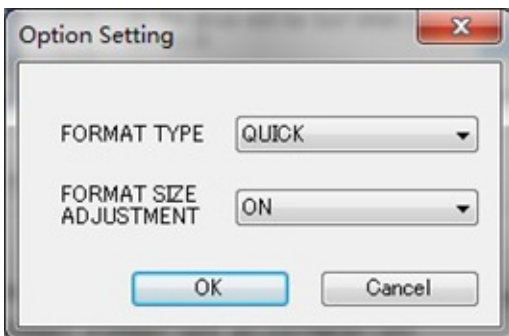
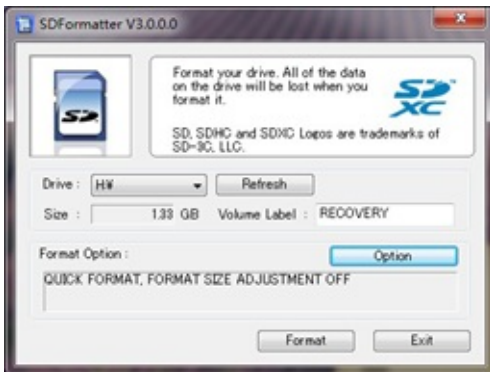

*Check that the SD card you inserted matches the one selected by the Tool.

*Click the "Format" button.

Format your SD under Linux os :

*Run `fdisk -l` command to check the SD card node.

*Run `sudo fdisk /dev/sdx` command to delete all partition of SD card.

*Run `mkfs -t vfat /dev/sdx` command to format the entire SD card as FAT. (x should be replaced according to your SD card node)

3,Download the OS image from Download district(<http://www.banana-pi.org>)

4.Unzip the download file to get the OS image.

Windows: Right click on the file and choose "Extract all".

Linux: Run unzip [downloaded filename] command.

5. Write the image file to the SD card.

Android image

5.1 You need to use Phoenix Card to make the SD card. Download the Phoenix Card from <https://drive.google.com/open?id=0BzoTh3Vdt47ffi1d0RuWXhUVzdYdjFjaHEtMINQWVFTRmlxcC1OQnczSTV6OGRZWGplNU0>

5.2 Run PhoenixCard.exe, Press "Disk Check" and select disk of SD Card.

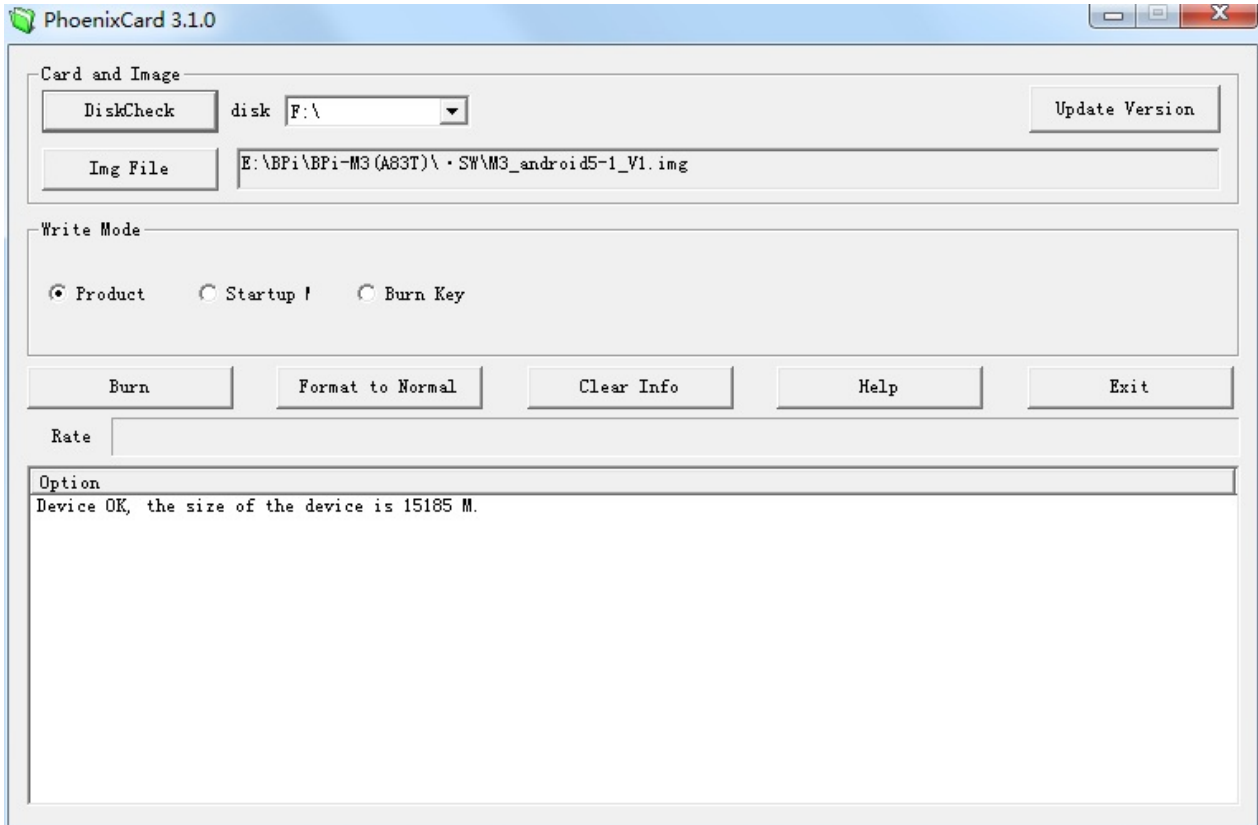

5.3 Press "Image File" and Select system.img.

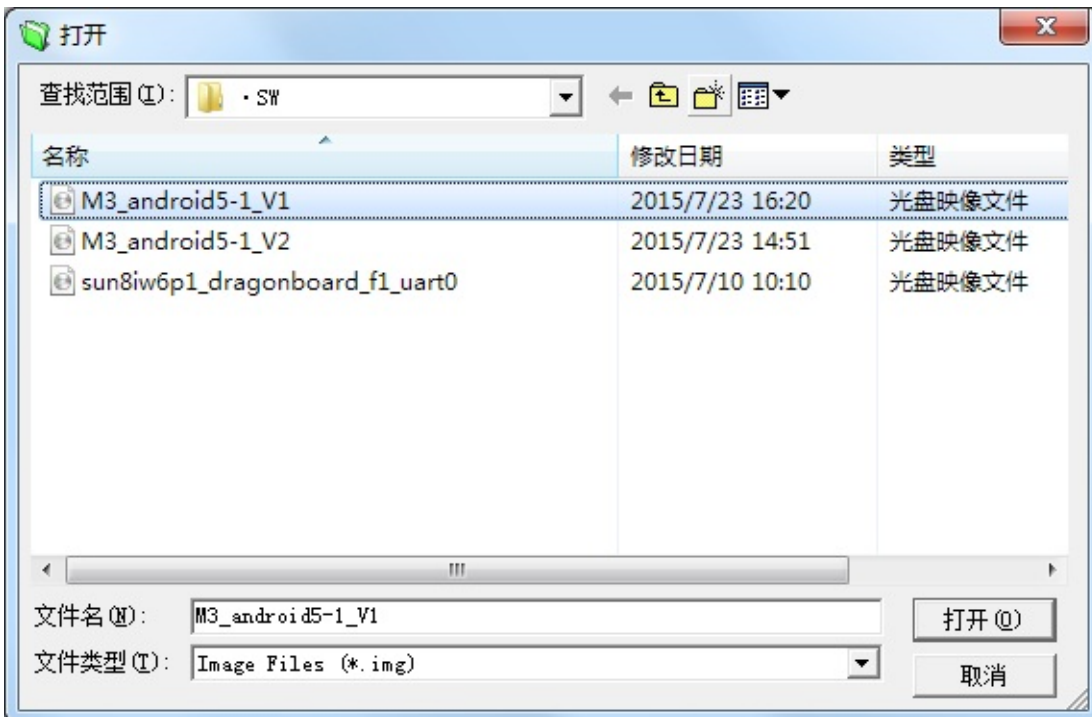

5.4 Press “Burn” to start upgrading, Upgraded complete, Press “Exit”.

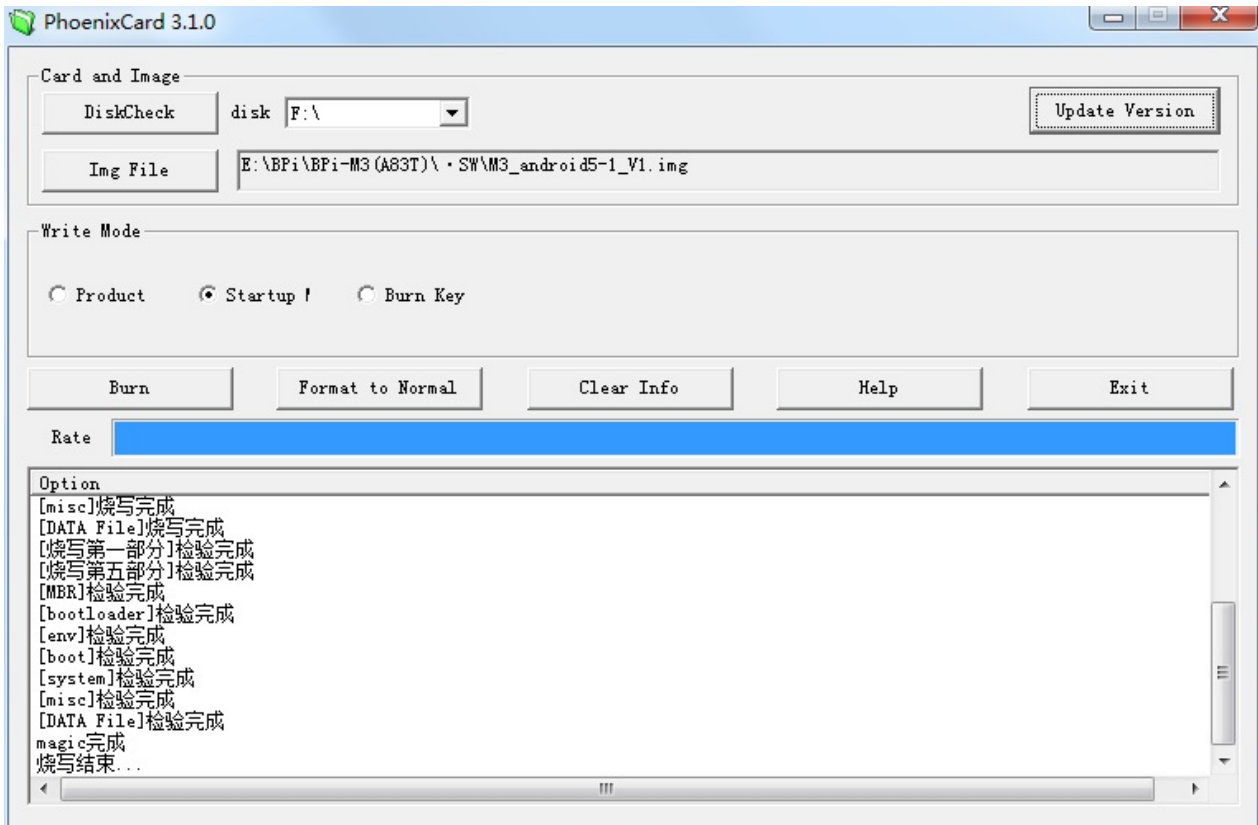
**Linux image:**

5.6 burn Linux image under Windows os:

*Download a tool that can write image to SD card, such as Win32 Diskimager from:
<http://sourceforge.net/projects/win32diskimager/files/Archive/>

*Open the unzipped image file

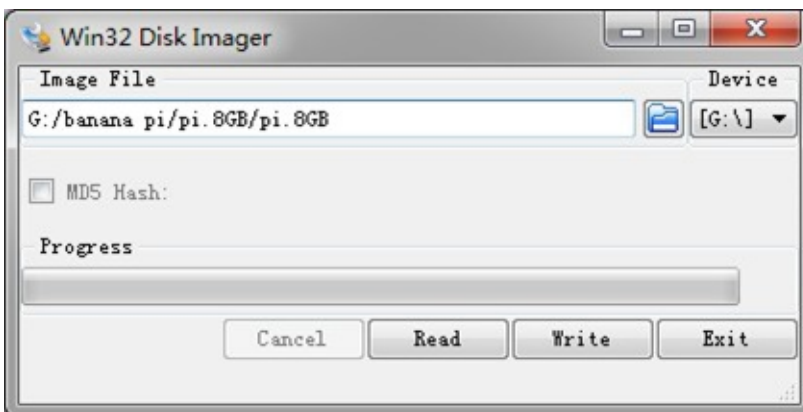

*Click Write button. Wait patiently to successfully complete writing.

5.7 burn Linux image under Linux os:

*Run `fdisk -l` command to check the SD card node.

*Run `dd if=[imagename] of=/dev/sdx` command to write image file to SD card. Wait patiently to successfully complete writing.

Step4: Set up your Banana Pi M2+

According to the set up diagram below, you can easily set up your Banana Pi.

1. Insert the written-image SD card that to the SD card spot on the left side edge of the underside of the board.
2. On the bottom "edge" in the middle of the board is the HDMI Type A (Full sized) port. Just connect any HDMI cable from the board to your TV or HDMI Monitor.
3. Plug a USB keyboard and mouse into the USB slots located on the right edge.
4. Just under the USB ports on the right edge is the Ethernet connector for anyone who wants to plug the Banana Pi into a wired network.
5. Finally, at the very left of the bottom edge is the USB power connector. Plug in a regulated power supply that is rated at 5V \pm 5% / 2000mA (or 2A). Any number bigger than 700 mA will also work. Avoid using the smaller chargers used for small GSM phones, as these are often unregulated, even if they claim "5V 1A", they may do "5V" and may do "1A", but not at the same time!

If all goes well, the Banana Pi will boot in a few minutes. The screen will display the OS GUI.

Step5: Shut down your Banana Pi

You can use the GUI to shut down the Banana Pi safely.

Also you can run the command in the terminal:

```
sudo halt OR sudo shutdown -h
```

This will shut down the PI safely, (just use the power key to turn off might damage the SD-cards file system). After that you can press the power key for 5 seconds to turn it off.

If all is well ,so you can use banana pi M2+ now.

Android software

[BPI-M2+] New image: Android 4.4 (Vserion:V3) 2017-1-11



Release Note:

1. New WIFI Chip, AP6212 - Supported
2. SDK Updated to V1.2
3. IR Status Issue - Fixed
4. Android 4.4 - Optimized

HDMI-Version

Google Drive: https://drive.google.com/open?id=0B_YnvHgh2rwjOWg4ZzBnR0VieFU

Baidu Cloud: <https://pan.baidu.com/s/1gfr7vJ9>

MD5: e50853bf5c102388b934cc4a76b25e58

Android 4.4 2016-04-11 for BPI-M2+



1. Android 4.4
2. HDMI 4K & 1080P & 720P(default) supported
3. GMAC supported
4. WIFI 802.11 b/g/n supported
5. Bluetooth 4.0 supported
6. IR supported
7. Camera ov5640 supported
8. USB Camera supported
9. adb root supported
10. adb tcp supported
11. preinstall Kodi V16 APP

Google Drive:

https://drive.google.com/file/d/0B_YnvHgh2rwjaTdEdENEYnE2UXc/view

Baidu Cloud:

<http://pan.baidu.com/s/1kUC9eGv>

MD5: 10e277ca15d74bcfe7ff710a2f29fbf4

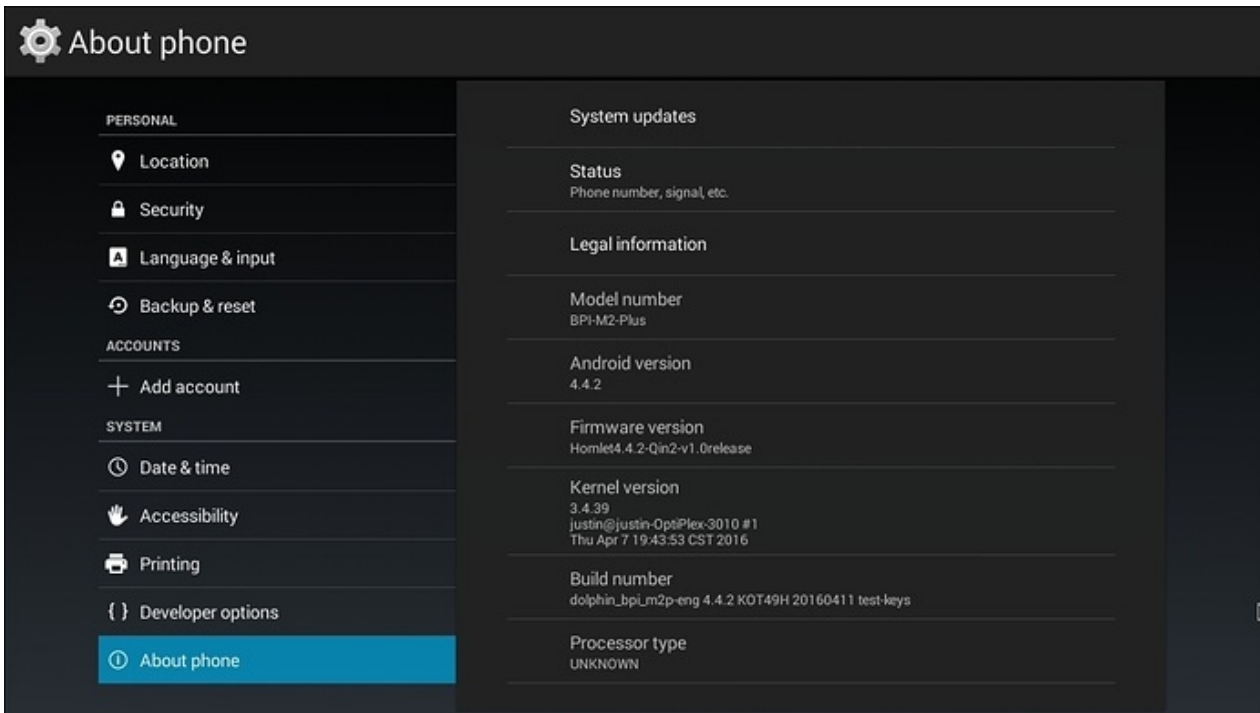

kodi support:



video play:

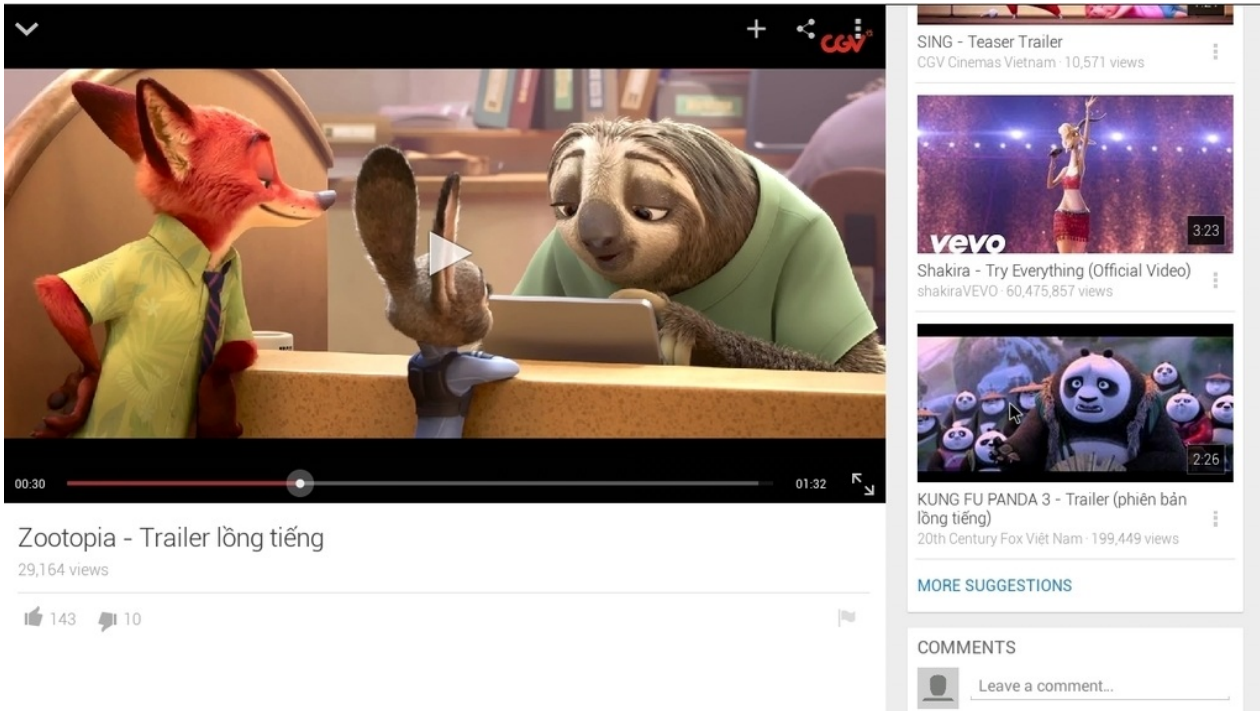

Zootopia - Trailer lồng tiếng
29,164 views
143 likes 10 dislikes

SING - Teaser Trailer
CGV Cinemas Vietnam · 10,571 views

Shakira - Try Everything (Official Video)
shakiraVEVO · 60,475,857 views

KUNG FU PANDA 3 - Trailer (phiên bản lồng tiếng)
20th Century Fox Việt Nam · 199,449 views

MORE SUGGESTIONS

COMMENTS
Leave a comment...

BPI-M2+ support android 4.4.2 image.

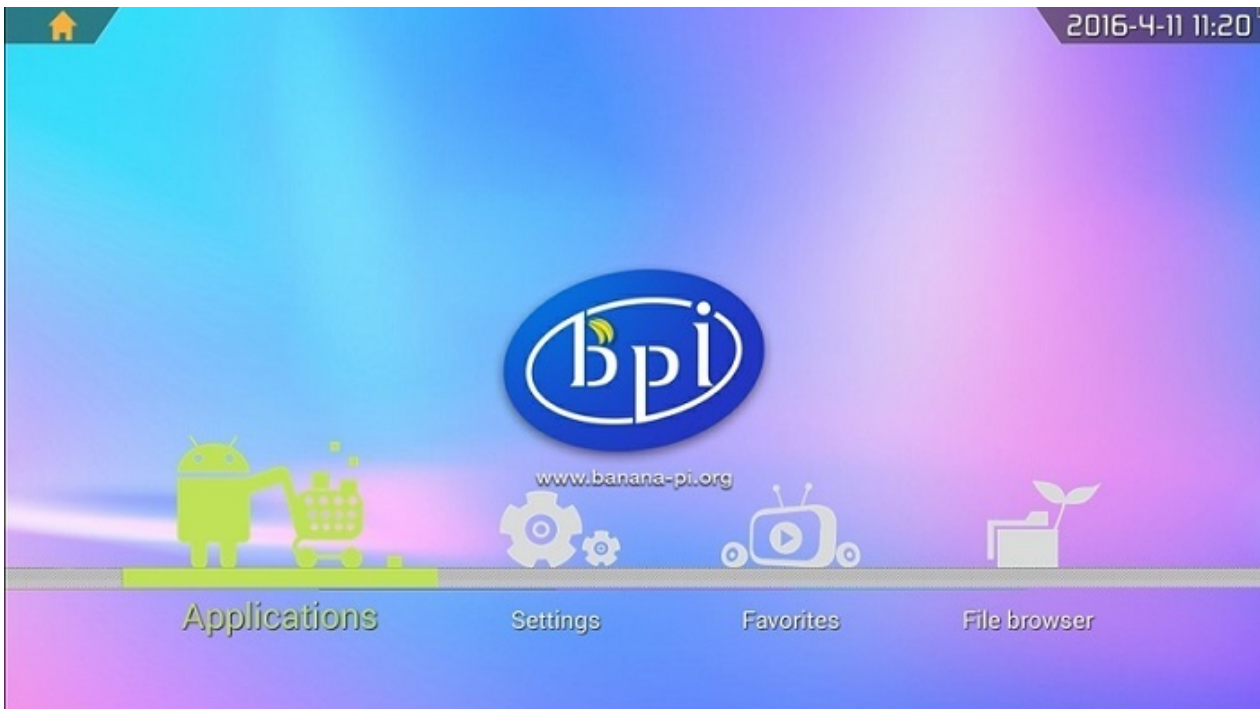

Realese note:

1. Android 4.4
2. HDMI 4K & 1080P & 720P(default) supported
3. GMAC supported
4. WIFI 802.11 b/g/n supported
5. Bluetooth 4.0 supported
6. IR supported
7. Camera ov5640 supported

8. USB Camera supported
9. adb root supported
10. adb tcp supported
11. preinstall Kodi V16 APP

Google Drive:

https://drive.google.com/file/d/0B_YnvHgh2rwjaTdEdENEYnE2UXc/view

Baidu Cloud:

<http://pan.baidu.com/s/1kUC9eGv>

MD5: 10e277ca15d74bcfe7ff710a2f29fbf4



video demo on youtube:

<https://www.youtube.com/watch?v=X61rDTGeFXy>

[BPI-M2+] New image: Android MEGA version

Android image for m2+ ,working ethernet,wifi,bt,but only botom usb,very fast on emmc

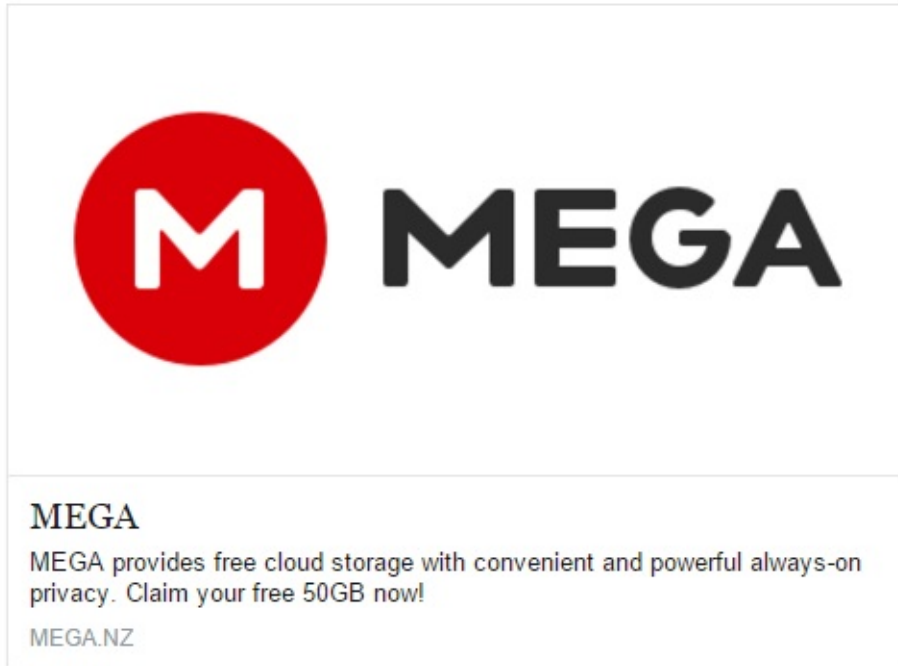

download link:

https://mega.nz/#!!E0SiQpQ!SYbiTpFrcXInvl4Wa_oJzCfUmKcdD2XftFdO-Agoth8

BPI-M2+ android 4.4 source code

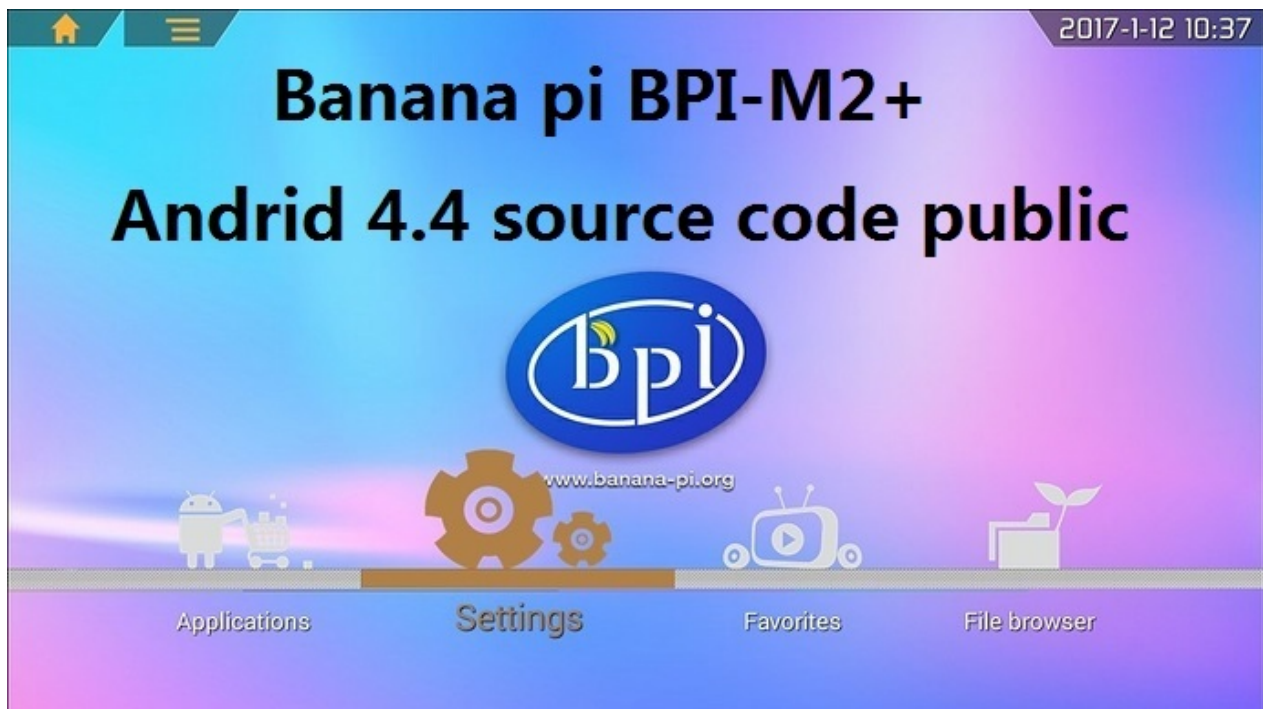

BPI-M2-Plus Android 4.4 Source code (SDK1.2)

1 Build Android BSP

```
$ cd lichee
```

```
$ ./build.sh config
```

Welcome to mkscript setup progress

All available chips:

1. sun8iw6p1
2. sun8iw7p1
3. sun8iw8p1
4. sun9iw1p1

Choice: 1

All available platforms:

1. android
2. dragonboard
3. linux

Choice: 1

2 Build Android

```
$cd ../android
```

```
$source build/envsetup.sh
```

```
$lunch //(dolphin_bpi_m2p-eng)
```

```
$extract-bsp
```

\$make -j8

\$pack

download link from google driver:

https://drive.google.com/open?id=0B_YnvHgh2rwjdWNEQzg1UDI1bUE

thank doctor lu share it.

How to burn android image to eMMC under windows

1,download BPI-M2+ android image from <http://www.banana-pi.org> download page.

2,if your PC is windows OS, please download [PhoenixSuit.zip](#) tooling to burn

if your PC is Linux OS, please download [Linux 32bit](#) or [Linux 64bit](#) tooling

example: burn android image to EMMC on windows.

1,install PhonenixSuit.

2,running PhonenixSuit. chck "one key to burn" choose your android image file.



3,press on BPI-M2+ uboot key. and plug in micro USB data line.

4 , press on Power key to boot BPI-M2+.

5 , press Yes to burn image:

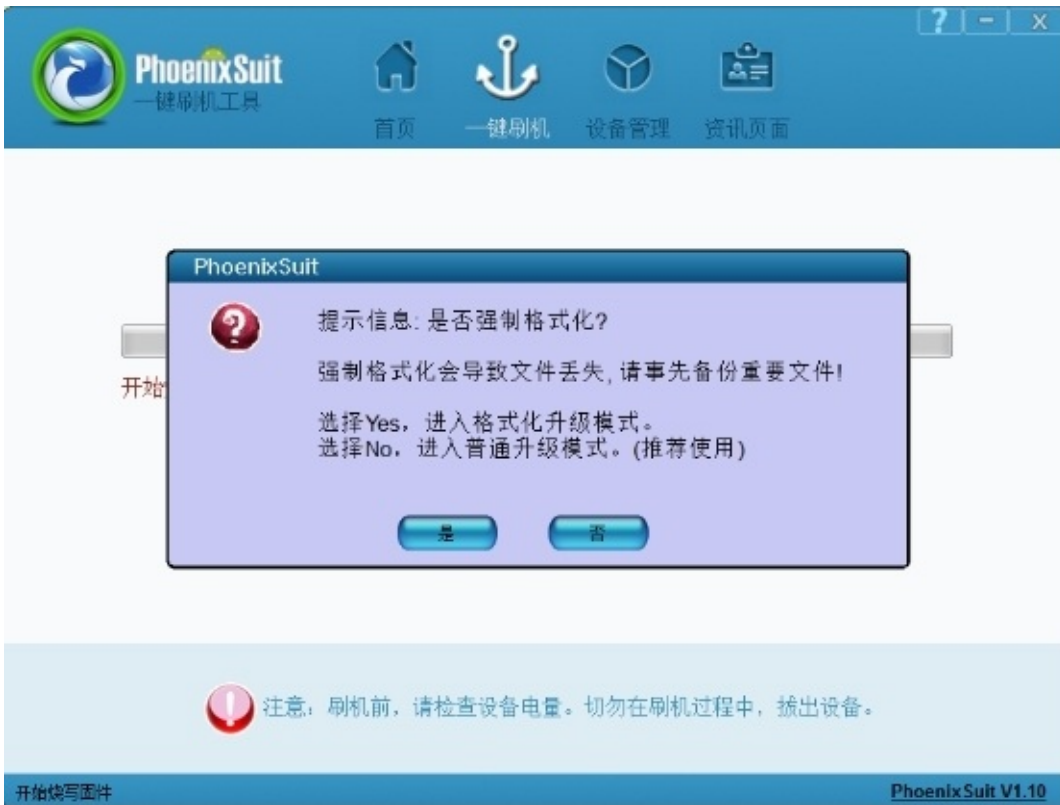

6,if all is ok , try to boot from eMMC , if not success ,just need try again.

How to burn android image to eMMC under Linux

1,download android image from <http://www.banan-pi.org> download page.

2,download [Linux 32bit](#) or [Linux 64bit](#) tooling

3,Ubuntu OS run LiveSuit_For_Linux32(or 64) Directory LiveSuit.run

```
sudo ./LiveSuit.run
```

if prompt message missing dkms module,please install it :

```
sudo apt-get install dkms
```

```
sudo ./LiveSuit.run
```

4 , install drivers:

```
sudo dpkg -i awdev-dkms_0.4_all.deb
```

5,when finished ,reboot system

6,Ubuntu system add udev rules:

```
sudo vim /etc/udev/rules.d/10-local.rules
```

7 input udev rules:

note: please replace GROUP="text" text with your user group.

```
SUBSYSTEM!="usb_device", ACTION!="add", GOTO="objdev_rules_end"  
#USBasp  
ATTRS{idVendor}=="1f3a", ATTRS{idProduct}=="efe8", GROUP="text",  
MODE="0666"  
LABEL="objdev_rules_end"
```

save & reboot or just reboot udev server, so you can run LiveSuit.sh as a general user, reboot udev command :

```
sudo service udev restart
```

8 run burn tooling(home/usernamer/Bin)

```
./LiveSuit.sh
```

9 Click "Yes" button to burn eMMC

note: when burn eMMC, it will clean all document on eMMC.

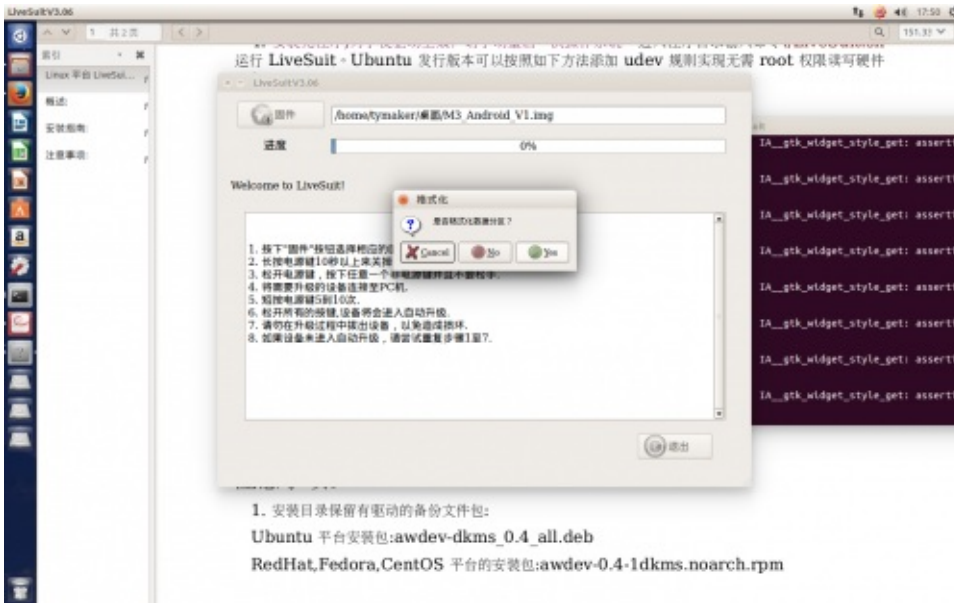

10, when all is OK ,just reboot BPI-M2+, and boot android image from eMMC flash.

Linux software

All image download link:

<http://forum.banana-pi.org/c/Banana-pi-BPI-M2/M2image>

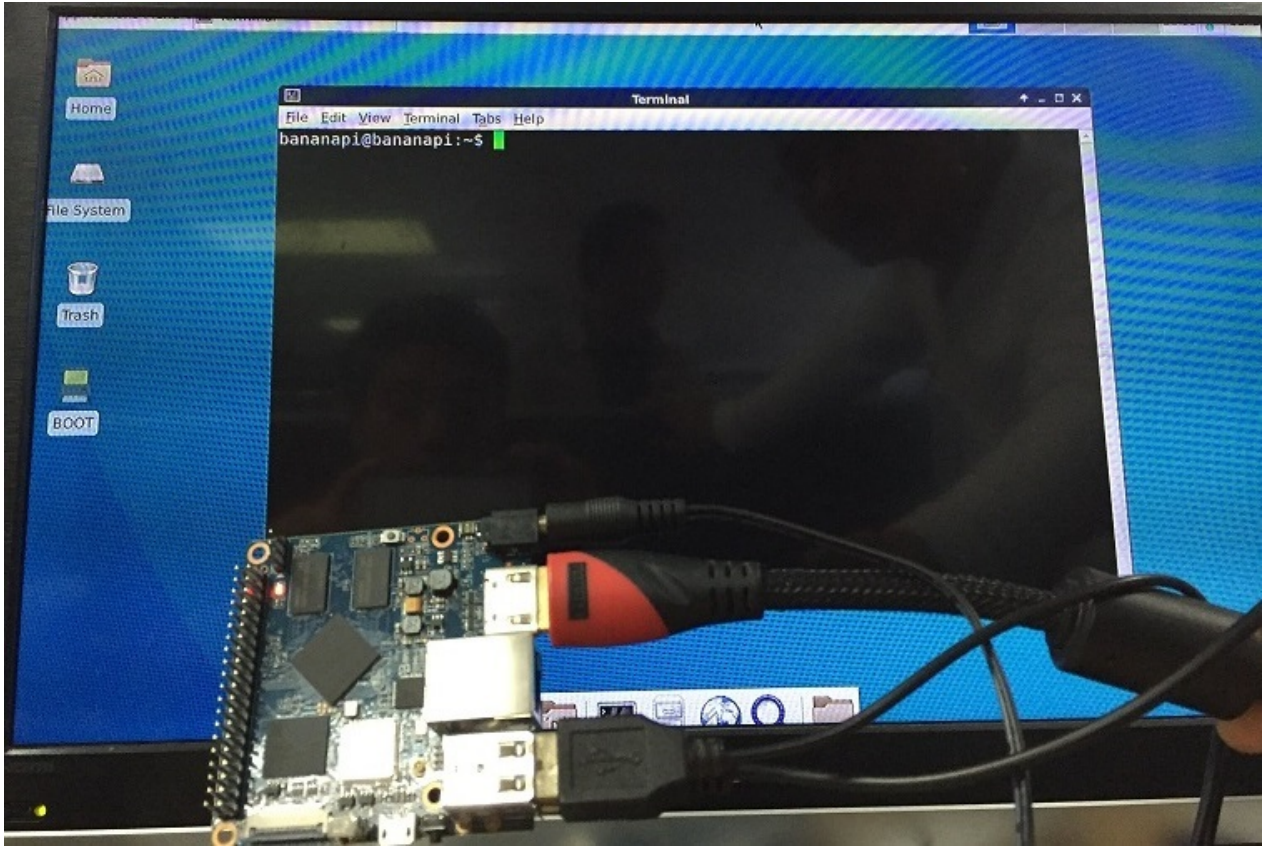

BPI-M2+,support allwinner BSP 3.4 kernel.

all 3.4 kernel image link:

<https://bananapi.gitbooks.io/bpi-m2-/content/linuxforkernel34image.html>

mainline kernel image link:

<https://bananapi.gitbooks.io/bpi-m2-/content/mainlinelinux.html>

if any use want to share image ,please share it on our forum.

How to burn Linux image to eMMC

OS: please download image from forum download link

<http://www.banana-pi.org/m2plus-download.html>

Step 1: Start up the computer with the SD card which has been burnt with the Linux images.

Step 2: Put the images which you'd like to burn to the EMMC Storage to the USB drive.

Step 3: Run "fdisk -l" command line on your BPI-M2+ and you can see the EMMC path as "/dev/mmcblk1"

```
sudo fdisk -l
```

Step 4: Switch to the path of images, and run the command.

```
sudo dd if= xxx.img of=/dev/mmcblk1 bs=10MB
```

xxx.img is your image file name

Step 5: When finish burning, remove the SD card, and restart the BPI-M2+

Step 6: Check if the system starts normally on the EMMC flash boot.

Linux for Kernel 3.4 image

allwinner BSP only support linux kernel 3.4, so we have update kernel 3.4 source code on github. and we will build image from kernel 3.4.

all driver have working fine on kernel 3.4

BPI-M2+ Ubuntu 16.04 image 2018-01-04

2018-01-04-ubuntu-16.04-mate-desktop-v1.0-bpi-m2p-sd-emmc.img.zip

Google Drive:

<https://drive.google.com/file/d/1M2BVzuRSpJr9mKT243VeB6Vwlu96gtcD/view?usp=sharing2>

Baidu cloud:

<https://pan.baidu.com/s/1bo1mCKf>

MD5: f1c5cef082488452cc15fab04c67c332

BPI-M2 Zero Ubuntu 16.04 image 2018-01-04

2018-01-05-ubuntu-16.04-mate-desktop-v1.0-bpi-m2z-sd-emmc.img.zip

Google Drive:

https://drive.google.com/file/d/1k8STlqFXuPkzKwhpc_yuCe3dOxSAyKxc/view?usp=sharing1

Baidu cloud:

<https://pan.baidu.com/s/1pLcbPbl>

MD5: 3852ef827029e562ea1f469be41c9c25

BPI-M2 Zero new image :2017-11-13-ubuntu-16.04-mate-desktop-beta-bpi-m2z-sd-emmc.img

2017-11-13-ubuntu-16.04-mate-desktop-beta-bpi-m2z-sd-emmc.img.zip



1. based on ubuntu 16.04.3 LTS Mate Desktop
2. support BPI-M2 Zero (H3 / H2+) kernel 3.4.113
3. username & password: pi/bananapi , root/bananapi
4. support HDMI 720P (default)
5. support usb ethernet
6. support WIFI
7. support BT (with bluetoothctl can setup)
8. support UART
9. support I2C (test with bpi_test_lcd1602)
10. support SPI (test with bpi_test_hello & bpi_test_52pi)
11. support DVFS (pmu type: gpio PL01 switch 1.1V / 1.3V)
12. support power key (getevent can test)
13. support OTG (can connect to usb hub)
14. support CAMERA ov5640 (guvcview / cap / ffmpeg-3.1.4 support video H.264 hw encode)
15. support boot.scr to fatload zImage
16. support bpi-bootsele
17. support bpi-copy
18. support video play with vdpau (mpv)
19. support mali gpu (glmark2-es2 can test)

20. support xrdp
21. support chromium 62.0.3202.75
22. support wiringpi 2.44 (<https://github.com/BPI-SINOVOIP/WiringPi>, thanks to <http://wiringpi.com/> & <https://github.com/WiringPi/WiringPi>)
23. support rpi.gpio 0.6.3 for python (<https://github.com/BPI-SINOVOIP/RPi.GPIO>, thanks to <https://sourceforge.net/projects/raspberry-gpio-python/>)
24. Thanks for linux-sunxi community (<http://linux-sunxi.org/>)
25. Thanks for armbian (<http://www.armbian.com/>)
26. Special thanks for Alex support with camera functions (<https://github.com/avafinger/>)
27. ref. <https://github.com/BPI-SINOVOIP/BPI-M2Z-bsp>
28. ref. <https://bananapi.gitbooks.io/bpi-m2-/content/en/>

Google Drive:

<https://drive.google.com/file/d/1Q4NxmO33RYtmECZ8BobW6DXzGWkvCs9F/view?usp=sharing>

baidu cloud:

<http://pan.baidu.com/s/1gfvRUk7>

MD5: 8497e0ec059c3dc323abdb4fcf19fa1c

FILESIZE: 1724354650 (~1644MB)

UNPACK: 7296MB (eMMC size)

BPI-M2 Zero test image : 2017-11-10-armbian_5.34-m2-zero-Debian_jessie_default_3.4.113_desktop_beta_build_by_bpi

2017-11-10-Armbian_5.34_Bananapim2zero_Debian_jessie_default_3.4.113_beta_build_by_bpi.img.zip

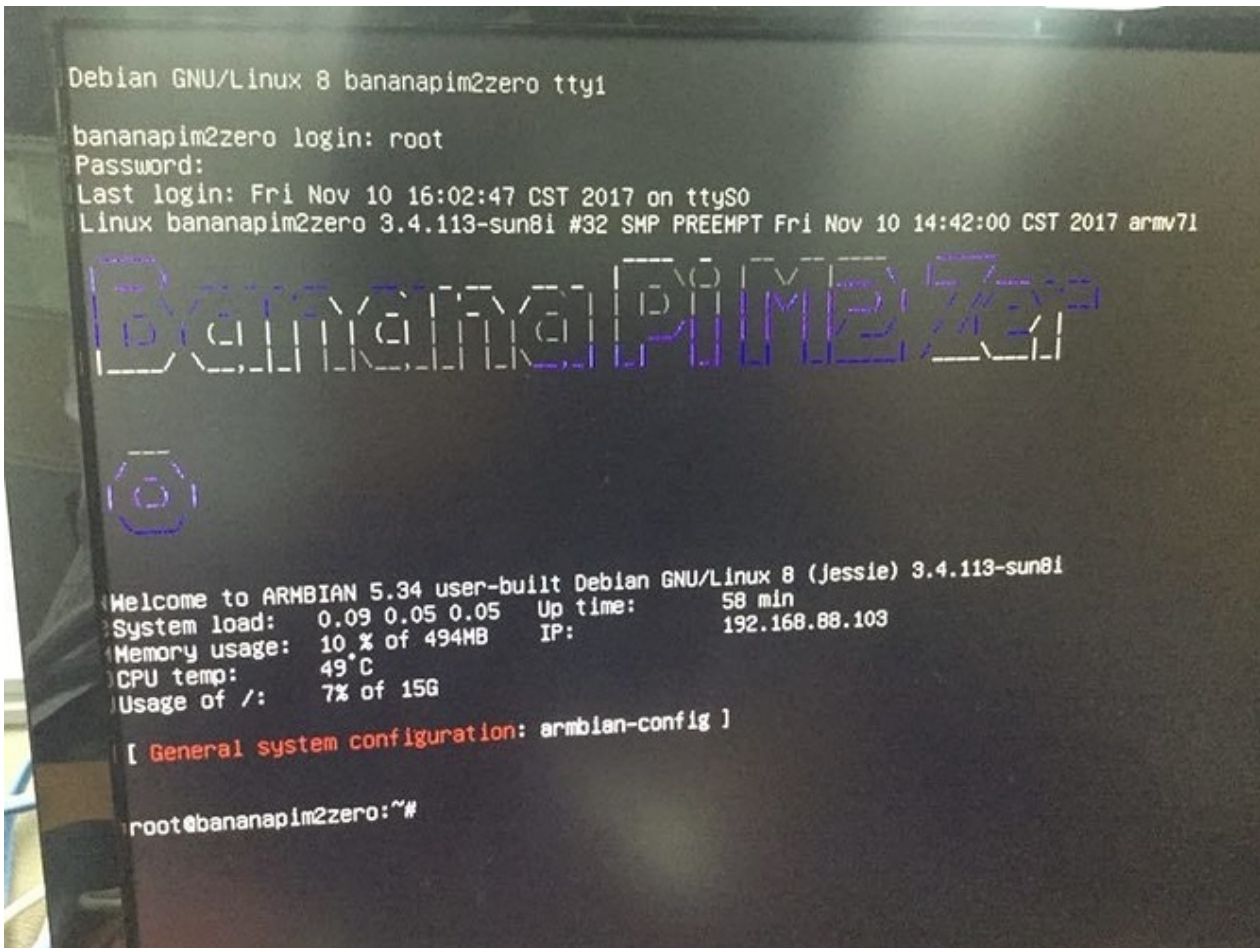

1. based on Debian 8 jessie lite build with armbian's work by bpi
2. support BPI-M2 Zero (H3 / H2+) kernel 3.4.113
3. username & password: root/1234 (armbian default)
4. support HDMI (default)
5. support WIFI
6. support OTG
7. support DVFS (pmu type: gpio PL01 switch 1.1V / 1.3V)
8. Thanks for linux-sunxi community (<http://linux-sunxi.org/>)
9. Thanks to armbian's work (<https://www.armbian.com/>)
10. ref. patch files (<https://github.com/BPI-SINOVOIP/BPI-files/tree/master/others/armbian>)
11. ref. <https://github.com/BPI-SINOVOIP/BPI-M2Z-bsp>
12. ref. <https://bananapi.gitbooks.io/bpi-m2-/content/en/>

Google Drive:

https://drive.google.com/file/d/1MAhVwjKwzPb1PKqldbIF_hW6gScQVBfk/view?usp=sharing

baidu cloud:

<http://pan.baidu.com/s/1hrTzw1Y>

MD5: 3c57d44843db8201e125b25ec9214bcb

FILESIZE: 284631127 (~271MB)

UNPACK: ~1140MB (will auto resize after setup)

BPI-M2 Zero test image : 2017-11-10-armbian_5.34-m2-zero-Ubuntu-xenial_default_3.4.113_desktop_beta_build_by_bpi

2017-11-10-Armbian_5.34_Bananapim2zero_Ubuntu_xenial_default_3.4.113_desktop_beta_build_by_bpi.img.zip

1. based on ubuntu 16.04.3 LTS Xfce Desktop build with armbian's work by bpi
2. support BPI-M2 Zero (H3 / H2+) kernel 3.4.113
3. username & password: root/1234 (armbian default)
4. support HDMI (default)
5. support WIFI
6. support BT (with bluetoothctl can setup)
7. support OTG
8. support DVFS (pmu type: gpio PL01 switch 1.1V / 1.3V)
9. support video play 1080p with vdpau (mpv)
10. Thanks for linux-sunxi community (<http://linux-sunxi.org/>)
11. Thanks to armbian's work (<https://www.armbian.com/>)
12. ref. patch files (<https://github.com/BPI-SINOVOIP/BPI-files/tree/master/others/armbian>)
13. ref. <https://github.com/BPI-SINOVOIP/BPI-M2Z-bsp>
14. ref. <https://bananapi.gitbooks.io/bpi-m2-/content/en/>

Google Drive:

<https://drive.google.com/file/d/1YR77WpCZhKKGsOjJqw3BK9qXQbgK5BUX/view?usp=sharing>

baidu cloud:

<http://pan.baidu.com/s/1jlek80e>

MD5: 683d53763fef7e29d2b651ed6c81bc56

FILESIZE: 805440746 (~768MB)

UNPACK: ~2844MB (will auto resize after setup)

BPI-M2 Zero/M2+ test image : 2017-11-08-armbian_5.34-m2-zero-Ubuntu-xenial_default_3.4.113_desktop

2017-11-08-armbian_5.34_Bananapim2zero_Ubuntu_xenial_default_3.4.113_desktop_preview_build_by_bpi.img.zip

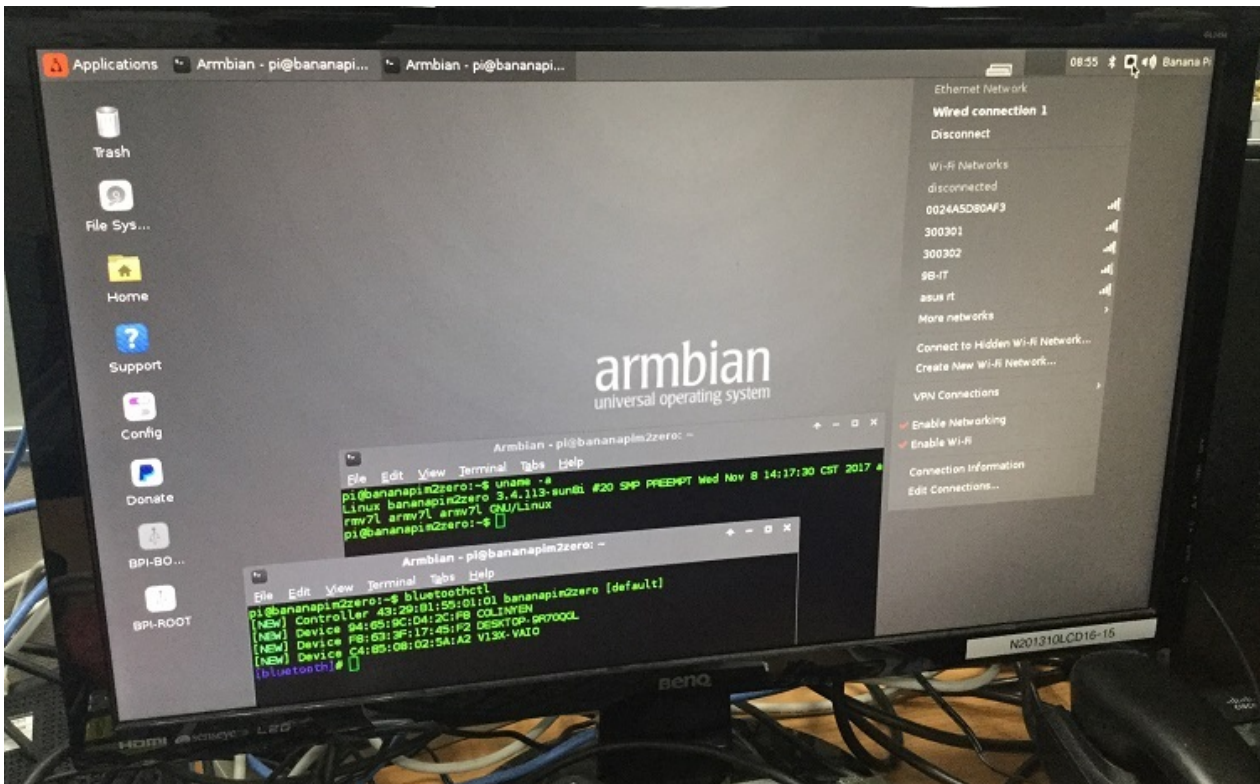

1. based on ubuntu 16.04.3 LTS Xfce Desktop build with armbian's work by bpi
2. support BPI-M2 Zero (H3 / H2+) kernel 3.4.113
3. username & password: root/1234 (armbian default)
4. support HDMI (default)
5. support WIFI
6. support BT (with bluetoothctl can setup)
7. support OTG
8. support video play 1080p with vdpau (mpv)
9. Thanks for linux-sunxi community (<http://linux-sunxi.org/>)
10. Thanks to armbian's work (<https://www.armbian.com/>)
11. ref. patch files (<https://github.com/BPI-SINOVOIP/BPI-files/commit/c4bdb2b5d928042c5f592fafd4796f4b9f24e229>)
12. ref. <https://github.com/BPI-SINOVOIP/BPI-M2Z-bsp>
13. ref. <https://bananapi.gitbooks.io/bpi-m2-/content/en/>

issue:

1. show the bluetooth network warning message on the boot time.

Google Drive:

<https://drive.google.com/file/d/1dzW525MIMEZZdPJf2KXLYTdX83MluPK1/view?usp=sharing>

baidu cloud:

<http://pan.baidu.com/s/1eRDorQE>

MD5: dd1e66d3025f1a6942cbc728b47bd41e

FILESIZE: 843350325 (~804MB)

UNPACK: ~2972MB (will auto resize after setup)

just for test image ,thank mikey share this .

BPI-M2+ new image:ubuntu-16.04-mate-desktop-beta-bpi-m2p-sd-emmc-2017-07-14

2017-07-14-ubuntu-16.04-mate-desktop-beta-bpi-m2p-sd-emmc.img.zip

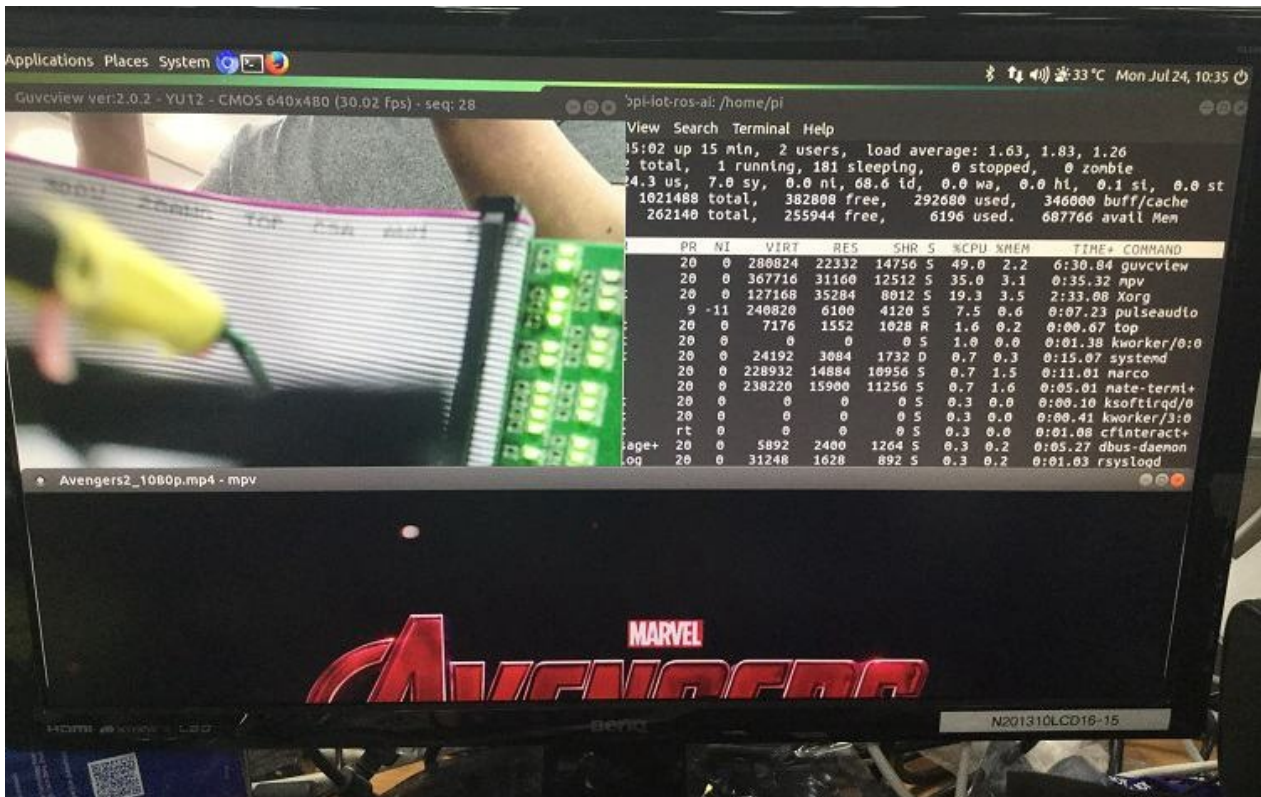

1. based on ubuntu 16.04.2 LTS Mate Desktop
2. support BPI-M2+ kernel 3.4
3. username & password: pi/bananapi , root/bananapi
4. support HDMI 1080P & 480P & 720P (default)
5. support GMAC
6. support WIFI
7. support BT (with bluetoothctl can setup)
8. support UART
9. support I2C
10. support eMMC (support boot from eMMC)
11. support IR (getevent can test)
- 11 support power key (getevent can test)
 1. support OTG & abdb (default off)
 2. support CAMERA ov5640 (guvcview / cap / ffmpeg-3.2.1 support video H.264 hw encode)
 3. support uEnv.txt to fatload ulmage
 4. support bpi-bootsel to set HDMI (720P & 1080P & 480P)
 5. support bpi-copy to write SD/eMMC with img.zip file

6. support video play 1080p with vdpau (mpv)
7. support wiringpi 2.44 (<https://github.com/BPI-SINOVOIP/WiringPi> , thanks to <http://wiringpi.com/> & <https://github.com/WiringPi/WiringPi>
8. support rpi.gpio 0.6.3 for python (<https://github.com/BPI-SINOVOIP/RPi.GPIO> , thanks to <https://sourceforge.net/projects/raspberry-gpio-python/>
9. Thanks for linux-sunxi community (<http://linux-sunxi.org/>)
10. Special thanks for Alex support with camera functions (<https://github.com/avafinger>)

Google Drive:

https://drive.google.com/file/d/0B_YnvHgh2rwjbnNUeEE0bzhpWm8/view?usp=sharing

baidu cloud:

<http://pan.baidu.com/s/1dEX2TDR>

MD5: 036bb7a88c7dd06c5d41e50f1538a6fa

FILESIZE: 1757053148 (~1675MB)

UNPACK: 7456MB (eMMC size)

BPI-M2 Zero new image:ubuntu-16.04-mate-desktop-demo-bpi-m2z-sd.img-2017-07-21

2017-07-21-ubuntu-16.04-mate-desktop-demo-bpi-m2z-sd.img.zip

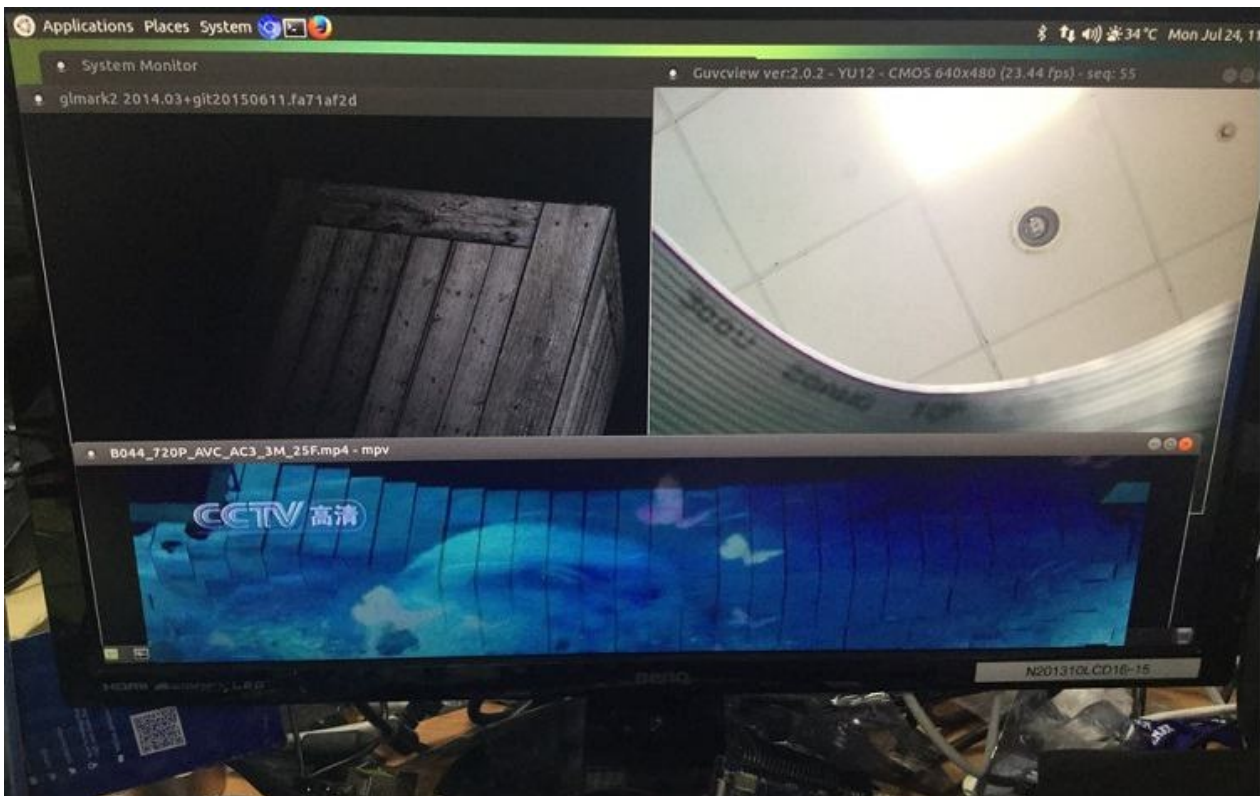

1. based on ubuntu 16.04.2 LTS Mate Desktop
2. support BPI-M2 Zero kernel 3.4.113 with u-boot-2017.07
3. username & password: pi/bananapi , root/bananapi
4. support HDMI 720P (default)
5. support usb ethernet

6. support WIFI
7. support BT (with bluetoothctl can setup)
8. support UART
9. support I2C
10. support power key (getevent can test)
11. support OTG (can connect to usb hub)
12. support CAMERA ov5640 (gucvview / cap / ffmpeg-3.2.1 support video H.264 hw encode)
13. support boot.scr to fatload zImage
14. support bpi-bootsel
15. support bpi-copy
16. support video play with vdpau (mpv)
17. support mali gpu (glmark2-es2 can test)
18. support wiringpi 2.44 (<https://github.com/BPI-SINOVOIP/WiringPi> , thanks to <http://wiringpi.com/> & <https://github.com/WiringPi/WiringPi>)
19. support rpi.gpio 0.6.3 for python (<https://github.com/BPI-SINOVOIP/RPi.GPIO> , thanks to <https://sourceforge.net/projects/raspberry-gpio-python/>)
20. Thanks for linux-sunxi community (<http://linux-sunxi.org/>)
21. Thanks for armbian (<http://www.armbian.com>)
22. Special thanks for Alex support with camera functions (<https://github.com/avafinger>)

Google Drive:

https://drive.google.com/file/d/0B_YnvHgh2rwjWINDemZsODhneUE/view?usp=sharing

baidu cloud:

<http://pan.baidu.com/s/1eR6wBU6>

MD5: cc7116a8fa3f76dfbf899ad3bc192357

FILESIZE: 1757053148 (~1675MB)

UNPACK: 7456MB (eMMC size)

BPI-M2+ new image : berryboot-v2.0-debian-8-nodejs-preview-bpi-m2p-sd-emmc.img 2017-03-29

2017-03-29-berryboot-v2.0-debian-8-nodejs-preview-bpi-m2p-sd-emmc.img.zip



this image include 3 version:

- berryboot V2.0 (20170308) newest version
- base debian 8 lite
- debian 8 lite + nodejs v6.10.1
- debian 8 mate desktop + nodejs v6.10.1

download link:

https://drive.google.com/file/d/0B_YnvHgh2rwjR3ZRT0I1Ykw0Vms/view

BPI-M2+ new image:berryboot-preview-bpi-m2p.img 2016-08-24

2016-08-24-berryboot-preview-bpi-m2p.img.zip

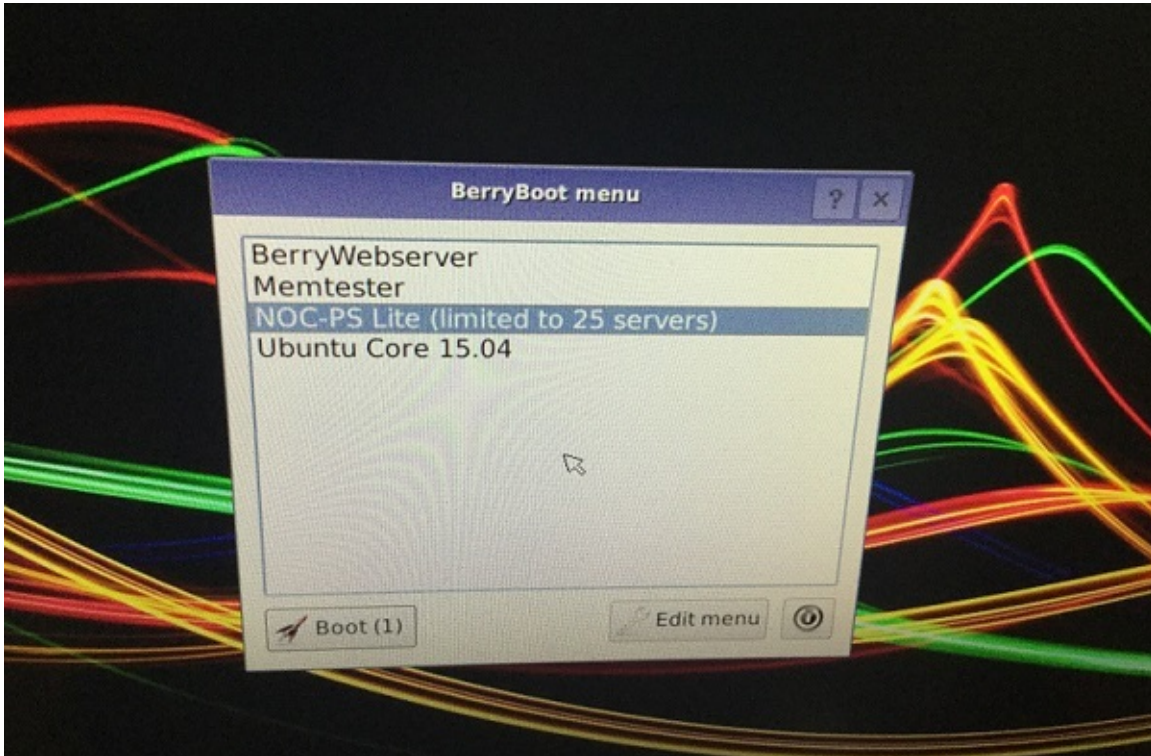

1. based on berryboot-20160807-pi2-pi3.zip from <http://www.berryterminal.com/doku.php/berryboot>
2. BPI-M2P kernel 3.4.39
3. username & password: pi/bananapi (NOC-PS Lite), root (Ubuntu Core 15.04)
4. support HDMI 1080P & 720P(default)
5. support eMMC
6. support GMAC
7. support WIFI
8. support bpi-bootsel cmd can switch to (bpi-m3 & bpi-m2p) under Ubuntu Core 15.04
9. support uEnv.txt to fatload script.bin & ulmage
10. support uEnv.txt to set video 1080P & 720P & 480P ...
11. fix rootmydevice issue
12. preload NOC-PS Lite(limited_to_25_servers).img (<https://www.noc-ps.com/>)
13. preload Ubuntu_Core_15.04.img192
14. preload BerryWebserver.img240 for Minimal webserver distribution (Lighty + PHP + SQLite)
15. thanks to <http://www.berryterminal.com/>

Google Drive:

https://drive.google.com/file/d/0B_YnvHgh2rwjWjIQZC15RkJMd1U/view?usp=sharing

MD5: 295f94d7d70cd298faa73fcafb8694d3

discuss on forum:

<http://forum.banana-pi.org/t/bpi-m2-new-image-berryboot-preview-bpi-m2p-img-2016-08-24/2168>

BPI-M2+ new image:ubuntu-mate-16.04-desktop-armhf- raspberrypi-bpi-m2p-sd-emmc.img 2016-07-21

2016-07-21-ubuntu-mate-16.04-desktop-armhf-raspberry-pi-bpi-m2p-sd-emmc.img.zip

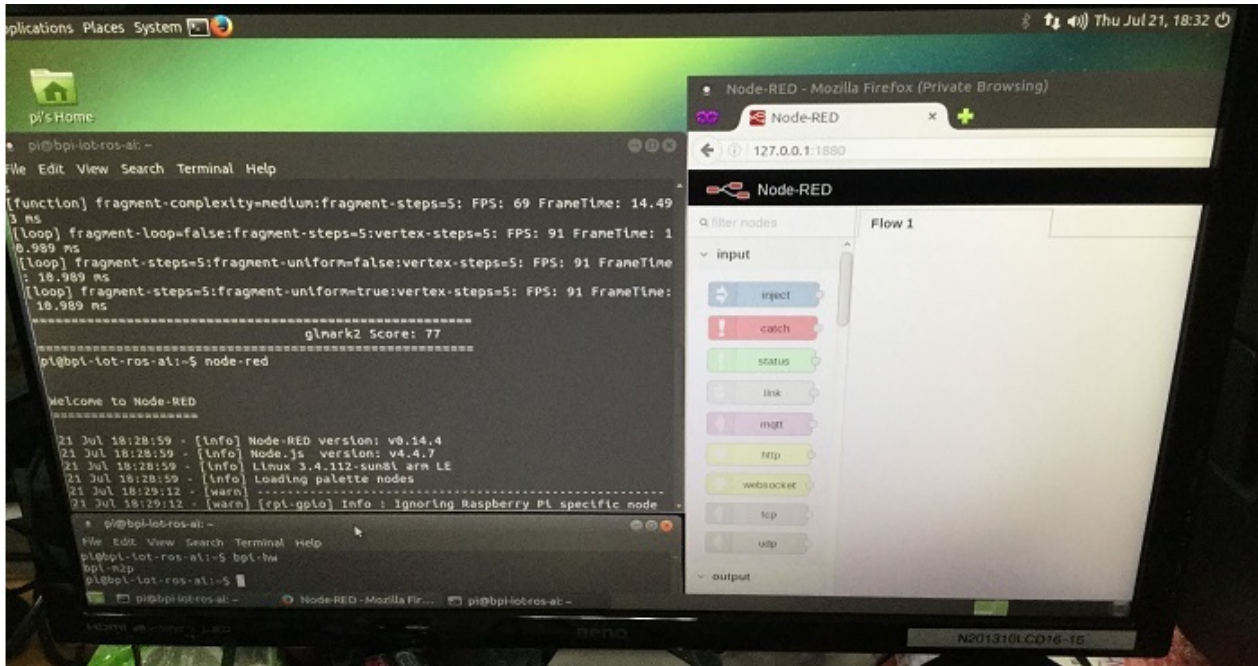

1. based on ubuntu 16.04 mate from <https://ubuntu-mate.org/download/>
2. BPI-M2P kernel 3.4.39 / kernel 3.4.112 (default)
3. username & password: pi/bananapi , root/bananapi
4. support HDMI 1080P & 720P(default)
5. support eMMC
6. support GMAC
7. support WIFI
8. support bpi-bootsetl cmd can switch to (bpi-m64 & bpi-m3 & bpi-m2 & bpi-m2p & bpi-m1-m1p-r1)
9. support uEnv.txt to fatload script.bin & ulmage
10. support uEnv.txt to set video 1080P & 720P & 480P ...
11. fix rootmydevice issue
12. support BT (default on, command only, can hcitool scan)
13. kernel 3.4.112 (based on armbian's build), thanks for armbian (<http://www.armbian.com>)
14. kernel 3.4.112 github from <https://github.com/igorpecovnik/lib> by armbian's work
15. support video play 1080p with vdpau (mpv)
16. support GPU Mali (glmark2-es2)
17. support nodejs
18. support node-red
19. thanks to ubuntu-mate.org

Google Drive:

https://drive.google.com/file/d/0B_YnvHgh2rwdtJWbVp5V1NPUTg/view?usp=sharing

MD5: 4d5c85920a355c213cb306d0d71f548f

note : this image is from ubuntu 16.04 for raspberry pi version ,we let it support banana pi. support mali GPU and powerVR gpu function.

discuss on forum:

<http://forum.banana-pi.org/t/bpi-m2-new-image-ubuntu-mate-16-04-desktop-armhf-raspberry-pi-bpi-m2p-sd-emmc-img-2016-07-21/2050>

BPI-M2+ new image:edu-ubuntu-mate-1604-preview-bpi-

m2p.img 2016-07-19

2016-07-19-edu-ubuntu-mate-1604-preview-bpi-m2p.img.zip

```

pi@bananapi: ~
File Edit View Search Terminal Help
Error: SceneTerrain requires Vertex Texture Fetch support, but GL_MAX_VERTEX_TEXTURE_IMAGE_UNITS is 0
[terrain] <default>: Unsupported
[shadow] <default>: FPS: 42 FrameTime: 23.810 ms
[refract] <default>: FPS: 27 FrameTime: 37.037 ms
[conditionals] fragment-steps=0:vertex-steps=0: FPS: 96 FrameTime: 10.417 ms
[conditionals] fragment-steps=5:vertex-steps=0: FPS: 85 FrameTime: 11.765 ms
[conditionals] fragment-steps=0:vertex-steps=5: FPS: 95 FrameTime: 10.526 ms
[function] fragment-complexity=low:fragment-steps=5: FPS: 94 FrameTime: 10.638 ms
[function] fragment-complexity=medium:fragment-steps=5: FPS: 69 FrameTime: 14.493 ms
[loop] fragment-loop=false:fragment-steps=5:vertex-steps=5: FPS: 94 FrameTime: 10.638 ms
[loop] fragment-steps=5:fragment-uniform=false:vertex-steps=5: FPS: 93 FrameTime: 10.753 ms
[loop] fragment-steps=5:fragment-uniform=true:vertex-steps=5: FPS: 93 FrameTime: 10.753 ms
=====
glmark2 Score: 84
=====
pi@bananapi:~$ bpi-hw
bpi-m2p
pi@bananapi:~$

```

1. based on ubuntu 16.04 mate from bpi-m3-mate (<http://opensource.ntpc.edu.tw/>)
2. BPI-M2P kernel 3.4.39 / kernel 3.4.112 (default)
3. username & password: pi/bananapi , root/bananapi
4. support HDMI 1080P & 720P(default)
5. support eMMC
6. support GMAC
7. support WIFI
8. support bpi-bootset cmd can switch to (bpi-m64 & bpi-m3 & bpi-m2 & bpi-m2p & bpi-m1-m1p-r1)
9. support uEnv.txt to fatload script.bin & ulmage
10. support uEnv.txt to set video 1080P & 720P & 480P ...
11. fix rootmydevice issue
12. support BT (default on, command only, can hcitool scan)
13. kernel 3.4.112 (based on armbian's build), thanks for armbian (<http://www.armbian.com>)
14. kernel 3.4.112 github from <https://github.com/igorpecovnik/lib> by armbian's work
15. support video play 1080p with vdpau (mpv, vlc, smplayer)
16. support GPU Mali (glmark2-es2)
17. support nodejs
18. support node-red
19. included many apps for edu
20. support scratch 2 online with scratchx
21. special thanks to the team of <http://opensource.ntpc.edu.tw/>

info: need >= 16GB SD and not use for eMMC(8GB)

Google Drive:

https://drive.google.com/file/d/0B_YnvHgh2rwjdXIMTWWh5Ni1LRU0/view?usp=sharing

MD5: 988f4f457910c1d35b724e337b89b226

discuss on forum:

<http://forum.banana-pi.org/t/bpi-m2-new-image-edu-ubuntu-mate-1604-preview-bpi-m2p-img-2016-07-19/2041>

BPI-M2+ new image:Kanux-Beta-3.3.0-preview-bpi-m2p.img 2016-07-15

2016-07-15-Kanux-Beta-3.3.0-preview-bpi-m2p.img.zip

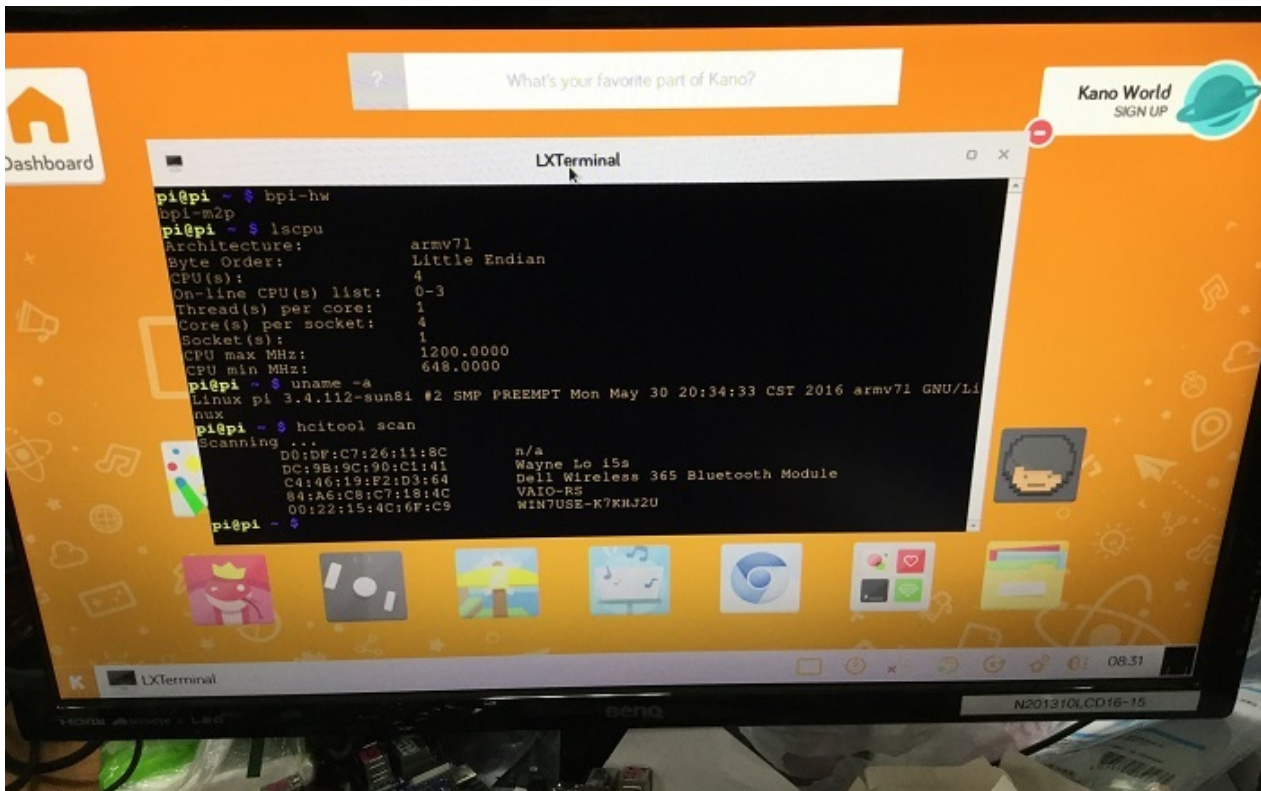

1. based on KANO OS Beta 3.3.0 (support rpi3 rpi2 rpi1)
2. BPI-M2P kernel 3.4.39 / kernel 3.4.112 (default)
3. username & password: pi/bananapi , root/bananapi
4. support HDMI 1080P & 720P(default)
5. support eMMC
6. support GMAC
7. support WIFI
8. support bpi-bootsel cmd can switch to (bpi-m64 & bpi-m3 & bpi-m2 & bpi-m2p & bpi-m1-m1p-r1)
9. support uEnv.txt to fatload script.bin & ulmage
10. support uEnv.txt to set video 1080P & 720P & 480P ...
11. fix rootmydevice issue
12. support BT (hcitool scan)
13. kernel 3.4.112 (based on armbian's build), thanks for armbian (<http://www.armbian.com>)
14. kernel 3.4.112 github from <https://github.com/igorpecovnik/lib> by armbian's work
15. thanks for Kano Developers's work(<http://developers.kano.me/downloads/>)
16. thanks for raspberry.org's work

Google Drive:

https://drive.google.com/file/d/0B_YnvHgh2rwjXy1FQ0F3ajVvVVE/view?usp=sharing

MD5: e31405a5783aa62b67c9c1d550fe4fab

discuss on forum:

<http://forum.banana-pi.org/t/bpi-m2-new-image-kanux-beta-3-3-0-preview-bpi-m2p-img-2016-07-15/2023>

BPI-M2+ new image:Raspbian-jessie-bpi-m2p.img 2016-07-13

2016-07-13-raspbian-jessie-bpi-m2p.img.zip

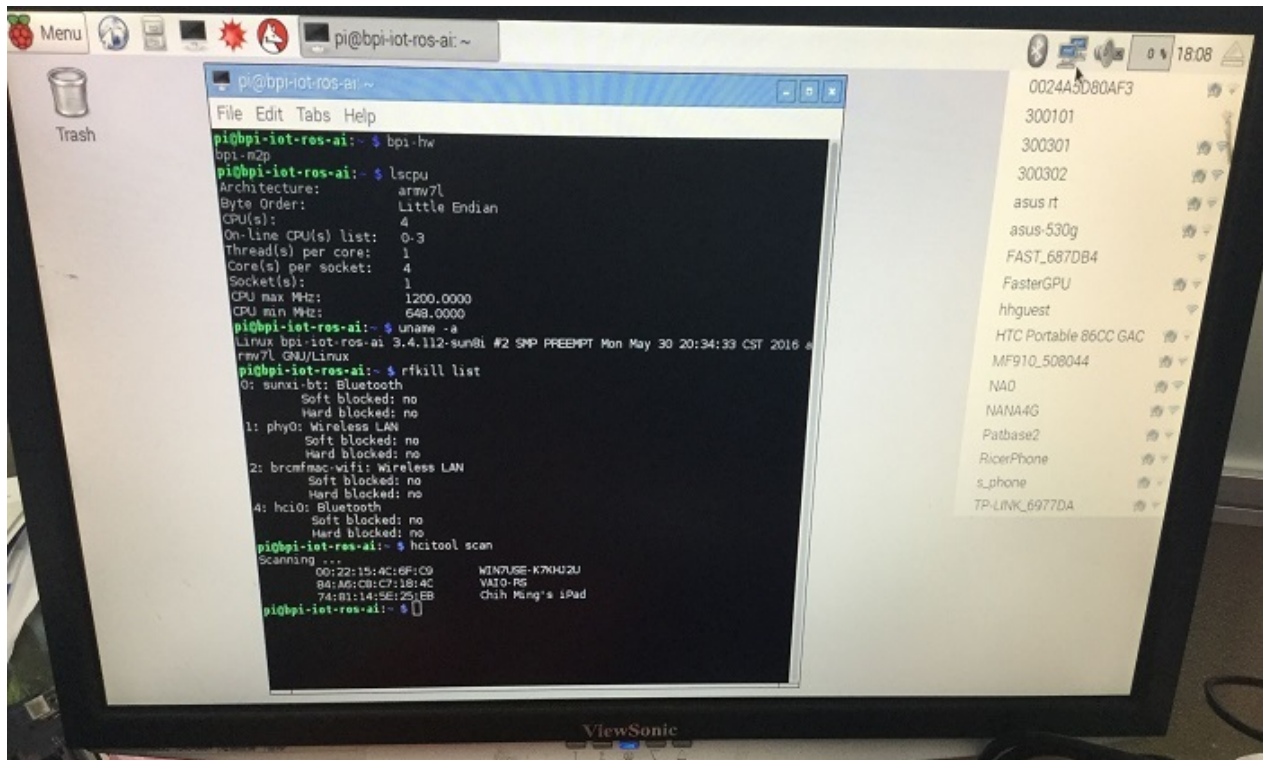

1. based on RASPBIAN JESSIE 2016-05-27(support rpi3 rpi2 rpi1)
2. BPI-M2P kernel 3.4.39 / kernel 3.4.112 (default)
3. username & password: pi/bananapi , root/bananapi
4. support HDMI 1080P & 720P(default)
5. support eMMC
6. support GMAC
7. support WIFI
8. support bpi-bootsel cmd can switch to (bpi-m64 & bpi-m3 & bpi-m2 & bpi-m2p & bpi-m1-m1p-r1)
9. support uEnv.txt to fatload script.bin & ulmage
10. support uEnv.txt to set video 1080P & 720P & 480P ...
11. fix rootmydevice issue
12. support BT (hcidtool scan)
13. kernel 3.4.112 (based on armbian's build), thanks for armbian
14. kernel 3.4.112 github from <https://github.com/igorpecovnik/lib> by armbian's work
15. thanks for raspberry.org's work(<https://www.raspberrypi.org/downloads/raspbian>)
16. support node-red

Google Drive:

https://drive.google.com/file/d/0B_YnvHgh2rwbjGRQamVmYlppc28/view?usp=sharing

MD5: d3dbc4e70139538a666ec2176bccb7a8

discuss on forum:

<http://forum.banana-pi.org/t/bpi-m2-new-image-raspbian-jessie-bpi-m2p-img-2016-07-13/2008>

BPI-M2+ new image: Raspbian-lite-bpi-m2p.img 2016-07-12

2016-07-12-raspbian-lite-bpi-m2p.img.zip

```

Starting Update UTMPT about System Runlevel Changes...
[ OK ] Started Update UTMPT about System Runlevel Changes.
Raspbian GNU/Linux 8 bpi-iot-ros-ai tty1
bpi-iot-ros-ai login: pi
Password:
Last login: Mon Jul 11 20:20:24 CST 2016 on tty1
Linux bpi-iot-ros-ai 3.4.112-sun8i #2 SMP PREEMPT Mon May 30 20:34:33 CST 2016 armv7l

The programs included with the Debian GNU/Linux system are free software;
the exact distribution terms for each program are described in the
individual files in /usr/share/doc/*/copyright.

Debian GNU/Linux comes with ABSOLUTELY NO WARRANTY, to the extent
permitted by applicable law.
pi@bpi-iot-ros-ai:~$ bpi-hw
bpi-m2p
pi@bpi-iot-ros-ai:~$ lscpu
Architecture:        armv7l
Byte Order:          Little Endian
CPU(s):              4
On-line CPU(s) list: 0-3
Thread(s) per core: 1
Core(s) per socket: 4
Socket(s):           1
CPU max MHz:         1200.0000
CPU min MHz:         648.0000
pi@bpi-iot-ros-ai:~$ uname -a
Linux bpi-iot-ros-ai 3.4.112-sun8i #2 SMP PREEMPT Mon May 30 20:34:33 CST 2016 armv7l GNU/Linux
pi@bpi-iot-ros-ai:~$ df -k
Filesystem      1K-blocks    Used Available Use% Mounted on
/dev/root       1656992 1356732    216000  87% /
devtmpfs        380000      0      380000   0% /dev
tmpfs           512036      0    512036   0% /dev/shm
tmpfs           512036     6900    505136   2% /run
tmpfs           5120      4        5116   1% /run/lock
tmpfs           512036      0    512036   0% /sys/fs/cgroup
/dev/mmcblk0p1  261868    212876    48992   82% /boot
pi@bpi-iot-ros-ai:~$ hcitool scan
Scanning ...
    D0:DF:C7:26:11:0C          n/a
    00:22:15:4C:6F:C9          WIN7USE-K7RHJ2U
    1C:87:2C:9B:DA:BC          ASUS_200AD
pi@bpi-iot-ros-ai:~$

```

1. based on RASPBIAN JESSIE LITE 2016-05-27(support rpi3 rpi2 rpi1)
2. BPI-M2P kernel 3.4.39 / kernel 3.4.112 (default)
3. username & password: pi/bananapi , root/bananapi
4. support HDMI 1080P & 720P(default)
5. support eMMC
6. support GMAC
7. support WIFI
8. support bpi-bootsel cmd can switch to (bpi-m64 & bpi-m3 & bpi-m2 & bpi-m2p & bpi-m1-m1p-r1)
9. support uEnv.txt to fatload script.bin & ulmage
10. support uEnv.txt to set video 1080P & 720P & 480P ...
11. fix rootmydevice issue
12. support BT (hcitool scan)
13. kernel 3.4.112 (based on armbian's build), thanks for armbian (<http://www.armbian.com>)
14. kernel 3.4.112 github from <https://github.com/igorpecovnik/lib> by armbian's work
15. thanks for raspberry.org's work(<https://www.raspberrypi.org/downloads/raspbian>)

Google Drive:

https://drive.google.com/file/d/0B_YnvHgh2rwdWp0bXRheHNJM1E/view?usp=sharing

MD5: 39646aa1fd070f3a74908cfb422d3b35

discuss on forum:

<http://forum.banana-pi.org/t/bpi-m2-new-image-raspbian-lite-bpi-m2p-img-2016-07-12/2002/2>

BPI-M2+ new image: Ubuntu-16.04-xenial-minimal-preview-bpi-m2p.img 2016-07-10

2016-07-10-ubuntu-16.04-xenial-minimal-preview-bpi-m2p.img.zip

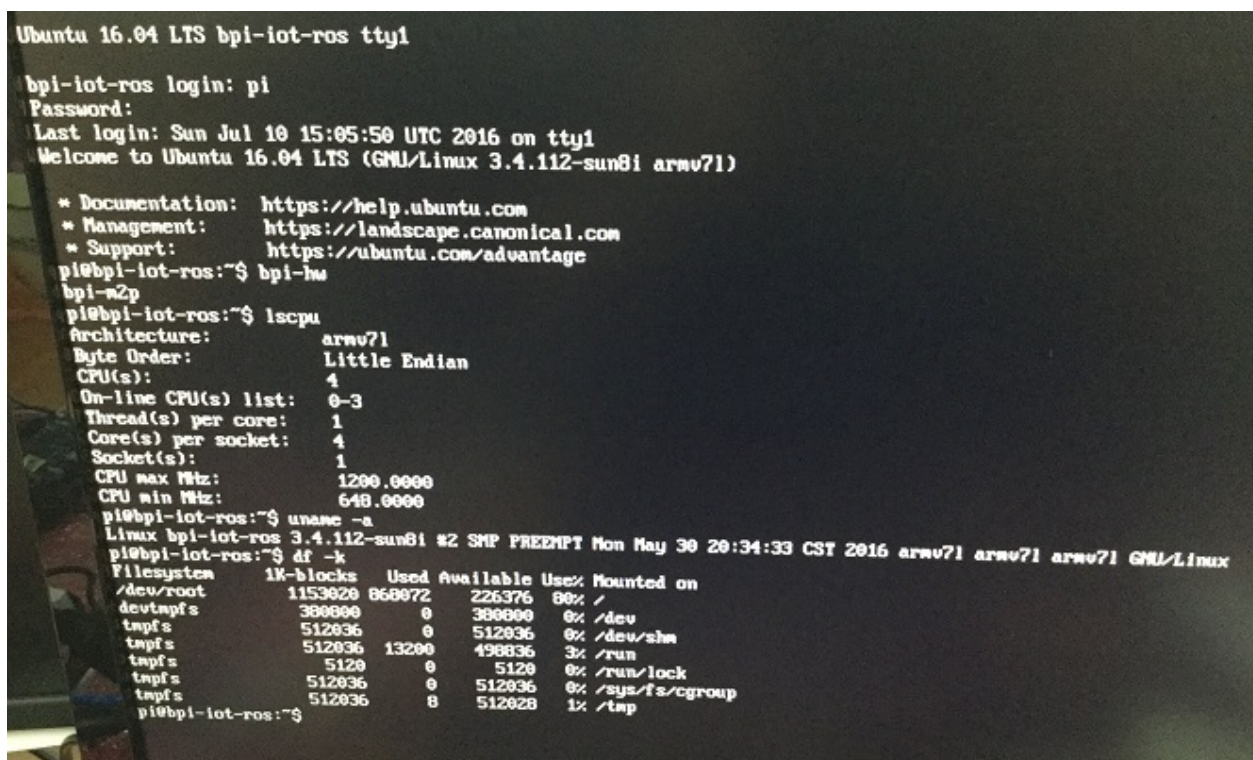

1. based on ubuntu 16.04 xenial ubuntu-minimal.
2. BPI-M2P kernel 3.4.39 / kernel 3.4.112 (default)
3. username & password: pi/bananapi , root/bananapi
4. support HDMI 1080P & 720P(default)
5. support eMMC
6. support GMAC
7. support WIFI (module only, no wireless tools)
8. support bpi-bootsel cmd can switch to (bpi-m64 & bpi-m3 & bpi-m2 & bpi-m2p & bpi-m1-m1p-r1)
9. support uEnv.txt to fatload script.bin & ulmage
10. support uEnv.txt to set video 1080P & 720P & 480P ...
11. fix rootmydevice issue
12. kernel 3.4.112 (based on armbian's build), thanks for armbian (<http://www.armbian.com>)
13. kernel 3.4.112 github from <https://github.com/igorpecovnik/lib> by armbian's work

Google Drive:

https://drive.google.com/file/d/0B_YnvHgh2rwdWp0bXRheHNJM1E/view?usp=sharing

MD5: ea5198fd12b006c953e2d59e7a29d431

OpenELEC-H3.arm-7.0-devel-20160510-preview-bpi-m2p-sd-emmc 2016-5-15

2016-05-15-OpenELEC-H3.arm-7.0-devel-20160510-preview-bpi-m2p-sd-emmc.img.zip



1. BPI-M2P kernel 3.4.112
2. OpenELEC 7.0
3. KODI v16.1 - Jarvis
4. support HDMI
5. support eMMC
6. support GMAC
7. support uEnv.txt to fatload script.bin & KERNEL & SYSTEM
8. fix rootmydevice issue
9. based on OpenELEC-H3, thanks for OpenELEC & jernej's build

issue:

WIFI & BT not ready

Google Drive:

https://drive.google.com/file/d/0B_YnvHgh2rwjODNPWHNzVIYwUFE/view?usp=sharing

MD5: ce597a8fcb93957f70cc2f702166c18e

discuss on forum :

<http://forum.banana-pi.org/t/bpi-m2-new-image-openelec-h3-arm-7-0-devel-20160510-preview-bpi-m2p-sd-emmc-2016-5-15/1697>

BPI-M2+ new image:Debian-8-jessie-mate-bpi-m2p-sd-emmc.img 2016-5-16

2016-05-16-debian-8-jessie-mate-bpi-m2p-sd-emmc.img.zip

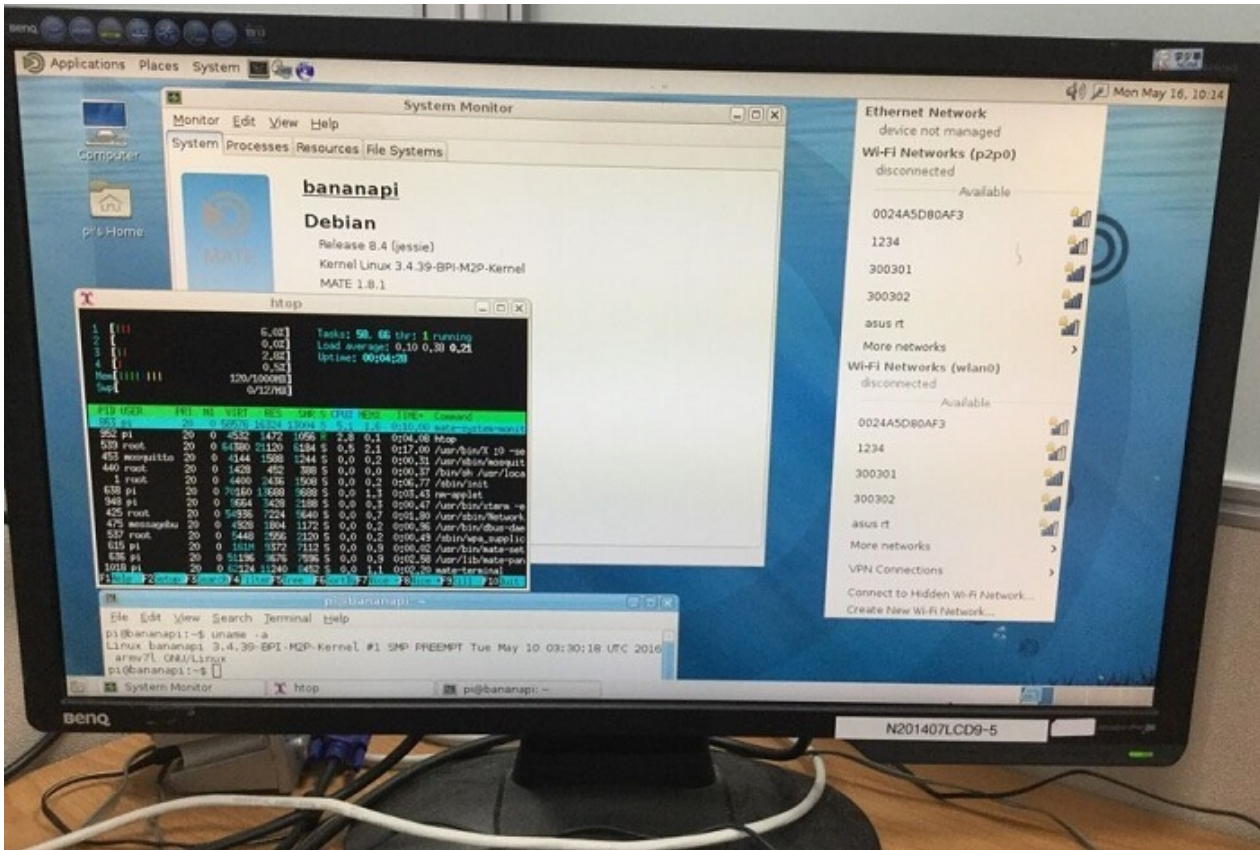

1. BPI-M2P kernel 3.4
2. username & password: root/bananapi
3. support HDMI 1080P & 720P(default)
4. support eMMC
5. support GMAC
6. support WIFI
7. support bpi-bootsel cmd can switch to (bpi-m3 & bpi-m2 & bpi-m2p)
8. support uEnv.txt to fatload script.bin & ulmage
9. support uEnv.txt to set video 1080P & 720P & 480P ...
10. fix rootmydevice issue
11. based on armbian rootfs, thanks for armbian

Google Drive:

https://drive.google.com/file/d/0B_YnvHgh2rwjSXltR0pCMXFkX00/view?usp=sharing

MD5: ea6660f5d3284c61e8950af6704bb76e

discuss on forum :

<http://forum.banana-pi.org/t/bpi-m2-new-image-debian-8-jessie-mate-bpi-m2p-sd-emmc-img-2016-5-16/1701>

Debian-8-jessie-lite-bpi-m2p-sd-emmc.img V1.1 2016-5-15

2016-05-15-debian-8-jessie-lite-bpi-m2p-sd-emmc.img.zip

```

Bananapi M2+

Welcome to ARMBIAN Debian GNU/Linux 8 (jessie) 3.4.39-BPI-M2P-Kernel

System load: 0.17          Up time:      1 min
Memory usage: 5 % of 1000Mb  IP:         192.168.11.4
CPU temp:    64 C
Usage of /:   21% of 6.9G

root@bananapi:~# bpi-bootset
bpi-bootset v1.0.4
usage: bpi-bootset
       bpi-bootset IMGFILE
       bpi-bootset IMGFILE DEVICE

bpi images:
/usr/lib/u-boot/bananapi/bpi-m2p/BPI_M2P_720P-openelec.img.gz
/usr/lib/u-boot/bananapi/bpi-m2p/BPI_M2P_720P.img.gz
/usr/lib/u-boot/bananapi/bpi-m2/BPI_M2_720P.img.gz
/usr/lib/u-boot/bananapi/bpi-m3/BPI_M3_720P.img.gz

Disks: (lsblk | grep disk)
mmcblk1boot0 179:32 0 4M 1 disk
mmcblk1boot1 179:48 0 4M 1 disk
mmcblk0      179:0 0 14.9G 0 disk
mmcblk1      179:16 0 7.3G 0 disk

Disks: (fdisk -l | grep Disk | grep bytes)
[ 87.971466] [mmc]: sdc2 set ios: clk 50000000Hz bm PP pm ON vdd 3.3V width 8 timing UHS-DDR50 dt B
[ 87.983589] [mmc]: sdc2 set ios: clk 50000000Hz bm PP pm ON vdd 3.3V width 8 timing UHS-DDR50 dt B
[ 87.995459] [mmc]: sdc2 set ios: clk 50000000Hz bm PP pm ON vdd 3.3V width 8 timing UHS-DDR50 dt B
Disk /dev/mmcblk0: 14.9 GiB, 15931539456 bytes, 31116288 sectors
Disk /dev/mmcblk1: 7.3 GiB, 7818182656 bytes, 15269888 sectors
Disk /dev/mmcblk1boot1: 4 MiB, 4194304 bytes, 8192 sectors
Disk /dev/mmcblk1boot0: 4 MiB, 4194304 bytes, 8192 sectors
root@bananapi:~#

```

1. BPI-M2P kernel 3.4
2. username & password: root/bananapi
3. support HDMI 1080P & 720P(default)
4. support eMMC
5. support GMAC
6. support WIFI
7. support bpi-bootset cmd can switch to (bpi-m3 & bpi-m2 & bpi-m2p)
8. support uEnv.txt to fatload script.bin & ulmage
9. support uEnv.txt to set video 1080P & 720P & 480P ...
10. fix rootmydevice issue
11. based on armbian rootfs, thanks for armbian

Google Drive:

https://drive.google.com/file/d/0B_YnvHgh2rwjQ1g5SG03bG9YYzg/view?usp=sharing

MD5: 93b9a4d16d55dc5e99795d8084f4f941

you can use bootset command to run it on BPI-M3, or run openelec on BPI-M2+

discuss on forum:

<http://forum.banana-pi.org/t/bpi-m2-new-image-debian-8-jessie-lite-bpi-m2p-sd-emmc-img-v1-1-2016-5-15/1699>

BPI-M2+ new image: Kali-xfce-bpi-m2p-sd-emmc.img 2016-5-12

2016-05-12-kali-xfce-bpi-m2p-sd-emmc.img.zip

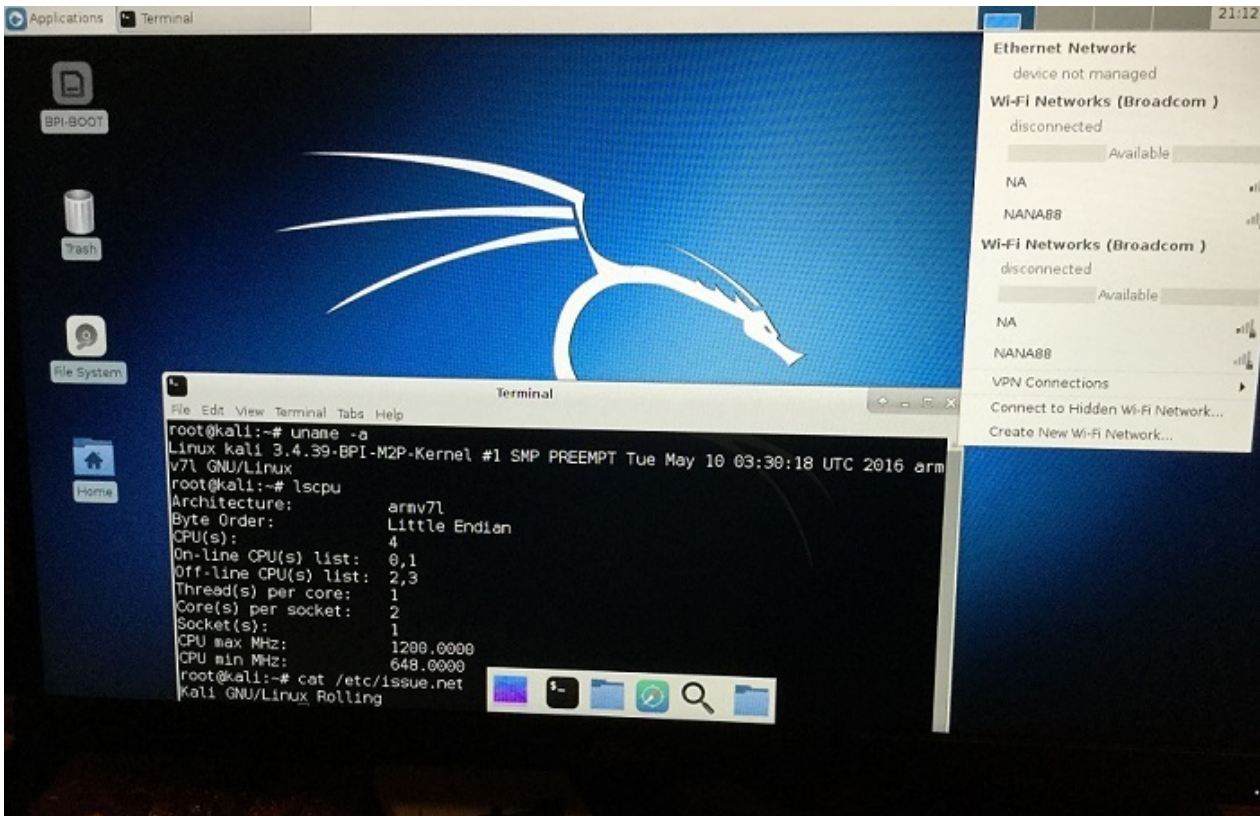

1. BPI-M2P kernel 3.4
2. username & password: root/bananapi
3. support HDMI 1080P & 720P(default)
4. support eMMC
5. support GMAC
6. support WIFI
7. support bpi-bootsel cmd can switch to (bpi-m3 & bpi-m2 & bpi-m2p)
8. support uEnv.txt to fatload script.bin & ulmage
9. support uEnv.txt to set video 1080P & 720P & 480P ...
10. fix rootmydevice issue

Google Drive:

https://drive.google.com/file/d/0B_YnvHgh2rwja0YtbDZFVm5hVmc/view?usp=sharing

MD5: 27f3532f9d067e44f2ad4623be36405d

discuss on forum:

<http://forum.banana-pi.org/t/bpi-m2-new-image-kali-xfce-bpi-m2p-sd-emmc-img-2016-5-12/1660>

BPI-M2+ new image: raspbian-jessie-mate-bpi-m2p-sd-emmc.img 2016-5-13

2016-05-13-raspbian-jessie-mate-bpi-m2p-sd-emmc.img.zip

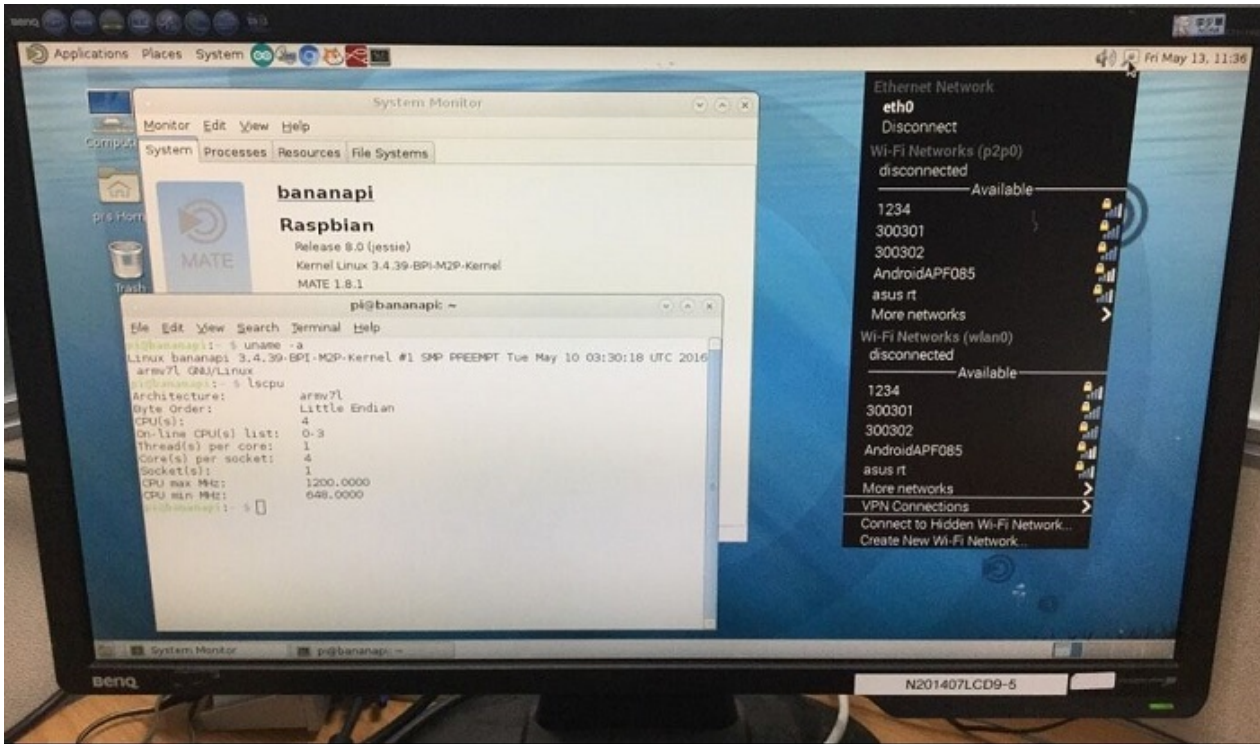

1. BPI-M2P kernel 3.4
2. username & password: pi/bananapi , root/bananapi
3. support HDMI 1080P & 720P(default)
4. support eMMC
5. support GMAC
6. support WIFI
7. support bpi-bootsel cmd can switch to (bpi-m3 & bpi-m2 & bpi-m2p)
8. support uEnv.txt to fatload script.bin & ulmage
9. support uEnv.txt to set video 1080P & 720P & 480P ...
10. fix rootmydevice issue

Google Drive:

https://drive.google.com/file/d/0B_YnvHgh2rwjQWxMSUImMnR6Rjg/view?usp=sharing

MD5: 3255de56840e56b2c9bb8210fdd3a4c6

<http://forum.banana-pi.org/t/bpi-m2-new-image-raspbian-jessie-mate-bpi-m2p-sd-emmc-img-2016-5-13/1658>

BPI-M2+ new image:centos-lite-preview-bpi-m2p.img 2016-5-12

2016-05-12-centos-lite-preview-bpi-m2p.img.zip

```
CentOS Linux 7 (Core)
Kernel 3.4.39-BPI-M2P-Kernel on an armv7l

centos-bananapi login: root
Password:
Last login: Thu Jan  1 08:02:56 on tty1
[root@centos-bananapi ~]# uname -a
Linux centos-bananapi 3.4.39-BPI-M2P-Kernel #1 SMP PREEMPT Tue May 10 03:30:18 UTC 2016 armv7l
[root@centos-bananapi ~]# lscpu
Architecture:        armv7l
Byte Order:          Little Endian
CPU(s):              4
On-line CPU(s) list: 0-3
Thread(s) per core:  1
Core(s) per socket:  4
Socket(s):           1
[root@centos-bananapi ~]# _
```

1. BPI-M2P kernel 3.4
2. username & password: root/bananapi
3. support HDMI 1080P & 720P(default)
4. support eMMC
5. support GMAC
6. support WIFI bcmhdhd module
7. support bpi-bootsel cmd can switch to (bpi-m3 & bpi-m2 & bpi-m2p)
8. support uEnv.txt to fatload script.bin & ulmage
9. support uEnv.txt to set video 1080P & 720P & 480P ...
10. fix rootmydevice issue

Google Drive:

https://drive.google.com/file/d/0B_YnvHgh2rwjWFhqdFZrWmJTOG8/view?usp=sharing

MD5: 6689f1e38eb57357bbc33407991d06be

discuss on forum:

<http://forum.banana-pi.org/t/bpi-m2-new-image-centos-lite-preview-bpi-m2p-img-2016-5-12/1659>

BPI-M2+ new image : gentoo-stage3-armv7a_lite-bpi-m2p-sd-emmc.img V1.0 2016-5-12

2016-05-12-gentoo-stage3-armv7a_lite-bpi-m2p-sd-emmc.img.zip

```

This is bananapi.banana-pi.org (Linux armv7l 3.4.39-BPI-M2P-Kernel) 15:42:18
bananapi login: root
Password:
Last login: Thu May 12 13:55:57 CST 2016 on tty1
bananapi ~ # uname -a
Linux bananapi 3.4.39-BPI-M2P-Kernel #1 SMP PREEMPT Tue May 10 03:30:18 UTC 2016 armv7l ARMv7 Processor rev 5 (v7l)
bananapi ~ # cat /etc/os-release
NAME=Gentoo
ID=gentoo
PRETTY_NAME="Gentoo/Linux"
ANSI_COLOR="1;32"
HOME_URL="http://www.gentoo.org/"
SUPPORT_URL="http://www.gentoo.org/main/en/support.xml"
BUG_REPORT_URL="https://bugs.gentoo.org/"
bananapi ~ # cat /etc/issue.logo

      .vir.
    d$$$$$$b .cd$$b. d$$b. d$$$$$$$$$$$$b d$$b. d$$b.
  $$$$ ( )$$$b d$$$ ( )$$$ d$$$$$$$$b Q$$$$$$$$T$$$P d$$b. d$$b.
 Q$$$$$$$$$$$$$$$$$$$$P d$$$PQ$$$$b. $$$$. $$$P. $$$ $$$$ $$$
  "$$$$$$$P Q$$$$$$$$b d$$$P Q$$$$b $$$b. $$$P. $$$ $$$ $$$$ $$$
 d$$$$$$$P" "$$$$$$$$ Q$$$ Q$$$$ $$$b $$$b. d$$$ $$$b. d$$$
 $$$b. $$$b. $$$b. $$$b. $$$b. $$$b. $$$b. $$$b. $$$b. $$$b. $$$b.
 Q$$$P"

This is \n.\0 (\s \n \r) \t
bananapi ~ # lsmod
Module                Size Used by
bcmhdhd                656647 0
bananapi ~ # lscpu
Architecture:          armv7l
Byte Order:            Little Endian
CPU(s):                4
On-line CPU(s) list:  0-3
Thread(s) per core:   1
Core(s) per socket:   4
Socket(s):              1
CPU max MHz:          1200.0000
CPU min MHz:           648.0000
bananapi ~ #

```

1. BPI-M2P kernel 3.4
2. username & password: root/bananapi
3. support HDMI 1080P & 720P(default)
4. support eMMC
5. support GMAC
6. support WIFI bcmhdhd module
7. support bpi-bootsel cmd can switch to (bpi-m3 & bpi-m2 & bpi-m2p)
8. support uEnv.txt to fatload script.bin & ulmage
9. support uEnv.txt to set video 1080P & 720P & 480P ...
10. fix rootmydevice issue

Google Drive:

https://drive.google.com/file/d/0B_YnvHgh2rwjenluaDhfZ2p4dmc/view?usp=sharing

MD5: d061987985a411fc8f6f9be341cb0c9a

discuss on forum:

<http://forum.banana-pi.org/t/bpi-m2-new-image-gentoo-stage3-armv7a-lite-bpi-m2p-sd-emmc-img-v1-0-2016-5-12/1647>

BPI-M2+ new image : OpenSUSE-Tumbleweed-ARM-Mate-bpi-m2p-sd-emmc 2016-05-011

2016-05-11-openSUSE-Tumbleweed-ARM-Mate-bpi-m2p-sd-emmc.img.zip

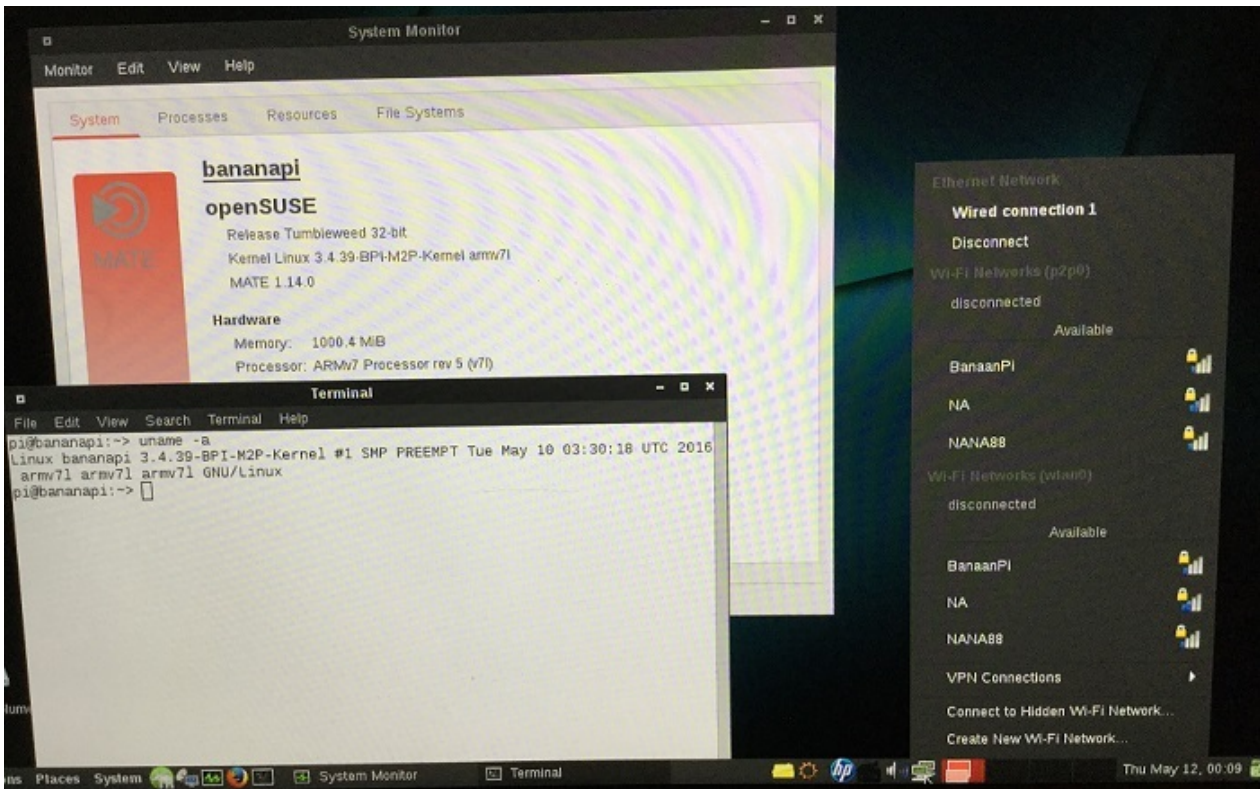

1. BPI-M2P kernel 3.4
2. username & password: pi/bananapi , root/bananapi
3. support HDMI 1080P & 720P(default)
4. support eMMC
5. support GMAC
6. support WIFI
7. support bpi-bootsel cmd can switch to (bpi-m3 & bpi-m2 & bpi-m2p)
8. support uEnv.txt to fatload script.bin & ulmage
9. support uEnv.txt to set video 1080P & 720P & 480P ...
10. fix rootmydevice issue

Google Drive:

https://drive.google.com/file/d/0B_YnvHgh2rwjMDJYMWdrVIR6Tkk/view?usp=sharing

MD5: 064d13cc5931307091b2ce392ab6a854

discuss on furom:

<http://forum.banana-pi.org/t/bpi-m2-new-image-opensuse-tumbleweed-arm-mate-bpi-m2p-sd-emmc-2016-05-011/1640>

BPI-M2+ new image : crux-arm-3.2-lite-bpi-m2p.img 2016-05-012

2016-05-12-crux-arm-3.2-lite-bpi-m2p.img.zip

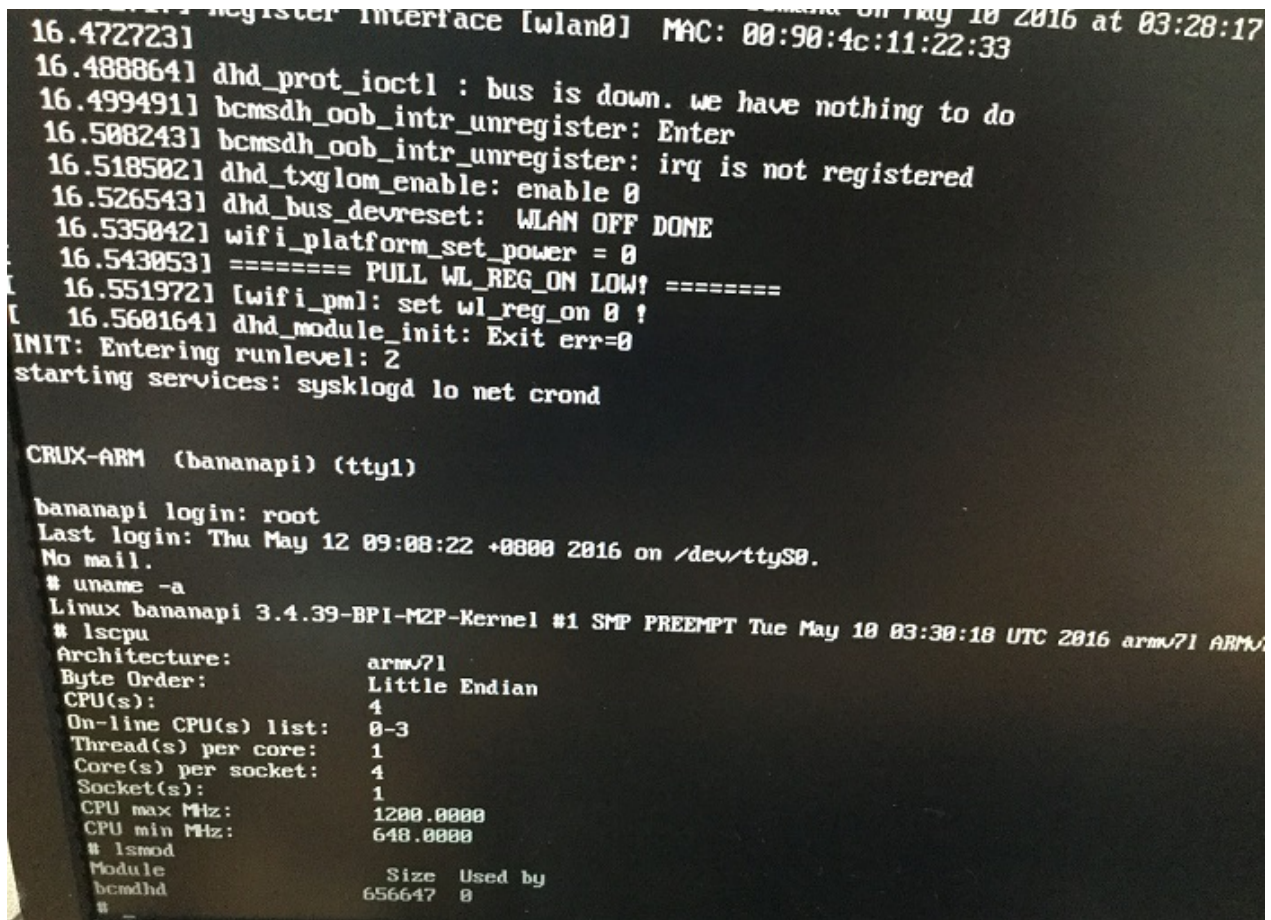

1. BPI-M2P kernel 3.4
2. username & password: root/bananapi
3. support HDMI 1080P & 720P(default)
4. support eMMC
5. support GMAC
6. support WIFI bcmshd module
7. support bpi-bootset cmd can switch to (bpi-m3 & bpi-m2 & bpi-m2p)
8. support uEnv.txt to fatload script.bin & ulmage
9. support uEnv.txt to set video 1080P & 720P & 480P ...
10. fix rootmydevice issue

Google Drive:

https://drive.google.com/file/d/0B_YnvHgh2rwjUkFubzNRNzJYbE0/view?usp=sharing

MD5: 5b869d564168658f949c902ec32cb971

discuss on forum:

<http://forum.banana-pi.org/t/bpi-m2-new-image-crux-arm-3-2-lite-bpi-m2p-img-2016-05-012/1642>

BPI-M2+ new image: Fedora-Mate-armhfp-23-10-bpi-m2p-sd-emmc 2016-5-11

2016-05-11-Fedora-Mate-armhfp-23-10-bpi-m2p-sd-emmc.img.zip

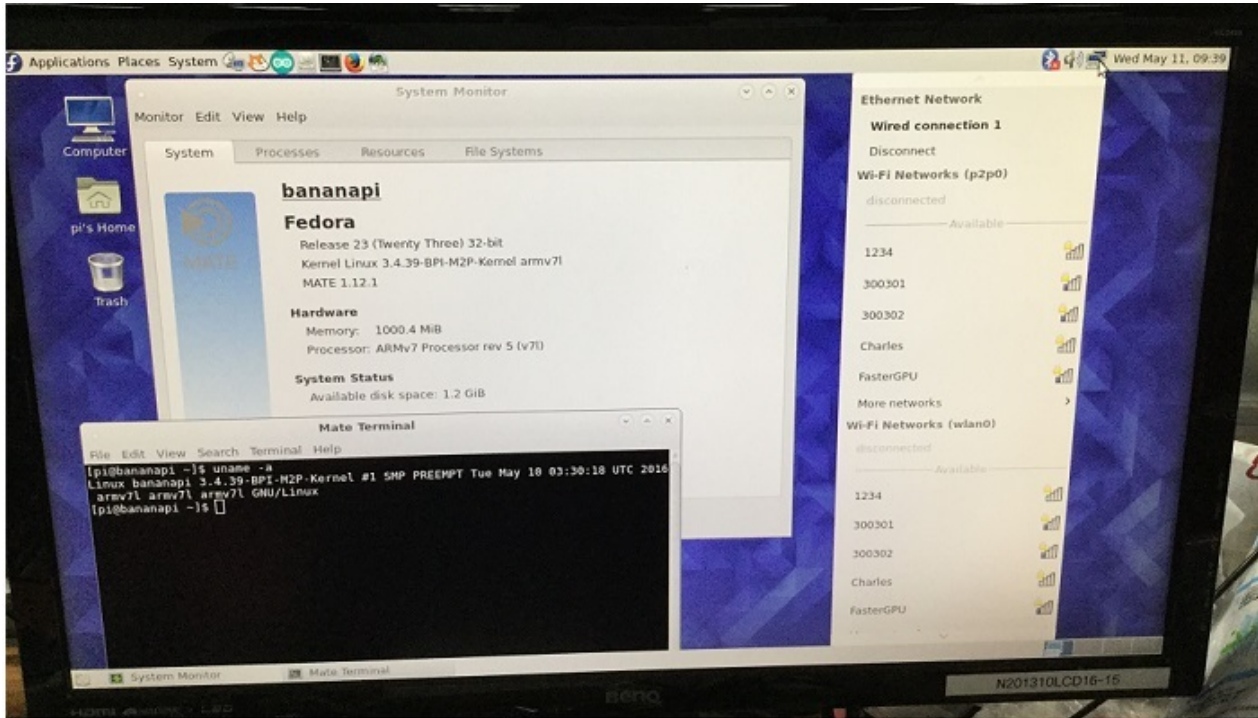

1. BPI-M2P kernel 3.4
2. username & password: pi/bananapi , root/bananapi
3. support HDMI 1080P & 720P(default)
4. support eMMC
5. support GMAC
6. support WIFI
7. support bpi-bootsel cmd can switch to (bpi-m3 & bpi-m2 & bpi-m2p)
8. support uEnv.txt to fatload script.bin & ulmage
9. support uEnv.txt to set video 1080P & 720P & 480P ...
10. fix rootmydevice issue

Google Drive:

https://drive.google.com/file/d/0B_YnvHgh2rwjcd0RFVPM25mNDQ/view?usp=sharing

MD5: efc1a119d0326f69ed2ee986d7a38a2e

discuss on forum:

<http://forum.banana-pi.org/t/bpi-m2-new-image-fedora-mate-armhfp-23-10-bpi-m2p-sd-emmc-2016-5-11/1638>

BPI-M2+ new image: ArchLinuxARM-lite-bpi-m2+ 2016-5-10

2016-05-10-ArchLinuxARM-lite-bpi-m2p.img.zip

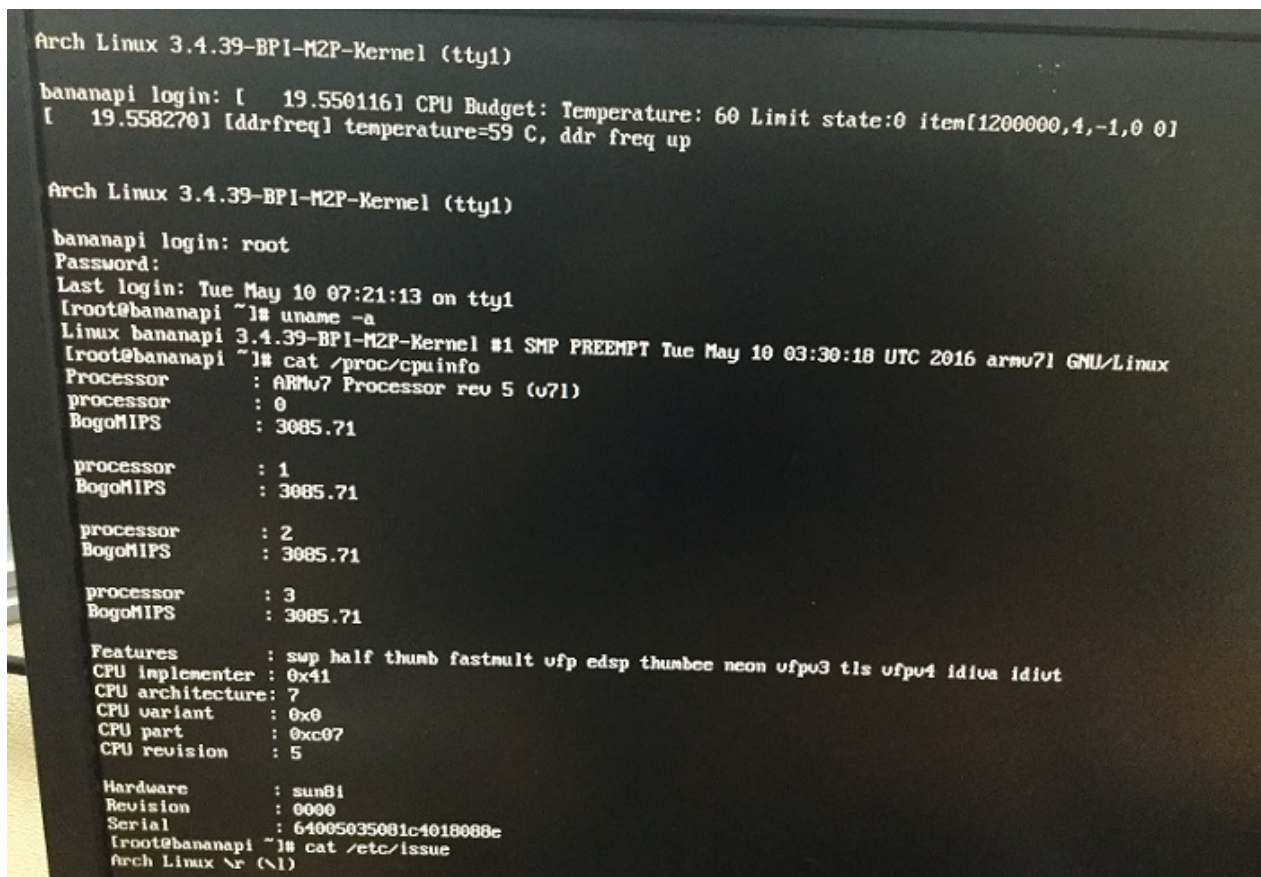

1. BPI-M2P kernel 3.4
2. username & password: root/bananapi
3. support HDMI 1080P & 720P(default)
4. support eMMC
5. support GMAC
6. support WIFI
7. support bpi-bootsel cmd can switch to (bpi-m3 & bpi-m2 & bpi-m2p)
8. support uEnv.txt to fatload script.bin & ulmage
9. support uEnv.txt to set video 1080P & 720P & 480P ...
10. fix rootmydevice issue

Google Drive:

https://drive.google.com/file/d/0B_YnvHgh2rwjMDd5N0dtNTVGYTA/view?usp=sharing

MD5: 4f60a9a32bac18c3f06918b0aee3b874

BPI-M2+ Ubuntu mate-16.04_Xenial mpv 1080p-bpi-m2p_preview 2016-05-05

2016-05-06-ubuntu-mate-16.04_Xenial_mpv_1080p-bpi-m2p_preview-sd-emmc.img.zip

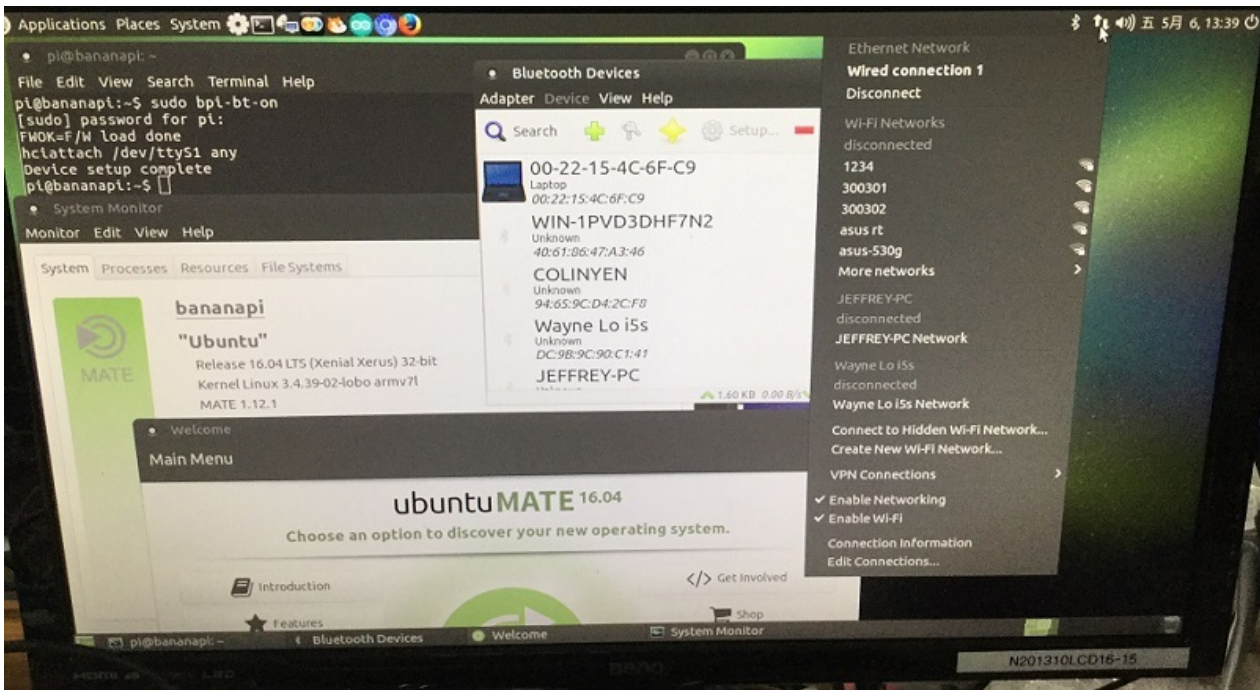

1. BPI-M2P kernel 3.4
2. username & password: pi/bananapi , root/bananapi
3. support HDMI 1080P & 720P(default)
4. support GMAC
5. support WIFI
6. support bpi-bootsel cmd can switch to (bpi-m3 & bpi-m2 & bpi-m2p)
7. support uEnv.txt to fatload script.bin & ulmage
8. support uEnv.txt to set video 1080P & 720P & 480P ...
9. support BT
10. support ov5640 camera
11. fix rootmydevice issue

issue:

- gpu not ready

Google Drive:

https://drive.google.com/file/d/0B_YnvHgh2rwjUHhRMI8zLWlwaDA/view?usp=sharing

MD5: 31a8e24abc76c2ba21a02ce399315b25

discuss on forum:

<http://forum.banana-pi.org/t/bpi-m2-ubuntu-mate-16-04-xenial-mpv-1080p-bpi-m2p-preview-2016-05-05/1610>

BPI-M2+ Ubuntu 15.10 gpu_vpu_camera_bt_bpi-m2p_beta V1.0 2016-05-05

2016-05-05-u1510_gpu_vpu_camera_bt_bpi-m2p_beta.img.zip

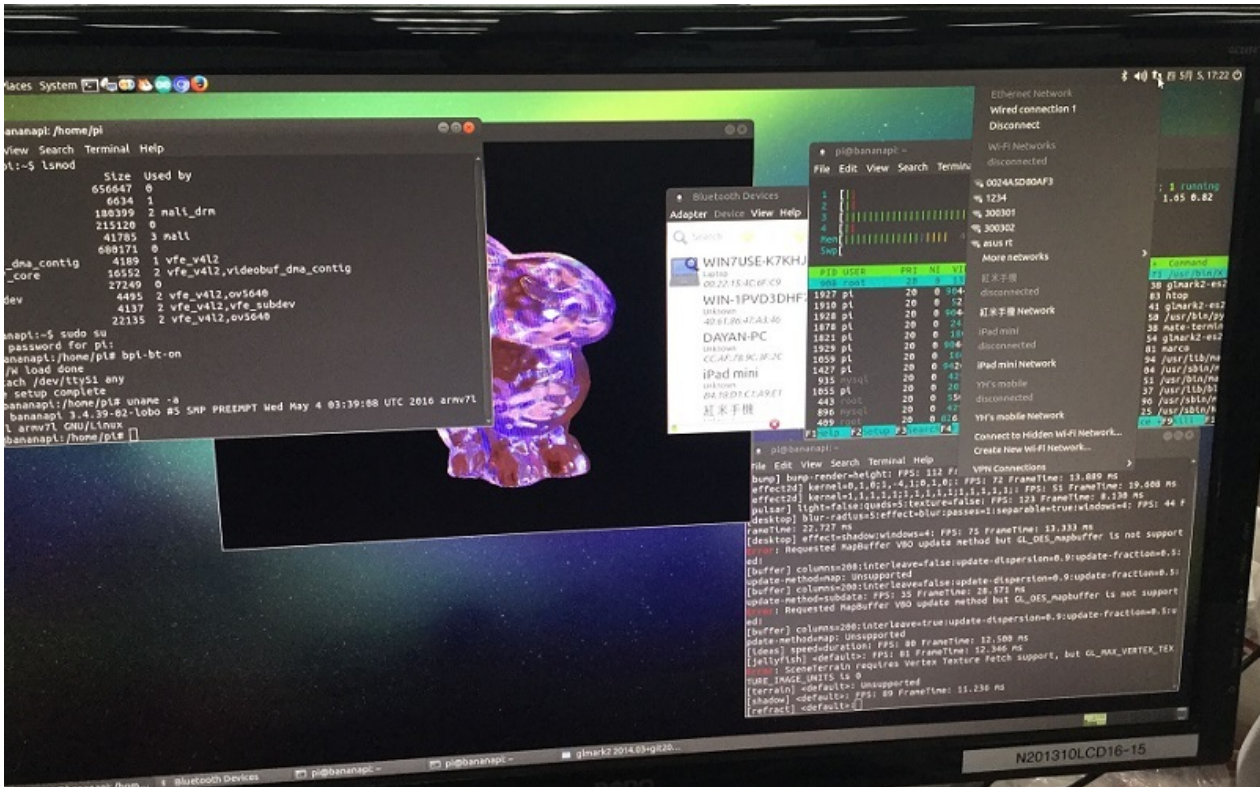

1. BPI-M2P kernel 3.4
2. username & password: pi/bananapi , root/bananapi
3. support HDMI 1080P & 720P(default)
4. support GMAC
5. support WIFI
6. support bpi-bootsel cmd can switch to (bpi-m3 & bpi-m2 & bpi-m2p)
7. support uEnv.txt to fatload script.bin & ulmage
8. support uEnv.txt to set video 1080P & 720P & 480P ...
9. support BT
10. support ov5640 camera
11. fix rootmydevice issue

Google Drive:

https://drive.google.com/file/d/0B_YnvHgh2rwm1dBNnYtaWUyOVU/view?usp=sharing

MD5: 25353a3d7c2fba11cb34b03b27f75ccf

discuss on forum:

<http://forum.banana-pi.org/t/bpi-m2-ubuntu-15-10-gpu-vpu-camera-bt-bpi-m2p-beta-v1-0-2016-05-05/1606>

BPI-M2+ Debian-8-jessie-lite-bpi-m2p_beta V1.0 2016-5-5

2016-05-05-debian-8-jessie-lite-bpi-m2p_beta-sd-emmc.img.zip

```

Welcome to ARMBIAN Debian GNU/Linux 8 (Jessie) 3.4.39-BPI-M3-Kernel

System load:  0.77          Up time:      41 sec
Memory usage: 3 % of 2011Mb IP:              172.20.10.8
CPU temp:    47°C
Usage of /:   90% of 1.6G

root@bananapi:~# uname -a
Linux bananapi 3.4.39-BPI-M3-Kernel #1 SMP PREEMPT Tue May 3 13:47:01 UTC 2016 armv7l GNU/Linux
root@bananapi:~# bpi-bootset
bpi-bootset v1.0.4
usage: bpi-bootset
       bpi-bootset IMGFILE
       bpi-bootset IMGFILE DEVICE

bpi images:
/usr/lib/u-boot/bananapi/bpi-m3/BPI_M3_720P.img.gz
/usr/lib/u-boot/bananapi/bpi-m2p/BPI_M2P_720P.img.gz
/usr/lib/u-boot/bananapi/bpi-m2/BPI_M2_720P.img.gz

Disks: (lsblk | grep disk)
mmcblk1boot0 179:32  0  4M  1 disk
mmcblk1boot1 179:48  0  4M  1 disk
mmcblk0      179:0   0 14.9G 0 disk
mmcblk1      179:16  0  7.3G 0 disk

Disks: (fdisk -l | grep Disk | grep bytes)
[ 216.662925] [mmc]: sdc2 set ios: clk 50000000Hz bm PP pm ON vdd 3.3V width 8 timing UHS-DDR50 dt B
[ 216.675064] [mmc]: sdc2 set ios: clk 50000000Hz bm PP pm ON vdd 3.3V width 8 timing UHS-DDR50 dt B
Disk /dev/mmcblk0: 14.9 GiB, 15931539456 bytes, 31116288 sectors
Disk /dev/mmcblk1: 7.3 GiB, 7818182656 bytes, 15269888 sectors
Disk /dev/mmcblk1boot1: 4 MiB, 4194304 bytes, 8192 sectors
Disk /dev/mmcblk1boot0: 4 MiB, 4194304 bytes, 8192 sectors
root@bananapi:~# bpi-bootset /usr/lib/u-boot/bananapi/bpi-m2p/BPI_M2P_720P.img.gz
Warning: Try to write /usr/lib/u-boot/bananapi/bpi-m2p/BPI_M2P_720P.img.gz to BOOTDISK /dev/mmcblk0
umount device: /dev/mmcblk0
OK!! You can reboot the system now!!
root@bananapi:~# _

```

1. BPI-M2P kernel 3.4
2. username & password: pi/bananapi , root/bananapi
3. support HDMI 1080P & 720P(default)
4. support GMAC
5. support WIFI
6. support bpi-bootset cmd can switch to (bpi-m3 & bpi-m2 & bpi-m2p)
7. support uEnv.txt to fatload script.bin & ulmage
8. support uEnv.txt to set video 1080P & 720P & 480P ...
9. fix rootmydevice issue
10. based on armbian rootfs, thanks for armbian

Google Drive:

https://drive.google.com/file/d/0B_YnvHgh2rwjQ1g5SG03bG9YYzg/view?usp=sharing

MD5: 09bc4970b824e1c938b1b0b53604633e

discuss on forum:

<http://forum.banana-pi.org/t/bpi-m2-debian-8-jessie-lite-bpi-m2p-beta-v1-0-2016-5-5/1607>

how to use banana pi BPI-M3 image on BPI-M2+ , use bpi-bootset

on BPI-M3 board: (login as root)

step 0: download https://github.com/BPI-SINOVOIP/BPI-files/blob/master/debs/linux-bananapi-bpi-m2p-kernel3_1.2.3_armhf.deb

step 1: `dpkg -i linux-bananapi-bpi-m2p-kernel3_1.2.3_armhf.deb`

step 2: `bpi-bootset /usr/lib/u-boot/bananapi/bpi-m2p/BPI_M2P_720P.img.gz`

step 3: `mkdir -p /boot/bananapi/bpi-m2p`

step 4: `cp -a /usr/lib/u-boot/bananapi/bpi-m2p/linux /boot/bananapi/bpi-m2p`

step 5: `cd /boot/bananapi/bpi-m2p/linux ; vi uEnv.txt` (if you want to change)

step 6: poweroff & remove SD card.on

BPI-M2+ board:

step 7: insert SD card and power on

log on BPI-M3:

```
root@bananapi:/# dpkg -l | grep bananapi
ii bananapi-bpi-tools          1.0.1
    armhf      Banaan Pi:  tools
ii linux-bananapi-bpi-m2-kernel3      1.2
    armhf      Banaan Pi BPI-M2:  linux kernel 3.3 image & modules
ii linux-bananapi-bpi-m3-kernel3      1.2.6
    armhf      Banaan Pi BPI-M3:  linux kernel 3.4 image & modules
ii linux-firmware-bananapi-bpi-wifi    1.0
    armhf      Banaan Pi: linux kernel firmware for wifi ap6181 & ap6212
root@bananapi:/# dpkg -i linux-bananapi-bpi-m2p-kernel3_1.2.3_armhf.deb
Selecting previously unselected package linux-bananapi-bpi-m2p-kernel3.
(Reading database ... 213272 files and directories currently installed.)
Preparing to unpack linux-bananapi-bpi-m2p-kernel3_1.2.3_armhf.deb ...
Unpacking linux-bananapi-bpi-m2p-kernel3 (1.2.3) ...
Setting up linux-bananapi-bpi-m2p-kernel3 (1.2.3) ...
root@bananapi:/# dpkg -l | grep bananapi
ii bananapi-bpi-tools          1.0.1
    armhf      Banaan Pi:  tools
ii linux-bananapi-bpi-m2-kernel3      1.2
    armhf      Banaan Pi BPI-M2:  linux kernel 3.3 image & modules
ii linux-bananapi-bpi-m2p-kernel3      1.2.3
    armhf      Banaan Pi BPI-M2P:  linux kernel 3.4 image & modules
ii linux-bananapi-bpi-m3-kernel3      1.2.6
    armhf      Banaan Pi BPI-M3:  linux kernel 3.4 image & modules
ii linux-firmware-bananapi-bpi-wifi    1.0
    armhf      Banaan Pi: linux kernel firmware for wifi ap6181 & ap6212
root@bananapi:/# bpi-bootset
usage: bpi-bootset v1.0.1
       bpi-bootset IMGFILE

bpi images:
/usr/lib/u-boot/bananapi/bpi-m2/BPI_M2_USB_LCD7.img.gz
/usr/lib/u-boot/bananapi/bpi-m2/BPI_M2_720P.img.gz
/usr/lib/u-boot/bananapi/bpi-m2/BPI_M2_USB_1080P.img.gz
/usr/lib/u-boot/bananapi/bpi-m2/BPI_M2_1080P.img.gz
/usr/lib/u-boot/bananapi/bpi-m2/BPI_M2_USB_720P.img.gz
/usr/lib/u-boot/bananapi/bpi-m2/BPI_M2_LCD7.img.gz
/usr/lib/u-boot/bananapi/bpi-m2p/BPI_M2P_720P.img.gz
/usr/lib/u-boot/bananapi/bpi-m3/BPI_M3_USB_720P.img.gz
/usr/lib/u-boot/bananapi/bpi-m3/BPI_M3_LCD7.img.gz
```



```

/usr/lib/u-boot/bananapi/bpi-m3/BPI_M3_720P.img.gz
/usr/lib/u-boot/bananapi/bpi-m3/BPI_M3_1080P.img.gz
/usr/lib/u-boot/bananapi/bpi-m3/BPI_M3_USB_LCD7.img.gz
/usr/lib/u-boot/bananapi/bpi-m3/BPI_M3_USB_1080P.img.gz
root@bananapi:/# bpi-bootse1 /usr/lib/u-boot/bananapi/bpi-m2p/BPI_M2P_720P.img.gz

Warning: Try to write /usr/lib/u-boot/bananapi/bpi-m2p/BPI_M2P_720P.img.gz to B0
OTDISK /dev/mmcblk0
OK!! You can reboot the system now!!
root@bananapi:/# df -k
Filesystem      1K-blocks    Used Available Use% Mounted on
/dev/root        7156088 5833956   958612  86% /
devtmpfs         767752      0    767752   0% /dev
tmpfs            1030072     676   1029396   1% /dev/shm
tmpfs            1030072    11404  1018668   2% /run
tmpfs             5120        4     5116   1% /run/lock
tmpfs            1030072      0   1030072   0% /sys/fs/cgroup
/dev/mmcblk0p1   261868     67512   194356  26% /boot
tmpfs            206016      36    205980   1% /run/user/1000
/dev/mmcblk1p2   7156088 5064340  1728228  75% /media/pi/BPI-ROOT
/dev/mmcblk1p1   261868     29556   232312  12% /media/pi/BPI-BOOT
tmpfs            206016      0    206016   0% /run/user/0
root@bananapi:/# ls -l /boot/bananapi/
bpi-m2p/                               sun7i-a20-bananapi-m1-plus.dtb
bpi-m3/                               sun7i-a20-bananapi-r1.dtb
sun6i-a31s-bananapi-m2.dtb            uboot/
sun6i-a31s-sinovoip-bpi-m2.dtb       uImage
sun7i-a20-bananapi.dtb
root@bananapi:/# rm -rf /boot/bananapi/bpi-m2p/
root@bananapi:/# ls -l /boot/bananapi/
bpi-m3/                               sun7i-a20-bananapi-m1-plus.dtb
sun6i-a31s-bananapi-m2.dtb            sun7i-a20-bananapi-r1.dtb
sun6i-a31s-sinovoip-bpi-m2.dtb       uboot/
sun7i-a20-bananapi.dtb               uImage
root@bananapi:/# mkdir -p /boot/bananapi/bpi-m2p
root@bananapi:/# cp -a /usr/lib/u-boot/bananapi/bpi-m2p/linux /boot/bananapi/bpi-
-m2p
cp: failed to preserve ownership for 000'/boot/bananapi/bpi-m2p/linux/script.bin
000': Operation not permitted
cp: failed to preserve ownership for 000'/boot/bananapi/bpi-m2p/linux/uEnv.txt '
: Operation not permitted
cp: failed to preserve ownership for 000'/boot/bananapi/bpi-m2p/linux000': Operati

```

video demo:

https://www.youtube.com/watch?v=aF_WZFDxGs4

mainline Linux image

BPI-M2 zero new image:2017-12-04-Ambian-5.36-m2-zero-Ubuntu-xenial-next-4.14.3-desktop-preview-buildbybpi

2017-12-04-Ambian_5.36_Bananapim2zero_Ubuntu_xenial_next_4.14.3_desktop_preview_build_by_bpi.img.img.zip



1. based on ubuntu 16.04.3 LTS Xfce Desktop build with armbian's work by bpi
2. support BPI-M2 Zero (H3 / H2+) , u-boot 2017.11 , kernel 4.14.3
3. username & password: root/1234 (armbian default)
4. support HDMI (default)
5. support WIFI
6. support OTG (can support usb hub & usb ethernet)
7. support DVFS (pmu type: gpio PL01 switch 1.1V / 1.3V)
8. Thanks for linux-sunxi community (<http://linux-sunxi.org/>)
9. Thanks to armbian's work (<https://www.armbian.com/>)
10. ref. patch files (<https://github.com/BPI-SINOVOIP/BPI-files/tree/master/others/armbian>)
11. ref. <https://github.com/BPI-SINOVOIP/BPI-M2Z-bsp>
12. ref. <https://bananapi.gitbooks.io/bpi-m2-/content/en/>

Google Drive:

https://drive.google.com/file/d/1CisTYS1iJ3kV645_SJ74RSL-sknKNzB6/view?usp=sharing

baidu cloud:

<https://pan.baidu.com/s/1dEKd1qL>

MD5: 5827f42c79840378c980fb9794143c63

FILESIZE: 823252037 (~785MB)

discuss on forum:

<http://forum.banana-pi.org/t/bpi-m2-zero-new-image-2017-12-04-armbian-5-36-m2-zero-ubuntu-xenial-next-4-14-3-desktop-preview-buildbybpi/4325>

BPI-M2 Zero new image:2017-12-03-Ambian-5.36-m2-zero-Ubuntu-xenial-next-4.14.3-preview-buildbyBPI

2017-12-03-Ambian_5.36_Bananapim2zero_Ubuntu_xenial_next_4.14.3_preview_build_by_bpi.img.zip



1. based on ubuntu server 16.04.3 LTS build with armbian's work by bpi
2. support BPI-M2 Zero (H3 / H2+) , u-boot 2017.11 , kernel 4.14.3
3. username & password: root/1234 (armbian default)
4. support HDMI (default)
5. support WIFI
6. support OTG (can support usb hub & usb ethernet)

7. support DVFS (pmu type: gpio PL01 switch 1.1V / 1.3V)
8. Thanks for linux-sunxi community (<http://linux-sunxi.org/>)
9. Thanks to armbian's work (<https://www.armbian.com/>)
10. ref. patch files (<https://github.com/BPI-SINOVOIP/BPI-files/tree/master/others/armbian>)
11. ref. <https://github.com/BPI-SINOVOIP/BPI-M2Z-bsp>
12. ref. <https://bananapi.gitbooks.io/bpi-m2-/content/en/>

Google Drive:

https://drive.google.com/file/d/1hrtg0hXrVs1OUNyIQ_mTq6dAFdYFQemP/view?usp=sharing

baidu cloud:

<https://pan.baidu.com/s/1chkkBO>

MD5: e516875dcccfe721e509182a7f2652944

FILESIZE: 365349636 (~348MB)

UNPACK: ~1412MB (will auto resize after setup)

discuss on forum:

<http://forum.banana-pi.org/t/bpi-m2-zero-new-image-2017-12-03-armbian-5-36-m2-zero-ubuntu-xenial-next-4-14-3-preview-buildbybpi/4324>

.

Mainline uboot

start with [Sinovoip_BPI_M2_plus_defconfig](#) (tested with 2016.03 and sun8i-h3-bananapi-m2plus.dts from below).

It can boot from eMMC, the SD card or via [FEL](#).

BPI-M2+ mainline kernel

Initial H3 patches have been submitted to the mainline kernel, but have not landed yet. Currently you can find these patches in the arm-linux mailing list, or alternatively in one of the work-in-progress kernel forks:

- Maxime Ripard's branch 'sunxi/for-next' at <https://git.kernel.org/cgit/linux/kernel/git/mripard/linux.git/log/?h=sunxi/for-next> (very basic H3 support, without USB)
- Hans de Goede's branch 'sunxi-wip' at <https://github.com/jwrdegoede/linux-sunxi/tree/sunxi-wip> (many work-in-progress patches, including H3 and USB support for it)
- Siarhei Siamashka's branch '20151223-h3-mainline-smp-hack' at <https://github.com/ssvb/linux-sunxi/tree/20151223-h3-mainline-smp-hack> (minimal set of H3 patches, with USB and SMP)

sun8i-h3-bananapi-m2plus.dts:<http://pastebin.com/sKfj2tTW> (everything working except of WiFi/BT due to lack of interest)

BPI-M2+ (BPI-M2Plus) WiringPi

BPI WiringPi support all raspberry pi module and all banana pi module :BPI-M1,BPI-M1+,BPI-R1,BPI-M2,BPI-M2+,BPI-M2 Ultra,BPI-M2 Magic,BPI-M3,BPI-M64

<https://github.com/BPI-SINOVOIP/WiringPi>

<https://github.com/BPI-SINOVOIP/WiringPi/tree/master/wiringPi/board>

install BPI-M2+ WiringPi:

1 · Download WiringPi from github For BPI-M2+

```
git clone https://github.com/BPI-SINOVOIP/BPI-WiringPi.git -b BPI_M2p
```

2 · Installation :

```
cd BPI-WiringPi
```

```
chmod +x ./build
```

```
sudo ./build
```

3 · test wiringPi is install success

```
gpio -v
```

```
pi@bananapi:~$ gpio -v
gpio version: 2.26
Copyright (c) 2012-2015 Gordon Henderson
This is free software with ABSOLUTELY NO WARRANTY.
For details type: gpio -warranty

Banana Pi Details:
  Type: Model BM, Revision: 1.2, Memory: 2048MB, Maker: BPI
pi@bananapi:~$
```

banana-pi.org.cn
香蕉派官方创客社区

```
gpio readall
```

```
pi@bananapi:~$ gpio readall
```

Pi											
CPU	wPi	Name	Mode	V	Physical	V	Mode	Name	wPi	CPU	
		3.3v			1	2		5v			
229	8	SDA.1	ALT5	0	3	4		5V			
228	9	SCL.1	ALT5	0	5	6		GND			
362	7	GCLK	ALT5	0	7	8	0	ALT5	TxD0	15	32
		GND			9	10	0	ALT5	RxD0	16	33
68	0	GEN0	ALT3	0	11	12	0	ALT5	GEN1	1	35
71	2	GEN2	ALT3	0	13	14			GND		
81	3	GEN3	ALT3	0	15	16	0	ALT5	GEN4	4	34
		3.3v			17	18	0	ALT3	GEN5	5	360
64	12	MOSI	ALT3	0	19	20			GND		
65	13	MISO	ALT3	0	21	22	0	OUT	GEN6	6	361
66	14	SCLK	ALT3	0	23	24	0	ALT3	CE0	10	67
		GND			25	26	0	ALT3	CE1	11	234
227	30	SDA.0	ALT5	0	27	28	0	ALT5	SCL.0	31	226
82	21	GPIO.21	ALT3	0	29	30			GND		
202	22	GPIO.22	ALT3	0	31	32	0	ALT3	GPIO.26	26	205
203	23	GPIO.23	ALT3	0	33	34			GND		
204	24	GPIO.24	ALT3	0	35	36	0	ALT3	GPIO.27	27	133
132	25	GPIO.25	ALT3	0	37	38	0	ALT3	GPIO.28	28	146
		GND			39	40	0	ALT3	GPIO.29	29	147

banana-pi.org.cn
香蕉派官方创客社区

4 · create new : blink.c

```
#include <wiringPi.h>
int main(void)
{
    wiringPiSetup();
    pinMode(0, OUTPUT);
    for(;;)
    {
        digitalWrite(0, HIGH); delay(500);
        digitalWrite(0, LOW); delay(500);
    }
}
```

compile and run it:

```
gcc -Wall -o blink blink.c -lwiringPi
```

runing it:

```
sudo ./blink
```

BPI have many extend board support WiringPi. so you can free DIY by yourself:

more about BPI extend board,please see:

<https://bananapi.gitbooks.io/bpi-accessories/content/>

OpenWRT on banana pi

OpenWRT have support many allwinner chip . so easy to use it on banana pi

Allwinner Sun4i/5i/6i/7i/9i (sunxi) Various vendors are offering development boards / [single-board computer](#) based on the [Allwinner SoCs](#). These are running various flavors of the A1x, A20, A31, and soon H3 SoCs, with different buildouts. The mach is called "sunxi".

For some specs rather see [Allwinner_Technology#A-Series](#).

Supported Versions

Model Version	Launch Date	OpenWrt Version Supported	Model Specific Notes
A10	-	CC/trunk	Single Cortex-A8
A10s	-	CC/trunk	Single Cortex-A8
A13	-	CC/trunk	Single Cortex-A8
A20	-	CC/trunk	Dual Cortex-A7
A23	-	na	Dual Cortex-A7
A31	-	trunk	Quad Cortex-A7
A33	-	na	Quad Cortex-A7
A80	-	na	8-core big.LITTLE (4x A15 + 4x A7)
H3	-	trunk	Quad-core Cortex-A7
H8	-	na	8-core Cortex-A7

more please see:

[https://wiki.openwrt.org/doc/hardware/soc/soc.allwinner.sunxi?s\[\]=banana&s\[\]=pi](https://wiki.openwrt.org/doc/hardware/soc/soc.allwinner.sunxi?s[]=banana&s[]=pi)

BPI-tools

[bpi-tools]: v1.0.3: bpi-tools bpi-get cmd support update tools & download images

bpi-tools can install to X86 ubuntu and Banana Pi:

on x86 pc: for ubuntu 14.04 (x86): `dpkg --add-architecture armhf` or for ubuntu 12.04 (x86): `echo "foreign-architecture armhf" >> /etc/dpkg/dpkg.cfg.d/multiarch`

```
dpkg -i bananapi-bpi-tools*.deb
```

if you don't have pv cmd: `apt-get install pv` (for bpi-copy use)

download bpi-tools & install:

on ubuntu / raspbian / debian :

download file: `bananapi-bpi-tools_1.0.3_armhf.deb`

github: https://github.com/BPI-SINOVOIP/BPI-files/raw/master/debs/bananapi-bpi-tools_1.0.3_armhf.deb

google drive: https://drive.google.com/file/d/0B_YnvHgh2rwjc29jNVdoaDNXRUU/view?usp=sharing

MD5: 0408a434003651001f0131e61cad2fd

```
# sudo dpkg -i bananapi-bpi-tools_1.0.3_armhf.deb
```

on other system :

download file: `bpi-tools.tgz`

google drive: https://drive.google.com/file/d/0B_YnvHgh2rwjMGZOZC1Gd3dwQkE/view?usp=sharing

MD5: 82e35dba52bc3edb48e96c8a544ac216

```
# sudo tar xvf bpi-tools.tgz -C /
```

HOW TO USE:

```

root@bananapi:~# bpi-tools
    bpi-tools v1.0.6
usage: bpi-tools
    bpi-tools FILE
    bpi-tools --all | --update | --download | --version

```

bpi files:

```

bpi-tools      v1.0.6
bpi-bootssel   v1.0.4
bpi-copy       v1.0.10a
bpi-get        v1.0.3

```

```

root@bananapi:~# bpi-tools --update

```

```

    bpi-tools v1.0.6
usage: bpi-tools
    bpi-tools FILE
    bpi-tools --all | --update | --download | --version

```

```

BPIFILE=/root/.bpi-tools.lst

```

Wait for download index file ...

OK!!\n

bpi files:

```

bpi-tools      v1.0.6
bpi-bootssel   v1.0.4
bpi-copy       v1.0.10a
bpi-get        v1.0.3

```

```

root@bananapi:~# bpi-tools --version

```

bpi files:

```

/usr/bin/bpi-tools      v1.0.6
/usr/bin/bpi-bootssel   v1.0.4
/usr/bin/bpi-copy       v1.0.10a
/usr/bin/bpi-get        v1.0.3

```

```

root@bananapi:~# bpi-tools --download

```

download bpi files:

```

bpi-tools
bpi-tools: OK
bpi-tools: v1.0.6
bpi-bootssel
bpi-bootssel: OK
bpi-bootssel: v1.0.4
bpi-copy
bpi-copy: OK
bpi-copy: v1.0.10a
bpi-get
bpi-get: OK
bpi-get: v1.0.3

```

```

root@bananapi:~# ls -l

```

```

total 20
-rwxr-xr-x 1 root root 1493 5月 6 10:06 bpi-bootssel
-rwxr-xr-x 1 root root 6170 5月 6 10:06 bpi-copy
-rwxr-xr-x 1 root root 1391 5月 6 10:06 bpi-get
-rwxr-xr-x 1 root root 2898 5月 6 10:06 bpi-tools

```

```

root@bananapi:~# bpi-get

```

```

    bpi-get v1.0.3
usage: bpi-get
    bpi-get FILE

```

```

BPIFILE=/root/.bpi-files.lst

```

Wait for download index file ...

bpi files: 2016-05-05-u1510_gpu_vpu_camera_bt_bpi-m2p_beta.img.zip 2016-05-05-debian-8-jessie-lite-bpi-m2p_beta-sd-
emmc.img.zip 2016-04-27-debian-8-jessie-mate_gpu_mpv_1080p-bpi-m3_beta-sd-emmc.img.zip 2016-04-25-ubuntu-
mate-16.04_Xenial_gpu_mpv_1080p_bt-bpi-m3_beta-sd-emmc.img.zip u1510_gpu_vpu_camera_bpi-m2p-

20160413_preview.img.zip 2016-04-11-Ambian_5.07_Bananapim2plus_Debian_jessie_3.4.111_desktop_preview.img.zip
 2016-04-08-raspbian-jessie-bpi-m2.img.zip 2016-04-08-raspbian-jessie-bpi-m2p.img.zip 2016-04-08-raspbian-jessie-bpi-
 m3.img.zip

```

root@bananapi:~# bpi-get 2016-05-05-debian-8-jessie-lite-bpi-m2p_beta-sd-emmc.img.zip
INFO: Try to get 2016-05-05-debian-8-jessie-lite-bpi-m2p_beta-sd-emmc.img.zip ...
BPIFILE=/root/.bpi-files.lst
IMGFILE=2016-05-05-debian-8-jessie-lite-bpi-m2p_beta-sd-emmc.img.zip
MD5TMP=/tmp/.md5.tmp.8322
  % Total    % Received % Xferd  Average Speed   Time    Time     Time  Current
                                 Dload  Upload   Total   Spent    Left   Speed
100  280    0  280    0    0    430      0  --:--:--  --:--:--  --:--:--  430
   0    0    0 671M    0    0 3317k    0  --:--:--  0:03:27  --:--:-- 3533k
2016-05-05-debian-8-jessie-lite-bpi-m2p_beta-sd-emmc.img.zip: OK
root@bananapi:~# bpi-copy .
SRC=.
DST=
COPYMODE=usage
default
    bpi-copy v1.0.10a
usage: bpi-copy
    bpi-copy IMGFILE
    bpi-copy IMGDIR
    bpi-copy IMGFILE DEVICE
    bpi-copy DEVICE IMGFILE

bpi images: (*.img.zip)
./2016-05-05-debian-8-jessie-lite-bpi-m2p_beta-sd-emmc.img.zip
bpi images: (*.img)
bpi images: (*.img.gz)
/usr/lib/u-boot/bananapi/bpi-m2/BPI_M2_720P.img.gz
/usr/lib/u-boot/bananapi/bpi-m2p/BPI_M2P_720P.img.gz
/usr/lib/u-boot/bananapi/bpi-m3/BPI_M3_720P.img.gz
/usr/lib/u-boot/bananapi/u-boot-2016.05-rc1/u-boot-2016.05-rc1-bpi-m1.img.gz
/usr/lib/u-boot/bananapi/u-boot-2016.05-rc1/u-boot-2016.05-rc1-bpi-m1p.img.gz
/usr/lib/u-boot/bananapi/u-boot-2016.05-rc1/u-boot-2016.05-rc1-bpi-m2.img.gz
/usr/lib/u-boot/bananapi/u-boot-2016.05-rc1/u-boot-2016.05-rc1-bpi-m2p.img.gz
/usr/lib/u-boot/bananapi/u-boot-2016.05-rc1/u-boot-2016.05-rc1-bpi-m3.img.gz
/usr/lib/u-boot/bananapi/u-boot-2016.05-rc1/u-boot-2016.05-rc1-bpi-r1.img.gz
xz images: (*.xz)
zip images: (*.zip)
./2016-05-05-debian-8-jessie-lite-bpi-m2p_beta-sd-emmc.img.zip
raw images: (*.raw)

Disks: (lsblk | grep disk)
sda      8:0    0 931.5G  0 disk
sdb      8:16   0  2.7T   0 disk
sdc      8:32   1  14.9G  0 disk

Disks: (fdisk -l | grep Disk | grep bytes)
Disk /dev/sda: 1000.2 GB, 1000204886016 bytes
Disk /dev/sdb: 3000.6 GB, 3000558944256 bytes
Disk /dev/sdc: 15.9 GB, 15931539456 bytes
root@bananapi:~# bpi-copy ./2016-05-05-debian-8-jessie-lite-bpi-m2p_beta-sd-emmc.img.zip /dev/sdc
SRC=./2016-05-05-debian-8-jessie-lite-bpi-m2p_beta-sd-emmc.img.zip
DST=/dev/sdc
COPYMODE=imagetodisk
imagetodisk
    bpi-copy v1.0.10a
usage: bpi-copy
    bpi-copy IMGFILE
    bpi-copy IMGDIR
    bpi-copy IMGFILE DEVICE
    bpi-copy DEVICE IMGFILE

Warning: Try to write ./2016-05-05-debian-8-jessie-lite-bpi-m2p_beta-sd-emmc.img.zip to BOOTDISK /dev/sdc
=====
五  5月  6 10:21:13 CST 2016
*** start COPY (blue led on ) .....
umount device: /dev/sdc
umount /dev/sdc2

```

```

umount /dev/sdc1
=====
IMGFILE=./2016-05-05-debian-8-jessie-lite-bpi-m2p_beta-sd-emmc.img.zip
=====
zip
1.91GB 0:01:59 [16.3MB/s] [          <=>          ]
0+20666 records in
0+20666 records out
*** end COPY (blue led off) .....
五 五月 6 10:23:40 CST 2016
=====
RUNTIME 2:27
OK!! You can remove the BOOTDISK /dev/sdc now!!
root@bananapi:~#

```

if you want to use bpi-m2p image for bpi-m3, you can re-insert SD card:

```

root@bananapi:~# bpi-bootsetl
    bpi-bootsetl v1.0.4
usage: bpi-bootsetl
    bpi-bootsetl IMGFILE
    bpi-bootsetl IMGFILE DEVICE

bpi images:
/usr/lib/u-boot/bananapi/u-boot-2016.05-rc1/u-boot-2016.05-rc1-bpi-m1.img.gz
/usr/lib/u-boot/bananapi/u-boot-2016.05-rc1/u-boot-2016.05-rc1-bpi-m2.img.gz
/usr/lib/u-boot/bananapi/u-boot-2016.05-rc1/u-boot-2016.05-rc1-bpi-m1p.img.gz
/usr/lib/u-boot/bananapi/u-boot-2016.05-rc1/u-boot-2016.05-rc1-bpi-m2p.img.gz
/usr/lib/u-boot/bananapi/u-boot-2016.05-rc1/u-boot-2016.05-rc1-bpi-r1.img.gz
/usr/lib/u-boot/bananapi/u-boot-2016.05-rc1/u-boot-2016.05-rc1-bpi-m3.img.gz
/usr/lib/u-boot/bananapi/bpi-m2/BPI_M2_720P.img.gz
/usr/lib/u-boot/bananapi/bpi-m2p/BPI_M2P_720P.img.gz
/usr/lib/u-boot/bananapi/bpi-m3/BPI_M3_720P.img.gz

Disks: (lsblk | grep disk)
sda      8:0      0 931.5G  0 disk
sdb      8:16     0  2.7T   0 disk
sdc      8:32     1 14.9G   0 disk

Disks: (fdisk -l | grep Disk | grep bytes)
Disk /dev/sda: 1000.2 GB, 1000204886016 bytes
Disk /dev/sdb: 3000.6 GB, 3000558944256 bytes
Disk /dev/sdc: 15.9 GB, 15931539456 bytes
root@bananapi:~# bpi-bootsetl /usr/lib/u-boot/bananapi/bpi-m3/BPI_M3_720P.img.gz /dev/sdc
Warning: Try to write /usr/lib/u-boot/bananapi/bpi-m3/BPI_M3_720P.img.gz to BOOTDISK /dev/sdc
umount device: /dev/sdc
umount /dev/sdc2
umount /dev/sdc1
OK!! You can remove the BOOTDISK /dev/sdc now!!
root@bananapi:~#

```

bpi-bootset command

How to use bpi-bootset command (Multi-use SD card supported)

From now on, just download either M2 or M3, then you can switch to any of them as you wish!

bpi-bootset v1.0.5

```
usage: bpi-bootset
       bpi-bootset IMGFILE
       bpi-bootset IMGFILE DEVICE
```

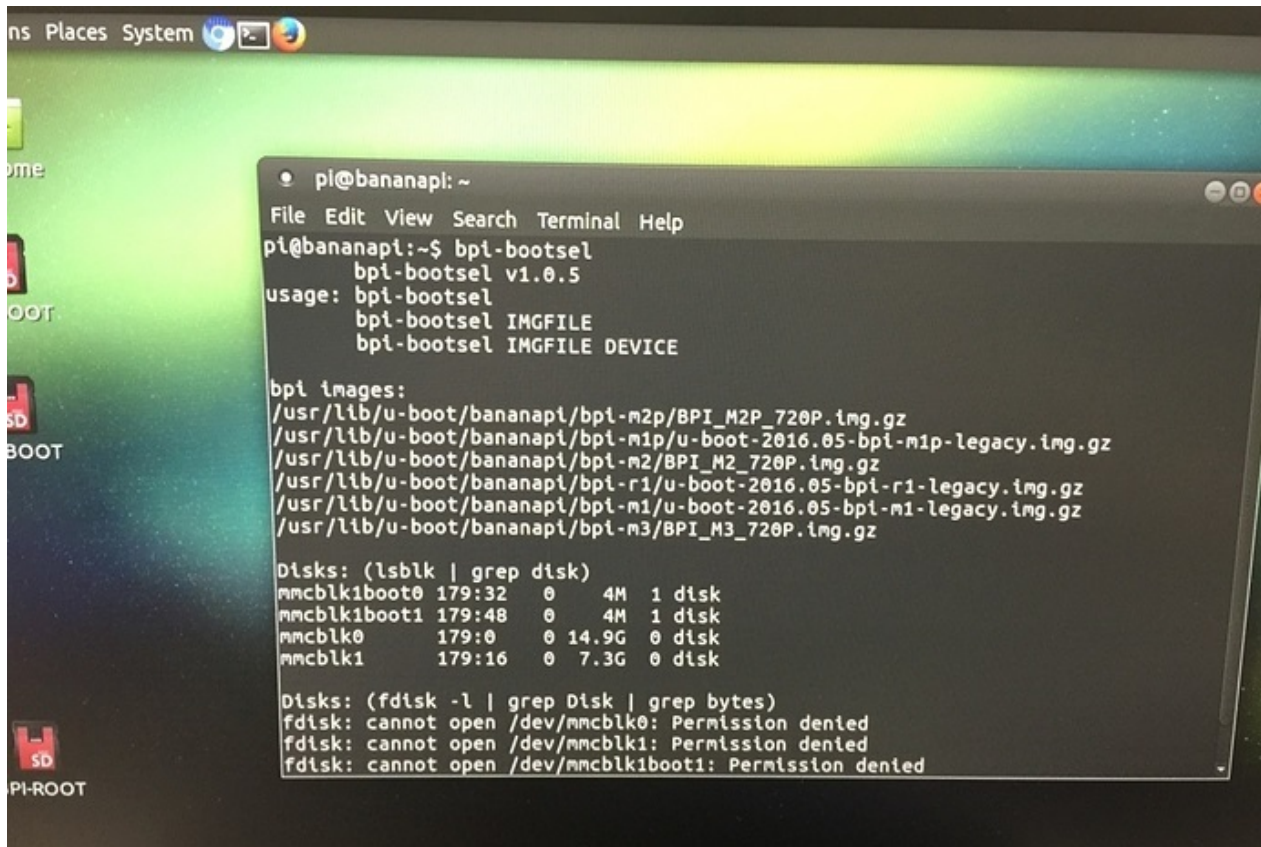

```
pi@bananapi: ~
File Edit View Search Terminal Help
pi@bananapi:~$ bpi-bootset
bpi-bootset v1.0.5
usage: bpi-bootset
       bpi-bootset IMGFILE
       bpi-bootset IMGFILE DEVICE

bpi images:
/usr/lib/u-boot/bananapi/bpi-m2p/BPI_M2P_720P.img.gz
/usr/lib/u-boot/bananapi/bpi-m1p/u-boot-2016.05-bpi-m1p-legacy.img.gz
/usr/lib/u-boot/bananapi/bpi-m2/BPI_M2_720P.img.gz
/usr/lib/u-boot/bananapi/bpi-r1/u-boot-2016.05-bpi-r1-legacy.img.gz
/usr/lib/u-boot/bananapi/bpi-m1/u-boot-2016.05-bpi-m1-legacy.img.gz
/usr/lib/u-boot/bananapi/bpi-m3/BPI_M3_720P.img.gz

Disks: (lsblk | grep disk)
mmcblk1boot0 179:32 0 4M 1 disk
mmcblk1boot1 179:48 0 4M 1 disk
mmcblk0 179:0 0 14.9G 0 disk
mmcblk1 179:16 0 7.3G 0 disk

Disks: (fdisk -l | grep Disk | grep bytes)
fdisk: cannot open /dev/mmcblk0: Permission denied
fdisk: cannot open /dev/mmcblk1: Permission denied
fdisk: cannot open /dev/mmcblk1boot1: Permission denied
```

1. Download BPI-Tools , please run the following command

```
wget https://github.com/BPI-SINOVOIP/BPI-files/raw/master/debs/bananapi-bpi-tools_1.0.3_armhf.deb
```

1. Set up development environment

2-1: On X86-PC (Ubuntu 12.04)

```
sudo echo "foreign-architecture armhf" >> /etc/dpkg/dpkg.cfg.d/multiarch
```

2-2 :On X86-PC (Ubuntu 14.04)

```
sudo dpkg --add-architecture armhf
```

2-3 :On BananaPI M3/M2Plus do nothing

2. Install BPI-Tools

```
sudo dpkg -i bananapi-bpi-tools*.deb
```

3. Create a folder of BPI-Tools

```
mkdir BPI-Tools cd BPI-Tools
```

4. Update BPI-Tools

```
sudo bpi-tools --upgrade
```

5. Use bpi-bootset command

6-1: M3 image is switchable to M2_Plus

```
sudo bpi-bootset /usr/lib/u-boot/bananapi/bpi-m2p/BPI_M2P_720P.img.gz
```

6-2 : M2_Plus image is switchable to M3image

```
sudo bpi-bootset /usr/lib/u-boot/bananapi/bpi-m3/BPI_M3_720P.img.gz
```

Video Demo

<https://www.youtube.com/watch?v=HdBNcrOKngM&feature=youtu.be>

bpi-get command

How to use bpi-get command (Download BPI Images)

```
bpi-get v1.0.3
usage: bpi-get
       bpi-get FILE
```

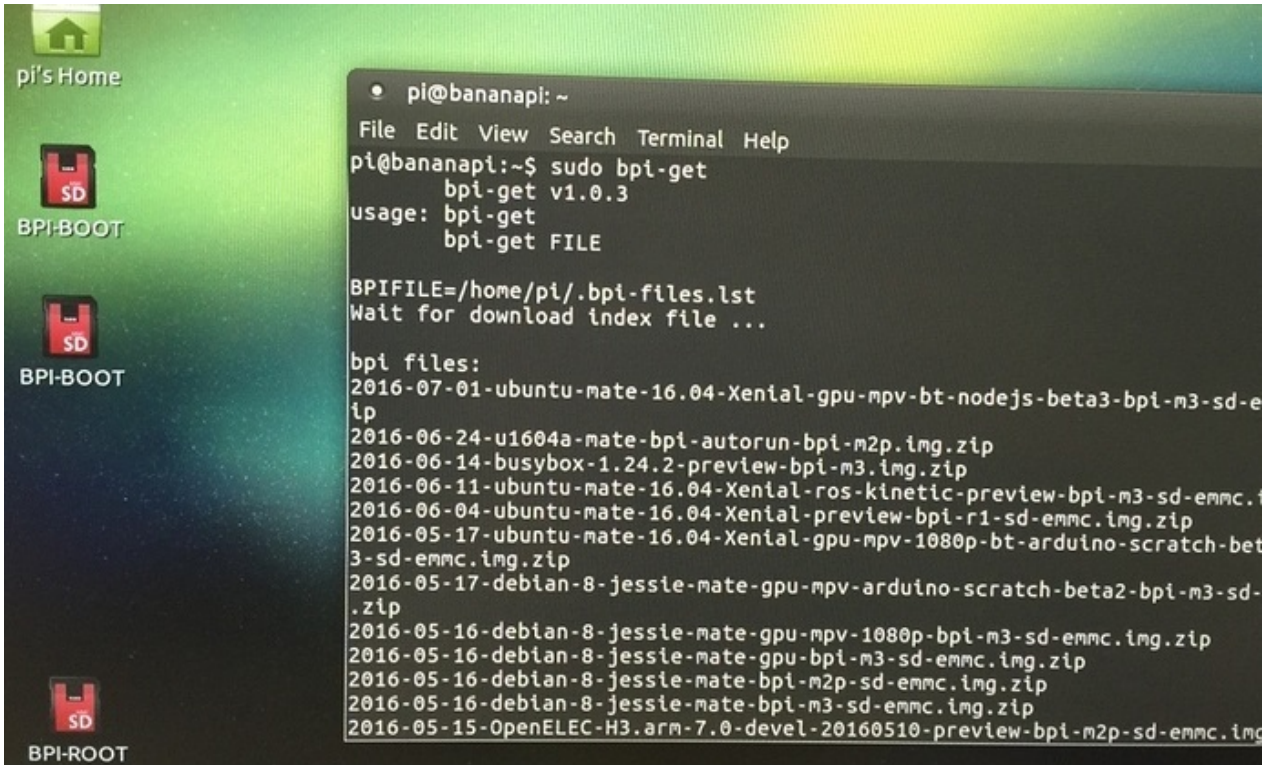

1. Download BPI-Tools , please run the following command

```
wget https://github.com/BPI-SINOVOIP/BPI-files/raw/master/debs/bananapi-bpi-tools\_1.0.3\_armhf.deb
```

1. Set up development environment

2-1: On X86-PC (Ubunut 12.04)

```
sudo echo "foreign-architecture armhf" >> /etc/dpkg/dpkg.cfg.d/multiarch
```

2-2 :On X86-PC (Ubunut 14.04)

```
sudo dpkg --add-architecture armhf
```

2-3 :On BananaPI M3/M2Plus do nothing

2. Install BPI-Tools

```
sudo dpkg -i bananapi-bpi-tools*.deb
```

3. Creat a folder of BPI-Tools

```
mkdir BPI-Tools cd BPI-Tools
```

4. Update BPI-Tools

```
sudo bpi-tools --upgrade
```

5. Use bpi-get command

6-1: Download BPI Images

```
sudo bpi-get 2016-07-01-ubuntu-mate-16.04-Xenial-gpu-mpv-bt-nodejs-beta3-bpi-m3-sd-emmc.img.zip
```

Video Demo

<https://www.youtube.com/watch?v=Bf4QfDnwKak&feature=youtu.be>

bpi-copy command

How to use bpi-copy command (Burning images to EMMC , Copying data from SD-Card/EMMC to be Images)

```
usage: bpi-copy
bpi-copy IMGFILE
bpi-copy IMGDIR
bpi-copy IMGFILE DEVICE
bpi-copy DEVICE IMGFILE
```

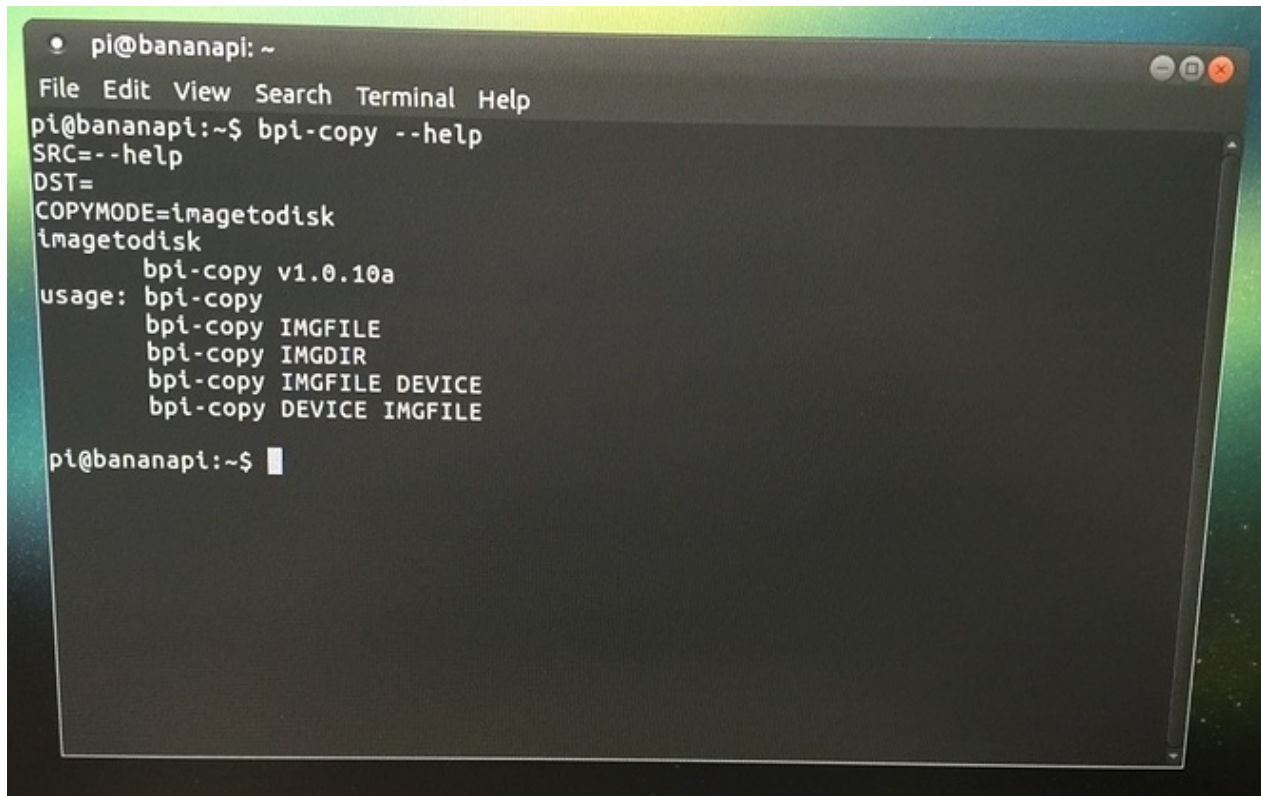

```
pi@bananapi: ~
File Edit View Search Terminal Help
pi@bananapi:~$ bpi-copy --help
SRC=--help
DST=
COPYMODE=imagetodisk
imagetodisk
bpi-copy v1.0.10a
usage: bpi-copy
bpi-copy IMGFILE
bpi-copy IMGDIR
bpi-copy IMGFILE DEVICE
bpi-copy DEVICE IMGFILE

pi@bananapi:~$
```

1. Download BPI-Tools , please run the following command

```
wget https://github.com/BPI-SINOVOIP/BPI-files/raw/master/debs/bananapi-bpi-tools\_1.0.3\_armhf.deb
```

1. Set up development environment

2-1: On X86-PC (Ubunut 12.04)

```
sudo echo "foreign-architecture armhf" >> /etc/dpkg/dpkg.cfg.d/multiarch
```

2-2 :On X86-PC (Ubunut 14.04)

```
sudo dpkg --add-architecture armhf
```

2-3 :**On BananaPI M3/M2Plus do nothing**

2. Install BPI-Tools

```
sudo dpkg -i bananapi-bpi-tools*.deb
```

3. Creat a folder of BPI-Tools

```
mkdir BPI-Tools cd BPI-Tools
```

4. Update BPI-Tools

```
sudo bpi-tools --upgrade
```

5. Use bpi-copy command

6-1: To burn into EMMC, please run the following command

```
sudo bpi-copy < images file>
```

6-2 :Copy data from SD-Card/EMMC to be Images

```
sudo bpi-copy < device path> < xxxxx.img.zip>
```

6-3 :To burn into certain device,please run the following command

```
sudo bpi-copy < xxxxx.img.zip> < device path>
```

Video Demo (To burn into EMMC)

<https://www.youtube.com/watch?v=Arn7HC2urt4>

Video Demo (Copy data from SD-Card/EMMC to be Images)

<https://www.youtube.com/watch?v=H1LjORwzO3E>

bpi-update command

How to : Use bpi-update command to update kernel image

Step1: Update bpi-tools

```
***  
$ git clone https://github.com/BPI-SINOVOIP/bpi-tools.git8  
$ cd bpi-tools  
$ sudo ./bpi-tools -u -U  
***
```

Step 2: Check bpi-tools version

```
***  
$ bpi-tools -v  
***
```

Step 3: Use bpi-update to update kernel

```
***  
$ mkdir update_file  
$ cd update_file  
***
```

BPI-M2U

```
***  
$ sudo bpi-update -c bpi-m2u.conf  
***
```

BPI-M2P

```
***  
$ sudo bpi-update -c bpi-m2p.conf  
***
```

BPI-M3

```
***  
$ sudo bpi-update -c bpi-m3.conf  
***
```

Openelec for BPI-M2+

test image download for BPI-M2+:



<http://down.nu/temp/OpenELEC-H3.arm-7.0-devel-20160608000933-r22848-g785d33d-bpim2p.img.gz>

sha1sum: 8543c7f5100e2e4c9cd8b03d7ce762ef90df4071

newest image download link:

<http://down.nu/images/2016-10-26/OpenELEC-H3.arm-7.0-devel-20161026220508-r23113-g64b34b3-bpim2p.img.gz>



source code on github

<https://github.com/jernejsk/OpenELEC-OPi2/>

build instructions:

```
git clone -b openelec-7.0 --depth 1 https://github.com/jernejsk/OpenELEC-OPi2 PROJECT=H3 ARCH=arm SYSTEM=bpim2p make image
```

What works:

- mostly all supported codecs
- wifi & bluetooth
- IR can be set to basically any remote
- emmc installation via emmc_install.sh
- HW rendering & deinterlacing
- automatic updates (when I prepare new build, you can update with just a click)
- included "official" and "unofficial" repositories (built by me, so please don't report bugs to upstream OpenELEC)

What doesn't:

- suspend & resume - crash due to a bug in ethernet driver
- no vsync
- CEC is work in progress

The screenshot shows a GitHub repository page for 'jernejsk / OpenELEC-OPi2'. The repository is forked from 'OpenELEC/OpenELEC.tv'. It has 14 watchers, 30 stars, and 966 forks. The current branch is 'openelec-7.0'. The commit history shows several recent commits, including one by 'jernejsk' titled 'u-boot: Add new target for opiplus2e' 2 days ago. The page also includes navigation links for 'Code', 'Issues', 'Pull requests', 'Pulse', and 'Graphs'. At the bottom, there are links for 'Create new file', 'Upload files', 'Find file', and 'History'. The footer contains copyright information for GitHub, Inc. and links for 'Status', 'API', 'Training', 'Shop', 'Blog', and 'About'.

Video demo on youtube:

https://www.youtube.com/watch?v=vPIbE5znU_8

Lakka TV

The newly supported boards are:

Banana Pi M2+ with H3 chip Banana Pi M3 with A83T chip

for BPI-M1 and BPI-M1+ use A20 chip design ,also can find some support for A20.

As you can see, H3 is used in a lot of boards. Each of them have different specs. Some of them are available at a very cheap price.

The original OpenELEC and LibreELEC port has been done by @jernejsk and we backported it to Lakka.

The images can be downloaded from there:

<http://mirror.lakka.tv/nightly/>

@Ntemis took care of testing the image on some of these boards and Lakka and RetroArch are working well on them.

If you are new to Lakka and want to test one of the images, just adapt the installation instruction that you can find on our website for any other ARM board.

As I don't own any of these boards myself, I can't check them for regressions and support them officially for now. But I will as soon as some contributors send me one or two.

We need more owners of any of these boards on our IRC chan to check if all the images are really working well. Remember that this is mainly untested work when you report bugs.

more please visit lakka TV official website:

<http://www.lakka.tv/>

Dietpi for BPI-M2+

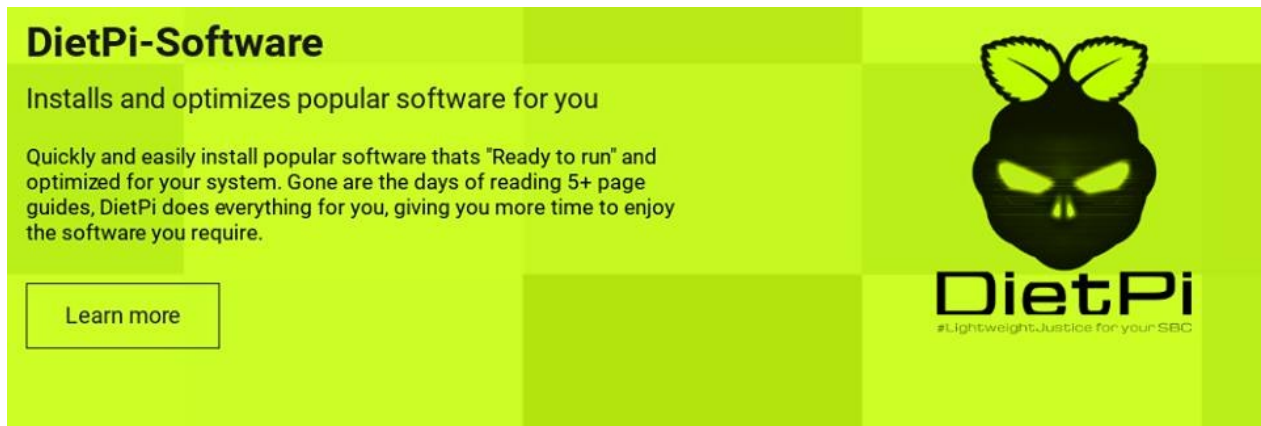
A promotional banner for DietPi software. The background is a light blue grid. On the left, the text reads: "DietPi-Software", "Installs and optimizes popular software for you", and "Quickly and easily install popular software that's 'Ready to run' and optimized for your system. Gone are the days of reading 5+ page guides, DietPi does everything for you, giving you more time to enjoy the software you require." Below this is a "Learn more" button. On the right is the DietPi logo, which is a stylized black skull with glowing yellow eyes and two green leaves on top. Below the logo, the text "DietPi" is written in a bold, sans-serif font, with the tagline "#Lightweight.Justice for your SBC" underneath.

DietPi-Software

Installs and optimizes popular software for you

Quickly and easily install popular software that's "Ready to run" and optimized for your system. Gone are the days of reading 5+ page guides, DietPi does everything for you, giving you more time to enjoy the software you require.

[Learn more](#)

DietPi
#Lightweight.Justice for your SBC

Dietpi.com have official support BPI-M2+

what is Dietpi

At its core, DietPi is the goto image for your needs. Whether you are after a maximum performance minimal image, or, you want an optimized BitTorrent server with Owncloud running Kodi. DietPi can do it all.

All the DietPi images come pre-optimized with features like automatic filesystem expansion | "DietPi-Ramlog" (/var/log to ram) | Minimal CPU/Memory footprint and low process count to ensure you get the max performance from your device.

image download and more information:

<http://dietpi.com/>

more DietPi official documents:

- DietPi Software: <http://dietpi.com/phpbb/viewtopic.php?f=8&t=5#p5>
- DietPi Config: <http://dietpi.com/phpbb/viewtopic.php?f=8&t=63&p=218#p218>
- DietPi Backup: <http://dietpi.com/phpbb/viewtopic.php?f=8&t=5&start=30#p255>
- DietPi Sync: <http://dietpi.com/phpbb/viewtopic.php?f=8&t=5&start=30#p256>
- DietPi ProcessTool: <http://dietpi.com/phpbb/viewtopic.php?f=8&t=5&start=30#p279>
- LogginSystem Choices: <http://dietpi.com/phpbb/viewtopic.php?f=8&t=5&start=20#p68>
- FileServer Choices: <http://dietpi.com/phpbb/viewtopic.php?f=8&t=15#p19>

RetrOrangePi

RetrOrangePi is a gaming and media center distribution for the Orange Pi and banana pi, based on Armbian. It includes RetroArch and Kodi. It is the merge of AlerinoReis_Ubuntu_Retropie_and_Emulation_Station(ES) and Stevie_Whyte_Retropie_for_OPi with many bug fixes and improvements. RetrOrangePi is developed and maintained by Alerino Reis and Stevie Whyte with collaboration of Wang Matt.

The screenshot shows the website www.retrorangepi.org. The page has a dark theme with a navigation menu containing 'General', 'Platforms', 'Ports', and 'Boards'. The 'GENERAL' section is active and displays a list of features:

- Full Armbian 5.23 Jessie Desktop version with kernel 3.4.113
- OpenELEC Kodi Jarvis 16.1 (separated partition)
- Debian Kodi 17.0 (Krypton beta6)
- RetroPie-Setup version 4.1
- EmulationStation UI
- Retroarch with XMB menu driver (Lakka)
- Splashscreen support (video / image with audio)
- Wifi support
- GPIO support (included installer)
- Background music (users can add)
- Full input support (PS3, Xbox, generic gamepad, keyboard, mice etc)
- Plug n' Play - USB roms autoload (reads from /media/usb0) - EXPERIMENTAL
- Dummy roms feature (most common platforms already shown)
- New splash video on 1st boot by Rafael Spirax
- New default splashscreen (from Libretro)
- New custom ES splashscreen by Francois Lebel @MagicFranky
- OpenELEC ROPI addon already installed
- Better looking video with bilinear filtering (smoothness) or scanlines by default
- Most retroarch cores updated (FBA, PCSX etc)

can support allwinner H3 chip and allwinner A20 chip.

official website and image download :

<http://www.retrorangepi.org/>

WIKI documents:

<http://orange314.com/RetrOrangePi>

Github:

<https://github.com/Harryzimm>

FreeBSD on Allwinner (sunxi) systems for banana pi

Banana pi as the official partner of Allwinner , must banana pi product use Allwinner chip design . such as A20/A31S/H3/H2+/A64/A83T , and FreeBSD have support many Allwinner . so easy to use on banana pi board.

Supported SoCs

FreeBSD supports the following Allwinner SoCs:

- Allwinner A10 (sun4i), a single core Cortex-A8
- Allwinner A13/R8 (sun5i), a single core Cortex-A8
- Allwinner A20 (sun7i), a dual-core Cortex-A7
- Allwinner A31 and A31s (sun6i), a quad-core Cortex-A7
- Allwinner A64 (sun50i), a quad-core Cortex-A53
- Allwinner A83T (sun8i), an octa-core Cortex-A7
- Allwinner H3 (sun8i), a quad-core Cortex-A7

Supported boards

These SoCs are showing up in a growing number of development boards and other devices. FreeBSD has support for some of these boards, including (but not limited to) the following:

A10 Supported Boards

- [Cubieboard](#)
- [A10-Olinuxino-Lime](#)

A20 Supported Boards

- [CubieBoard 2](#)
- [Banana Pi](#)
- [Olimex A20 SOM](#)
- [PCDuino3](#)

A31/A31S Supported Boards

- [BPI-M1/BPI-M1+/BPI-R1](#)
- [BPI-M2](#)
- [BPI-M2+/BPI-M2+ EDU](#)

Allwinner A20 (sun7i), a dual-core Cortex-A7 **BPI-M1/BPI-M1+/BPI-R1**

Allwinner A31 and A31s (sun6i), a quad-core Cortex-A7 **BPI-M2**

Allwinner A64 (sun50i), a quad-core Cortex-A53 **BPI-M64** Allwinner A83T (sun8i), an octa-core Cortex-A7 **BPI-M3**

Allwinner H3 (sun8i), a quad-core Cortex-A7 ****BPI-M2+/BPI-M2+ EDU/****

<https://wiki.freebsd.org/FreeBSD/arm/Allwinner>

Porting NetBSD to Allwinner H3 SoCs

Banana pi BPI BPI-M2+ use Awinner H3 chip design . so it also can run NetBSD on it

http://blog.netbsd.org/tnf/entry/porting_netbsd_to_allwinner_h3

<http://cvsweb.netbsd.org/bsdweb.cgi/src/sys/arch/evbarm/sunxi/>

BPI-M2+/BPI-M2 Zero source code on github

All newest source code have update on this github site.

BPI-M2+ code on github

<https://github.com/BPI-SINOVOIP/BPI-M2P-bsp>

https://github.com/BPI-SINOVOIP/BPI-M2P-bsp

This repository Search Pull requests Issues Gist

BPI-SINOVOIP / BPI-M2P-bsp Unwatch

Code Issues 0 Pull requests 0 Wiki Pulse Graphs Settings

Supports BananaPi BPI -M2+ (Kernel3.4) — Edit

2 commits 1 branch 0 releases

Branch: master New pull request New file Upload files Find file HTTPS https://github.com/BPI-

BPI-SINOVOIP first commit

allwinner-tools	first commit
linux-sunxi	first commit
rootfs/linux	first commit
scripts	first commit
sunxi-pack	first commit
u-boot-sunxi	first commit

BPI-M2 Zero code on github

安全 https://github.com/BPI-SINOVOIP/BPI-M2Z-bsp

网址导航 百度一下 爱淘宝 聚划算 JD 京东商城 头条视频 影视大全 汽车之家 热门游戏 BPI-R2 boot with ke SinoVoip Co., Limited 爱淘宝

This repository Search Pull requests Issues Marketplace Explore

BPI-SINOVOIP / BPI-M2Z-bsp Unwatch 1 Star 0 Fork 0

Code Issues 0 Pull requests 0 Projects 0 Wiki Insights Settings

Supports Banana Pi BPI-M2 Zero (Kernel3.4) Edit

Add topics

22 commits 1 branch 0 releases 2 contributors

Branch: master New pull request Create new file Upload files Find file Clone or download

BPI-SINOVOIP u-boot-sunxi: skip check for new BPI-M2Z card cd pin reverse(insert=1... Latest commit 7970567 on Sep 19

allwinner-tools/gcc-linaro-6.3.1-201...	init: u-boot-2017-07-rc2 & kernel 3.4.113	4 months ago
linux-sunxi	enable 40pin i2c and spi	3 months ago
scripts	init: u-boot-2017-07-rc2 & kernel 3.4.113	4 months ago
sunxi-pack	enable 40pin i2c and spi	3 months ago

<https://github.com/BPI-SINOVOIP/BPI-M2Z-bsp>

BPI-M2+ fix rootmydevice issue for Security Alert

BPI-M2P+: fix rootmydevice issue

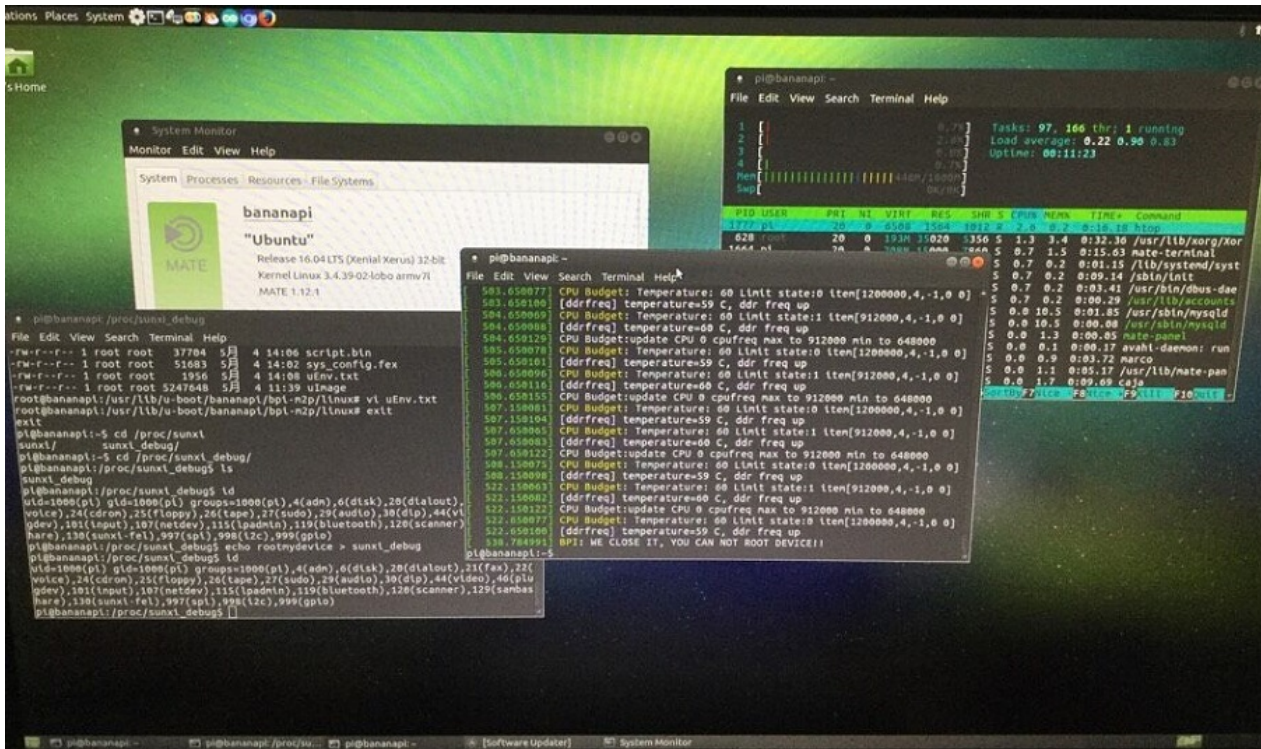

STEP 1. download update file & install STEP 2. update boot files

=====STEP 1:=====

on ubuntu / raspbian / debian :

download file: linux-bananapi-bpi-m2p-kernel3_1.2.5_armhf.deb

github: https://github.com/BPI-SINOVOIP/BPI-files/raw/master/debs/linux-bananapi-bpi-m2p-kernel3_1.2.5_armhf.deb

google drive: https://drive.google.com/file/d/0B_YnvHgh2rwjHJYOVA3VHh0cm8/view?usp=sharing

MD5: a85b36bae432516bfeee4bdc930073b9

```
# sudo dpkg -i linux-bananapi-bpi-m2p-kerne13_1.2.5_armhf.deb
```

on other system :

download file: 3.4.39-BPI-M2P-Kernel.tgz

google drive: https://drive.google.com/file/d/0B_YnvHgh2rweVW2YWQySC1EMjQ/view?usp=sharing

MD5: 827b9e0e0dc9b73dde816ff2bc86ae32

```
# sudo tar xvf 3.4.39-BPI-M2P-Kerne1.tgz -C /
```

=====STEP 2:=====

```
# sudo su
# ls -l /usr/lib/u-boot/bananapi/bpi-m2p/linux
total 5224
-rw-r--r-- 1 root root 37704 5月 4 14:06 script.bin
-rw-r--r-- 1 root root 51683 5月 4 14:02 sys_config.fex
-rw-r--r-- 1 root root 1956 5月 6 08:43 uEnv.txt
-rw-r--r-- 1 root root 5247648 5月 4 11:39 uImage

# mount /dev/mmcblk0p1 /boot
# cp -a /usr/lib/u-boot/bananapi/bpi-m2p/linux/* /boot/bananapi/bpi-m2p/linux
# bpi-bootset /usr/lib/u-boot/bananapi/bpi-m2p/BPI_M2P_720P.img.gz
# reboot
```

How to setup docker env. to build github source code

how to setup docker env. to build banana pi github source code

step 1: install docker

<https://docs.docker.com/engine/installation/linux/ubuntu/linux/>

step 2: docker run

<https://hub.docker.com/r/sinovoip/bpi-build/>

```
$ docker run -d -p 2222:22 -v /media:/media sinovoip/bpi-build:ubuntu12.04
```

on your host

```
$ ssh -p 2222 root@127.0.0.1 //default passwd is root
```

or (with --privileged can use /dev/loop for create img)

```
$ docker run -d -p 3333:22 --privileged -v /media:/media sinovoip/bpi-build:ubuntu12.04
```

```
$ ssh -p 3333 root@127.0.0.1 //default passwd is root
```

step 3: git clone

```
# cd /media/XXX/your-source  
# git clone https://github.com/BPI-SINOVOIP/BPI-M3-bsp.git
```

step 4: build

```
# ./build.sh
```

how to create your own env. to build the code

step 1: git clone <https://github.com/BPI-SINOVOIP/bpi-build.git>

step 2: vi Dockerfile

step 3. vi build.sh

step 4: ./build.sh

why use docker env. to build banana pi source code

1. allwinner tools needs ubuntu12.04 with ia32-libs ...
2. user maybe use ubuntu 12.04 or 14.04 and newer like 16.04, the docker env. the same, even other linux like fedora opensuse archlinux, or other os like macos , windows ...
3. build BPI-Mx-bsp env. than mainline kernel & uboot or android 4.X or android 5.X / 6.X not the same.

How to compile BPI-M2+ BSP and boot image

1, download Linux image Ubuntu-12.04 64bit system :

download link : <http://mirrors.163.com/ubuntu-releases/12.04/ubuntu-12.04.5-desktop-amd64.iso>

just use this version , do not need upgrade to newest version.

2 , install Linux system on virtual machine :

note : you need Modify the network card to bridge mode (copy network status) when you install linux system.

3,install tooling on linux system :

```
sudo apt-get update && apt-get install -y \  
apt-utils\  
openssh-server\  
build-essential\  
gcc-arm-linux-gnueabihf\  
g++-arm-linux-gnueabihf\  
gcc-arm-linux-gnueabi\  
g++-arm-linux-gnueabi\  
unzip\  
sudo\  
Git\  
mercurial\  
vim\  
bc\  
u-boot-tools\  
device-tree-compiler\  
ia32-libs\  
pkg-config\  
libusb-1.0-0-dev\  
Python-software-properties\  
software-properties-common\  
libncurses5-dev\  
busybox
```

4,download BPI-M2+ BSP code :

install git tooling

```
sudo apt-get install git-core
```

download source code for BPI-M2+

```
sudo git clone https://github.com/BPI-SINOVOIP/BPI-M2P-bsp.git  
sudo git clone https://github.com/BPI-SINOVOIP/bpi-tools.git
```

5,compile BPI-M2+ bsp code :

```
sudo ./build.sh
```

please choose option 1 , compile all source code.

Compile process takes longer, please wait for complete

6,Made SD card :

6.1, use GParted tooling to format SD card

```
install : sudo apt-get install -y gparted
```

In the graphical interface operation, formatted into : 100M reserve + 50M(Fat32 format) + 500M(Ext4 format)

Note: the formatting Fat32 and corruption partition size can be adjusted, can adjust the Fat32 is 200 m, corruption all USES the remaining space

6,2,mount SD card , Fat32 Partition mounted as usb1 , Ext4 Partition mounted asusb2.

```
sudo mount /dev/sdb1 /mnt/usb1
sudo mount /dev/sdb2 /mnt/usb2
```

6,3,made busybox root file system:

download link :

https://github.com/BPI-SINOVOIP/BPI-files/blob/master/rootfs/busybox-1.24.2_bash-root.tgz

Extract the downloaded file to Ext4 partition

```
sudo mount /dev/sdb2 /mnt/usb2
sudo tar xvf busybox-1.24.2_bash-root.tgz -C /mnt/usb2
```

6,4,unzip SD card .tgz file to different partitions

```
cd BPI_M2P_bsp/SD
sudo tar xvf ./BPI-B00T-bpi-m2p.tgz -C /mnt/usb1
sudo tar xvf ./B00TLOADER-bpi-m2p.tgz -C /mnt/usb2
sudo tar xvf ./3.4.39-BPI-M2P-Kernel.tgz -C /mnt/usb2
```

6,5, Use bpi-boot tool production start (The first 100M)

```
sudo ../../bpi-tools/bpi-bootse1./100MB/BPI_M2P_720P.img.gz/dev/sdb
```

6,6 Production process takes long time, please wait until it finish.

7, when finish :

BPI-M2+ board insert SD card and power on.

8,Cloning system, operating under BPI-M2+ board :

Insert SD card through the card reader into the usb port of BPI-M2+ board, called equipment: /dev/sda

Note: dd 700M here, already contains the system part of a total of 650M, 100M partition (tenure) + (Fat32) 50M+ 500M (Ext4) = 650M

8.1 Direct cloning system:

```
dd if=/dev/mmcblk0 of=/dev/sda bs=10M count=70
```

8.1 Cloning to image file:

```
mount /dev/sda0 /mnt/sd
dd if=/dev/mmcblk0of=/mnt/sd/m2p_os.img bs=10M count=70
```

8.2 Cloning to eMMC flash:

```
dd if=/dev/mmcblk0 of=/dev/mmcblk1 bs=10M count=70
```

9,use img file made boot SD card:

9.1 , windows system use SDFormatter format SD card 9.2 , windows system use Win32DiskImager burn image file to SD card

BPI-M2+ Reference documents

H3 Linux-sunxi wiki

about allwinner H3 chip,please reference this link:

<http://linux-sunxi.org/H3>

all about allwinner chip :

https://en.wikipedia.org/wiki/Allwinner_Technology

H3 Manual build howto

banana pi BPI-M2+ use allwinner H3 chip onboard.

This page describes the process to combine Allwinners binary boot0, an SDK U-Boot, an SDK linux kernel and other bits together to create a useful SD-card from scratch, the basis for further hacking.

This page is only suited for H3 based devices, please look under See also for other manual build howtos.

We of course do not build a whole distribution, we only build U-Boot, the kernel and a handful of tools, and then use an existing rootfs to get a useful system. Depending on the rootfs size, you might want to use a 2GB or larger SD Card. SD-card partitioning and formatting will be taken care of later.

Link:

http://linux-sunxi.org/H3_Manual_build_howto

BPI-M2+ linux-sunxi wiki

http://linux-sunxi.org/Sinovoip_Banana_Pi_M2%2B

Banana pi wikipedia wiki

all banana pi development board wikipedia wiki

https://en.wikipedia.org/wiki/Banana_Pi

BPI-M2+ online video

- Banana pi M2+ android

https://www.youtube.com/watch?time_continue=8&v=Bxbj0zA_0vl

- OpenElec on banana pi M2+ 4K and arcade test

<https://www.youtube.com/watch?v=FoH4TaepMMY>

- banana pi BPI-M2+ (BPI-M2 plus) test IR remote control

https://www.youtube.com/watch?v=HhW_G85Byio

- banana pi BPI-M2+ decode 1080P test

<https://www.youtube.com/watch?v=sZAbhTNWB94>

- Armbian Banana pi M2+ demo

<https://www.youtube.com/watch?v=uTJp78d1TFU>

- Banana PI M2+ gpu performance (Armbian)

<https://www.youtube.com/watch?v=q2vtjxJ4N30>

- Openelec Kodi 16.0 (xbmc) on the Banana Pi BPI M2+

https://www.youtube.com/watch?v=vPIbE5znU_8

- Banana pi BPI-M2+ support 4K TV

<https://www.youtube.com/watch?v=hteLkEo2id0>

Allwinner GPL_Violations

Allwinner has repeatedly violated the GPL (and by proxy so have most hardware manufacturers and resellers using or selling products based on Allwinner chipsets). Either by not providing (Linux/Android) kernel or u-boot source at all, or by delivering trees with pre-built binaries and no matching source code. They even blatantly use LGPL licensed code in their userspace libraries for media decoding.

Over time, Allwinner has only increased the binary blobs present in their kernel trees, showing clearly that - even though Allwinner in the meantime joined Linaro - it is not progressing. Quite the opposite actually, and one has to worry about what value Linaro membership really has if a member is allowed to behave like this. Allwinner also joined the Linux Foundation as of June 2015, while compliance issues clearly remain.

http://linux-sunxi.org/GPL_Violations

Linux mainlining effort

The purpose of this page is to try and define sub-goals and milestones for the mainlining effort, containing goals and sub-goals with milestones for adding Allwinner support in the upstream mainline Linux Kernel.

It is very important to note that this is intended as a rough set of minimal goals - it is not meant to collide with the huge effort of rewriting major drivers!

more ,please see link:

http://linux-sunxi.org/Linux_mainlining_effort

Allwinner chip documents

allwinner chip online datasheet and documents:

← → ↻ dl.linux-sunxi.org

Index of /

File Name ↓	File Size ↓	Date ↓
Parent directory/	-	-
A10/	-	27-Sep-2014 11:51
A10s/	-	27-Sep-2014 11:51
A13/	-	27-Sep-2014 11:51
A20/	-	13-Jan-2015 11:26
A23/	-	21-Aug-2014 07:56
A31/	-	27-Sep-2014 11:51
A31s/	-	27-Sep-2014 11:51
A33/	-	27-Jun-2015 14:11
A64/	-	16-Dec-2015 00:02
A80/	-	24-Sep-2014 08:18
A83T/	-	08-Jan-2015 21:24
AXP/	-	08-Jan-2015 21:28
F1C100/	-	12-Aug-2014 12:34
F20/	-	28-Mar-2014 15:41
H3/	-	02-Apr-2015 08:29
SDK/	-	27-Aug-2014 14:04
allwinner/	-	04-Mar-2013 14:49
chips/	-	19-May-2013 23:37
mali/	-	16-Oct-2012 21:22
nightly/	-	15-Nov-2013 18:58
rtlwifi/	-	25-Sep-2012 19:05
touchscreen/	-	22-Mar-2015 16:13
users/	-	19-Sep-2014 11:45
robots.txt	84	26-Aug-2014 10:22

<http://dl.linux-sunxi.org/>

Allwinner H3 chip datasheet on line

https://linux-sunxi.org/images/4/4b/Allwinner_H3_Datasheet_V1.2.pdf

BPI-M2+ quality guarantee

All the products Banana pi release go through strictly controlled process from developing,testing,manufacturing to certification.

We put quality first, users can mass produce their products using our boards directly, we've been dedicating to providing the most cost performance products.

BPI-M2+ BT 4.0 test report

Anritsu BlueTest2 Test Report

Test Set Serial Number: 6K00006250

EUT Bluetooth Address: 983B16000000

Date: 2016/3/25 Time: 11:13:20

Overall Result: PASS

TRM/CA/01/C (Output Power)

Packet Length Tested: DH5

	<u>Low</u>	<u>Med</u>	<u>High</u>	<u>Limits</u>
Hopping ON				
Average Power	10.36 dBm	9.71 dBm	8.80 dBm	
Max Power	10.37 dBm	9.74 dBm	8.81 dBm	< 20.00 dBm
Min Power	10.36 dBm	9.70 dBm	8.80 dBm	> -6.00 dBm
Peak Power	10.78 dBm	10.08 dBm	9.19 dBm	< 23.00 dBm
Total Packets Failed	0	0	0	
Total Packets Tested	10	10	10	
Result	Pass	Pass	Pass	

TRM/CA/03/C (Power Control)

Packet Length Tested: DH1

	<u>Low</u>	<u>Med</u>	<u>High</u>	<u>Limits</u>
Hopping OFF				
Max Power	10.40 dB	9.70 dB	8.70 dB	
Min Power	-20.90 dB	-22.00 dB	-22.70 dB	
Max Power Step	5.40 dB	5.70 dB	5.50 dB	<= 8.00 dB
Min Power Step	4.00 dB	3.70 dB	3.40 dB	>= 2.00 dB
Total Packets Failed	0	0	0	
Total Packets Tested	14	14	14	
Result	Pass	Pass	Pass	

TRM/CA/08/C (Initial Carrier)

Packet Length Tested: DH1

	<u>Low</u>	<u>Med</u>	<u>High</u>	<u>Limits</u>
Hopping ON				
Average Offset	21.9 kHz	18.0 kHz	19.1 kHz	
Max Offset	26.3 kHz	20.9 kHz	22.6 kHz	<= 75 kHz
Min Offset	19.0 kHz	15.8 kHz	14.4 kHz	<= 75 kHz
Total Packets Failed	0	0	0	
Total Packets Tested	10	10	10	
Result	Pass	Pass	Pass	

TRM/CA/09/C (Carrier Drift)



Hopping On - Low Channel

	<u>DH1</u>	<u>DH3</u>	<u>DH5</u>	<u>Limits</u>
Drift Rate / 50µs	-3.73 kHz	-5.45 kHz	-5.88 kHz	+/- 20 kHz
Max Drift	-7 kHz	8 kHz	8 kHz	DH1: +/- 25kHz
Average Drift	0 kHz	-1 kHz	2 kHz	DH3: +/- 40kHz
Total Packets Failed	0	0	0	DH5: +/- 40kHz
Total Packets Tested	10	10	10	
Overall Result	Pass	Pass	Pass	

Hopping On - Med Channel

	<u>DH1</u>	<u>DH3</u>	<u>DH5</u>	<u>Limits</u>
Drift Rate / 50µs	4.73 kHz	-6.42 kHz	-5.47 kHz	+/- 20 kHz
Max Drift	11 kHz	8 kHz	7 kHz	DH1: +/- 25kHz
Average Drift	2 kHz	-1 kHz	0 kHz	DH3: +/- 40kHz
Total Packets Failed	0	0	0	DH5: +/- 40kHz
Total Packets Tested	10	10	10	
Overall Result	Pass	Pass	Pass	

Hopping On - High Channel

	<u>DH1</u>	<u>DH3</u>	<u>DH5</u>	<u>Limits</u>
Drift Rate / 50µs	-6.00 kHz	-6.41 kHz	-5.82 kHz	+/- 20 kHz
Max Drift	7 kHz	-9 kHz	10 kHz	DH1: +/- 25kHz
Average Drift	3 kHz	-1 kHz	0 kHz	DH3: +/- 40kHz
Total Packets Failed	0	0	0	DH5: +/- 40kHz
Total Packets Tested	10	10	10	
Overall Result	Pass	Pass	Pass	

TRM/CA/07/C (Modulation Characteristic)

Packet Length Tested: DH5

Hopping OFF	Low	Med	High	Limits
'F1avg'	158.9 kHz	158.8 kHz	157.2 kHz	140kHz < F1 < 175kHz
'F1max'	165.5 kHz	166.1 kHz	165.5 kHz	
F1 Packets Failed	0	0	0	
'F2avg'	161.2 kHz	161.7 kHz	162.0 kHz	
'F2max'	146.3 kHz	148.4 kHz	146.6 kHz	>= 115 kHz
'F2max' Pass Rate	100.00%	100.00%	100.00%	
F1/F2 Ratio	1.01	1.01	1.03	>= 0.8
Total Packets Tested	20	20	20	
Result	Pass	Pass	Pass	

RCV/CA/01/C (Single Sensitivity)

Power Level: -86 dBm, Dirty Tx Status: ON

Hopping ON	Any	Limits
Overall BER	0.01%	<= 0.1%
Overall FER	0.86%	<= 100%
Packets Sent	7408	
Total Packets Tested	7394	
Bit Errors	115	
Total Packets Failed	64	
CRC Errors	48	
Length Errors	2	
Lost Packets	14	
Result	Pass	

Hopping OFF	Low	Med	High	Limits
Overall BER	0.00%	0.00%	0.00%	<= 0.1%
Overall FER	0.16%	0.04%	0.15%	<= 100%
Packets Sent	7408	7408	7408	
Total Packets Tested	7397	7408	7398	
Bit Errors	1	2	1	
Total Packets Failed	12	3	11	
CRC Errors	1	3	1	
Length Errors	0	0	0	
Lost Packets	11	0	10	
Result	Pass	Pass	Pass	

RCV/CA/02/C (Multi Slot Sensitivity)

Power Level: -86 dBm, Dirty Tx Status: ON, Packet Length Tested: DH5

Hopping ON	Any	Limits
Overall BER	0.00%	<= 0.1%
Overall FER	1.02%	<= 100%
Packets Sent	590	
Total Packets Tested	589	
Bit Errors	45	
Total Packets Failed	6	
CRC Errors	5	
Length Errors	0	
Lost Packets	1	
Result	Pass	

Hopping OFF	Low	Med	High	Limits
Overall BER	0.00%	0.00%	0.00%	<= 0.1%
Overall FER	0.00%	0.34%	0.17%	<= 100%
Packets Sent	590	590	590	
Total Packets Tested	590	590	590	
Bit Errors	0	2	1	
Total Packets Failed	0	2	1	
CRC Errors	0	2	1	
Length Errors	0	0	0	
Lost Packets	0	0	0	
Result	Pass	Pass	Pass	

RCV/CA/06/C (Max Input Level)

Power Level: -20dBm

Hopping OFF	Low	Med	High	Limits
Overall BER	0.00%	0.00%	0.00%	<= 0.1%
Overall FER	0.00%	0.00%	0.03%	<= 100%
Packets Sent	7408	7408	7408	
Total Packets Tested	7408	7408	7406	
Bit Errors	0	0	0	
Total Packets Failed	0	0	2	
CRC Errors	0	0	0	
Length Errors	0	0	0	
Lost Packets	0	0	2	
Result	Pass	Pass	Pass	

TRM/CA/10/C (EDR Relative Transmit Power)

2Mbps Packet Length: 2-DH5, 3Mbps Packet Length: 3-DH5

2Mbps/sec	EUT Max			Limits
Hopping OFF	Low	Med	High	
Max difference	0.10 dB	0.05 dB	-0.04 dB	Max: 1.00 dB
Min difference	0.06 dB	0.02 dB	-0.01 dB	Min: -4.00 dB
Avg difference	0.08 dB	0.03 dB	-0.03 dB	
GFSK Max	8.15 dBm	7.25 dBm	6.40 dBm	
GFSK Min	8.12 dBm	7.23 dBm	6.39 dBm	
GFSK Avg	8.13 dBm	7.24 dBm	6.40 dBm	
GFSK Pk	8.38 dBm	7.45 dBm	6.63 dBm	
DPSK Max	8.22 dBm	7.28 dBm	6.38 dBm	
DPSK Min	8.18 dBm	7.25 dBm	6.35 dBm	
DPSK Avg	8.21 dBm	7.27 dBm	6.37 dBm	
DPSK Pk	10.64 dBm	9.62 dBm	8.57 dBm	
Result	Pass	Pass	Pass	

2Mbps/sec	EUT Min			Limits
Hopping OFF	Low	Med	High	
Max difference	0.30 dB	0.29 dB	0.30 dB	Max: 1.00 dB
Min difference	0.27 dB	0.26 dB	0.26 dB	Min: -4.00 dB
Avg difference	0.29 dB	0.28 dB	0.29 dB	
GFSK Max	-25.38 dBm	-27.35 dBm	-28.30 dBm	
GFSK Min	-25.39 dBm	-27.36 dBm	-28.33 dBm	
GFSK Avg	-25.38 dBm	-27.35 dBm	-28.31 dBm	
GFSK Pk	-25.18 dBm	-27.17 dBm	-28.08 dBm	
DPSK Max	-25.08 dBm	-27.08 dBm	-28.02 dBm	
DPSK Min	-25.11 dBm	-27.09 dBm	-28.04 dBm	
DPSK Avg	-25.09 dBm	-27.08 dBm	-28.03 dBm	
DPSK Pk	-22.34 dBm	-24.31 dBm	-25.20 dBm	
Result	Pass	Pass	Pass	

3Mbps/sec	EUT Max			Limits
Hopping OFF	Low	Med	High	
Max difference	0.09 dB	0.05 dB	-0.03 dB	Max: 1.00 dB
Min difference	0.06 dB	0.02 dB	-0.02 dB	Min: -4.00 dB
Avg difference	0.08 dB	0.04 dB	-0.02 dB	
GFSK Max	8.06 dBm	7.25 dBm	6.40 dBm	
GFSK Min	8.02 dBm	7.23 dBm	6.39 dBm	
GFSK Avg	8.04 dBm	7.24 dBm	6.40 dBm	
GFSK Pk	8.27 dBm	7.48 dBm	6.62 dBm	
DPSK Max	8.14 dBm	7.29 dBm	6.38 dBm	
DPSK Min	8.10 dBm	7.26 dBm	6.36 dBm	
DPSK Avg	8.11 dBm	7.28 dBm	6.37 dBm	
DPSK Pk	10.54 dBm	9.65 dBm	8.59 dBm	
Result	Pass	Pass	Pass	

3Mbits/sec

Hopping OFF	Low	EUT Min	High	Limits
Max difference	0.29 dB	0.29 dB	0.30 dB	Max: 1.00 dB
Min difference	0.27 dB	0.27 dB	0.26 dB	Min: -4.00 dB
Avg difference	0.28 dB	0.28 dB	0.29 dB	
GFSK Max	-25.36 dBm	-27.35 dBm	-28.31 dBm	
GFSK Min	-25.37 dBm	-27.37 dBm	-28.33 dBm	
GFSK Avg	-25.36 dBm	-27.36 dBm	-28.31 dBm	
GFSK Pk	-25.14 dBm	-27.18 dBm	-28.10 dBm	
DPSK Max	-25.08 dBm	-27.07 dBm	-28.03 dBm	
DPSK Min	-25.11 dBm	-27.10 dBm	-28.05 dBm	
DPSK Avg	-25.09 dBm	-27.08 dBm	-28.03 dBm	
DPSK Pk	-22.24 dBm	-24.21 dBm	-25.11 dBm	
Result	Pass	Pass	Pass	

TRM/CA/11/C (EDR Carrier Frequency Stability and Modulation Accuracy)

2Mbps Packet Length: 2-DH5, 3Mbps Packet Length: 3-DH5

Hopping OFF	Low	Med	High	Limits
Initial Frequency Error	21.7 kHz	20.7 kHz	19.1 kHz	-75 kHz < ω_i < 75 kHz
Frequency Error	1.1 kHz	-1.5 kHz	1.6 kHz	-10 kHz < ω_0 < 10 kHz
Block Frequency Error	22.1 kHz	20.7 kHz	19.4 kHz	-75 kHz < $\omega_i + \omega_0$ < 75 kHz
RMS DEVM	0.054	0.059	0.061	<= 0.2 (2Mbps)
Peak DEVM	0.136	0.156	0.157	<= 0.35 (2Mbps)
99% DEVM	100.00%	100.00%	100.00%	% Symbols <= 0.3 (2Mbps)
Average RMS DEVM	0.042	0.047	0.051	
Result	Pass	Pass	Pass	
Hopping OFF	Low	Med	High	Limits
Initial Frequency Error	21.4 kHz	20.3 kHz	19.5 kHz	-75 kHz < ω_i < 75 kHz
Frequency Error	1.3 kHz	-1.2 kHz	-2 kHz	-10 kHz < ω_0 < 10 kHz
Block Frequency Error	22.1 kHz	20.9 kHz	19.5 kHz	-75 kHz < $\omega_i + \omega_0$ < 75 kHz
RMS DEVM	0.052	0.058	0.063	<= 0.13 (3Mbps)
Peak DEVM	0.132	0.140	0.159	<= 0.25 (3Mbps)
99% DEVM	100.00%	100.00%	100.00%	% Symbols <= 0.2 (3Mbps)
Average RMS DEVM	0.041	0.044	0.049	
Result	Pass	Pass	Pass	

TRM/CA/12/C (EDR Differential Phase Encoding)

2Mbps Packet Length: 2-DH1, 3Mbps Packet Length: 3-DH1

Hopping OFF	Low	Med	High	Limits
Packets Received	100	n/a	n/a	
Packets in Error	0	n/a	n/a	
Percentage	100%	n/a	n/a	99 %
CFC FERs	0	n/a	n/a	
Length FERs	0	n/a	n/a	
Lost Pkt FERs	0	n/a	n/a	
Result	Pass	n/a	n/a	
Hopping OFF <td>Low <td>Med <td>High <td>Limits</td> </td></td></td>	Low <td>Med <td>High <td>Limits</td> </td></td>	Med <td>High <td>Limits</td> </td>	High <td>Limits</td>	Limits
Packets Received	100	n/a	n/a	
Packets in Error	0	n/a	n/a	
Percentage	100%	n/a	n/a	99 %
CFC FERs	0	n/a	n/a	
Length FERs	0	n/a	n/a	
Lost Pkt FERs	0	n/a	n/a	
Result	Pass	n/a	n/a	

RCV/CA/07/C (EDR Sensitivity)

Power Level: -86 dBm, Dirty Tx Status: ON, 2Mbps Packet Length: 2-DH5, 3Mbps Packet Length: 3-DH5

Hopping OFF	Low	Med	High	Limits
Overall BER	0.00E+000	0.00E+000	0.00E+000	7.0E-005
Bits in error	0	0	0	1.0E-004
Packets sent	300	300	300	
Packets in error	1	0	0	
CFC FERs	0	0	0	
Length FERs	0	0	0	
Lost Pkt FERs	1	0	0	
Packets received	299	300	300	
Result	Pass	Pass	Pass	

Hopping OFF	Low	Med	High	Limits
Overall BER	1.81E-005	1.98E-005	5.25E-006	7.0E-005
Bits in error	31	34	9	1.0E-004
Packets sent	210	210	210	
Packets in error	27	23	9	
CFC FERs	27	23	9	
Length FERs	0	0	0	
Lost Pkt FERs	0	0	0	
Packets received	210	210	210	
Result	Pass	Pass	Pass	

RCV/CA/08/C (EDR BER Floor Sensitivity)

Power Level: -86 dBm, 2Mbps Packet Length: 2-DH5, 3Mbps Packet Length: 3-DH5

	<u>2Mbits/sec</u>			
Hopping OFF	<u>Low</u>	<u>Med</u>	<u>High</u>	<u>Limits</u>
Overall BER	0.00E+000	0.00E+000	0.00E+000	7.00E-006
Bits in error	0	0	0	1.00E-005
Packets sent	1500	1500	1500	
Packets in error	0	0	0	
CFC FERs	0	0	0	
Length FERs	0	0	0	
Lost Pkt FERs	0	0	0	
Packets received	1500	1500	1500	
Result	Pass	Pass	Pass	

	<u>3Mbits/sec</u>			
Hopping OFF	<u>Low</u>	<u>Med</u>	<u>High</u>	<u>Limits</u>
Overall BER	1.48E-006	6.93E-006	1.85E-006	7.00E-006
Bits in error	12	56	15	1.00E-005
Packets sent	990	990	990	
Packets in error	12	24	12	
CFC FERs	12	24	12	
Length FERs	0	0	0	
Lost Pkt FERs	0	0	0	
Packets received	990	990	990	
Result	Pass	Pass	Pass	

RCV/CA/10/C (EDR Maximum Input Power)

Power Level: -20 dBm, 2Mbps Packet Length: 2-DH5, 3Mbps Packet Length: 3-DH5

	<u>2Mbits/sec</u>			
Hopping OFF	<u>Low</u>	<u>Med</u>	<u>High</u>	<u>Limits</u>
Overall BER	0.00E+000	0.00E+000	0.00E+000	1.00E-003
Bits in error	0	0	0	
Packets sent	295	295	295	
Packets in error	1	0	0	
CFC FERs	0	0	0	
Length FERs	0	0	0	
Lost Pkt FERs	1	0	0	
Packets received	294	295	295	
Result	Pass	Pass	Pass	

	<u>3Mbits/sec</u>			
Hopping OFF	<u>Low</u>	<u>Med</u>	<u>High</u>	<u>Limits</u>
Overall BER	0.00E+000	0.00E+000	0.00E+000	1.00E-003
Bits in error	0	0	0	
Packets sent	196	196	196	
Packets in error	0	0	0	
CFC FERs	0	0	0	
Length FERs	0	0	0	
Lost Pkt FERs	0	0	0	
Packets received	196	196	196	
Result	Pass	Pass	Pass	

---- Report End ----

BPI-M2+ WIFI Lab test

Date: 2016/3/25

Overall Result: **PASS**

AP 6212 wifi 802.11 B test report

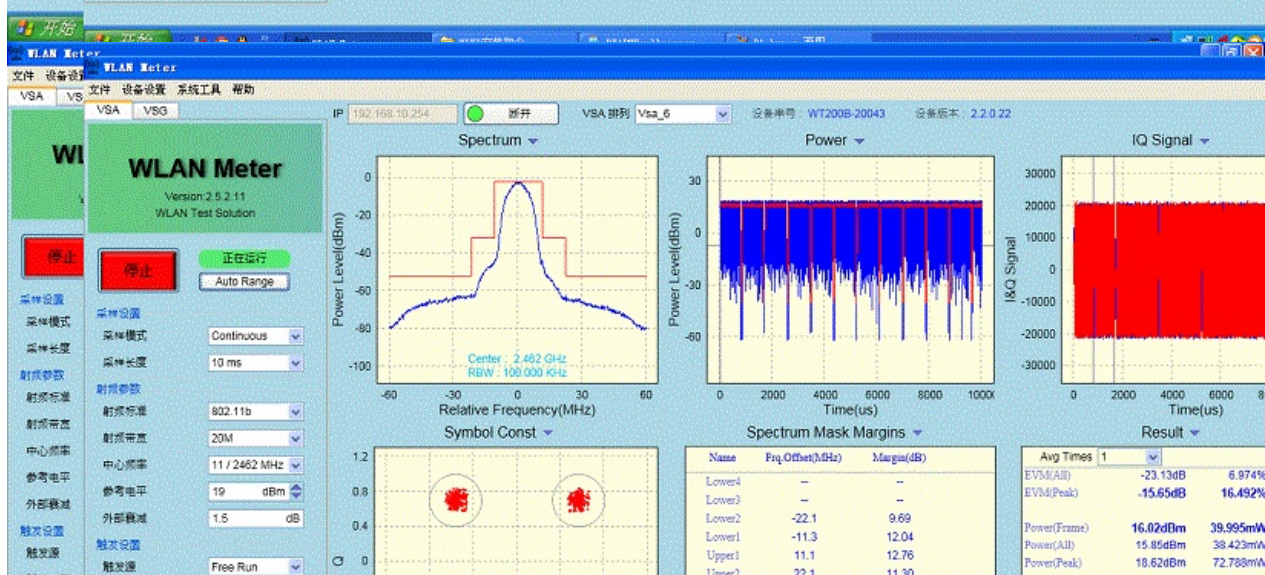
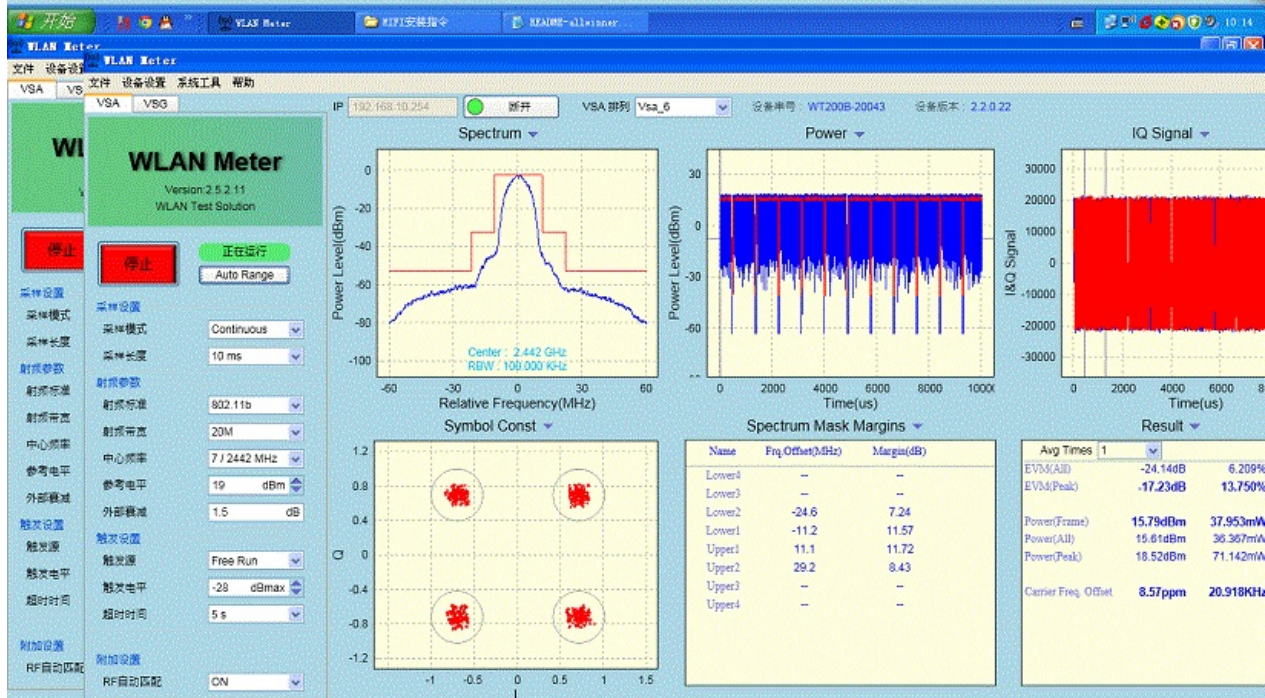
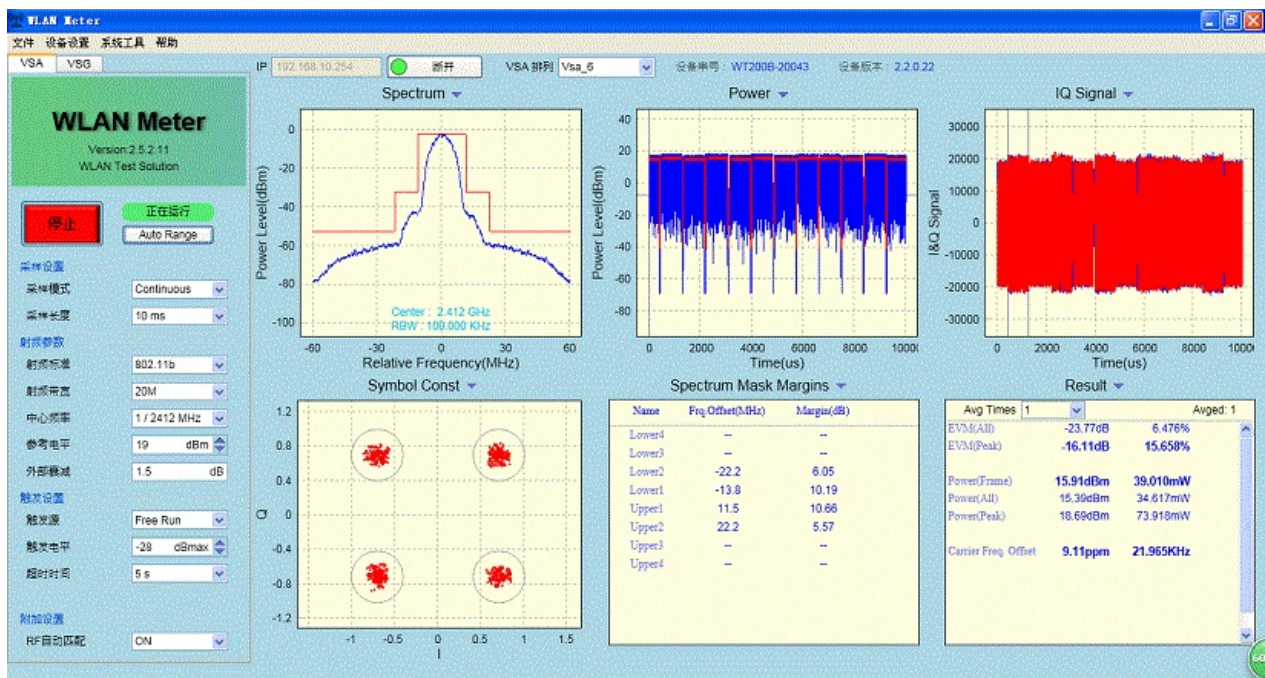

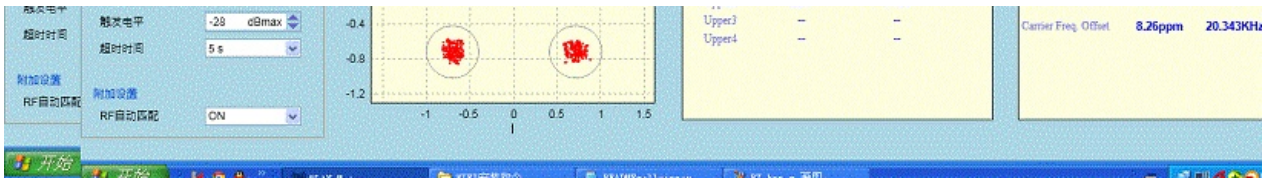

AP 6212 wifi 802.11 G test report

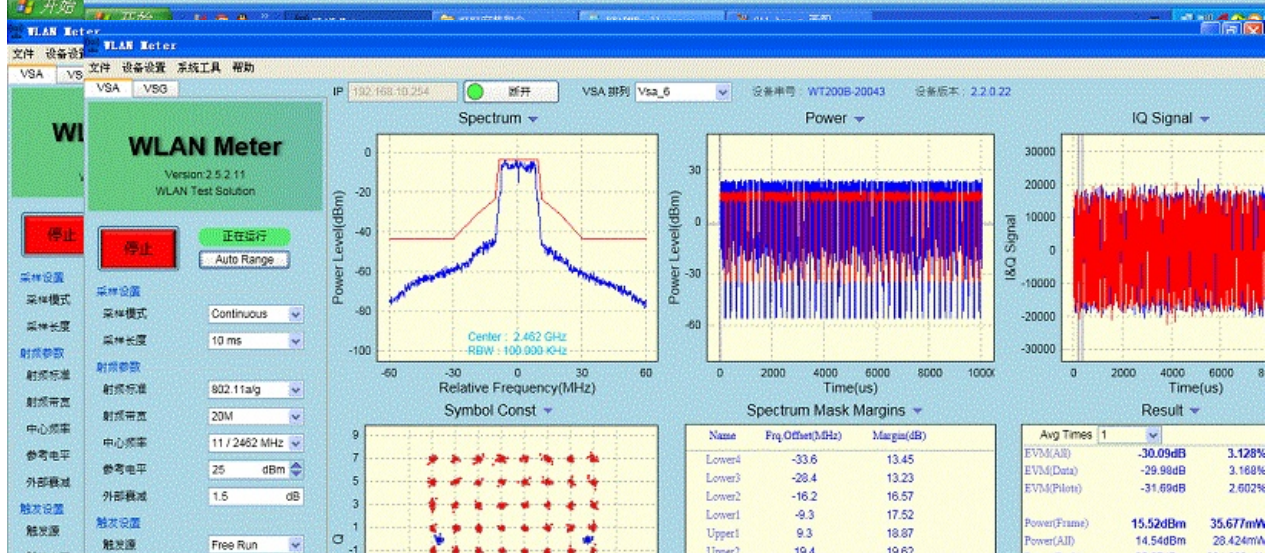
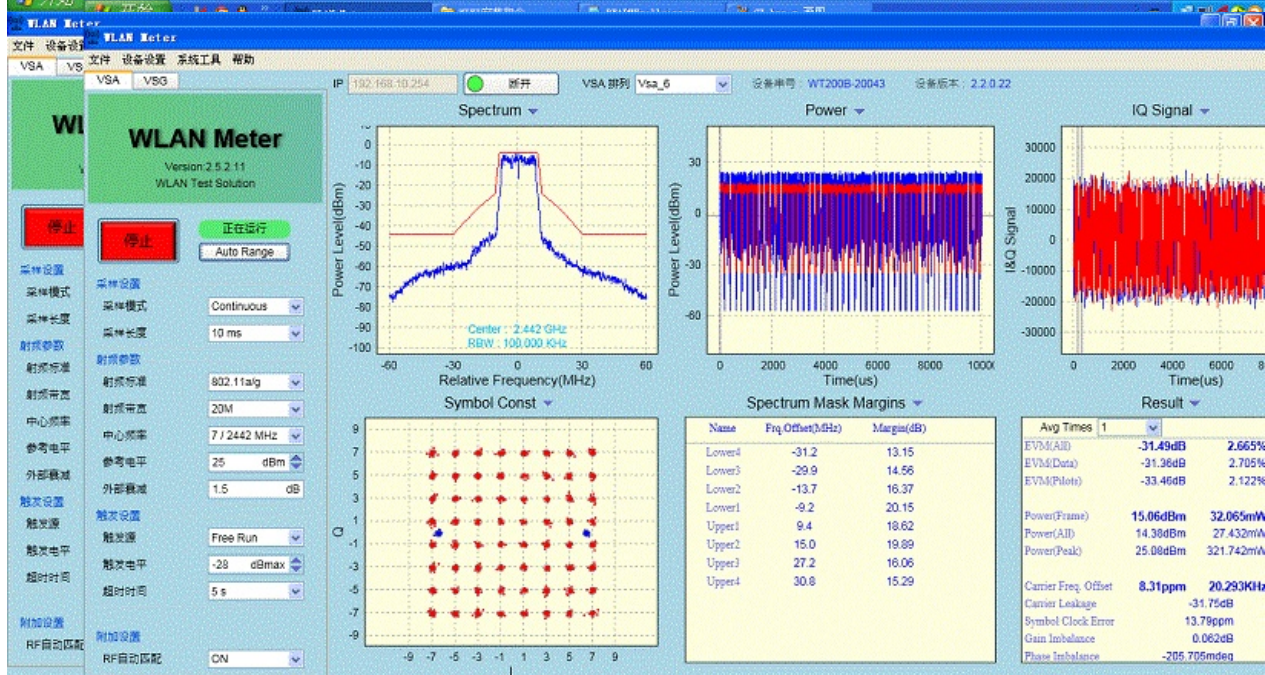
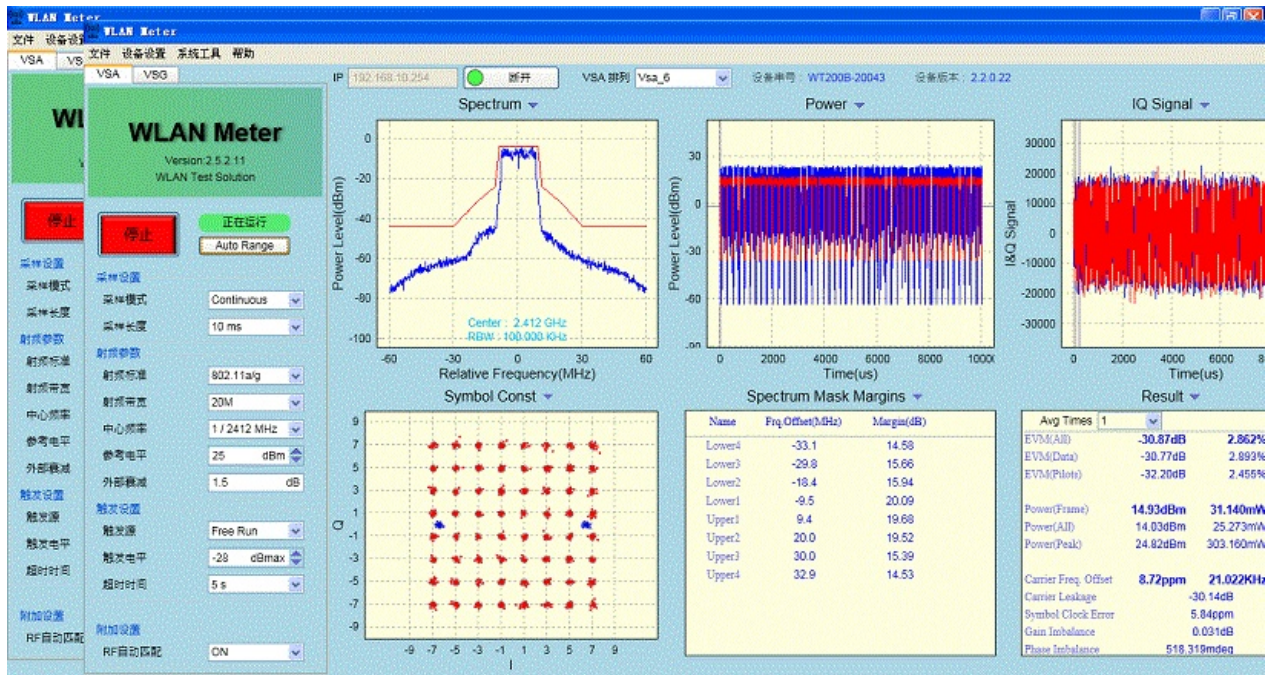

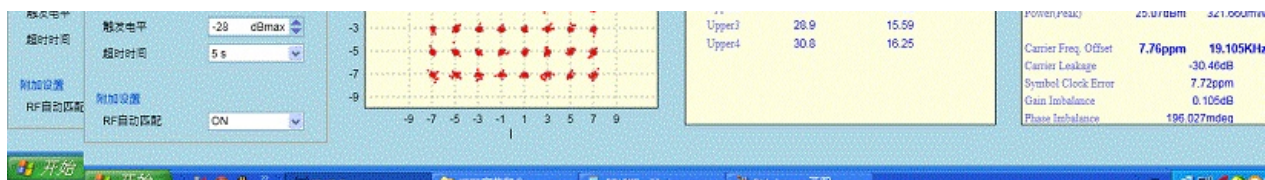

AP 6212 wifi 802.11 N test report

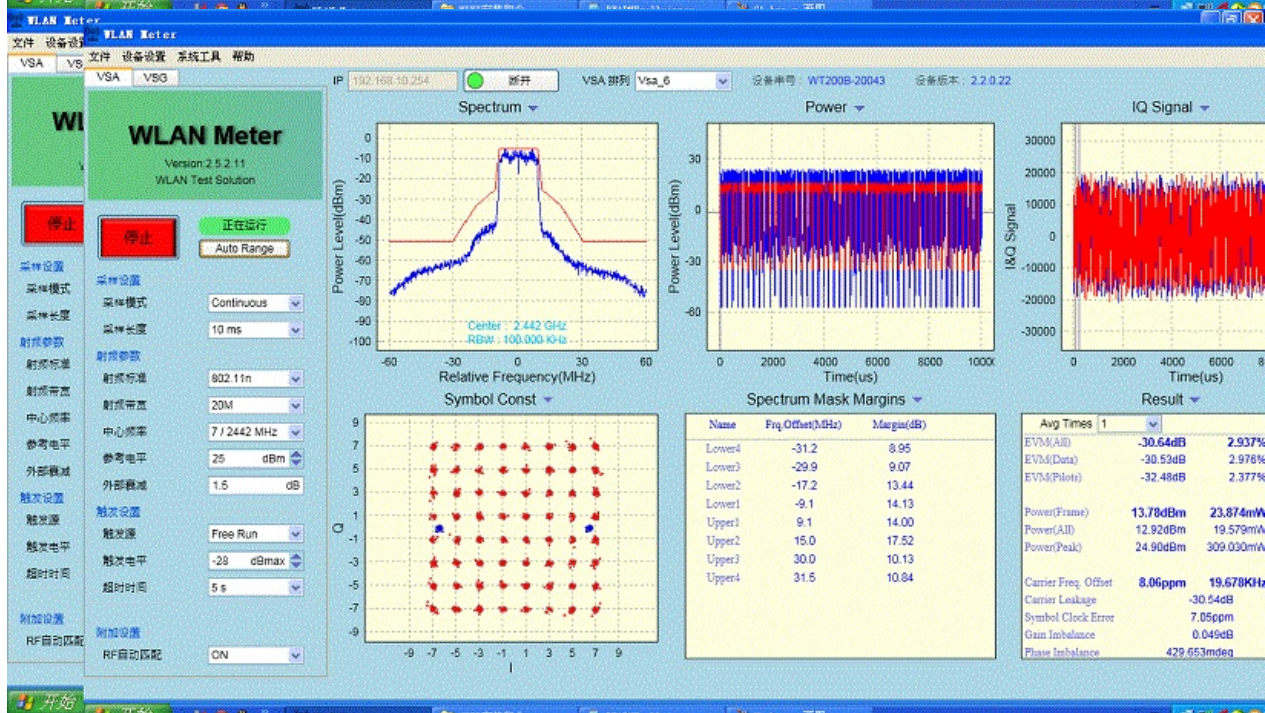
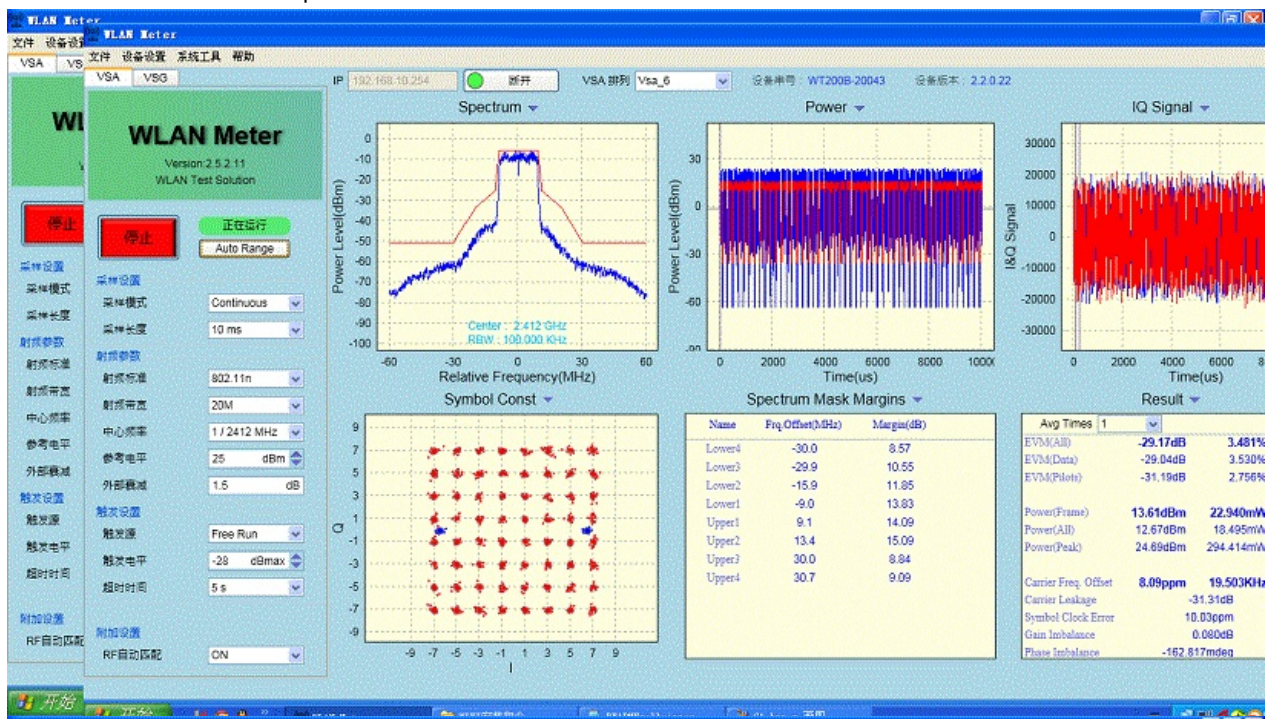

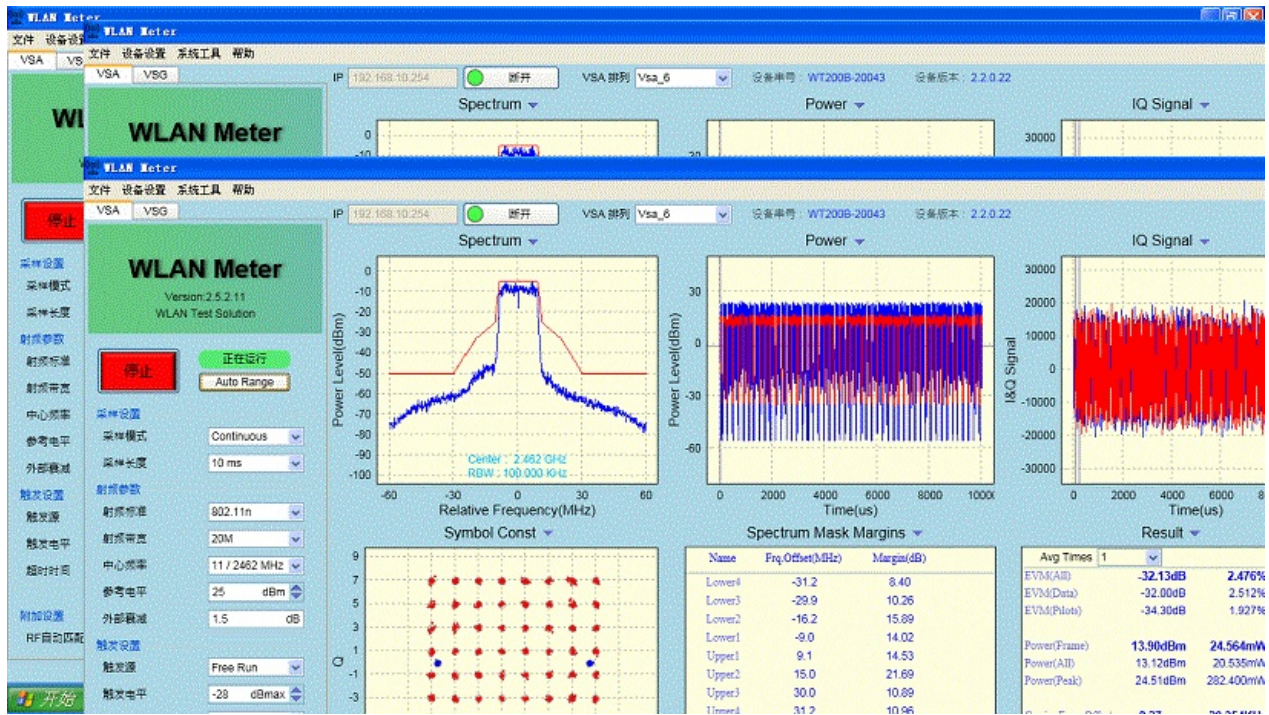

BPI-M2+ validation test report

banana pi BPI-M2+ have do all hardware validation test ,and all function passed.

include :

HDMI 720P validation test

HDMI 1080P validation test

WIFI BT validation test

USB validation test

DDR validation test

Power validation test

BPI-M2+ HDMI 720P validation report

Test Case: HDMI Interface	
29	Tests Planned
29	Tests Attempted
29	Tests Passed
0	Tests Blocked
0	Tests Failed

DUT Information	
Model name	BananaPI
OS	Android

Test Equipments
 1.Scope: Tektronix DSA72004 Digital Serial Analyzer Oscilloscope
 2.Probe: Tektronix P7313SMA (19GHz/WB)*2
 3.Test Fixture: HDMI Test Board

Test Software
 Test Software: HDMI Compliance test solution V4.0.5

Ref Documents
 HDMI Specification: High-Definition Multimedia Interface Revision: 1.4
 High-Definition Multimedia Interface Compliance Test Specification Revision: 1.3b

第 1 頁

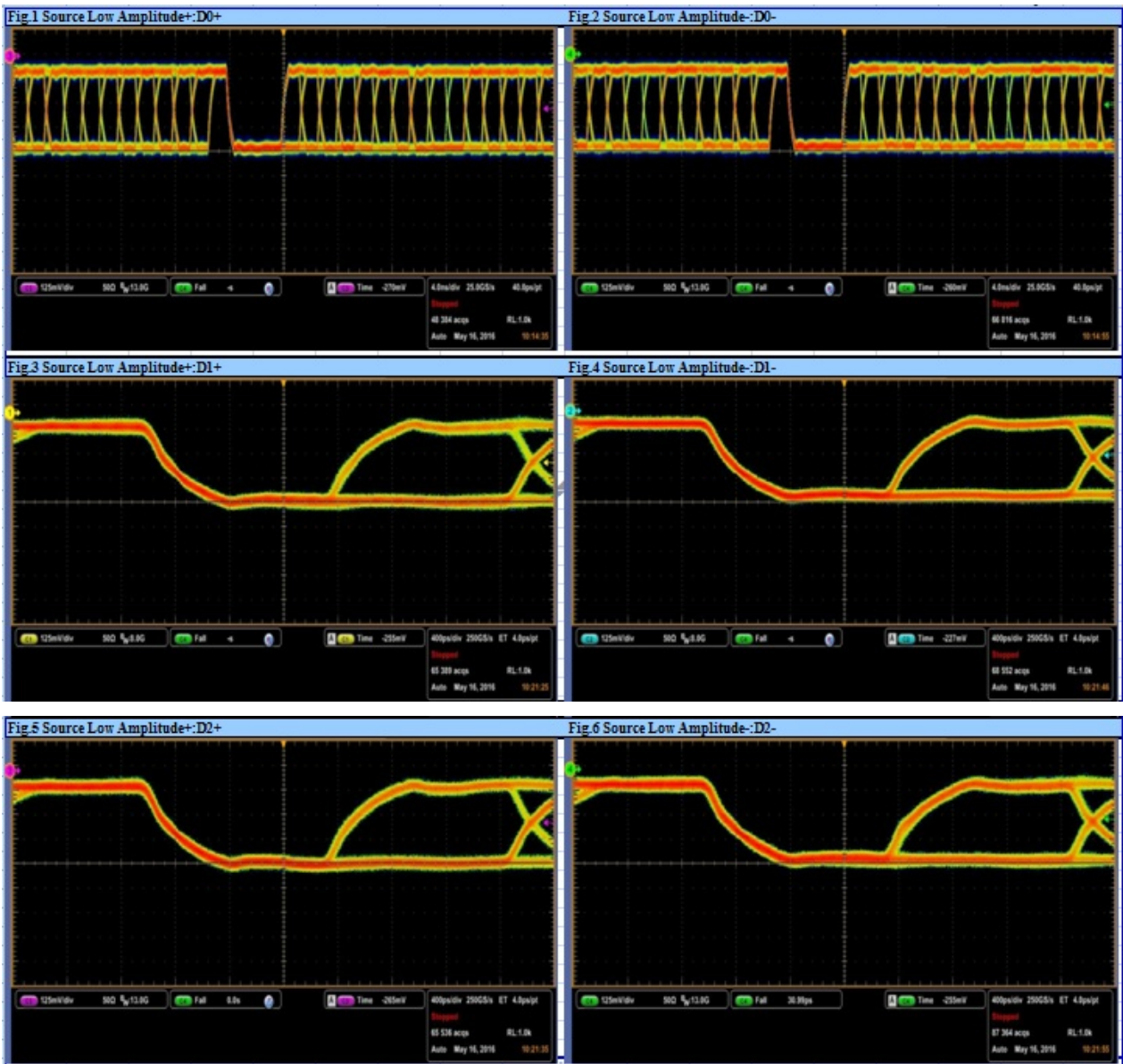

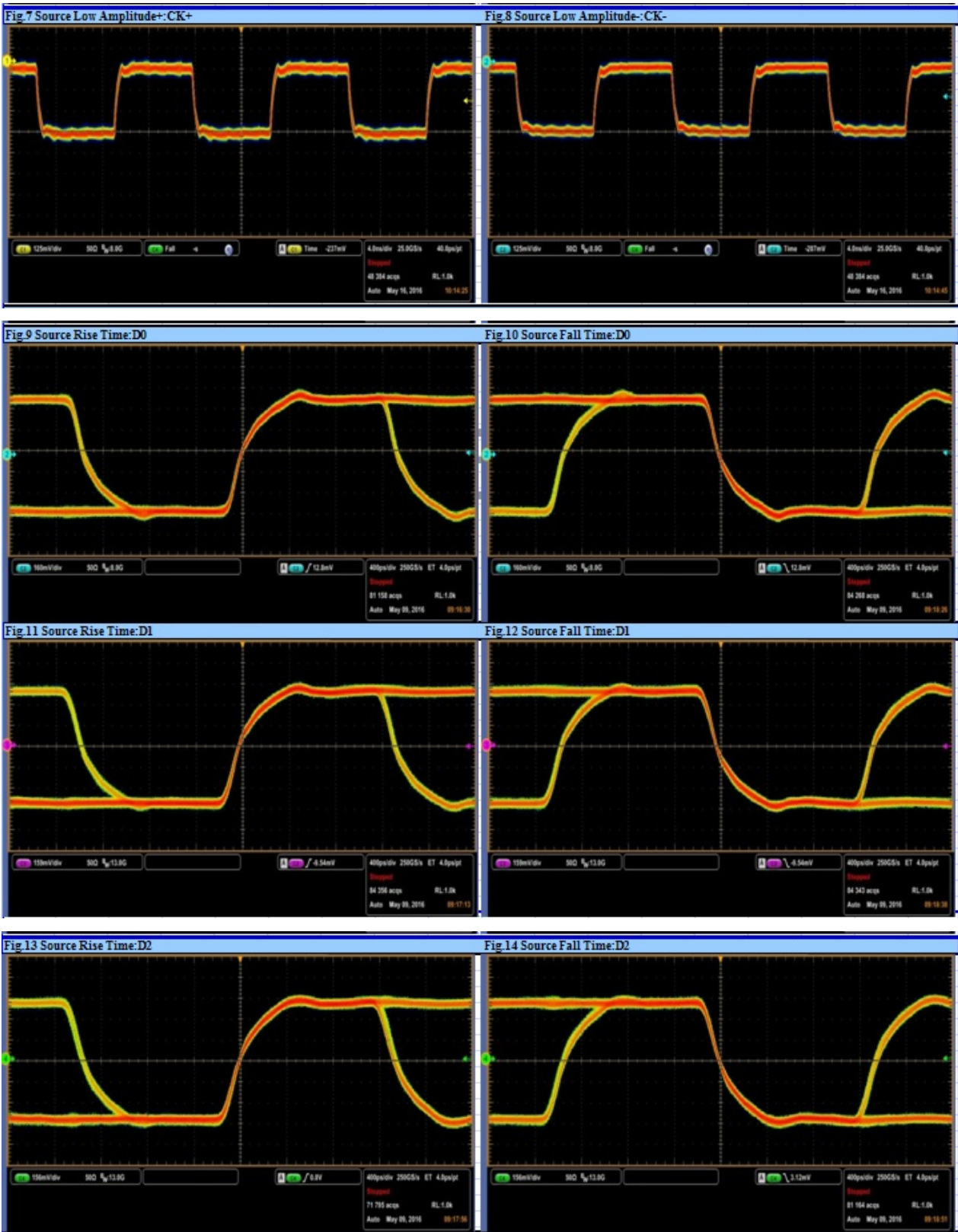

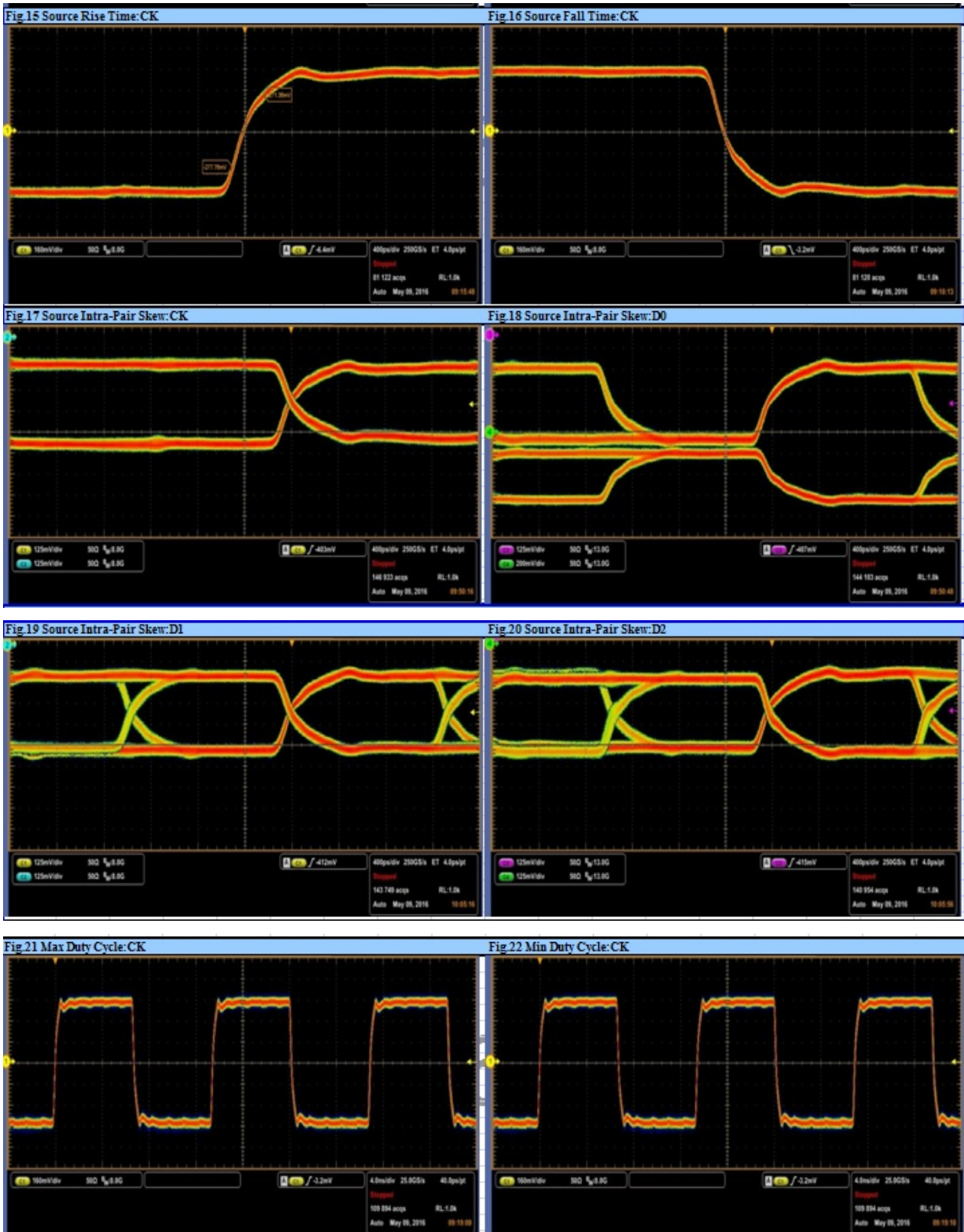

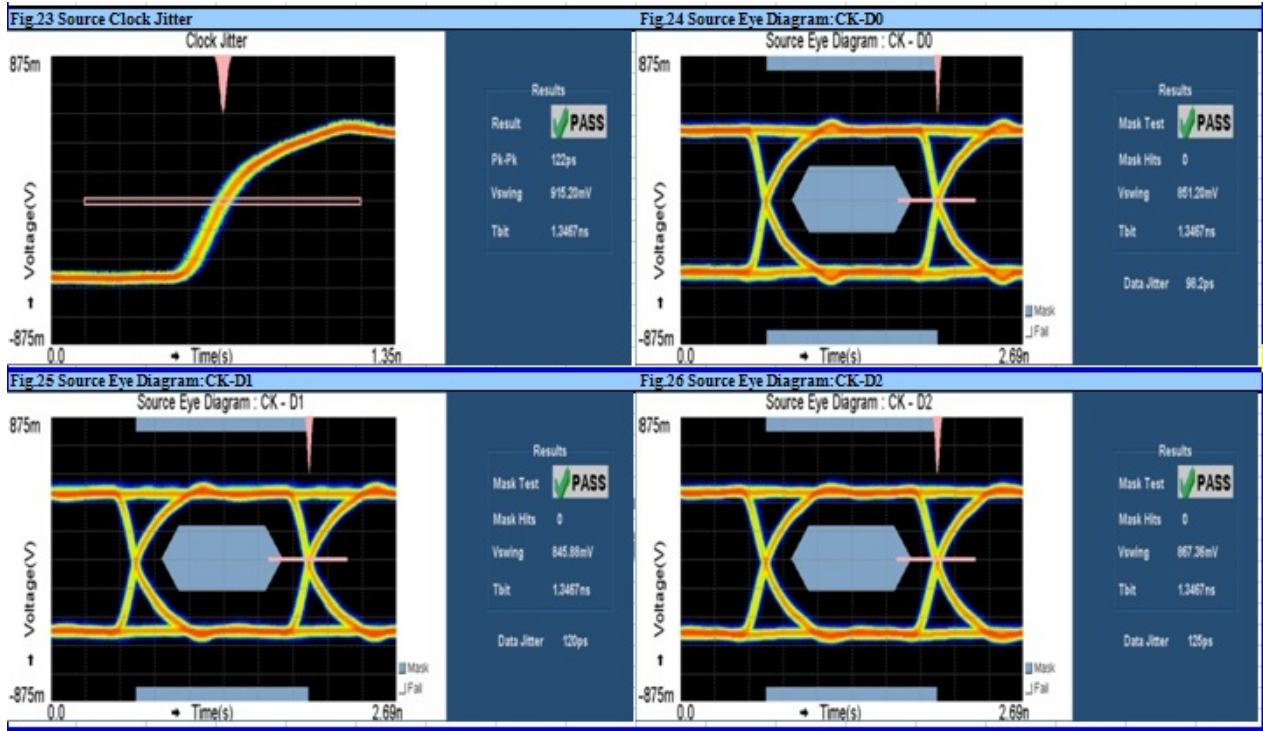

BPI-M2+ HDMI 1080P validation report

Test Case: HDMI Interface	
29	Tests Planned
29	Tests Attempted
29	Tests Passed
0	Tests Blocked
0	Tests Failed

DUT Information	
Model name	BananaPi
OS	Android

Test Equipments
 1. Scope: Tektronix DSA72004 Digital Serial Analyzer Oscilloscope
 2. Probe: Tektronix P7313SMA (13GHz/WB)*2
 3. Test Fixture: HDMI Test Board

Test Software
 Test Software: HDMI Compliance test solution V4.0.5

Ref Documents
 HDMI Specification: High-Definition Multimedia Interface Revision: 1.4
 High-Definition Multimedia Interface Compliance Test Specification Revision: 1.3b

第 1 頁

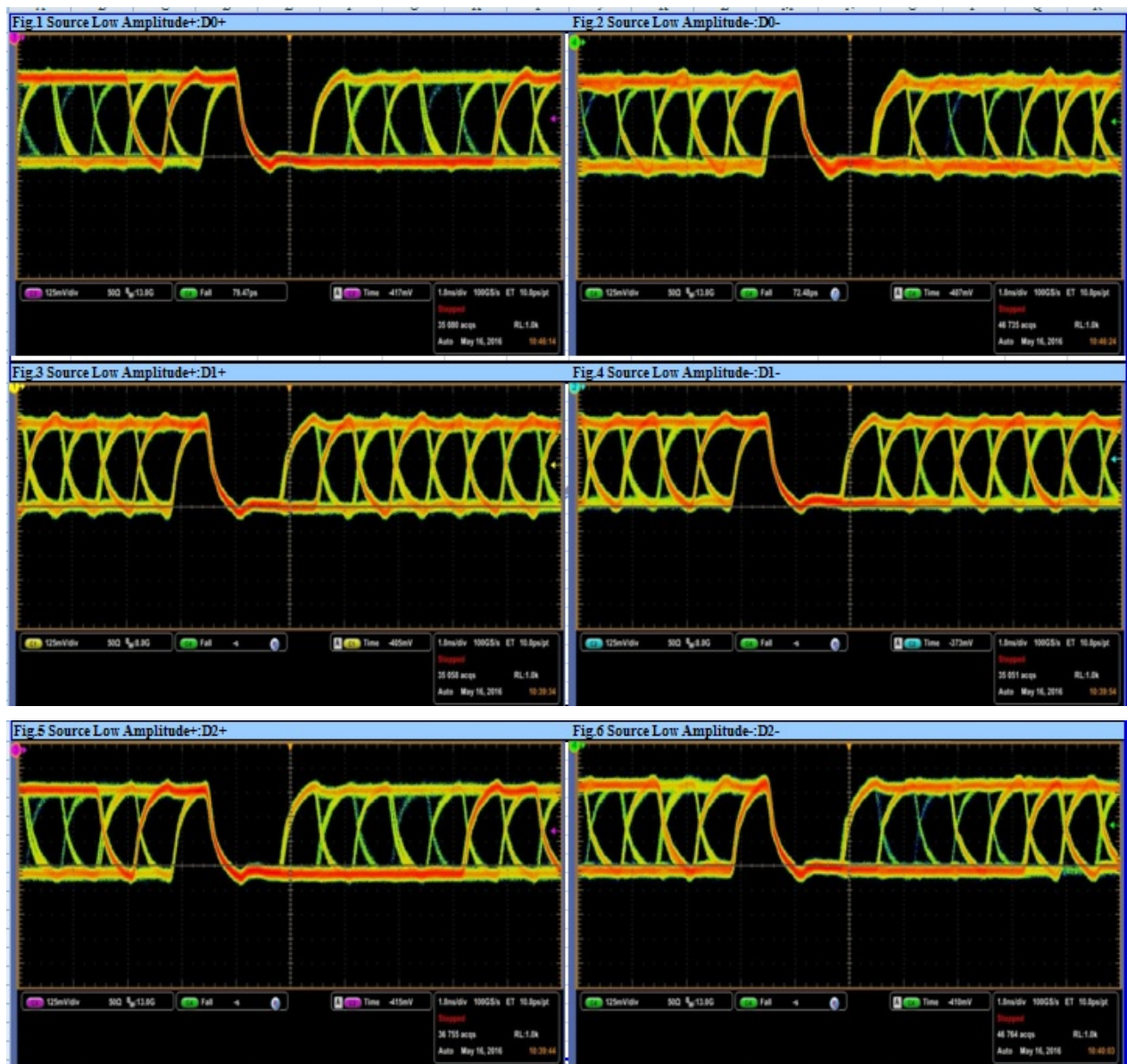

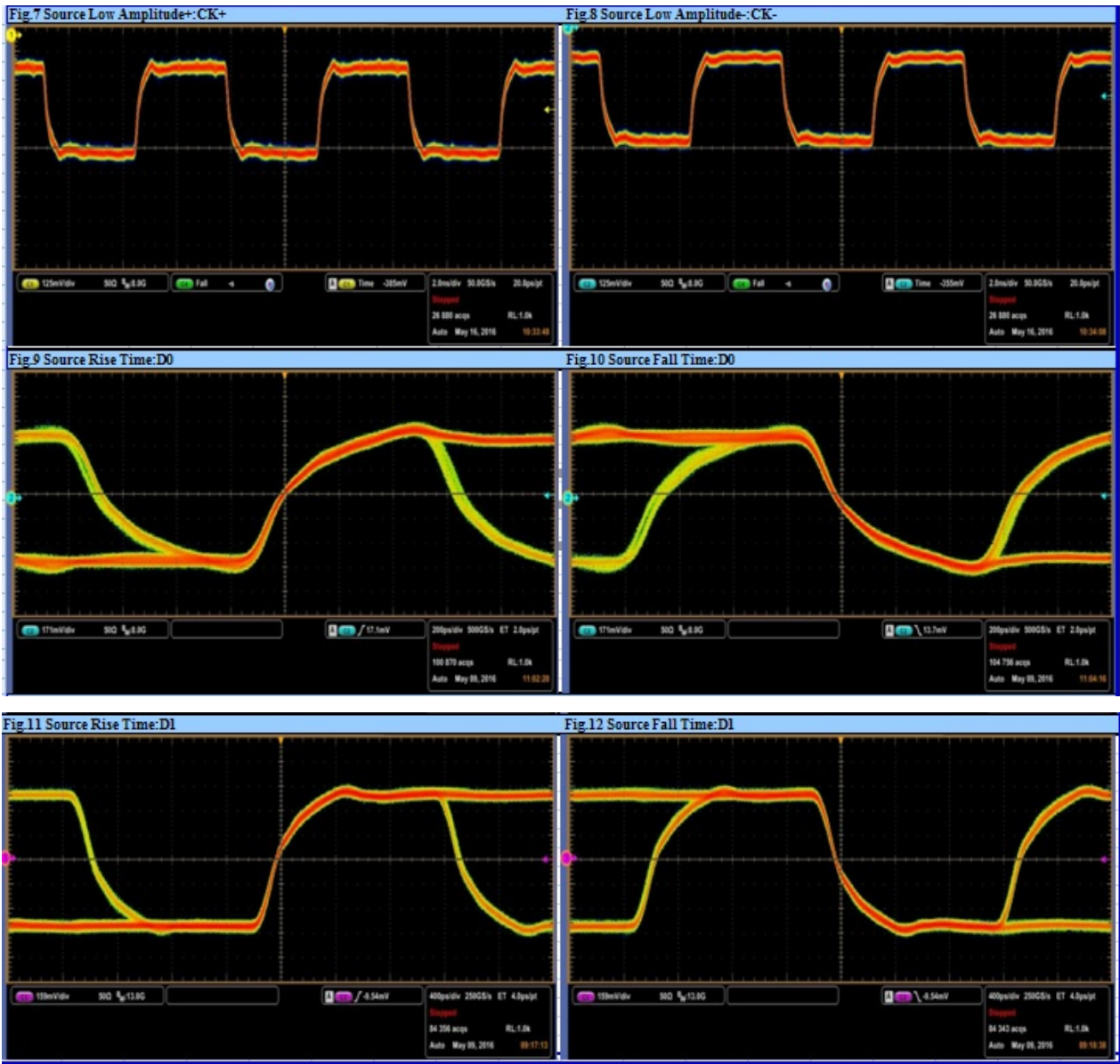

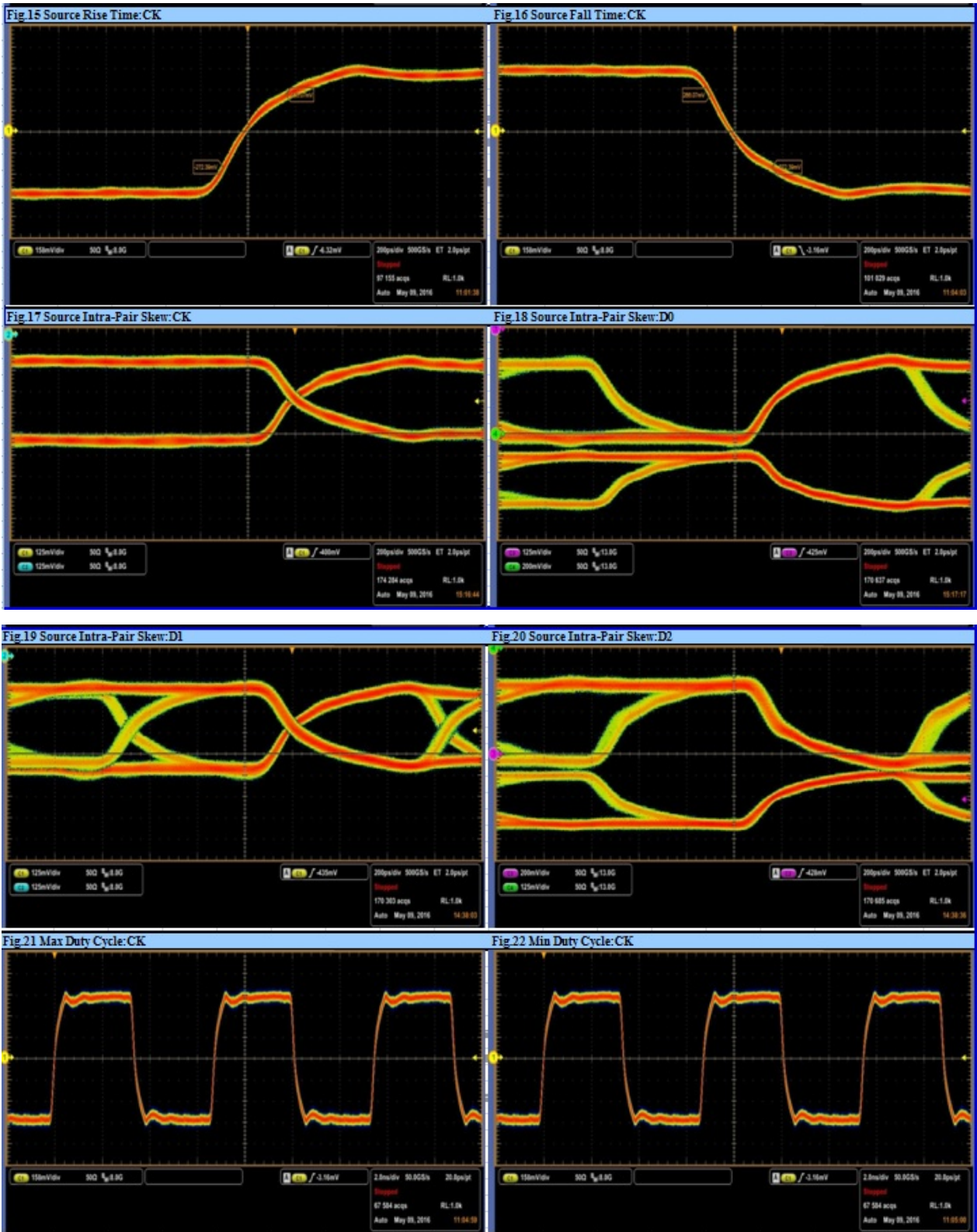

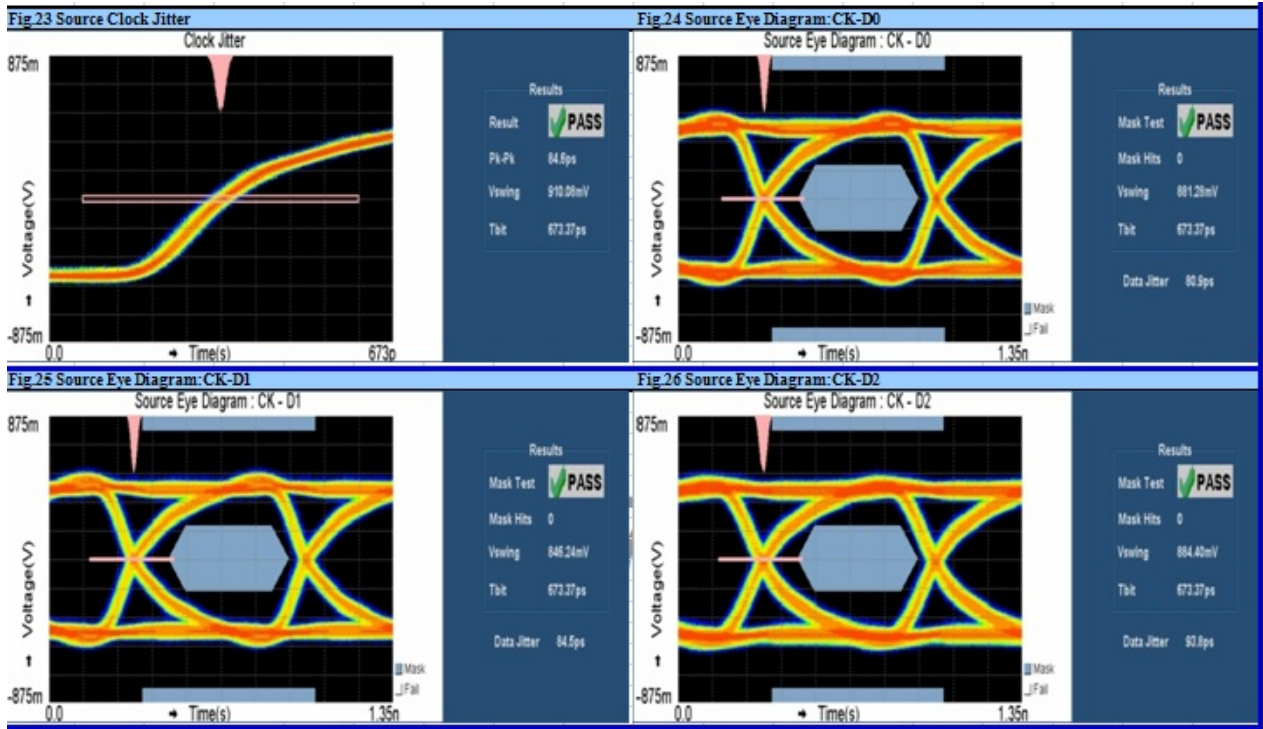

BPI-M2+ WIFI&BT validation report

樣品編號	IMEI/ESN/MEID	硬體版本	Build number	Kernel version
WU160506001	N/A	H3	dolphin_bpi_m2p -eng 4.4.2 KOT49H 20160501 test- keys	3.4.39justin@just in-ThinkPad- T420#1 Sun May 1 19:10:57 CST 2016

- 測試開始時間： 2016/5/10 10:46
- 實際環境溫度： 19.8°C~22.5°C
- 實際環境濕度： 65%~70%
- 測試結束時間： 2016/5/11 10:55
- 規範環境溫度： 15°C~35°C
- 規範環境濕度： 25%~75%

設備清單：

設備/系統	設備編號	型號	校準日期	校準週期(月)
藍牙信號測試儀	LAB0202	CBT	2016/4/5	12
通用無線通訊測試儀	LAB0284	N4010A	2016/3/25	12

WiFi測試專案目錄——測試頻段（2.4GHz）

數據編號	測試項目	測試協議	測試結果判定	失效描述
1	ETSI TX average output power	802.11a/b/g/n	PASS	
2	FCC TX peak effective power	802.11a/b/g/n	PASS	
3	IEEE TX spectral flatness	802.11a/g/n	PASS	
4	IEEE Transmit center frequency tolerance	802.11a/b/g/n	PASS	
5	IEEE Transmit spectrum mask	802.11a/b/g/n	PASS	
6	IEEE Transmit power-on and power-down ramp	802.11b	PASS	
7	IEEE Modulation accuracy (EVM)	802.11a/b/g/n	PASS	
8	IEEE PER search sensitivity	802.11a/b/g/n	PASS	
9	IEEE Maximum input level	802.11a/b/g/n	PASS	
10	IEEE Chip clock Error	802.11b	PASS	
11	IEEE Sym.clock error	802.11a/g/n	PASS	

樣品編號	IMEI/ESN/MEID	硬體版本	Build number	Kernel version
WU160506001	N/A	H3	dolphin_bpi_m2p -eng 4.4.2 KOT49H 20160501 test- keys	3.4.39justin@just in-ThinkPad- T420#1 Sun May 1 19:10:57 CST 2016

- 測試開始時間： 2016/5/10 10:46
- 實際環境溫度： 19.8°C~22.5°C
- 實際環境濕度： 65%~70%
- 測試結束時間： 2016/5/11 10:55
- 規範環境溫度： 15°C~35°C
- 規範環境濕度： 25%~75%

設備清單：

設備/系統	設備編號	型號	校準日期	校準週期(月)
藍牙信號測試儀	LAB0202	CBT	2016/4/5	12
通用無線通訊測試儀	LAB0284	N4010A	2016/3/25	12

WiFi測試專案目錄——測試頻段（2.4GHz）

數據編號	測試項目	測試協議	測試結果判定	失效描述
1	ETSI TX average output power	802.11a/b/g/n	PASS	
2	FCC TX peak effective power	802.11a/b/g/n	PASS	
3	IEEE TX spectral flatness	802.11a/g/n	PASS	
4	IEEE Transmit center frequency tolerance	802.11a/b/g/n	PASS	
5	IEEE Transmit spectrum mask	802.11a/b/g/n	PASS	
6	IEEE Transmit power-on and power-down ramp	802.11b	PASS	
7	IEEE Modulation accuracy (EVM)	802.11a/b/g/n	PASS	
8	IEEE PER search sensitivity	802.11a/b/g/n	PASS	
9	IEEE Maximum input level	802.11a/b/g/n	PASS	
10	IEEE Chip clock Error	802.11b	PASS	
11	IEEE Sym.clock error	802.11a/g/n	PASS	

BT測試專案目錄——測試頻段（2.4GHz）

編號	測試項目	測試規範	測試結果判定	備註
1	Output Power	RF.TS.2.1.E.3 : SPECIFICATION 1.2/2.0/2.0 + EDR/2.1/2.1 + EDR	PASS	
2	Power Control	RF.TS.2.1.E.3 : SPECIFICATION 1.2/2.0/2.0 + EDR/2.1/2.1 + EDR	PASS	
3	Frequency range	RF.TS.2.1.E.3 : SPECIFICATION 1.2/2.0/2.0 + EDR/2.1/2.1 + EDR	PASS	

8	Carrier Frequency Drift	RF.TS.2.1.E.3 : SPECIFICATION 1.2/2.0/2.0 + EDR/2.1/2.1 + EDR	PASS	
9	EDR Relative Transmit Power	RF.TS.2.1.E.3 : SPECIFICATION 1.2/2.0/2.0 + EDR/2.1/2.1 + EDR	PASS	
10	EDR Carrier Frequency Stability and Modulation Accuracy	RF.TS.2.1.E.3 : SPECIFICATION 1.2/2.0/2.0 + EDR/2.1/2.1 + EDR	PASS	
11	EDR Differential Phase Encoding	RF.TS.2.1.E.3 : SPECIFICATION 1.2/2.0/2.0 + EDR/2.1/2.1 + EDR	PASS	
12	EDR In-band Spurious Emission	RF.TS.2.1.E.3 : SPECIFICATION 1.2/2.0/2.0 + EDR/2.1/2.1 + EDR	PASS	
13	Sensitivity – Single Slot Packets	RF.TS.2.1.E.3 : SPECIFICATION 1.2/2.0/2.0 + EDR/2.1/2.1 + EDR	PASS	
14	Sensitivity – Multi-slot Packets	RF.TS.2.1.E.3 : SPECIFICATION 1.2/2.0/2.0 + EDR/2.1/2.1 + EDR	PASS	
15	Maximum Input Level	RF.TS.2.1.E.3 : SPECIFICATION 1.2/2.0/2.0 + EDR/2.1/2.1 + EDR	PASS	
16	EDR Sensitivity	RF.TS.2.1.E.3 : SPECIFICATION 1.2/2.0/2.0 + EDR/2.1/2.1 + EDR	PASS	
17	EDR BER Floor Performance	RF.TS.2.1.E.3 : SPECIFICATION 1.2/2.0/2.0 + EDR/2.1/2.1 + EDR	PASS	

14	Sensitivity – Multi-slot Packets	RF.TS.2.1.E.3 : SPECIFICATION 1.2/2.0/2.0 + EDR/2.1/2.1 + EDR	PASS	
15	Maximum Input Level	RF.TS.2.1.E.3 : SPECIFICATION 1.2/2.0/2.0 + EDR/2.1/2.1 + EDR	PASS	
16	EDR Sensitivity	RF.TS.2.1.E.3 : SPECIFICATION 1.2/2.0/2.0 + EDR/2.1/2.1 + EDR	PASS	
17	EDR BER Floor Performance	RF.TS.2.1.E.3 : SPECIFICATION 1.2/2.0/2.0 + EDR/2.1/2.1 + EDR	PASS	
18	EDR Maximum Input Level	RF.TS.2.1.E.3 : SPECIFICATION 1.2/2.0/2.0 + EDR/2.1/2.1 + EDR	PASS	

WiFi Test result						
線路損失 : 1dB				備註	802.11b 11Mbps 802.11a/g 54Mbps 802.11n MCS7	
802.11b						
	Channel		Channel		Channel	
ETSI TX average output power	CH1(2412MHz)	14.69dBm	CH 7(2442MHz)	14.49dBm	CH11(2462MHz)	14.84dBm
FCC TX peak effective power	CH1(2412MHz)	17.28dBm	CH 7(2442MHz)	17.01dBm	CH11(2462MHz)	17.37dBm
IEEE Transmit center frequency tolerance	CH1(2412MHz)	8.682ppm	CH 7(2442MHz)	8.424ppm	CH11(2462MHz)	8.264ppm
IEEE Transmit spectrum mask	CH1(2412MHz)	圖1	CH 7(2442MHz)	圖2	CH11(2462MHz)	圖3
IEEE Transmit power-on and power-down ramp	CH1(2412MHz)	圖4	CH 7(2442MHz)	圖5	CH11(2462MHz)	圖6
IEEE Modulation accuracy (EVM)	CH1(2412MHz)	10.27%	CH 7(2442MHz)	10.06%	CH11(2462MHz)	10.22%
802.11g						
	Channel		Channel		Channel	
ETSI TX average output power	CH1(2412MHz)	13.73dBm	CH7(2442MHz)	14.39dBm	CH11(2462MHz)	13.68dBm
FCC TX peak effective power	CH1(2412MHz)	21.34dBm	CH7(2442MHz)	22.26dBm	CH11(2462MHz)	21.45dBm
TX spectral flatness	CH1(2412MHz)	pass	CH7(2442MHz)	pass	CH11(2462MHz)	pass
IEEE Transmit center frequency tolerance	CH1(2412MHz)	8.319ppm	CH7(2442MHz)	8.336ppm	CH11(2462MHz)	8.337ppm
IEEE Transmit spectrum mask	CH1(2412MHz)	圖7	CH7(2442MHz)	圖8	CH11(2462MHz)	圖9
IEEE Modulation accuracy (EVM)	CH1(2412MHz)	4.34%	CH7(2442MHz)	4.38%	CH11(2462MHz)	4.54%

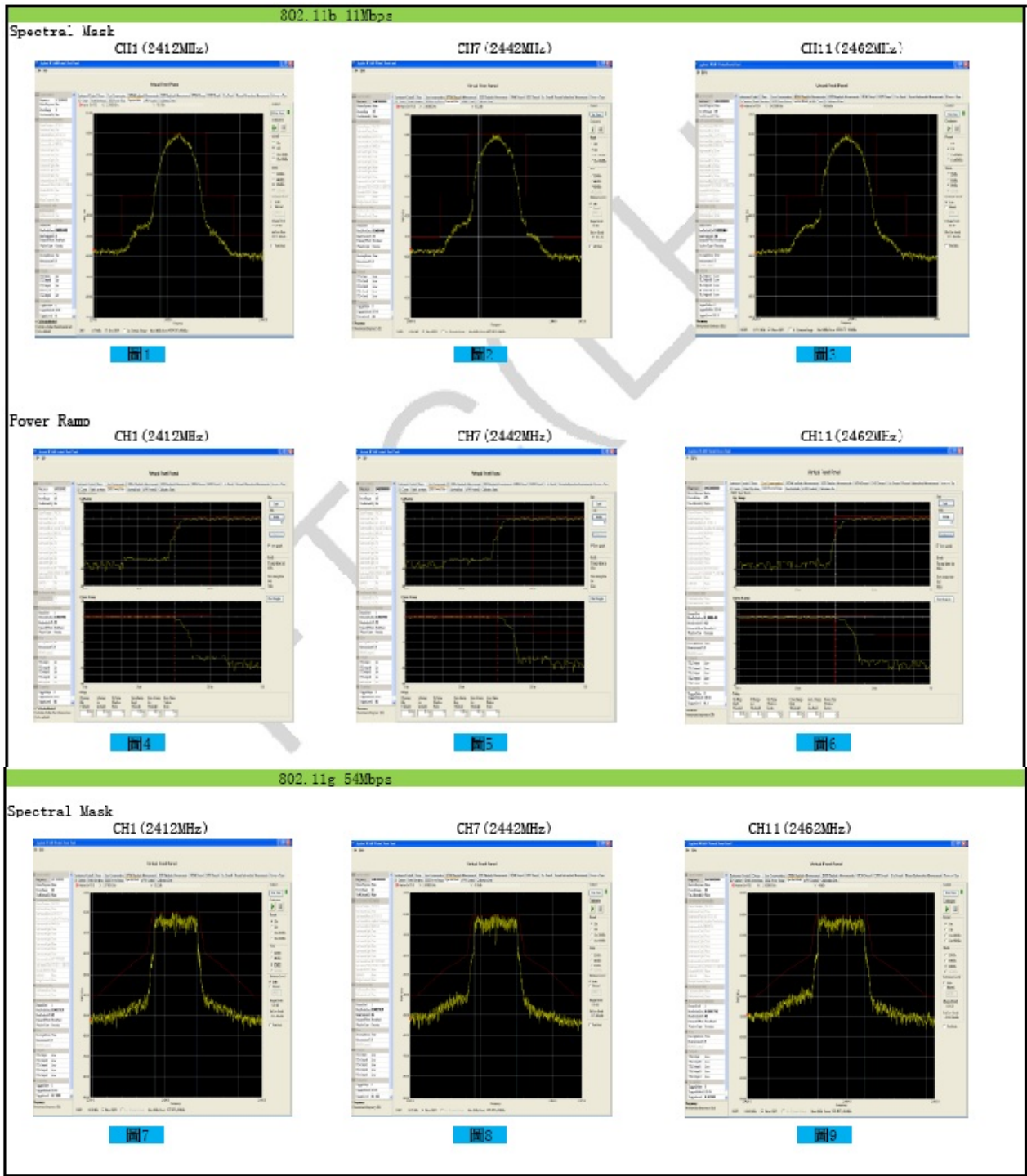

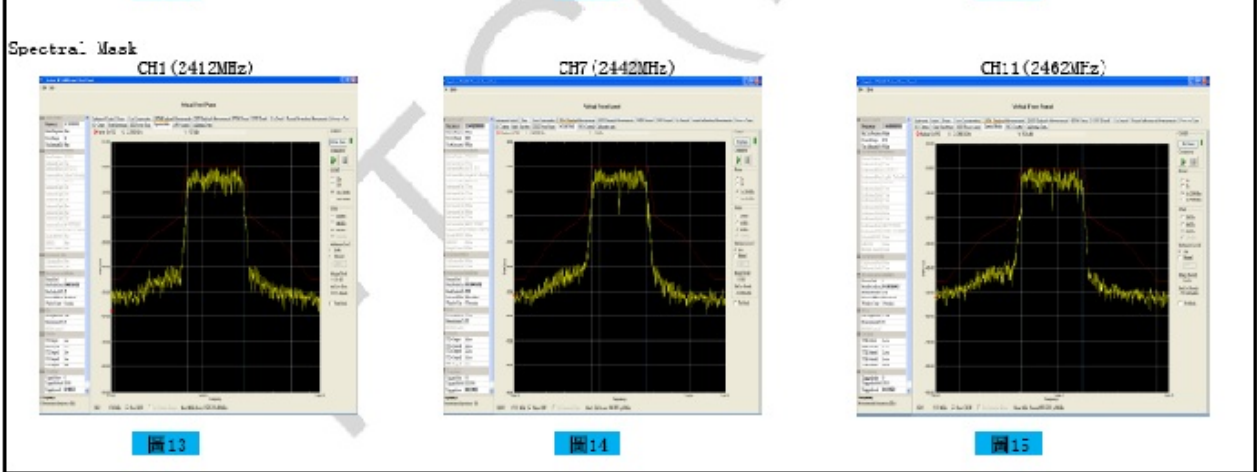
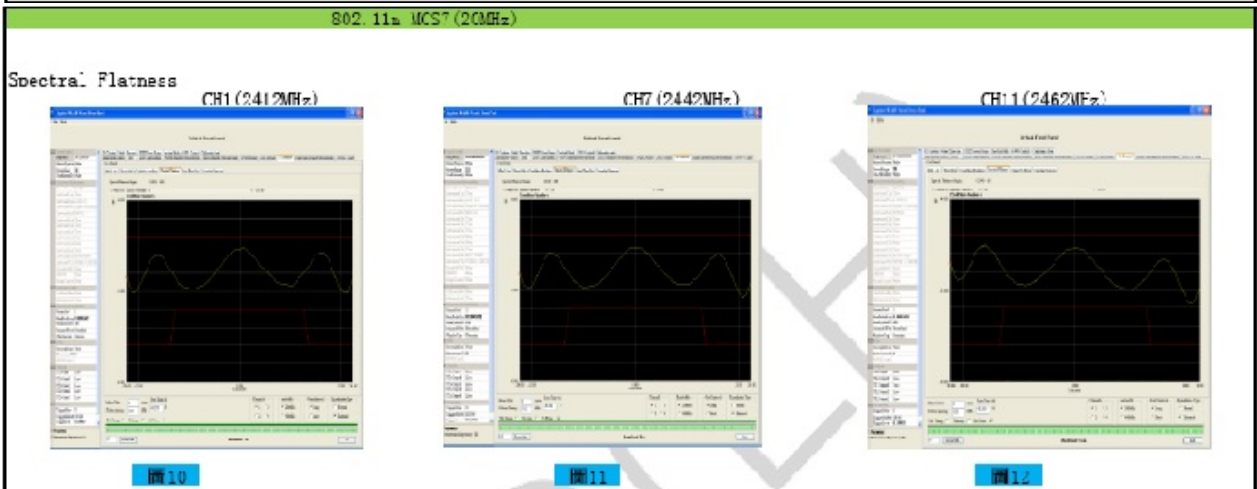
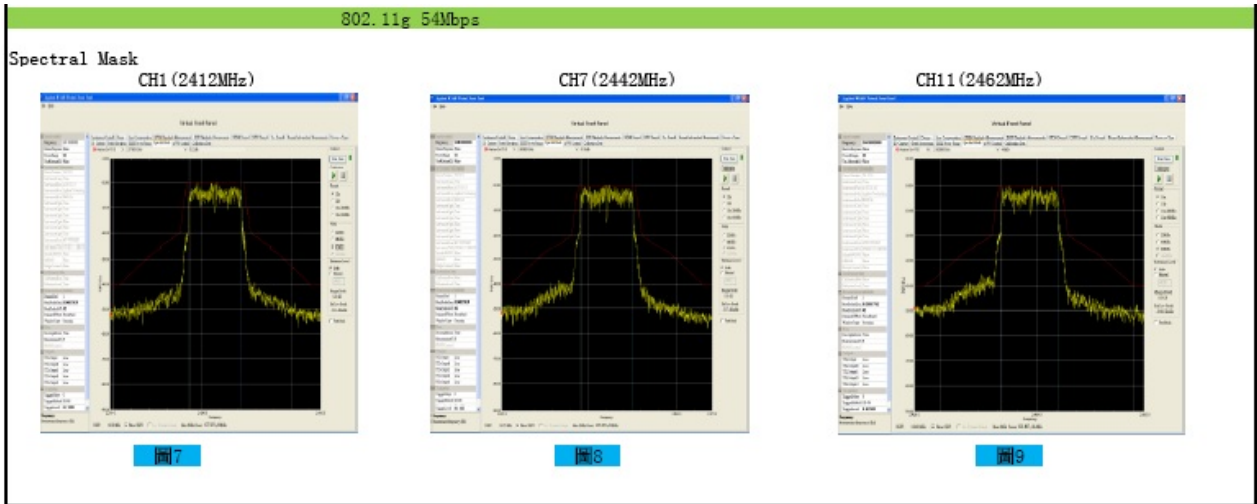

802.11a(5.15-5.25GHz,5.47-5.725GHz)	
ETSI TX average output power	≤20dBm
FCC TX peak effective power	<24dBm (250 mW or 11 dBm + 10 log B , where B
TX spectral flatness	± 1~± 18 ± 4 dB ± 17~± 26 +4/-6dB
IEEE Transmit center frequency tolerance	± 20 ppm
IEEE Transmit spectrum mask	Defined limit mask
IEEE Transmit power-on and power-down ramp	\
IEEE Modulation accuracy (EVM)	<5.6%(-25dB) for 54Mbit/s
IEEE PER search sensitivity	FER < 10% for -85dBm input, 54Mbit/s
IEEE Maximum input level	FER < 10% for -30dBm input, 54Mbit/s

Bluetooth Measurement Report

Date & Time: Wednesday, May 11, 2016 上午 09:07:40
 Operator: noname
 CBTgo Version: 2.3.0
 CBT Ident: Rohde&Schwarz, CBT-1153.9000.35,100500, CBT V5.20
 Options: 0, CBT-B55, K55, K53, FMR6, Intel Celeron Mobil, 256 MB, DIG FPGA RF FPGA
 Sequence: MOTO TEST ALL
 Shortcut:

Test Name and Condition Lower Limit Upper Limit Measured Value Unit P/F

Hopping Scheme Europe/USA, Tx Level: -40.0 dBm, Attenuation (In/Out): 1.2/1.2 dB, Auto ranging

Device Page Address: 983B16000000 (Inquire), Page Scan Repition Mode: R2

BD Adresse (CBT): 123456123456

Name: BCM4343A0 26, LMP Version: unassigned (7), Company ID: Broadcom Corporation, Version: 8482, BD Address: 983B16000000

Connection to Device: Passed

Hopping Scheme: RX/TX single frequency, Test Mode: Loopback, Tx Level: -40.0 dBm

10 Bursts, Packet Type: DH5, Power Class: Class 1, Automatic Level Control: Off

Channel: 0

Average Power	0	20	7.329401 dBm	Passed
Peak Power		23	8.095163 dBm	Passed

Channel: 39

Average Power	0	20	6.579996 dBm	Passed
Peak Power		23	7.486581 dBm	Passed

Channel: 78

Average Power	0	20	5.648904 dBm	Passed
Peak Power		23	6.712961 dBm	Passed

Hopping Scheme: RX/TX single frequency, Test Mode: TX Test, Tx Level: -40.0 dBm

10 Bursts, Packet Type: DH1, Power Class: Class 1, Automatic Level Control: Off

Channel: 0

Average Power 0 20 7.329401 dBm Passed
 Peak Power 23 8.095163 dBm Passed
 Channel: 39

Average Power 0 20 6.579996 dBm Passed
 Peak Power 23 7.486581 dBm Passed
 Channel: 78

Average Power 0 20 5.648904 dBm Passed
 Peak Power 23 6.712961 dBm Passed
 Hopping Scheme: RX/TX single frequency, Test Mode: TX Test, Tx Level: -40.0 dBm

10 Bursts, Packet Type: DH1, Power Class: Class 1, Automatic Level Control: Off

Channel: 0

Power at Maximum 5.645956 dBm Passed
 Power Step Down 2 8 3.432846 dB Passed
 Power Step Down 2 8 5.08016 dB Passed
 Power Step Down 2 8 5.528458 dB Passed
 Power Step Down 2 8 5.519502 dB Passed
 Power Step Down 2 8 3.97908 dB Passed
 Power Step Down 2 8 4.1945 dB Passed
 Power Step Down 2 8 4.15556 dB Passed
 Power at Minimum 4 -26.24415 dBm Passed
 Power Step Up 2 8 4.14747 dB Passed
 Power Step Up 2 8 4.23522 dB Passed
 Power Step Up 2 8 3.93021 dB Passed
 Power Step Up 2 8 5.546313 dB Passed
 Power Step Up 2 8 5.525193 dB Passed
 Power Step Up 2 8 5.136111 dB Passed
 Power Step Up 2 8 3.375284 dB Passed
 Power at Maximum 5.651651 dBm Passed

Hopping Scheme: RX/TX single frequency, Packet Type: DH5, Length of Testsequence: 339, Testmode: TX Test

50 Bursts, Detection Level: -30.0 dB, Pattern: Static PRBS, Tx Level: -40.0 dBm

f (L) : Channel: 0 2400 2401.022 MHz Passed
 f (H) : Channel: 78 2483.5 2480.928 MHz Passed

Hopping Scheme: RX/TX single frequency, Packet Type: DH5, Length of Testsequence: 339, Testmode: TX Test

Power at Maximum 7.322977 dBm Passed
 Power Step Down 2 8 3.905518 dB Passed
 Power Step Down 2 8 3.9752105 dB Passed
 Power Step Down 2 8 4.7029265 dB Passed
 Power Step Down 2 8 5.200462 dB Passed
 Power Step Down 2 8 3.71664 dB Passed
 Power Step Down 2 8 3.95776 dB Passed
 Power Step Down 2 8 4.38052 dB Passed
 Power at Minimum 4 -22.51606 dBm Passed
 Power Step Up 2 8 4.37053 dB Passed
 Power Step Up 2 8 3.96541 dB Passed
 Power Step Up 2 8 3.72869 dB Passed
 Power Step Up 2 8 5.185518 dB Passed
 Power Step Up 2 8 4.6573488 dB Passed
 Power Step Up 2 8 4.0480192 dB Passed
 Power Step Up 2 8 3.856476 dB Passed

Power at Maximum			5.645956 dBm	Passed
Power Step Down	2	8	3.432846 dB	Passed
Power Step Down	2	8	5.08016 dB	Passed
Power Step Down	2	8	5.528458 dB	Passed
Power Step Down	2	8	5.519502 dB	Passed
Power Step Down	2	8	3.97908 dB	Passed
Power Step Down	2	8	4.1945 dB	Passed
Power Step Down	2	8	4.15556 dB	Passed
Power at Minimum		4	-26.24415 dBm	Passed
Power Step Up	2	8	4.14747 dB	Passed
Power Step Up	2	8	4.23522 dB	Passed
Power Step Up	2	8	3.93021 dB	Passed
Power Step Up	2	8	5.546313 dB	Passed
Power Step Up	2	8	5.525193 dB	Passed
Power Step Up	2	8	5.136111 dB	Passed
Power Step Up	2	8	3.375284 dB	Passed
Power at Maximum			5.651651 dBm	Passed

Hopping Scheme: RX/TX single frequency, Packet Type: DH5, Length of Testsequence: 339, Testmode: TX Test

50 Bursts, Detection Level: -30.0 dB, Pattern: Static PRBS, Tx Level: -40.0 dBm

f (L) : Channel: 0	2400		2401.022 MHz	Passed
f (H) : Channel: 78		2483.5	2480.928 MHz	Passed

Hopping Scheme: RX/TX single frequency, Packet Type: DH5, Length of Testsequence: 339, Testmode: TX Test

50 Bursts, Detection Level: -30.0 dB, Pattern: Static PRBS, Tx Level: -40.0 dBm

f (L) : Channel: 0	2400		2401.022 MHz	Passed
f (H) : Channel: 78		2483.5	2480.928 MHz	Passed

Hopping Scheme: RX/TX single frequency, Packet Type: DH5, Length of Testsequence: 339, Testmode: TX Test

Sweeps: 10, Detection Level: -20.0 dB, Pattern: Static PRBS, Tx Level: -40.0 dBm

Channel: 0

f (L) :			-427.554 kHz	Passed
f (H) :			494.745 kHz	Passed
f (H) - f (L) : (Emission Peak: 1.3 dBm)		1000	922.299 kHz	Passed

Channel: 39

f (L) :			-428.054 kHz	Passed
f (H) :			493.432 kHz	Passed
f (H) - f (L) : (Emission Peak: 0.7 dBm)		1000	921.486 kHz	Passed

Channel: 78

f (L) :			-429.369 kHz	Passed
f (H) :			491.691 kHz	Passed
f (H) - f (L) : (Emission Peak: -0.1 dBm)		1500	921.06 kHz	Passed

Hopping Scheme: RX/TX single frequency, Packet Type: DH1, Length of Testsequence: 27, Testmode: Loopback

10 Sweeps, SweepTime: -842150451, Pattern: Static PRBS, Tx Level: -40.0 dBm

Channel: 3, Exceptions: 0

ACPower: -3	-40		-53.86548 dBm	Passed
ACPower: -2	-20		-50.84141 dBm	Passed
ACPower: -1			-19.32056 dBm	Passed
ACPower: Center			7.1242 dBm	Passed
ACPower: +1			-17.85056 dBm	Passed
ACPower: +2	-20		-51.20884 dBm	Passed
ACPower: +3	-40		-55.95457 dBm	Passed

Channel: 39, Exceptions: 0

f (L) : -429.369 kHz Passed
 f (H) : 491.691 kHz Passed
 f (H) - f (L) : (Emission Peak: -0.1 dBm) 1500 921.06 kHz Passed

Hopping Scheme: RX/TX single frequency, Packet Type: DH1, Length of Testsequence: 27, Testmode: Loopback

10 Sweeps, SweepTime: -842150451, Pattern: Static PRBS, Tx Level: -40.0 dBm

Channel: 3, Exceptions: 0

ACPower: -3 -40 -53.86548 dBm Passed
 ACPower: -2 -20 -50.84141 dBm Passed
 ACPower: -1 -19.32056 dBm Passed
 ACPower: Center 7.1242 dBm Passed
 ACPower: +1 -17.85056 dBm Passed
 ACPower: +2 -20 -51.20884 dBm Passed
 ACPower: +3 -40 -55.95457 dBm Passed

Channel: 39, Exceptions: 0

ACPower: -3 -40 -54.75568 dBm Passed
 ACPower: -2 -20 -50.28235 dBm Passed
 ACPower: -1 -19.82206 dBm Passed
 ACPower: Center 6.439294 dBm Passed
 ACPower: +1 -18.41843 dBm Passed
 ACPower: +2 -20 -50.38972 dBm Passed
 ACPower: +3 -40 -56.27863 dBm Passed

Channel: 75, Exceptions: 0

ACPower: -3 -40 -54.82834 dBm Passed
 ACPower: -2 -20 -49.94141 dBm Passed
 ACPower: -1 -20.30436 dBm Passed
 ACPower: Center 5.810083 dBm Passed
 ACPower: +1 -19.08701 dBm Passed
 ACPower: +2 -20 -50.05979 dBm Passed
 ACPower: +3 -40 -56.32017 dBm Passed

Hopping Scheme: RX/TX single frequency, Packet Type: DH5, Length of Testsequence: 339, Testmode: TX Test

20 Bursts, Tx Level: -40.0 dBm

Channel: 0

Delta F1 Avg 140 175 158.4619 kHz Passed
 Delta F2 Max Threshold: 115.0 kHz 99.9 100 % Passed
 Delta F2 Avg / Delta F1 Avg 0.8 0.99050308 Passed

Channel: 39

Delta F1 Avg 140 175 158.1462 kHz Passed
 Delta F2 Max Threshold: 115.0 kHz 99.9 100 % Passed
 Delta F2 Avg / Delta F1 Avg 0.8 0.980648919 Passed

Channel: 78

Delta F1 Avg 140 175 157.6175 kHz Passed
 Delta F2 Max Threshold: 115.0 kHz 99.9 100 % Passed
 Delta F2 Avg / Delta F1 Avg 0.8 0.998239409 Passed

Hopping Scheme: Europe/USA, Testmode: TX Test, Tx Level: -40.0 dBm

20 Bursts, Packet Type: DH1

Channel: 0

Max. Drift (DH1)	-25	25	-6.983551 kHz	Passed
Max. Drift (DH3)	-40	40	-6.90387 kHz	Passed
Max. Drift (DH5)	-40	40	-5.801483 kHz	Passed
Max. Drift Rate (DH1) (/ 50 us)	-20	20	3.555298 kHz	Passed
Max. Drift Rate (DH3) (/ 50 us)	-20	20	-4.039001 kHz	Passed
Max. Drift Rate (DH5) (/ 50 us)	-20	20	-4.327393 kHz	Passed

Channel: 78

Max. Drift (DH1)	-25	25	4.784485 kHz	Passed
Max. Drift (DH3)	-40	40	-6.512329 kHz	Passed
Max. Drift (DH5)	-40	40	5.836792 kHz	Passed
Max. Drift Rate (DH1) (/ 50 us)	-20	20	3.782654 kHz	Passed
Max. Drift Rate (DH3) (/ 50 us)	-20	20	4.069519 kHz	Passed
Max. Drift Rate (DH5) (/ 50 us)	-20	20	-4.489136 kHz	Passed

Hopping Scheme: RX/TX single frequency, Testmode: TX Test, Tx Level: -40.0 dBm, 20 Bursts

Channel: 0

Power DPSK - Power GFSK 2-DH5	-4	1	0.1987305 dB	Passed
Power GFSK 2-DH5			4.241266 dBm	Passed
Power DPSK 2-DH5			4.439996 dBm	Passed
Power DPSK - Power GFSK 3-DH5	-4	1	0.187088 dB	Passed
Power GFSK 3-DH5			4.247858 dBm	Passed
Power DPSK 3-DH5			4.434946 dBm	Passed

Channel: 39

Power DPSK - Power GFSK 2-DH5	-4	1	0.09233093 dB	Passed
Power GFSK 2-DH5			3.946466 dBm	Passed
Power DPSK 2-DH5			4.038797 dBm	Passed
Power DPSK - Power GFSK 3-DH5	-4	1	0.07347107 dB	Passed
Power GFSK 3-DH5			3.958704 dBm	Passed
Power DPSK 3-DH5			4.032175 dBm	Passed

Channel: 78

Power DPSK - Power GFSK 2-DH5	-4	1	-0.08599854 dB	Passed
Power GFSK 2-DH5			3.684534 dBm	Passed
Power DPSK 2-DH5			3.598535 dBm	Passed

Power DPSK - Power GFSK 3-DH5	-4	1	-0.09552002 dB	Passed
Power GFSK 3-DH5			3.683191 dBm	Passed
Power DPSK 3-DH5			3.587671 dBm	Passed

Hopping Scheme: RX/TX single frequency, Testmode: TX Test, Tx Level: -40.0 dBm

10 Bursts

Channel: 0

omega i 2-DH5	-75	75	23.58649 kHz	Passed
omega i + omega o 2-DH5	-75	75	23.71472 kHz	Passed
omega o 2-DH5	-10	10	-0.6047363 kHz	Passed
DEVM RMS 2-DH5		20	7.581162 %	Passed
DEVM Peak 2-DH5		35	15.45762 %	Passed
DEVM 99% 2-DH5, Threshold: 0.30	99		99.99999 %	Passed
omega i 3-DH5	-75	75	23.43393 kHz	Passed
omega i + omega o 3-DH5	-75	75	23.6427 kHz	Passed
omega o 3-DH5	-10	10	-0.2941589 kHz	Passed
DEVM RMS 3-DH5		13	6.182742 %	Passed
DEVM Peak 3-DH5		25	14.19492 %	Passed
DEVM 99% 3-DH5, Threshold: 0.20	99		99.99999 %	Passed

Channel: 39

omega i 2-DH5	-75	75	21.9415 kHz	Passed
omega i + omega o 2-DH5	-75	75	22.31894 kHz	Passed
omega o 2-DH5	-10	10	-0.2421265 kHz	Passed
DEVM RMS 2-DH5		20	8.290672 %	Passed
DEVM Peak 2-DH5		35	19.49764 %	Passed
DEVM 99% 2-DH5, Threshold: 0.30	99		99.99999 %	Passed
omega i 3-DH5	-75	75	21.672 kHz	Passed
omega i + omega o 3-DH5	-75	75	22.32205 kHz	Passed
omega o 3-DH5	-10	10	0.1386719 kHz	Passed
DEVM RMS 3-DH5		13	6.898856 %	Passed
DEVM Peak 3-DH5		25	17.53731 %	Passed
DEVM 99% 3-DH5, Threshold: 0.20	99		99.99999 %	Passed

Channel: 78

Power DPSK - Power GFSK 3-DH5	-4	1	-0.09552002 dB	Passed
Power GFSK 3-DH5			3.683191 dBm	Passed
Power DPSK 3-DH5			3.587671 dBm	Passed

Hopping Scheme: RX/TX single frequency, Testmode: TX Test, Tx Level: -40.0 dBm

10 Bursts

Channel: 0

omega i 2-DH5	-75	75	23.58649 kHz	Passed
omega i + omega o 2-DH5	-75	75	23.71472 kHz	Passed
omega o 2-DH5	-10	10	-0.6047363 kHz	Passed
DEVM RMS 2-DH5		20	7.581162 %	Passed
DEVM Peak 2-DH5		35	15.45762 %	Passed
DEVM 99% 2-DH5, Threshold: 0.30	99		99.99999 %	Passed
omega i 3-DH5	-75	75	23.43393 kHz	Passed
omega i + omega o 3-DH5	-75	75	23.6427 kHz	Passed
omega o 3-DH5	-10	10	-0.2941589 kHz	Passed
DEVM RMS 3-DH5		13	6.182742 %	Passed
DEVM Peak 3-DH5		25	14.19492 %	Passed
DEVM 99% 3-DH5, Threshold: 0.20	99		99.99999 %	Passed

Channel: 39

omega i 2-DH5	-75	75	21.9415 kHz	Passed
omega i + omega o 2-DH5	-75	75	22.31894 kHz	Passed
omega o 2-DH5	-10	10	-0.2421265 kHz	Passed
DEVM RMS 2-DH5		20	8.290672 %	Passed
DEVM Peak 2-DH5		35	19.49764 %	Passed
DEVM 99% 2-DH5, Threshold: 0.30	99		99.99999 %	Passed
omega i 3-DH5	-75	75	21.672 kHz	Passed
omega i + omega o 3-DH5	-75	75	22.32205 kHz	Passed
omega o 3-DH5	-10	10	0.1386719 kHz	Passed
DEVM RMS 3-DH5		13	6.898856 %	Passed
DEVM Peak 3-DH5		25	17.53731 %	Passed
DEVM 99% 3-DH5, Threshold: 0.20	99		99.99999 %	Passed

Channel: 78

omega i 2-DH5	-75	75	20.59146 kHz	Passed
omega i + omega o 2-DH5	-75	75	20.85767 kHz	Passed
omega o 2-DH5	-10	10	-0.2815552 kHz	Passed
DEVM RMS 2-DH5		20	9.10219 %	Passed
DEVM Peak 2-DH5		35	20.82286 %	Passed
DEVM 99% 2-DH5, Threshold: 0.30	99		99.99999 %	Passed
omega i 3-DH5	-75	75	20.54321 kHz	Passed
omega i + omega o 3-DH5	-75	75	20.86115 kHz	Passed
omega o 3-DH5	-10	10	-0.3264771 kHz	Passed
DEVM RMS 3-DH5		13	7.203829 %	Passed
DEVM Peak 3-DH5		25	21.09071 %	Passed
DEVM 99% 3-DH5, Threshold: 0.20	99		99.99622 %	Passed

Hopping Scheme: RX/TX single frequency, Tx Level: -40.0 dBm

10 Bursts

Channel: 0

Packets with 0 errors 2-DH1	99		100 %	Passed
Packets with 0 errors 3-DH1	99		100 %	Passed

Hopping Scheme: RX/TX single frequency, Packet Type: 2-DH5, Length of Testsequence: 679, Testmode: TX Test

10 Sweeps, Pattern: Static PRBS, Tx Level: -40.0 dBm

ACPower: -3 -40 -46.47596 dBm Passed
 ACPower: -2 -20 -28.65082 dBm Passed
 ACPower: -1, P tx-26 dB -24.616492 -29.01801 dBm Passed
 ACPower: Center, Ptxref 1.383508 dBm Passed
 ACPower: +1, P tx-26 dB -24.616492 -27.34165 dBm Passed
 ACPower: +2 -20 -25.86417 dBm Passed
 ACPower: +3 -40 -44.32569 dBm Passed
 Channel: 75, Ptx_Ref: 1.39 dBm, Exceptions: 0

ACPower: -3 -40 -45.21119 dBm Passed
 ACPower: -2 -20 -26.9929 dBm Passed
 ACPower: -1, P tx-26 dB -24.605627 -26.78712 dBm Passed
 ACPower: Center, Ptxref 1.394373 dBm Passed
 ACPower: +1, P tx-26 dB -24.605627 -25.60111 dBm Passed
 ACPower: +2 -20 -24.81315 dBm Passed
 ACPower: +3 -40 -42.42606 dBm Passed

Hop Scheme: RX/TX single frequency, Packet Type: DH1, Pattern: SPRS, Whitening: Off
 Tx Level: -70.0 dBm, Packets: 7408, Loopback Delay Off, Dirty Transmitter: Specification Table

BER: @ Channel: RX: 0, TX: 78, *1E-6 1000 0 Passed
 BER: @ Channel: RX: 39, TX: 0, *1E-6 1000 0 Passed
 BER: @ Channel: RX: 78, TX: 0, *1E-6 1000 0 Passed

Hop Scheme: RX/TX single frequency, Packet Type: DH5, Pattern: SPRS, Whitening: Off
 Tx Level: -70.0 dBm, Packets: 590, Loopback Delay Off, Dirty Transmitter: Specification Table

BER: @ Channel: RX: 0, TX: 78, *1E-6 1000 0 Passed
 BER: @ Channel: RX: 39, TX: 0, *1E-6 1000 0 Passed
 BER: @ Channel: RX: 78, TX: 0, *1E-6 1000 0 Passed

Hop Scheme: RX/TX single frequency, Packet Type: DH1, Pattern: SPRS, Whitening: Off
 Tx Level: -20.0 dBm, Packets: 7408, Loopback Delay Off, Dirty Transmitter: Off

BER: @ Channel: RX: 0, TX: 78, *1E-6 1000 0 Passed
 BER: @ Channel: RX: 39, TX: 0, *1E-6 1000 0 Passed
 BER: @ Channel: RX: 78, TX: 0, *1E-6 1000 0 Passed

Hop Scheme: RX/TX single frequency, Packet Type: 2-DH5, Pattern: SPRS, Whitening: On
 Tx Level: -70.0 dBm, Packets: 2946, Packets (early exit): 295, Loopback Delay Off, Dirty Transmitter: Specification Table

Test: Sensitivity, Bit 16002672, Bit (early exit): 1602440
 BER: @ Channel: RX: 0, TX: 78, Early exit, * 1f 70 0 Passed
 BER: @ Channel: RX: 39, TX: 0, Early exit, * 1f 70 0 Passed
 BER: @ Channel: RX: 78, TX: 0, Early exit, * 1f 70 0 Passed

Hop Scheme: RX/TX single frequency, Packet Type: 3-DH5, Pattern: SPRS, Whitening: On
 Tx Level: -70.0 dBm, Packets: 1959, Packets (early exit): 196, Loopback Delay Off, Dirty Transmitter: Specification Table
 Test: Sensitivity, Bit 16001112, Bit (early exit): 1600928

BER: @ Channel: RX: 0, TX: 78, Early exit, * 1f 70 0 Passed
 BER: @ Channel: RX: 39, TX: 0, Early exit, * 1f 70 0 Passed
 BER: @ Channel: RX: 78, TX: 0, Early exit, * 1f 70 0 Passed

Hop Scheme: RX/TX single frequency, Packet Type: 2-DH5, Pattern: SPRS, Whitening: On
 Tx Level: -60.0 dBm, Packets: 29456, Packets (early exit): 1473, Loopback Delay Off, Dirty Transmitter: Off
 Test: Floor Performance, Bit 160004992, Bit (early exit): 8001336

BER: @ Channel: RX: 0, TX: 78, Early exit, * 1f 7 0 Passed
 BER: @ Channel: RX: 39, TX: 0, Early exit, * 1f 7 0.2499583 Passed
 BER: @ Channel: RX: 78, TX: 0, Early exit, * 1f 7 0 Passed

Hop Scheme: RX/TX single frequency, Packet Type: 3-DH5, Pattern: SPRS, Whitening: On
 Tx Level: -60.0 dBm, Packets: 19589, Packets (early exit): 980, Loopback Delay Off, Dirty Transmitter: Off
 Test: Floor Performance, Bit 160002952, Bit (early exit): 8004640

BER: @ Channel: RX: 0, TX: 78, Early exit, * 1f 7 0 Passed
 BER: @ Channel: RX: 39, TX: 0, Early exit, * 1f 7 0 Passed
 BER: @ Channel: RX: 78, TX: 0, Early exit, * 1f 7 0 Passed

Hop Scheme: RX/TX single frequency, Packet Type: 2-DH5, Pattern: SPRS, Whitening: On

Tx Level: -70.0 dBm, Packets: 7408, Loopback Delay Off, Dirty Transmitter: Specification Table

BER: @ Channel: RX: 0, TX: 78 ,	*1E-6	1000	0	Passed
BER: @ Channel: RX: 39, TX: 0 ,	*1E-6	1000	0	Passed
BER: @ Channel: RX: 78, TX: 0 ,	*1E-6	1000	0	Passed

Hop Scheme: RX/TX single frequency, Packet Type: DH5, Pattern: SPRS, Whitening: Off

Tx Level: -70.0 dBm, Packets: 590, Loopback Delay Off, Dirty Transmitter: Specification Table

BER: @ Channel: RX: 0, TX: 78 ,	*1E-6	1000	0	Passed
BER: @ Channel: RX: 39, TX: 0 ,	*1E-6	1000	0	Passed
BER: @ Channel: RX: 78, TX: 0 ,	*1E-6	1000	0	Passed

Hop Scheme: RX/TX single frequency, Packet Type: DH1, Pattern: SPRS, Whitening: Off

Tx Level: -20.0 dBm, Packets: 7408, Loopback Delay Off, Dirty Transmitter: Off

BER: @ Channel: RX: 0, TX: 78 ,	*1E-6	1000	0	Passed
BER: @ Channel: RX: 39, TX: 0 ,	*1E-6	1000	0	Passed
BER: @ Channel: RX: 78, TX: 0 ,	*1E-6	1000	0	Passed

Hop Scheme: RX/TX single frequency, Packet Type: 2-DH5, Pattern: SPRS, Whitening: On

Tx Level: -70.0 dBm, Packets: 2946, Packets (early exit): 295, Loopback Delay Off, Dirty Transmitter: Specification Table

Test: Sensitivity, Bit 16002672, Bit (early exit): 1602440

BER: @ Channel: RX: 0, TX: 78, Early exit,	* 1f	70	0	Passed
BER: @ Channel: RX: 39, TX: 0, Early exit,	* 1f	70	0	Passed
BER: @ Channel: RX: 78, TX: 0, Early exit,	* 1f	70	0	Passed

Hop Scheme: RX/TX single frequency, Packet Type: 3-DH5, Pattern: SPRS, Whitening: On

Tx Level: -70.0 dBm, Packets: 1959, Packets (early exit): 196, Loopback Delay Off, Dirty Transmitter: Specification Table

Test: Sensitivity, Bit 16001112, Bit (early exit): 1600928

BER: @ Channel: RX: 0, TX: 78, Early exit,	* 1f	70	0	Passed
BER: @ Channel: RX: 39, TX: 0, Early exit,	* 1f	70	0	Passed
BER: @ Channel: RX: 78, TX: 0, Early exit,	* 1f	70	0	Passed

Hop Scheme: RX/TX single frequency, Packet Type: 2-DH5, Pattern: SPRS, Whitening: On

Tx Level: -60.0 dBm, Packets: 29456, Packets (early exit): 1473, Loopback Delay Off, Dirty Transmitter: Off

Test: Floor Performance, Bit 160004992, Bit (early exit): 8001336

BER: @ Channel: RX: 0, TX: 78, Early exit,	* 1f	7	0	Passed
BER: @ Channel: RX: 39, TX: 0, Early exit,	* 1f	7	0.2499583	Passed
BER: @ Channel: RX: 78, TX: 0, Early exit,	* 1f	7	0	Passed

Hop Scheme: RX/TX single frequency, Packet Type: 3-DH5, Pattern: SPRS, Whitening: On

Tx Level: -60.0 dBm, Packets: 19589, Packets (early exit): 980, Loopback Delay Off, Dirty Transmitter: Off

Test: Floor Performance, Bit 160002952, Bit (early exit): 8004640

BER: @ Channel: RX: 0, TX: 78, Early exit,	* 1f	7	0	Passed
BER: @ Channel: RX: 39, TX: 0, Early exit,	* 1f	7	0	Passed
BER: @ Channel: RX: 78, TX: 0, Early exit,	* 1f	7	0	Passed

Hop Scheme: RX/TX single frequency, Packet Type: 2-DH5, Pattern: SPRS, Whitening: On

BPI-M2+ Samsung DDR validation report

DDR3 Signal Measurement

181 Tests Planned
 181 Tests Attempted
 181 Tests Passed
 0 Tests Blocked
 0 Tests Failed

DUT Information

Model name	BananaPI BPI-M2+
OS	Andriod
Memory Chip	Samsung

Test Equipments

1. TEK TDS6804B Oscilloscope: Bandwidth-8GHz, Sample Rate-20.0GS/s.
2. Probe : Tektronix P7240(4GHz)*2
Tektronix P7330(3.5GHz)*2
3. Software: Tektronix TDSJIT3 Advanced Jitter Analysis Version: 3.0.2 build 4

Test Condition

Measurement Voltage Level(Please fill the value of v voltage tested):

	DDR3-1333	Remark
VDDQ(V)	1.508	VDDQ+/-0.075
VREF(V)	0.755	

Test Procedure

1. Warm up and calibrate scope.
2. Check the test points both on source and destination
3. Connect the probes to the test points
4. Set proper trigger to capture wave forms
5. Capture the wave forms and measure all the parameters by following test plan

Reference Document

1. JESD79-3F.pdf

Block	Signal Name	Probe Location	VIH(ac) (V)	VIL(ac) (V)	Notes	Planned	Attempted	Passed	Blocked	Failed
	SCKP	DU1.J7	1.506	0.03		2	2	2	0	0
	SCKN	DU1.K7	1.461	0.063		2	2	2	0	0
	SPEC		>Vref+0.15	<Vref-0.15	Total	4	4	4	0	0

For differential clock slew rate for rising edges is measured from CK - CK = -200 mV to CK - CK = +200 mV (200mV to -200 mV for falling edge)

Block	Signal Name	Probe Location	VIH diff(ac) (V)	VIL diff(ac) (V)	I _{CH} (avg) (%CK)	I _{CL} (avg) (%CK)	Rising slew rate (V/ns)	Falling slew rate (V/ns)	Frequency (MHz)	TCK(avg) (ns)	Cycle to Cycle Jitter	VIX (mV)	Notes	Planned	Attempted	Passed	Blocked	Failed
	SCKP	DU1.J7	1.27	-1.28	0.4925	0.5075	8.205	6.308	672.06	1.488	53.333	733.5-819.65	Vref=0.755V	10	10	10	0	0
	SCKN	DU1.K7																
	SPEC		>2*(VIH(ac)-Vref)/2*(VIL(ac)-Vref)		47-53	47-53	>1	>1	TBD	<8	<160	<=150+Vref*0.18	Total	10	10	10	0	0

Block	Signal Name	Probe Location	VIH(ac) (V)	VIL(ac) (V)	RISE RINGBACK (V)	FALL RINGBACK (V)	OVERSHOOT (V)	UNDERSHOOT (V)	Positive Pulse Width (ns)	Setup Time (ns)	Hold Time (ns)	Setup Time Slew Rate (V/nS)	Hold Time Slew Rate (V/nS)	Notes	Planned	Attempted	Passed	Blocked	Failed
	SA7	DU1.R2	1.467	0.015	1.38	0.132	1.578	-0.2101	2.948	1.975	0.95	2.135	2.507		11	11	11	0	0
	SA10	DU1.L7	1.443	0.016	1.374	0.054	1.614	-0.1982	2.94	2.05	0.825	2.891	2.817		11	11	11	0	0
	SPEC		>Vref+0.15	<Vref-0.15	>Vref+0.100	<Vref-0.100	<1.975	>-0.4	0.62	>190ps+Δt	>40ps+Δt1	>0.4	>0.4	Total	22	22	22	0	0

Block	Signal Name	Probe Location	VIH(ac) (V)	VIL(ac) (V)	RISE RINGBACK (V)	FALL RINGBACK (V)	OVERSHOOT (V)	UNDERSHOOT (V)	Positive/Negative Pulse Width (ns)	Setup Time (ns)	Hold Time (ns)	Setup Time Slew Rate (V/nS)	Hold Time Slew Rate (V/nS)	Notes	Planned	Attempted	Passed	Blocked	Failed
	SCAS	DU1.K3	1.47	0.006	1.35	0.066	1.674	-0.1659	2.924	2	0.875	3.509	3.145		11	11	11	0	0
	SRAS	DU1.J3	1.479	0.039	1.35	0.066	1.663	-0.1895	2.939	1.975	0.9	2.870	3.654		11	11	11	0	0
	SCS0	DU1.L2	1.494	0.06	1.392	0.09	1.786	-0.198	1.461	0.58	0.79	2.867	3.355		11	11	11	0	0
	SWE	DU1.L3	1.479	-0.021	1.38	0.078	1.676	-0.1763	2.934	1.975	0.9	3.211	3.001		11	11	11	0	0
	SBA0	DU1.M2	1.479	-0.009	1.35	0.102	1.614	-0.1845	2.91	1.95	0.95	3.390	3.645		11	11	11	0	0
	SBA1	DU1.M8	1.371	-0.009	1.332	0.009	1.717	-0.1671	2.938	2	0.9	4.363	4.095		11	11	11	0	0
	SBA2	DU1.N8	1.551	-0.009	1.35	0.006	1.686	-0.126	2.948	1.9	0.925	3.080	3.802		11	11	11	0	0
	SPEC		>Vref+0.15	<Vref-0.15	>Vref+0.100	<Vref-0.100	<1.975	>-0.4	0.62	>190ps+Δt	>40ps+Δt1	>0.4	>0.4	Total	77	77	77	0	0

Block	Signal Name	Probe Location	VIH(ac) (V)	VIL(ac) (V)	RISE RINGBACK (V)	FALL RINGBACK (V)	OVERSHOOT (V)	UNDERSHOOT (V)	Positive Pulse Width (ns)	Setup Time (ns)	Hold Time (ns)	Setup Time Slew Rate (V/nS)	Hold Time Slew Rate (V/nS)	Notes	Planned	Attempted	Passed	Blocked	Failed
	SDQ2	DU1.F7	1.506	0.18	1.182	0.234	1.616	-0.07317	0.705	0.3872	0.2512	3.778	4.177		11	11	11	0	0
	SDQ8	DU1.D7	1.415	0.149	1.3129	0.298	1.501	0.01648	0.7451	0.3519	0.3404	2.935	3.622		11	11	11	0	0
	SPEC		>Vref+0.15	<Vref-0.15	>Vref+0.100	<Vref-0.100	<1.975	>-0.4	0.4	>30ps+Δt	>65ps+Δt1	>0.4	>0.4	Total	22	22	22	0	0

Block	Signal Name	Probe Location	VIH(ac) (V)	VIL(ac) (V)	RISE RINGBACK (V)	FALL RINGBACK (V)	OVERSHOOT (V)	UNDERSHOOT (V)	Notes	Planned	Attempted	Passed	Blocked	Failed
	SDQS0P	DU1.F3	1.467	-0.045	1.368	-0.006	1.581	-0.1624		6	6	6	0	0
	SDQS0N	DU1.G3	1.563	-0.086	1.56	0.162	1.89	-0.066		6	6	6	0	0
	SDQS1P	DU1.C7	1.506	0.042	1.38	0.056	1.529	-0.04608		6	6	6	0	0
	SDQS1N	DU1.B7	1.506	0.138	1.44	0.252	1.626	0.1005		6	6	6	0	0
	SPEC		>(VDD/2)+0.15	<(VDD/2)-0.15	>Vref+0.100	<Vref-0.100	<1.975	>-0.4	Total	24	24	24	0	0

Block	Signal Name	Probe Location	VIH diff(ac) (V)	VIL diff(ac) (V)	Input Rising Slew Rate (V/nS)	Input Falling Slew Rate (V/nS)	tdQS (nS)	tdQL (nS)	tdSS (nS)	tdSH (nS)	tRPRE (nS)	tWPRE (nS)	tdQSS (nS)	Notes	Planned	Attempted	Passed	Blocked	Failed
	SDQS0P	DU1.F3	0.995	-1.165	9.639	7.535	0.7063	0.7694	0.7242	0.7491	1.705	1.565	-0.03474		11	11	11	0	0
	SDQS0N	DU1.G3																	
	SDQS1P	DU1.C7	1.055	-1.145	8.45	8.735	0.6934	0.7665	0.7607	0.7283	1.75	1.565	-0.03316		11	11	11	0	0
	SDQS1N	DU1.B7																	
	SPEC		>2*(VIH(ac)-Vref)/2*(VIL(ac)-Vref)		>1	>1	45-0.95tCKav	45-0.95tCKav	>0.2tCK	>0.2tCK	>0.9tCK	>0.8tCK	0.25-0.28tCK	Total	22	22	22	0	0

- 1.
- 2.

| | | | | | | | | | | | | | | | | | | | | |

BPI-M2+ USB validation report

Test Case: USB Interface	
94	Tests Planned
94	Tests Attempted
73	Tests Passed
15	Tests Blocked
6	Tests Failed

DUT Information	
Model name	BananaPi
OS	Android

- Test Equipments**
1. Scope: Tektronix TDS7704B Digital Phosphor Oscilloscope(7GHz,20GS/s)
 2. Application Tool of Scope: USB2.0 Test Package Application (version: 3.6.0)
 3. Differential Probe: Tektronix P7330*1
 4. Single End Probe: Tektronix P7240*2
 5. Test Fixture: Tektronix TDSUSBF USB2.0 Compliance Test Fixture With Power Adapter
 6. DUT Test Software: USB High Speed Electrical Test Toolkit (version: 1[1].1.3.0)
 7. DMM: FLUKE 179 TRUE RMS MULTIMETER
 8. Full Speed Device: Angilent 128M U Disk
 9. Low Speed Device: Microsoft Mouse
 10. USB 1 Meter Cable: Belkin Pro Series USB 2.0 Cable (28AWG)*2

Test Tools
N/A

- Ref Documents**
1. USB2.0 Specifications, Rev 2.0-2000
 2. High-speed Electrical Test Toolkit (HSElecTestSetup.p20.DOC Revision 1.2)
 3. USB-IF Full and Low Speed Electrical and Interoperability Compliance Test Procedure Revision 1.3, February 2004
 4. TDSUSB2 help topics.Rev 1.3.1

第 1 頁

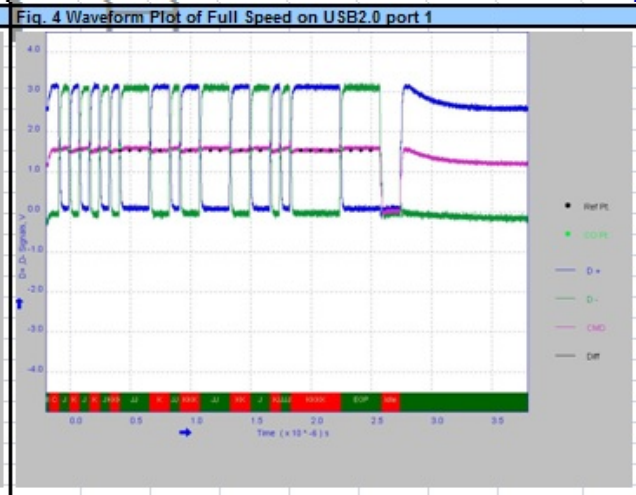
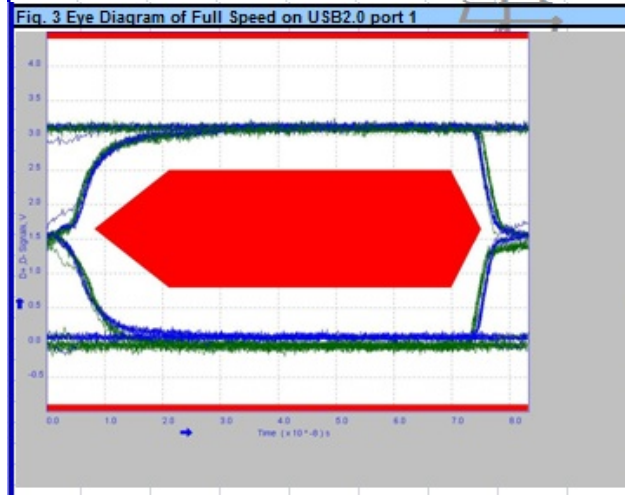
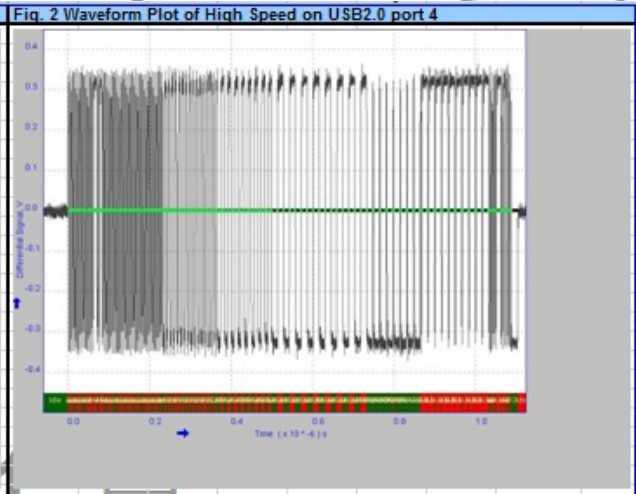
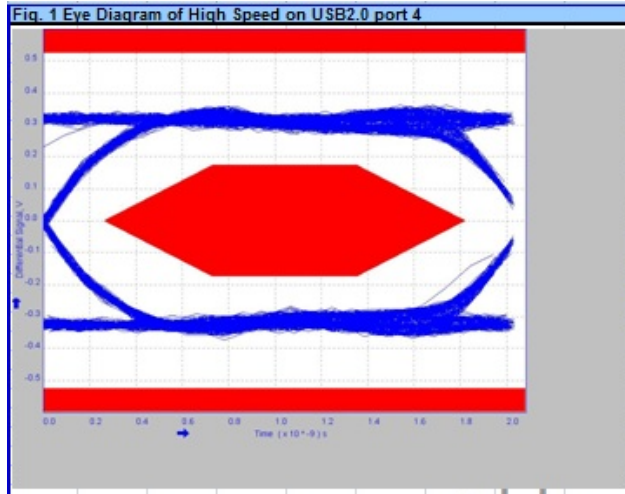

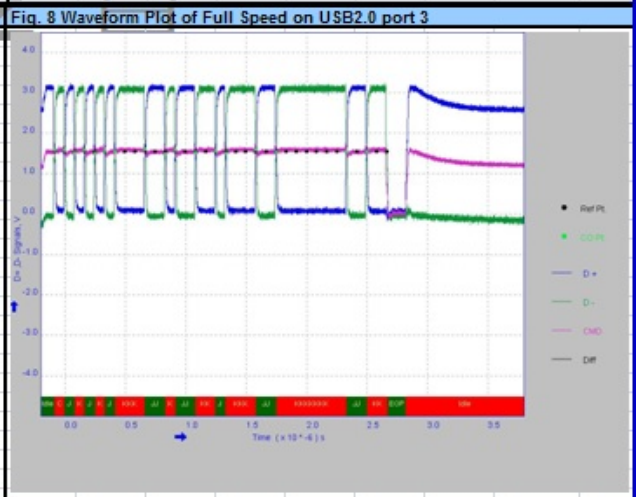
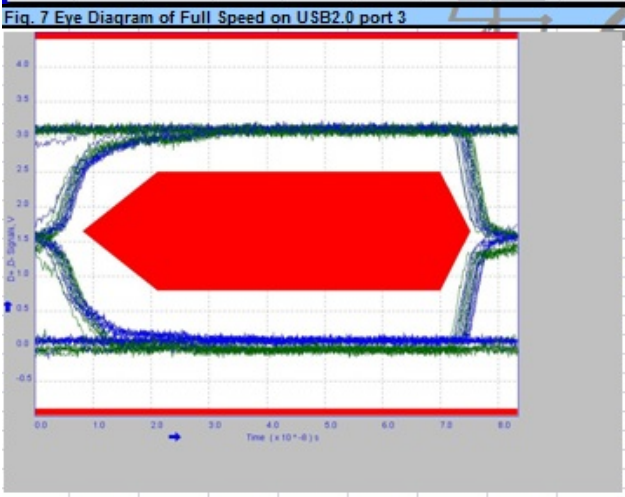
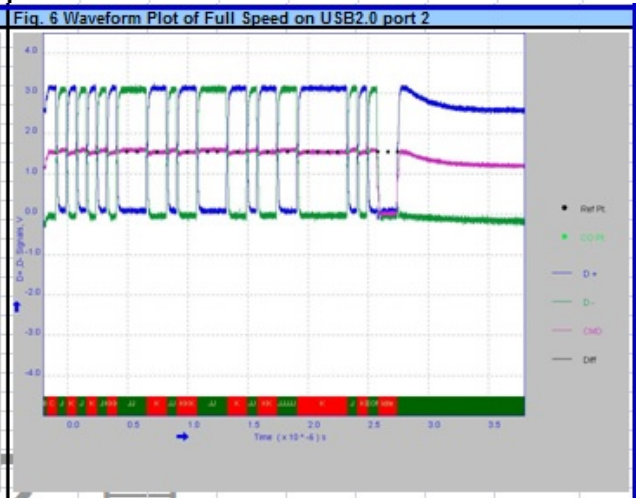
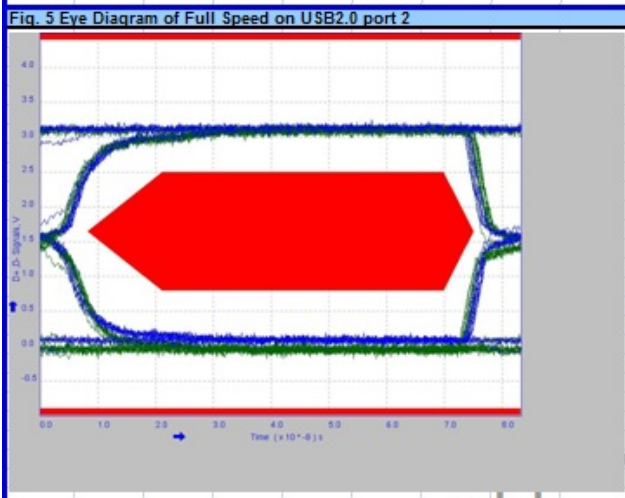
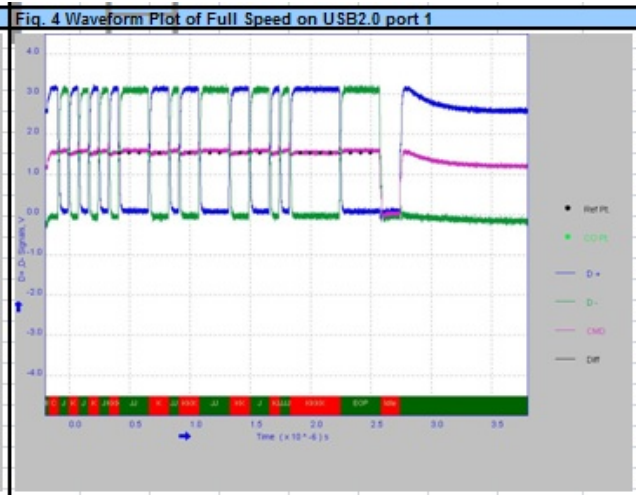
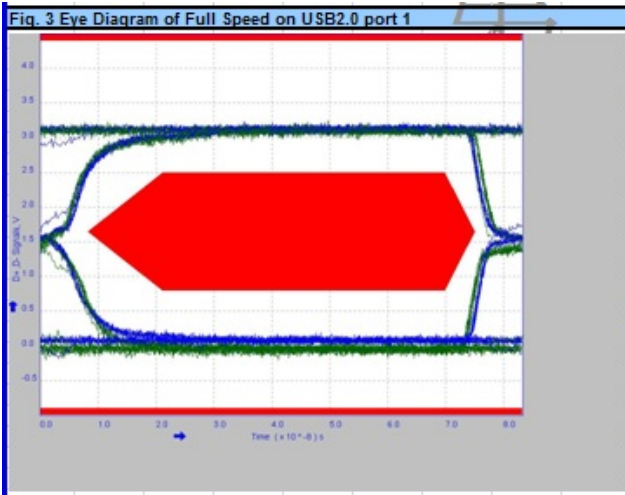

Fig. 9 Eye Diagram of Full Speed on USB2.0 port 4

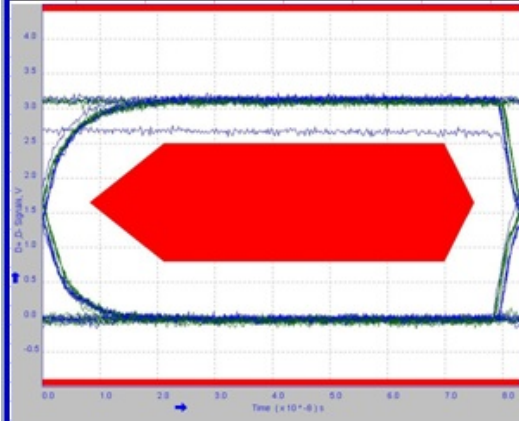

Fig. 10 Waveform Plot of Full Speed on USB2.0 port 4

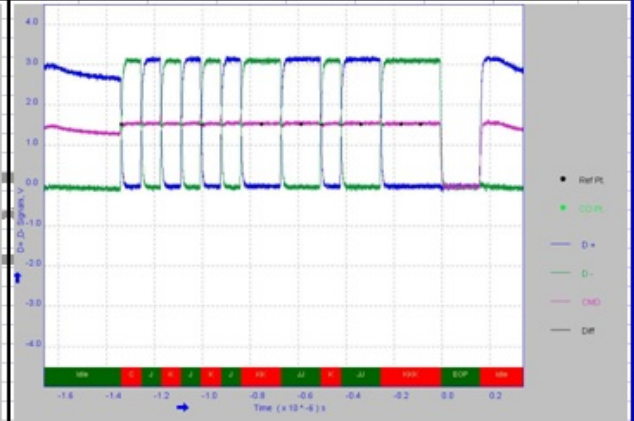

Fig. 11 Eye Diagram of Low Speed on USB2.0 port 1

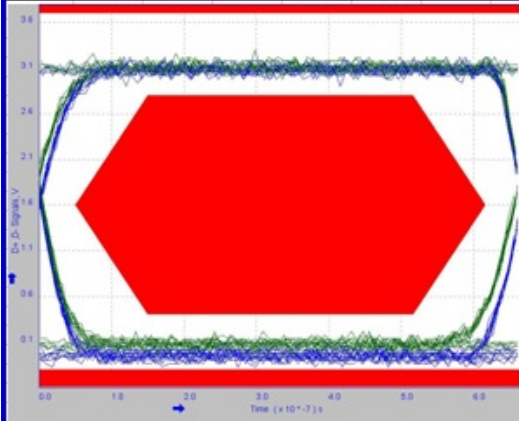

Fig. 12 Waveform Plot of Low Speed on USB2.0 port 1

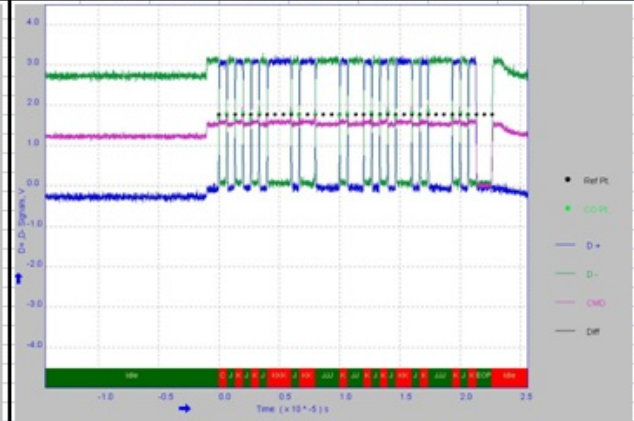

Fig. 13 Eye Diagram of Low Speed on USB2.0 port 2

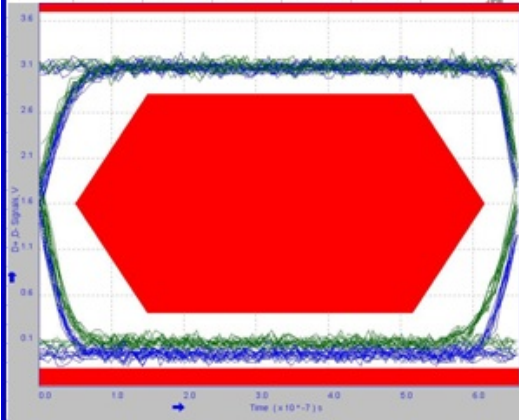
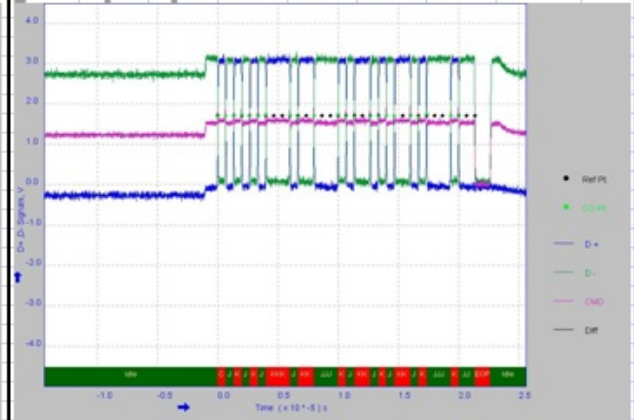
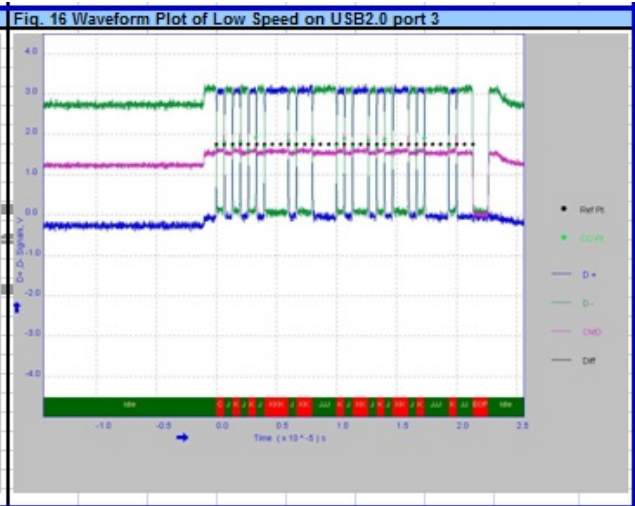
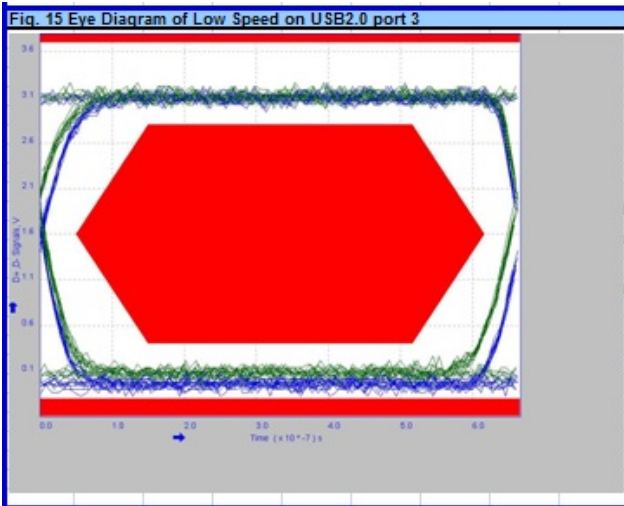

Fig. 14 Waveform Plot of Low Speed on USB2.0 port 2





BPI-M2+ Power validation report

Electronic Component & Module Engineering

Table of Contents

- 1. Test Summary 4**
- 2. System Configuration 5**
- 3. Electrical Performance Test 6**
 - 3.1 Output Ripple & Noise Test.....6
- 4. Signal Integrity Test 9**
 - 4.1 Power Timing & Sequence Test.....9

Electronic Component & Module Engineering

1. Test Summary

Table I.

Test Duration	2016/05/10 -- 2016/05/16	Project	Banana Pi
Model	Bpi M2 PLUS	REV.	V1.1
Product P/N	N/A	Product S/N	08014997
Equipment	Electronic Load, Oscilloscope		

Sample photo



**Table II.**

Item	Test Content	Test Quantity (pcs)	Test Result
1	Output Ripple&Noise Test	1	Reference
2	Power Timing & Sequence Test	1	Reference
Remark			

2. System Configuration

N/A

3. Electrical Performance Test

3.1 Output Ripple & Noise Test

3.1.1 Test Requirement

- Test Equipment: Oscilloscope
- Test Quantity: 1pcs

3.1.2 Test Condition

- Ambient Temperature: 23+/- 2°C

3.1.3 Reference Criteria

- N/A.

3.1.4 Test Result: Reference

Tested Power	Ripple&Noise(mV)	Result
AVCC	18.0	Reference
USB_PORT	39.2	Reference
USB-ID	19.6	Reference
V_OTG	12.8	Reference
VCC_RTC	14.0	Reference
VCC-1V2	67.2	Reference
VCC-3V3	11.2	Reference
VCC-DRAM	55.2	Reference
VDD-CPUS	7.2	Reference
VDD-CPUX	42.4	Reference
WIFI_VBAT	6.8	Reference

Electronic Component & Module Engineering

Test Curve Photo

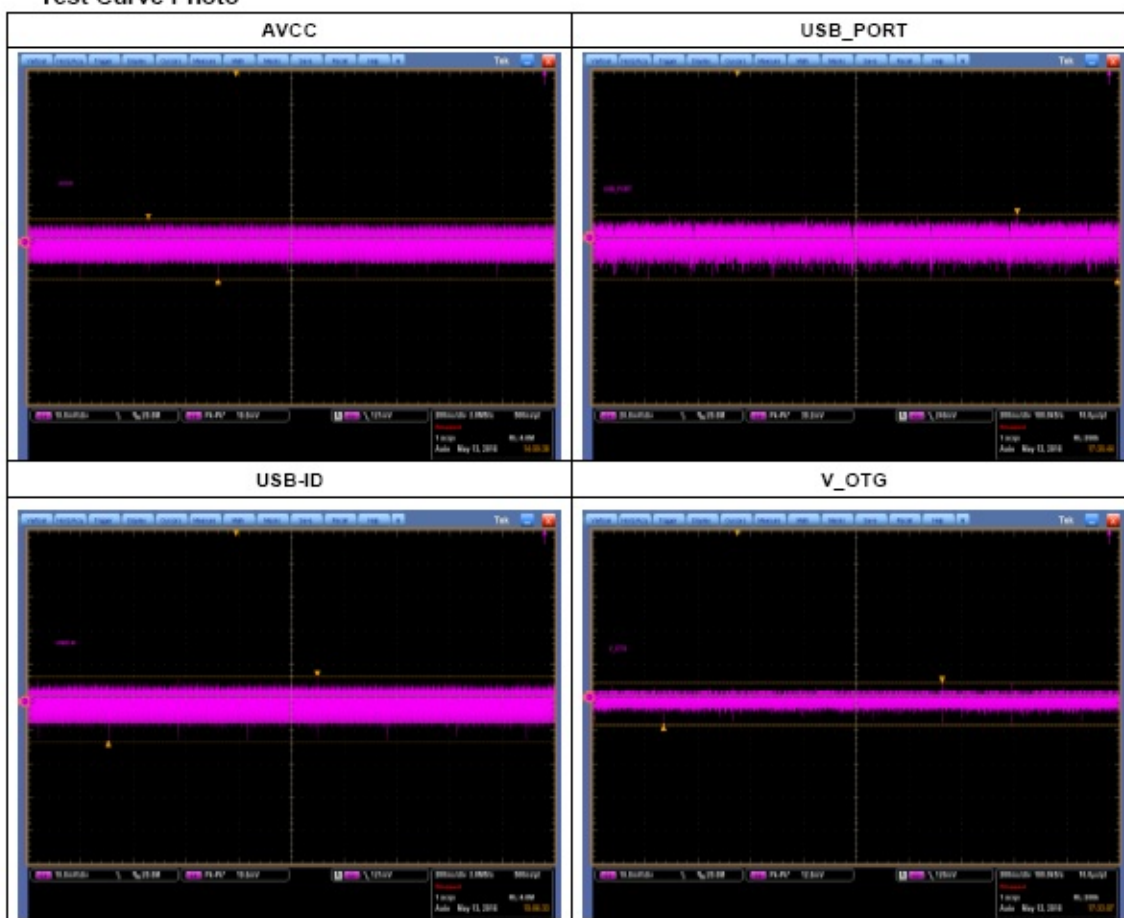

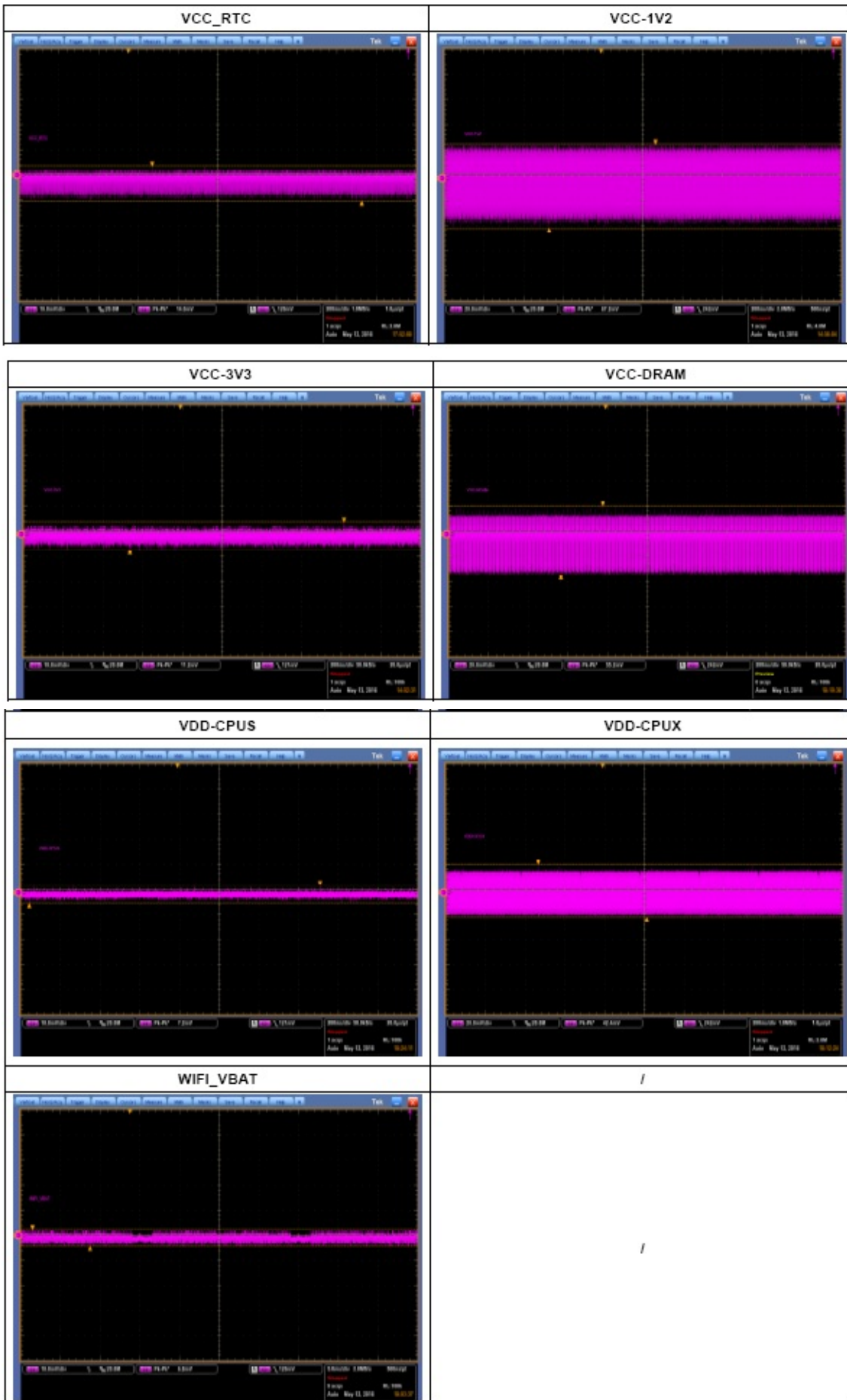

4. Signal Integrity Test

4.1 Power Timing & Sequence Test

4.1.1 Test Requirement

- Test Equipment: Oscilloscope
- Test Quantity: 1pcs

4.1.2 Test Condition

- Ambient Temperature: 23+/- 2°C

4.1.3 Reference Criteria

- N/A.

4.1.4 Test Result: Reference

Tested_Power	Turn on time(ms)	Hold up time(ms)	Result
V-DCIN & OTG	4240	5.31	Reference
V-DCIN & USB_PORT	5.31	6.67	Reference

Turn on time:



Hold up time:



BPI-M2+ CE,FCC RoHS Certification

BPI-M2+ CE Certification:

CERTIFICADO ◆ YARUITESTING ◆ ZERTIFIKAT ◆ CERTIFICATE



EC Declaration of Conformity

Based on the voluntary assessment of the product sample and technical file, we confirm that the above-mentioned product meets the requirements of the EC directive.
The following products have been tested by us with listed standards and found in compliance with the council Directive 1999/5/EC.

Certificate No.:	YRT201605255C
Applicant:	GUANGDONG BIPAI KEJI.CPA.,LTD
Address:	7th floor,RongYi Building, Songsshan Lake High-tech Industrial Development Zone, Dongguan
Manufacturer:	SINOVOIP CO., LIMITED
Address:	5/F, Comprehensive Building of Zhongxing Industry City, Chuangye Road, Nanshan District, Shenzhen, Guangdong, China
Product:	Banana Pi
Model:	BPI-M2+
Brand Name:	N/A

The submitted products have been tested by us with listed standards and found in compliance with the following European Directives:
The RTTE Directive 1999/5/EC

Applied Standards	Report No.
Article 3.2: Effective Use of The Radio Spectrum EN 300 328 V1.8.1(2012-06)	YRT201605255E-2 YRT201605255E-4
Article 3.1b): Electromagnetic Compatibility EN 301 489-1 V1.9.2: 2011-09 EN 301 489-17 V2.2.1: 2012-09	YRT201605255E-1
Article 3.1a): Health and Safety EN 62479:2010 EN 60950-1:2006+A11:2009+A1:2010+A12:2011+A2:2013	YRT201605255E-3 YRT201605255E-5



Approved by: 

Department Manager
May 26, 2016

SHENZHEN YARUI TESTING CO., LTD.
 Address: No. 620 HuaYuan Commercial Center, No. 347 XiGang Road,XiGang Town, Bao'An District, ShenZhen City
 Tel.: +86-755-27912080 Fax.: +86-755-27916936 Website: www.yaru-lab.com

BPI-M2+ FCC Certification:

CERTIFICAT ♦ CERTIFICADO ♦ YARUITESTING ♦ ZERTIFIKAT ♦ CERTIFICATE

Certificate of Conformity

Certificate No.:	YRT201605257C
Applicant:	GUANGDONG BIPAI KEJI.CPA.,LTD
Address:	7th floor,RongYi Building, Songshan Lake High-tech Industrial Development Zone, Dongguan
Manufacturer:	SINOVOIP CO., LIMITED
Address:	5/F, Comprehensive Building of Zhongxing Industry City, Chuangye Road, Nanshan District, Shenzhen, Guangdong, China
Product:	Banana Pi
Model:	BPI-M2+
Brand Name:	N/A
Report No.:	YRT201605257-1F, YRT201605257-2F

The submitted products have been tested by us with listed standards and found in compliance with the following FCC Rules and Regulations:

The FCC Standard:
FCC CFR 47 PART 15 C(15.247): 2014

The test were performed in normal operation mode. The test results apply only to the particular sample tested and to the specific tests carried out. This certificate applies specifically to the sample investigated in our test reference number only.

The FCC marking as shown below can be affixed on the product after preparation of necessary technical documentation.
Other relevant Directives have to be observed.





Approved by: _____
Department Manager
May 26, 2016

SHENZHEN YARUI TESTING CO., LTD.
Address: No. 620 HuaYuan Commercial Center, No. 347 XiXiang Road, XiXiang Town, Bao'An District, ShenZhen City
Tel.: +86-755-27912080 Fax: +86-755-27916936 Website: www.yarui-lab.com

BPI-M2+ RoHS Certification:

Certificate of Conformity



Certificate No.: YRT201605256C
Applicant: GUANGDONG BIPAI KEJI.CPA.,LTD
Address: 7th floor,RongYi Building, Songshan Lake
 High-tech Industrial Development Zone, Dongguan
Manufacturer: SINOVOIP CO., LIMITED
Address: 5/F, Comprehensive Building of Zhongxing Industry City, Chuangye Road,
 Nanshan District, Shenzhen, Guangdong, China
Product: Banana Pi
Model: BPI-M2+
Brand Name: N/A

The submitted products have been tested by us with listed standards and found in compliance with the following European Directives:

The RoHS Directive 2011/65/EU:

IEC62321-4: 2013;

IEC62321-5: 2013;

IEC62321:2008;

EN 14372:2004;

EPA 3540C:1996

The test were performed in normal operation mode. The test results apply only to the particular sample tested and to the specific tests carried out. This certificate applies specifically to the sample investigated in our test reference number only.

The RoHS marking as shown below can be affixed on the product after preparation of necessary technical documentation.

Other relevant Directives have to be observed.

RoHS

Approved by: _____



Department Manager
May 26, 2016

SHENZHEN YARUI TESTING CO., LTD.

Address: No. 620 HuaYuan Commercial Center, No. 347 XiXiang Road, XiXiang Town, Bao'An District, ShenZhen City

Tel.: +86-755-27912080 Fax.: +86-755-27916936 Website: www.yarui-lab.com

All Banana Pi SBC Comparison

Banana Pi series comparison_20170612

Banana Pi (BPI) Series Comparison

Model	Banana Pi BPI-M1	Banana Pi BPI-M1+	Banana Pi BPI-M2M	Banana Pi BPI-M2+	Banana Pi M2 Berry	Banana Pi BPI-M2 Ultra	Banana Pi BPI-M3	Banana Pi BPI-M64
Photo								
CPU	A20 32 Bit Cortex™-A7 Dual-Core		A83/R16 32 Bit Cortex™-A7 Quad-Core	H3 32 Bit Cortex™-A7 Quad-Core	R40 32 Bit Cortex™-A7 Quad-Core		A83T 32 Bit Cortex™-A7 Octa-Core	A64 64 Bit Cortex A53 Quad Core
GPU	ARM® Mali400MP2		ARM® Mali400MP2	ARM® Mali400MP2	ARM® Mali400MP2		PowerVR SGX544MP2 GPU	ARM® Mali400MP2
SDRAM	1GB DDR3 (shared with GPU)		512MB DDR3	1GB DDR3 (shared with GPU)	1GB DDR3 (shared with GPU)		2GB LPDDR3 (shared with GPU)	2GB DDR3 (shared with GPU)
Storage	SD (Max. 32GB)/MMC card slot SATA 2.0 port via SOC	MicroSD (TF) card / MMC card slot SATA 2.0 port via SOC	MicroSD (TF) card / MMC card slot eMMC 8GB (option)	MicroSD (TF) card / MMC card slot eMMC 8GB	MicroSD (TF) card / MMC card slot SATA 2.0 port via SOC	MicroSD (TF) card / MMC card slot SATA 2.0 port via SOC	MicroSD (TF) card / MMC card slot SATA 2.0 port via USB	MicroSD (TF) card / MMC card slot eMMC 8GB
Network	10/100/1000 Ethernet		N/A	10/100/1000 Ethernet	10/100/1000 Ethernet		10/100/1000 Ethernet	10/100/1000 Ethernet
RF	N/A		802.11b/g/n & BT4.0	802.11b/g/n & BT4.0	802.11b/g/n & BT4.0		802.11b/g/n & BT4.0	802.11b/g/n & BT4.0
Display	HDMI, CVBS, LVDS/RGB		MPI/LVDS	HDMI	HDMI, MIPI		HDMI, MIPI	HDMI, MIPI
Camera	Parallel 8-bit camera interface		Parallel 8-bit camera interface	Parallel 8-bit camera interface	Parallel 8-bit camera interface		Parallel 8-bit camera interface MIPI Camera serial interface(CSI)	Parallel 8-bit camera interface
Video Output	HDMI 1.4@1920*1080P LVDS/Sync RGB/CPU LCD interface up to 1920x1200 Video decoding speed up to 1080p@60fps Video encoding H.264 HP up to 1080p@30fps	Decoding up to 1920x1080@60fps H.264 HP video encoding up to 1920x1080@60fps		Support H.265 decode by 4K@30fps, HDMI 1.4 1080p@60fps Support H.264 video encoding up to 1080p@30fps	HDMI 1.4 1080p@60fps MIPI LCD interface up to 1920x1080 Decoding up to 1920x1080@60fps Video encoding H.264 HP speed up to 1920x1080@30fps		HEVC/H.265 decoder(SW), Main profile, 1080p@30fps H.264 video encoding up to 1080p@60fps, 720p@120fps	Multi-Format FHD video decoding, including Mpeg1/2, Mpeg4, H.263, H.264, etc.H.264 decode up to 1080p@60, H.265 decode up to 4K@30
Audio Output	3.5 mm Jack and HDMI		4ohm/2.5W Speaker (2 Pin Hole)	N/A	3.5 mm Jack and HDMI		3.5 mm Jack and HDMI	3.5 mm Jack and HDMI
Audio In	Microphone		Microphone	HDMI	Microphone		Microphone	Microphone
GPIO	26-PIN: GPIO, UART, I²C bus, SPI bus with two chip selects, CAN bus, PWM, +3.3 V, +5 V, ground	40-PIN: GPIO, UART, I²C bus, I²S bus, SPI bus, +3.3V, +5V, ground	40-PIN: PWM, GPIO, UART, I²C bus, I²S bus, SPI bus, +3.3V, +5V, ground	40-PIN: PWM, GPIO, UART, I²C bus, I²S bus, SPI bus, +3.3V, +5V, ground	40-PIN: PWM, GPIO, UART, I²C bus, I²S bus, SPI bus, +3.3V, +5V, ground.		40-PIN: PWM, GPIO, UART, I²C bus, I²S bus, SPI bus, +3.3V, +5V, ground.	40-PIN: PWM, GPIO, UART, I²C bus, I²S bus, SPI bus, +3.3V, +5V, ground.
Power Source	5 volt via MicroUSB and/or MicroUSB (OTG)		5 volt via DC In and/or MicroUSB (OTG)	5 volt via DC In and/or MicroUSB (OTG)	5 volt via DC In and/or MicroUSB		5 volt via DC In and/or MicroUSB	5 volt via DC In and/or MicroUSB (OTG)
USB 2.0 Ports	2 USB ports, 1 OTG microUSB port		1 USB 2.0 ports, 1 OTG microUSB port	2 USB ports, 1 OTG microUSB port	4 USB ports, 1 OTG microUSB port		2 USB ports, 1 OTG microUSB port	2 USB ports, 1 OTG microUSB port
Buttons	Reset button, Power button, Uboot button		Reset button, Power button, Uboot button	Reset button, Power button, Uboot button	Reset button, Power button, Uboot button		Reset button, Power button, Uboot button	Reset button, Power button, Uboot button
LED	Power LED (red), RJ45 LED (blue), user define LED (green)		User define LED (red/power, blue, green)	Power LED (red, Can be defined by user)	User define LED (red/power, blue, green)		User define LED (red/power, blue, green)	User define LED (red/power, blue, green)
Remote	IR receiver		N/A	IR receiver	IR receiver		IR receiver	IR receiver
Board Size	92 mm × 60mm		51 mm × 51mm	65 × 65mm	85mm × 55mm		92 mm × 60mm	92 mm × 60mm
Box Size				20 mm × 80mm × 105mm				
Weight	60g			48g			60g	
OS				Android and Linux etc. OS				Android 5.1 & Linux OS





Banana Pi series comparison_20170612 excel file download:

<https://drive.google.com/file/d/0B4PAo2nW2KfnUIVfQ2NQRTF2b2M/view?usp=sharing>

Banana Pi series comparison_20170612 pdf file download:

<https://drive.google.com/file/d/0B4PAo2nW2KfnaG8zdXBhUTuUYXc/view?usp=sharing>

Banana Pi (BPI) Series Comparison

Model	Banana Pi BPI-M1	Banana Pi BPI-M1+	Banana Pi BPI-M2+	Banana Pi BPI-M2	Banana Pi BPI-M3
Photo					
CPU	A20 Cortex™-A7 Dual-Core		H3 Cortex™-A7 Quad-Core	A31S Cortex™-A7 Quad-Core	A83T Cortex™-A7 Octa-Core
GPU	ARM® Mali400MP2 Complies with OpenGL ES 2.0/1.1			PowerVR SGX544MP2 GPU Support OpenGL ES 2.0, OpenVG 1.1, and DX 9.3 standards	
SDRAM	1GB DDR3 (shared with GPU)			2GB LPDDR3 (shared with GPU)	
Storage	SD (Max. 32GB)/MMC card slot, SATA 2.0 port	MicroSD (TF) card SATA 2.0 port	MicroSD (TF) card, eMMC 8GB	MicroSD (TF) card / MMC card slot	MicroSD (TF) card, eMMC 8GB SATA 2.0 port (via USB to SATA)
Network	10/100/1000 Ethernet		10/100/1000 Ethernet	10/100/1000 Ethernet	
RF	N/A		802.11b/g/n	802.11b/g/n	802.11b/g/n & BT4.0
Display	HDMI, CVBS, LVDS/RGB		HDMI	HDMI, LVDS/RGB	HDMI, MIPI Display Serial Interface (DSI)
Camera	Parallel 8-bit camera interface		Parallel 8-bit camera interface	Parallel 8-bit camera interface	Parallel 8-bit camera interface MIPI Camera serial interface(CSI)
Video Outputs	HDMI 1.4 transmitter with HDCP LVDS/Sync RGB/CPU LCD interface up to 1920x1200 Video decoding speed up to 1080p@60fps Video encoding H.264 HP up to 1080p@30fps		Support H.265 decode by 4K@30fps, HDMI 1.4 1080p@60fps Support H.264 video encoding up to 1080p@30fps	HDMI 1.4 1080p@60fps LVDS/RGB/CPU LCD interface 1280x800 Decoding up to 1920x1080@60fps Video encoding H.264 HP: speed up 1920x1080@30fps	Support 4-lane MIPI DSI up to 1920x1200@60Hz HDMI 1.4 output with HDCP 1.2 Support LVDS up to 1366x768@60Hz HEVC/H.265 decoder(SW), Main profile, 1080p@30fps H.264 video encoding up to 1080p@60fps, 720p@120fps
Audio Output	3.5 mm Jack and HDMI		HDMI	3.5 mm Jack and HDMI	
GPIO	26-PIN: GPIO, UART, I²C bus, SPI bus with two chip selects, CAN bus, PWM, +3.3 V, +5 V, ground	40-PIN: GPIO, UART, I²C bus, I²S bus, SPI bus with two chip selects, CAN bus, PWM, +3.3 V, +5 V, ground	40-PIN: PWM, GPIO, UART, I²C bus, I²S bus, SPI bus, +3.3V, +5V, ground.		
Power Source	5 volt via MicroUSB and/or MicroUSB (OTG)		5 volt via DC In and/or MicroUSB (OTG)		
USB 2.0 Ports	2 USB ports, 1 OTG microUSB port		4 USB 2.0 ports, 1 OTG microUSB port		2 USB 2.0 ports, 1 OTG microUSB port
Buttons	Reset button, Power button, Uboot button		Power button, Uboot button		Reset button, Power button, Uboot button
LED	Power LED (red), RJ45 LED (blue), user define LED (green)		Power LED (red, Can be defined by user)	User define LED (red/power, blue, green)	
Remote	IR receiver		IR receiver		
Board Size	92 mm × 60mm		65 × 65mm	92 mm × 60mm	
Box Size			20 mm × 80mm × 105mm		
Weight	60g		48g	60g	
OS			Android 4.4 and Linux etc. OS	Android 5.1 & Linux OS	

All banana pi product

- **banana pi BPI-M1 allwinner A20 dual core single board computer**
gitbook online datasheet:<https://bananapi.gitbooks.io/bpi-m1/content/en/>
- **banana pi BPI-M1+(BPI-M1+ plus) allwinner A20 dual core single board computer**
gitbook online datasheet:<https://bananapi.gitbooks.io/bpi-m1-bpi-m1-plus-/content/en/>
- **banana pi BPI-M2+ (BPI-M2 Plus,BPI-M2+ edu) allwinner H3/H2+/H5 quad cord single board computer**
gitbook online datasheet:<https://bananapi.gitbooks.io/bpi-m2-/content/en/>
- **banana pi BPI-M2 Ultra allwinner R40/V40 quad core single board computer**
gitbook online datasheet:<https://bananapi.gitbooks.io/bpi-m2-ultra/content/>
- **banana pi BPI-M2 Berry allwinner R40/V40 quad core single board computer**
gitbook online datasheet:<https://bananapi.gitbooks.io/bpi-m2-ultra/content/>
- **banana pi BPI-M2 Magic allwinner R16/A33 quad core single board computer**
gitbook online datasheet: <https://bananapi.gitbooks.io/banana-pi-bpi-m2-magic-iot-development-board/content/>
- **Banana pi BPI-M3 allwinner A83T (R58 H8) octa-core single board computer**
gitbook online datasheet:<https://bananapi.gitbooks.io/bpi-m3/content/en/>
- **banana pi BPI-M64 allwinner A64/R18 64 bit single board computer**
gitbook online datasheet:<https://bananapi.gitbooks.io/bpi-m64/content/en/>
- **banana pi BPI-R1 allwinner A20 dual core smart router board**
gitbook online datasheet:<https://bananapi.gitbooks.io/bpi-r1/content/en/>
- **banana pi BPI-R2 MTK 7623N smart router board**
gitbook online datasheet:<https://bananapi.gitbooks.io/banana-pi-bpi-r2-open-source-smart-router/content/>
- **banana pi BPI-D1 open source IP camera board**
gitbook online datasheet:<https://bananapi.gitbooks.io/bpi-d1/content/en/>
- **banana pi BPI-G1 open source IoT development board**
gitbook online datasheet:<https://bananapi.gitbooks.io/bpi-g1/content/en/>
- **banana pi BPI Accessories**
gitbook online datasheet:<https://bananapi.gitbooks.io/bpi-accessories/content/en/>
- **BPI Open debugger burn development tool board**
gitbook online datasheet:<https://bananapi.gitbooks.io/bpi-open-debugger-burn-board/content/en/>

Stop production

- **banana pi BPI-M2 allwinner A31s quad core single board computer**
- gitbook online datasheet:datasheet: <https://bananapi.gitbooks.io/bpi-m2/content/en/>

BPI 4.0 customized Server

Having been doing R&D in embeded systems for more than 12 years. Our experienced teams are able to help you to carry out your dream. Whether you want to customize banana pi or want to design a computer from scratch, we got you covered. Also, our modern ISO factory spans over 10,000 square meters can help you mass manufacture products to hit the market

Our factory:Sinovoip In order to meet the companys development needs, and further production capacity and product quality. Sources Communication shareholders decided to invest in new plant to build their own, the new factory site is located in manholes and covers an area of more than 10000 square meters,equipped with full range of production equipment and high quality technical management personnel . We have complete SMT production lines, plug-ins production line, assembly line, production line testing.

- your Idea, we will help you optimize and design.
- your Design, we will help you bring it to live.
- your Product, we will help you mass produce it.

Customize Pi

If you want to tailor your Banana pi to your specific use or to minimize the cost for mass production purpose, you are coming the right place. We provide the customization service of banana pi such as remove/add headers or connectors,change component layout,add/remove components,change interfaces etc.

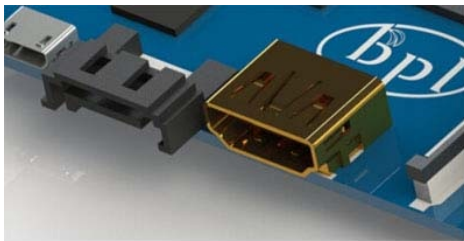

add/remove headers or connectors



add peripheral converter



Start from scratch (ODM)

An idea flashes through your mind in your dreams or a solution bearing in your mind for a long time, which you think would turn out to be great gadget to hit the market, but you are worrying about how to start and realize it without R&D and manufacturing, now that's no longer a trouble to you. Taking advantage of our expertise,we provide full ODM service for you. We let you have your sample products from scratch within 45 days. Don't wait,come to realize your dreams.

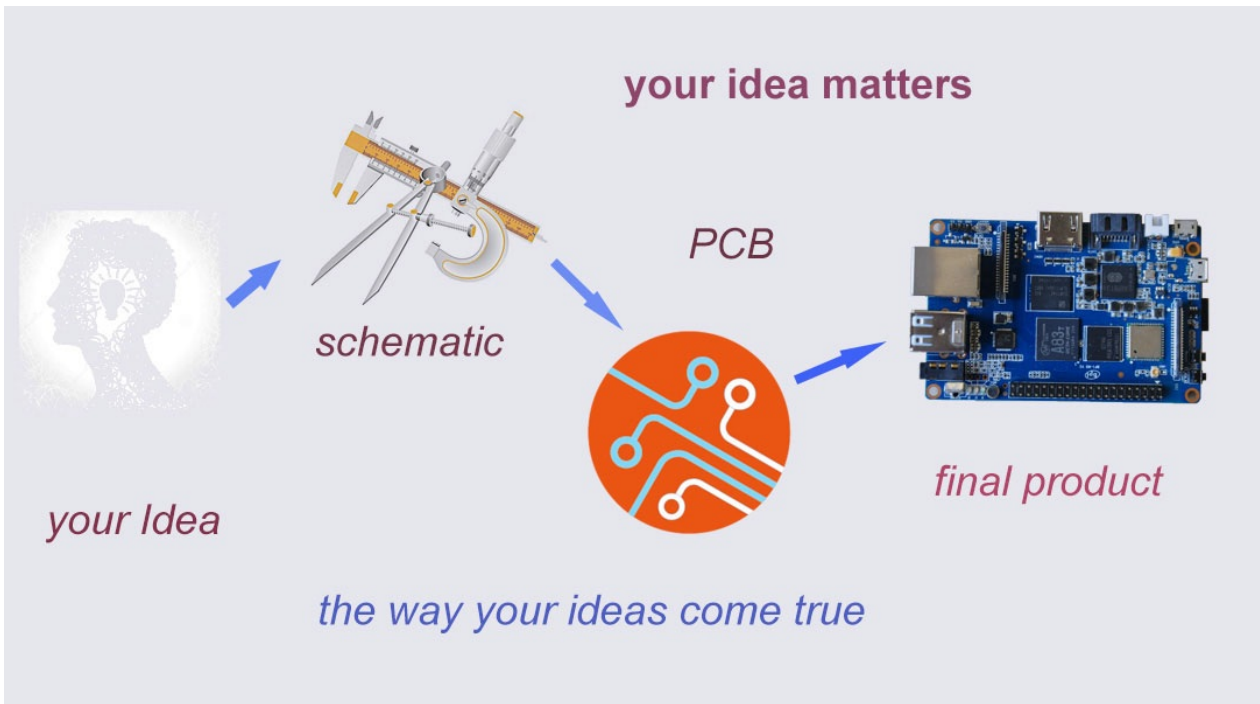

Have a prototype (OEM)

You are an expert, you designed a wonderful device that most people would want to have it, you knew it quite well that your success is just around the corner. The only last step is to produce it, but without manufacturing capability..., no problem, let us carry you through. Our 13 years of SCM experience and mass manufacturing facilities enable you free from quality issue, delivery...

ISO9000 **ISO14000**

13 years of SCM experience

The central graphic consists of a red-outlined floor plan of a factory or manufacturing facility. Surrounding this central element are several icons: a circular connector, a camera, a PCB, a microchip, and a photograph of a factory interior with machinery.