

Single, Digitally Controlled (XDCP™) Potentiometer

FEATURES

- 256 Resistor Taps
- SPI Serial Interface for Write, Read, and Transfer Operations of Potentiometer
- Wiper Resistance, 100Ω typical @ V_{CC} = 5V
- 16 Nonvolatile Data Registers
- Nonvolatile Storage of Multiple Wiper Positions
- Power-on Recall; Loads Saved Wiper Position on Power-up
- Standby Current < 3μA Max
- V_{CC} = 2.7V to 5.5V Operation
- 50kΩ, 100kΩ Versions of End-to-End Resistance
- 100-yr Data Retention
- Endurance: 100,000 Data Changes per Bit per Register
- 14-Lead TSSOP
- Low-power CMOS
- Pb-free Plus Anneal Available (RoHS Compliant)

DESCRIPTION

The X9271 integrates a single, digitally controlled potentiometer (XDCP™) on a monolithic CMOS integrated circuit.

The digitally controlled potentiometer is implemented by using 255 resistive elements in a series array. Between each element are tap points connected to the wiper terminal through switches. The position of the wiper on the array is controlled by the user through the SPI bus interface. The potentiometer has associated with it a volatile Wiper Counter Register (WCR) and four nonvolatile data registers that can be directly written to and read by the user. The contents of the WCR control the position of the wiper on the resistor array through the switches. Power-up recalls the contents of the default data register (DR0) to the WCR.

The XDCP can be used as a three-terminal potentiometer or as a two-terminal variable resistor in a wide variety of applications, including control, parameter adjustments, and signal processing.

FUNCTIONAL DIAGRAM

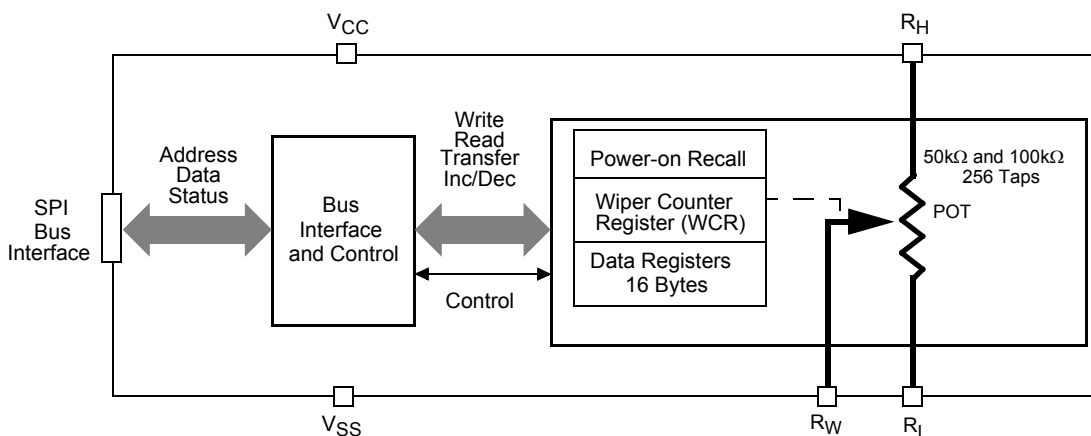

Ordering Information

PART NUMBER (Notes 1, 3)	PART MARKING	V _{CC} LIMITS (V)	POTENTIOMETER ORGANIZATION (k Ω)	TEMP. RANGE (°C)	PACKAGE	PKG. DWG. #
X9271UV14IZ (Note 2)	X9271 UVZI	5 \pm 10%	50	-40 to +85	14 Ld TSSOP (4.4mm) (Pb-free)	M14.173
X9271UV14Z (Note 2)	X9271 UVZ	5 \pm 10%	50	0 to +70	14 Ld TSSOP (4.4mm) (Pb-free)	M14.173
X9271TV14 (Note 4)	X9271 TV	5 \pm 10%	100	0 to +70	14 Ld TSSOP (4.4mm)	M14.173
X9271TV14I-2.7T1 (Note 4)	X9271 TVG	2.7 to 5.5	100	-40 to +85	14 Ld TSSOP (4.4mm)	M14.173
X9271TV14IZ (Note 2)	X9271 TVZI	5 \pm 10%	100	-40 to +85	14 Ld TSSOP (4.4mm) (Pb-free)	M14.173
X9271TV14Z (Note 2)	X9271 TVZ	5 \pm 10%	100	0 to +70	14 Ld TSSOP (4.4mm) (Pb-free)	M14.173
X9271UV14I-2.7 (Note 4)	X9271 UVG	2.7 to 5.5	50	-40 to +85	14 Ld TSSOP (4.4mm)	M14.173
X9271UV14IZ-2.7 (Note 2)	X9271 UVZG	2.7 to 5.5	50	-40 to +85	14 Ld TSSOP (4.4mm) (Pb-free)	M14.173
X9271UV14Z-2.7 (Note 2)	X9271 UVZF	2.7 to 5.5	50	0 to +70	14 Ld TSSOP (4.4mm) (Pb-free)	M14.173
X9271TV14IZ-2.7 (Note 2)	X9271 TVZG	2.7 to 5.5	50	-40 to +85	14 Ld TSSOP (4.4mm) (Pb-free)	M14.173
X9271TV14Z-2.7 (Note 2)	X9271 TVZF	2.7 to 5.5	100	0 to +70	14 Ld TSSOP (4.4mm) (Pb-free)	M14.173

NOTES:

1. Add "-T*" suffix for tape and reel. Please refer to [TB347](#) for details on reel specifications.
2. These Intersil Pb-free plastic packaged products employ special Pb-free material sets, molding compounds/die attach materials, and 100% matte tin plate plus anneal (e3 termination finish, which is RoHS compliant and compatible with both SnPb and Pb-free soldering operations). Intersil Pb-free products are MSL classified at Pb-free peak reflow temperatures that meet or exceed the Pb-free requirements of IPC/JEDEC J STD-020.
3. For Moisture Sensitivity Level (MSL), please see device information page for [X9271](#). For more information on MSL please see Tech Brief [TB363](#).
4. Not recommended for new designs.

DETAILED FUNCTIONAL DIAGRAM

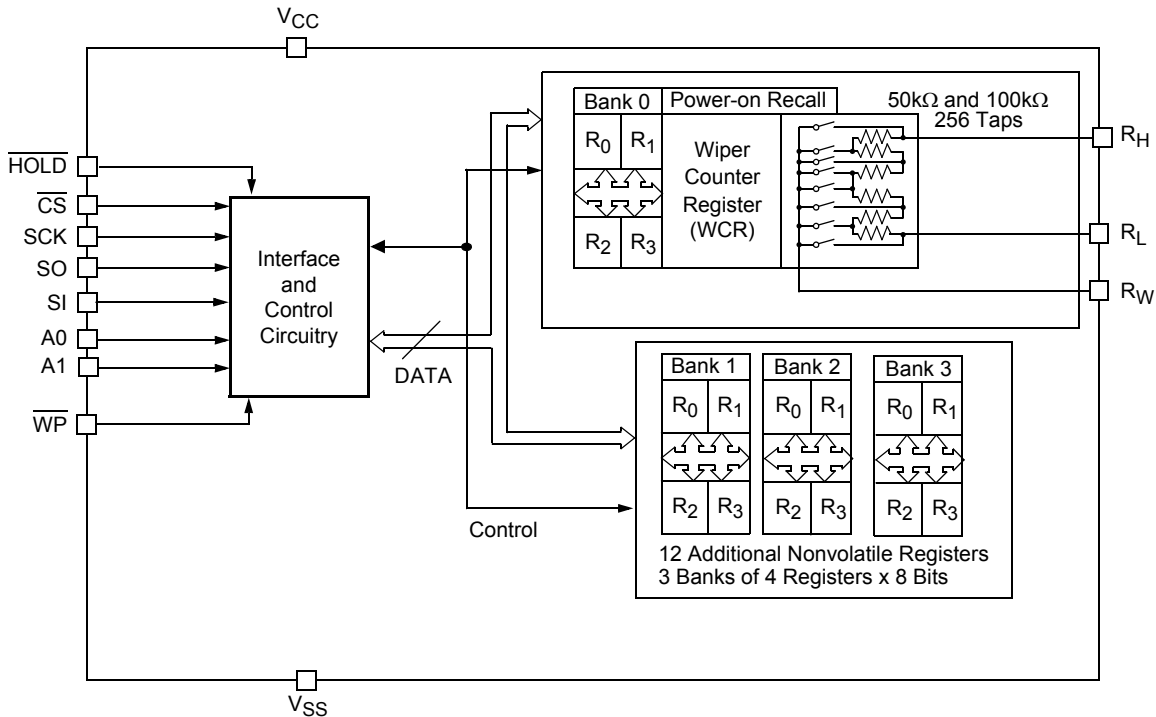

CIRCUIT-LEVEL APPLICATIONS

- Vary the gain of a voltage amplifier.
- Provide programmable DC reference voltages for comparators and detectors.
- Control the volume in audio circuits.
- Trim out the offset voltage error in a voltage amplifier circuit.
- Set the output voltage of a voltage regulator.
- Trim the resistance in Wheatstone bridge circuits.
- Control the gain, characteristic frequency, and Q-factor in filter circuits.
- Set the scale factor and zero point in sensor signal conditioning circuits.
- Vary the frequency and duty cycle of timer ICs.
- Vary the DC biasing of a pin diode attenuator in RF circuits.
- Provide a control variable (I, V, or R) in feedback circuits.

SYSTEM-LEVEL APPLICATIONS

- Adjust the contrast in LCD displays.
- Control the power level of LED transmitters in communication systems.
- Set and regulate the DC biasing point in an RF power amplifier in wireless systems.
- Control the gain in audio and home entertainment systems.
- Provide the variable DC bias for tuners in RF wireless systems.
- Set the operating points in temperature control systems.
- Control the operating point for sensors in industrial systems.
- Trim offset and gain errors in artificial intelligence systems.

PIN CONFIGURATION

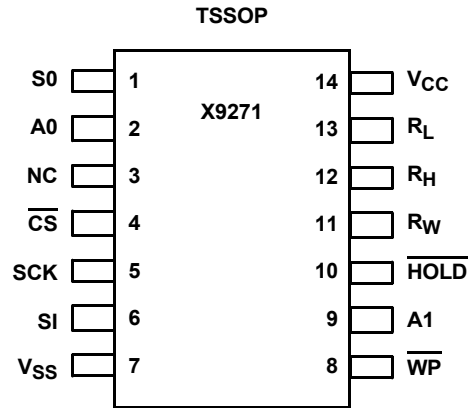

PIN ASSIGNMENTS

TSSOP	Symbol	Function
1	SO	Serial Data Output
2	A0	Device Address
3	NC	No Connect
4	$\overline{\text{CS}}$	Chip Select
5	SCK	Serial Clock
6	SI	Serial Data Input
7	V _{SS}	System Ground
8	$\overline{\text{WP}}$	Hardware Write Protect
9	A1	Device Address
10	$\overline{\text{HOLD}}$	Device Select. Pause the serial bus.
11	R _W	Wiper Terminal of Potentiometer
12	R _H	High Terminal of Potentiometer
13	R _L	Low Terminal of Potentiometer
14	V _{CC}	System Supply Voltage

PIN DESCRIPTIONS

Bus Interface Pins

SERIAL OUTPUT (SO)

The Serial Output (SO) is the serial data output pin. During a read cycle, data is shifted out on this pin. Data is clocked out by the falling edge of the serial clock.

SERIAL INPUT (SI)

The Serial Input (SI) is the serial data input pin. All operational codes, byte addresses, and data to be written to the potentiometers and potentiometer registers are input on this pin. Data is latched by the rising edge of the serial clock.

SERIAL CLOCK (SCK)

The Serial Clock (SCK) input is used to clock data into and out of the X9271.

HOLD ($\overline{\text{HOLD}}$)

$\overline{\text{HOLD}}$ is used in conjunction with the $\overline{\text{CS}}$ pin to select the device. Once the part is selected and a serial sequence is under way, $\overline{\text{HOLD}}$ may be used to pause the serial communication with the controller without resetting the serial sequence. To pause, $\overline{\text{HOLD}}$ must be brought LOW while SCK is LOW. To resume communication, $\overline{\text{HOLD}}$ is brought HIGH, again while SCK is LOW. If the pause feature is not used, $\overline{\text{HOLD}}$ should be held HIGH at all times. CMOS level input.

DEVICE ADDRESS (A1 - A0)

The Device Address (A1 - A0) inputs are used to set the 8-bit slave address. A match in the slave address serial data stream must be made with the address input in order to initiate communication with the X9271.

CHIP SELECT ($\overline{\text{CS}}$)

When Chip Select ($\overline{\text{CS}}$) is HIGH, the X9271 is deselected, the SO pin is at high impedance, and (unless an internal write cycle is under way) the device is in standby state. $\overline{\text{CS}}$ LOW enables the X9271, placing it in the active power mode. It should be noted that after a power-up, a HIGH to LOW transition on $\overline{\text{CS}}$ is required prior to the start of any operation.

Potentiometer Pins

R_H , R_L

The R_H and R_L pins are equivalent to the terminal connections on a mechanical potentiometer.

R_W

The wiper pin (R_W) is equivalent to the wiper terminal of a mechanical potentiometer.

Supply Pins

SYSTEM SUPPLY VOLTAGE (V_{CC}) AND SUPPLY GROUND (V_{SS})

The System Supply Voltage (V_{CC}) pin is the system supply voltage. The Supply Ground (V_{SS}) pin is the system ground.

Other Pins

HARDWARE WRITE PROTECT INPUT ($\overline{\text{WP}}$)

The Hardware Write Protect Input ($\overline{\text{WP}}$) pin, when LOW, prevents nonvolatile writes to the data registers.

NO CONNECT

No Connect pins should be left floating. These pins are used for Intersil manufacturing and testing purposes.

PRINCIPLES OF OPERATION

Device Description

SERIAL INTERFACE

The X9271 supports the SPI interface hardware conventions. The device is accessed via the SI input with data clocked in on the rising SCK. CS must be LOW and the HOLD and WP pins must be HIGH during the entire operation.

The SO and SI pins can be connected together, since they have three state outputs. This can help to reduce system pin count.

ARRAY DESCRIPTION

The X9271 is composed of a resistor array (Figure 1). The array contains the equivalent of 255 discrete resistive segments that are connected in series. The

physical ends of each array are equivalent to the fixed terminals of a mechanical potentiometer (R_H and R_L inputs).

At both ends of each array and between each resistor segment is a CMOS switch connected to the wiper (R_W) output. Within each individual array, only one switch may be turned on at a time.

These switches are controlled by a Wiper Counter Register (WCR). The eight bits of the WCR ($WCR[7:0]$) are decoded to select, and enable, one of 256 switches (Table 1).

POWER-UP AND POWER-DOWN RECOMMENDATIONS

There are no restrictions on the power-up or power-down conditions of V_{CC} and the voltages applied to the potentiometer pins, provided that V_{CC} is always more positive than or equal to V_H , V_L , and V_W ; i.e., $V_{CC} \geq V_H, V_L, V_W$. The V_{CC} ramp rate specification is always in effect.

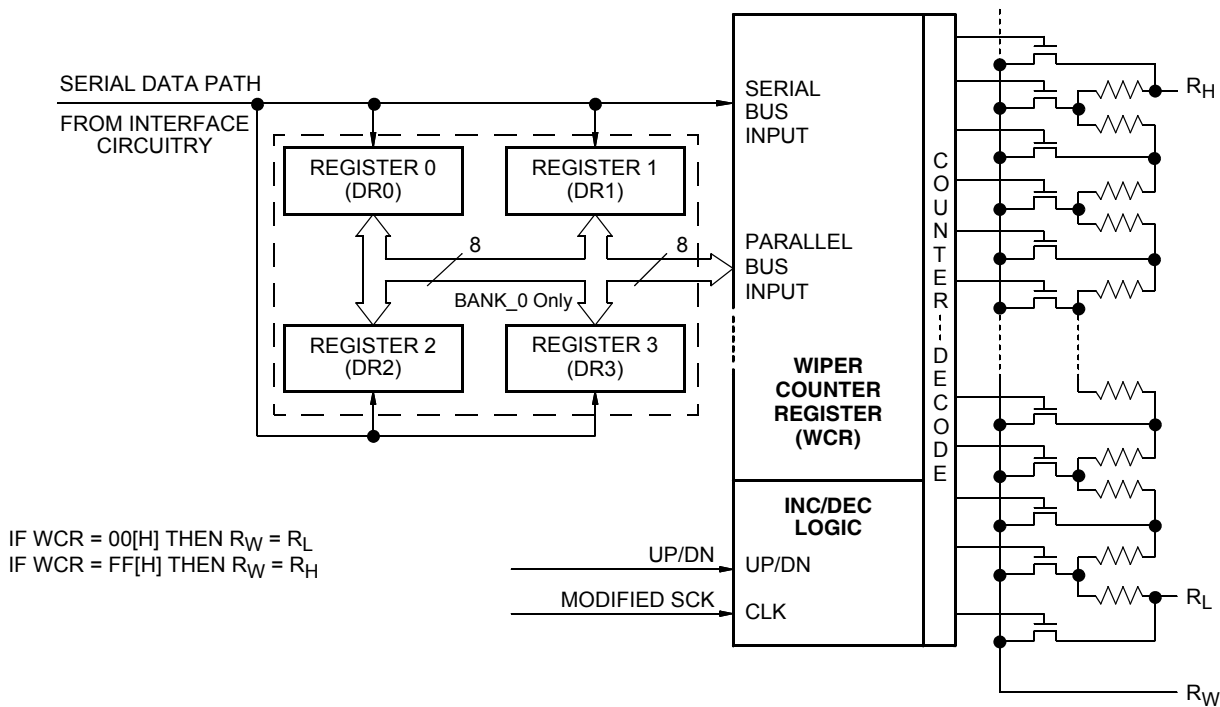

FIGURE 1. DETAILED POTENTIOMETER BLOCK DIAGRAM

DEVICE DESCRIPTION

Wiper Counter Register (WCR)

The X9271 contains a Wiper Counter Register (WCR) for the DCP potentiometer. The WCR can be envisioned as an 8-bit parallel and serial load counter, with its outputs decoded to select one of 256 switches along its resistor array (Table 1). The contents of the WCR can be altered in four ways:

1. It can be written directly by the host via the Write Wiper Counter Register instruction (serial load).
2. It can be written indirectly by transferring the contents of one of four associated data registers via the XFR Data Register instruction (parallel load).
3. It can be modified one step at a time by the Increment/Decrement instruction.
4. It is loaded with the contents of its Data Register zero (DR0) upon power-up.

The WCR is a volatile register; that is, its contents are lost when the X9271 is powered down. Although the register is automatically loaded with the value in DR0 upon power-up, this may be different from the value present at power-down. Power-up guidelines are recommended to ensure proper loading of the R0 value into the WCR. The DR0 value of Bank 0 is the default value.

Data Registers (DR3–DR0)

The potentiometer has four 8-bit nonvolatile Data Registers. These can be read or written directly by the host (Table 2). Data can also be transferred between any of the four Data Registers and the associated WCR. All operations changing data in one of the Data Registers are nonvolatile operations and take a maximum of 10ms.

If the application does not require storage of multiple settings for the potentiometer, the Data Registers can be used as regular memory locations for system parameters or user preference data.

Bits [7:0] are used to store one of the 256 wiper positions or data (0 ~255).

Status Register (SR)

The 1-bit Status Register is used to store the system status (Table 3).

WIP: Write In Progress status bit; read only.

- WIP = 1 indicates that a high-voltage write cycle is in progress.
- WIP = 0 indicates that no high-voltage write cycle is in progress

TABLE 1. WIPER COUNTER REGISTER, WCR (8-bit), WCR[7:0]: Used to store current wiper position (Volatile, V)

WCR7	WCR6	WCR5	WCR4	WCR3	WCR2	WCR1	WCR0
V	V	V	V	V	V	V	V
(MSB)							(LSB)

TABLE 2. DATA REGISTER, DR (8-BIT), DR[7:0]: Used to store wiper positions or data (Nonvolatile, NV)

BIT 7	BIT 6	BIT 5	BIT 4	BIT 3	BIT 2	BIT 1	BIT 0
NV	NV	NV	NV	NV	NV	NV	NV
MSB							LSB

TABLE 3. STATUS REGISTER, SR (WIP is 1-bit)

WIP
(LSB)

DEVICE DESCRIPTION

Instructions

IDENTIFICATION BYTE (ID AND A)

The first byte sent to the X9271 from the host, following a CS going HIGH to LOW, is called the Identification byte. The most significant four bits of the slave address are a device type identifier. The ID[3:0] bit is the device ID for the X9271; this is fixed as 0101[B] (Table 4).

The A1 - A0 bits in the ID byte are the internal slave address. The physical device address is defined by the state of the A1 - A0 input pins. The slave address is externally specified by the user. The X9271 compares the serial data stream with the address input state; a successful compare of both address bits is required for the X9271 to successfully continue the command sequence. Only the device for which slave address matches the incoming device address sent by the master executes the instruction. The A1 - A0 inputs can be actively driven by CMOS input signals or tied to V_{CC} or V_{SS}.

INSTRUCTION BYTE (I[3:0])

The next byte sent to the X9271 contains the instruction and register pointer information. The three most significant bits are used to provide the instruction operation code (I[3:0]). The RB and RA bits point to one of the four Data Registers. P0 is the POT selection; since the X9271 is single POT, P0 = 0. The format is shown in Table 7.

REGISTER BANK SELECTION (R1, R0, P1, P0)

There are 16 registers organized into four banks. Bank 0 is the default bank of registers. Only Bank 0 registers can be used for the data register to Wiper Counter Register operations.

Banks 1, 2, and 3 are additional banks of registers (12 total) that can be used for SPI write and read operations. The data registers in Banks 1, 2, and 3 cannot be used for direct read/write operations to the Wiper Counter Register (Tables 5 and 6).

TABLE 4. IDENTIFICATION BYTE FORMAT

DEVICE TYPE IDENTIFIER				SET TO 0 FOR PROPER OPERATION		INTERNAL SLAVE ADDRESS	
ID3	ID2	ID1	ID0	0	0	A1	A0
0	1	0	1				
(MSB)							(LSB)

TABLE 5. REGISTER SELECTION (DR0 TO DR3) TABLE

RB	RA	REGISTER SELECTION	OPERATIONS
0	0	0	Data Register Read and Write; Wiper Counter Register Operations
0	1	1	Data Register Read and Write; Wiper Counter Register Operations
1	0	2	Data Register Read and Write; Wiper Counter Register Operations
1	1	3	Data Register Read and Write; Wiper Counter Register Operations

TABLE 6. REGISTER BANK SELECTION (BANK 0 TO BANK 3)

P1	P0	BANK SELECTION	OPERATIONS
0	0	0	Data Register Read and Write; Wiper Counter Register Operations
0	1	1	Data Register Read and Write Only
1	0	2	Data Register Read and Write Only
1	1	3	Data Register Read and Write Only

TABLE 7. INSTRUCTION BYTE FORMAT

INSTRUCTION OPCODE				REGISTER SELECTION		REGISTER BANK SELECTION FOR SPI REGISTER WRITE AND READ OPERATIONS		
						P1	POTENTIOMETER SELECTION (WCR SELECTION) (Note 5)	
I3	I2	I1	P0	RB	RA		P1	P0
(MSB)								(LSB)

NOTE:

- 5. Set to P0 = 0 for potentiometer operations.

DEVICE DESCRIPTION

Instructions

Five of the eight instructions are three bytes in length. These instructions are:

- **Read Wiper Counter Register:** Read the current wiper position of the potentiometer.
- **Write Wiper Counter Register:** Change current wiper position of the potentiometer.
- **Read Data Register:** Read the contents of the selected Data Register.
- **Write Data Register:** Write a new value to the selected Data Register.
- **Read Status:** This command returns the contents of the WIP bit, which indicates if the internal write cycle is in progress.

See Table 8 for details of the instruction set.

The basic sequence of the 3-byte instruction is shown in Figure 2. These 3-byte instructions exchange data between the WCR and one of the Data Registers. A transfer from a Data Register to a WCR is essentially a write to a static RAM, with the static RAM controlling the wiper position. The response of the wiper to this action is delayed by t_{WRL} . A transfer from the WCR (current wiper position) to a Data Register is a write to nonvolatile memory and takes a minimum of t_{WR} to complete. The transfer can occur between one of the four potentiometers and one of its associated registers, or it may occur globally, where the transfer occurs between all potentiometers and one associated register. The Read Status Register instruction is the only unique format (Figure 3).

Two instructions require a 2-byte sequence to complete (Figure 4). These instructions transfer data between the host and the X9271; either between the host and one of the data registers, or directly between the host and the Wiper Counter Register. These instructions are:

- **XFR Data Register to Wiper Counter Register:** Transfers the contents of one specified Data Register to the associated Wiper Counter Register.
- **XFR Wiper Counter Register to Data Register:** Transfers the contents of the specified Wiper Counter Register to the associated Data Register.

The final command is Increment/Decrement (Figures 5 and 6). It is different from the other commands, because its length is indeterminate. Once the command is issued, the master can clock the selected wiper up and/or down in one resistor segment step, thereby providing a fine-tuning capability to the host. For each SCK clock pulse (t_{HIGH}) while SI is HIGH, the selected wiper moves one resistor segment towards the R_H terminal. Similarly, for each SCK clock pulse while SI is LOW, the selected wiper moves one resistor segment towards the R_L terminal.

Write-in-Process (WIP) Bit

The contents of the Data Registers are saved to nonvolatile memory when the \overline{CS} pin goes from LOW to HIGH after a complete write sequence is received by the device. The progress of this internal write operation can be monitored by the Write-in-Process bit (WIP). The WIP bit is read with a Read Status command.

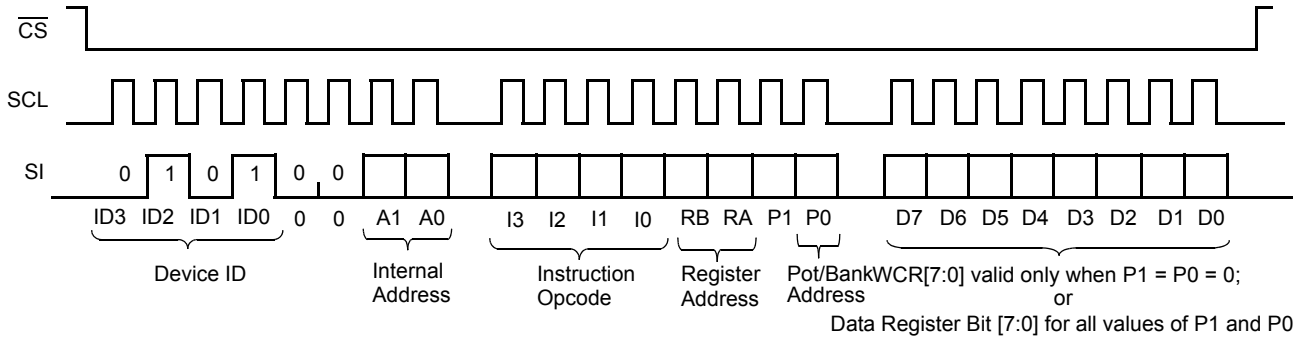

FIGURE 2. THREE-BYTE INSTRUCTION SEQUENCE (WRITE)

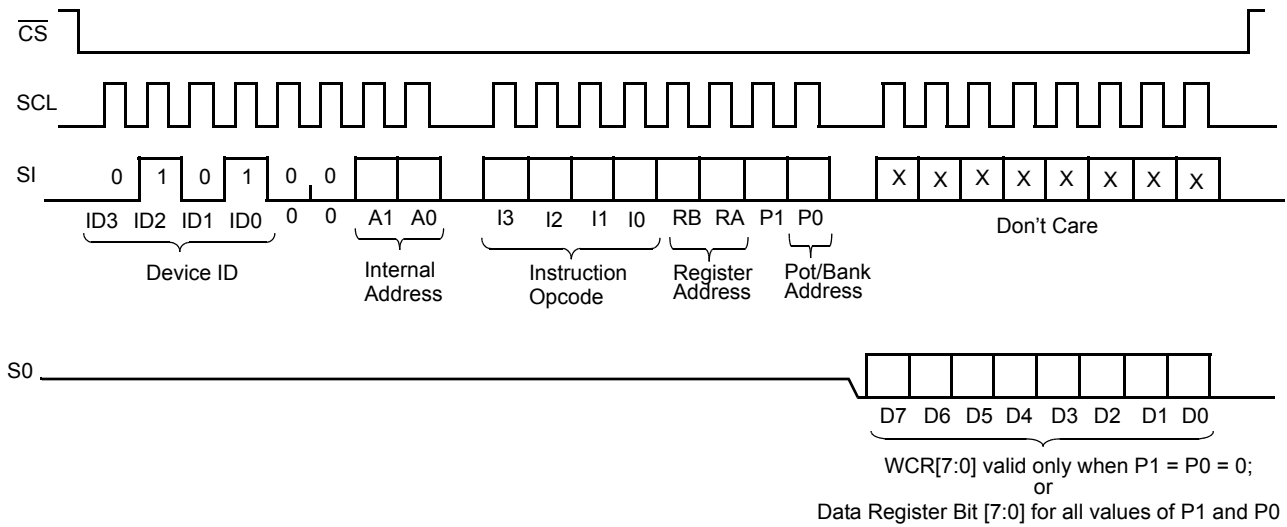
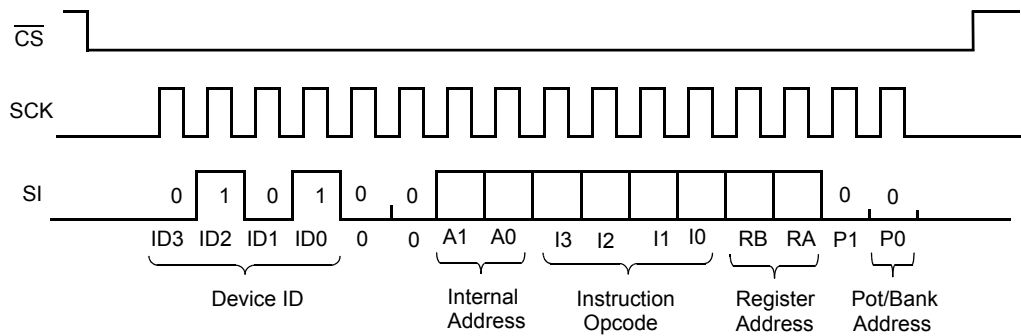

FIGURE 3. THREE-BYTE INSTRUCTION SEQUENCE (READ)



These commands only valid when P1 = P0 = 0

FIGURE 4. TWO-BYTE INSTRUCTION SEQUENCE

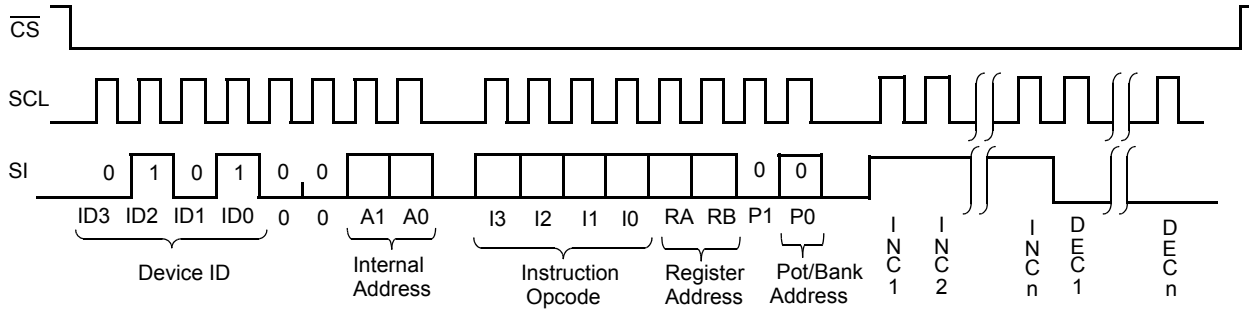

FIGURE 5. INCREMENT/DECREMENT INSTRUCTION SEQUENCE

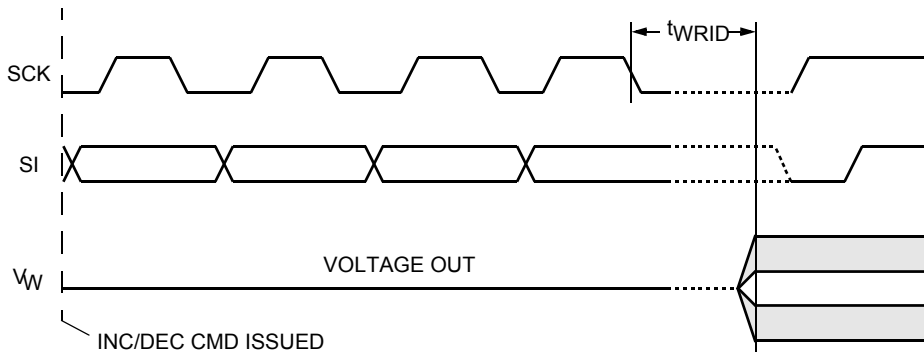

FIGURE 6. INCREMENT/DECREMENT TIMING LIMITS

TABLE 8. INSTRUCTION SET

INSTRUCTION	INSTRUCTION SET (1/0 = DATA IS ONE OR ZERO)								OPERATION
	I3	I2	I1	I0	RB	RA	P ₁	P ₀	
Read Wiper Counter Register	1	0	0	1	0	0	0	1/0	Read contents of Wiper Counter Register.
Write Wiper Counter Register	1	0	1	0	0	0	0	1/0	Write new value to Wiper Counter Register.
Read Data Register	1	0	1	1	1/0	1/0	1/0	1/0	Read contents of Data Register pointed to by P ₁ - P ₀ and RB - RA.
Write Data Register	1	1	0	0	1/0	1/0	1/0	1/0	Write new value to Data Register pointed to by P ₁ - P ₀ and RB - RA.
XFR Data Register to Wiper Counter Register	1	1	0	1	1/0	1/0	0	0	Transfer contents of Data Register pointed to by RB - RA (Bank 0 only) to Wiper Counter Register.
XFR Wiper Counter Register to Data Register	1	1	1	0	1/0	1/0	0	0	Transfer contents of Wiper Counter Register to Register pointed to by RB-RA (Bank 0 only).
Increment/Decrement Wiper Counter Register	0	0	1	0	0	0	0	0	Enable increment/decrement of the Wiper Counter Register.
Read Status (WIP Bit)	0	1	0	1	0	0	0	1	Read status of internal write cycle by checking WIP bit.

INSTRUCTION FORMAT

Read Wiper Counter Register (WCR)

$\overline{\text{CS}}$ Falling Edge	Device Type Identifier				Device Addresses				Instruction Opcode				DR/Bank Addresses				Wiper Position (Sent by X9271 on SO)								$\overline{\text{CS}}$ Rising Edge
	0	1	0	1	0	0	A1	A0	1	0	0	1	0	0	0	0	W7	W6	W5	W4	W3	W2	W1	W0	
	0	1	0	1	0	0	A1	A0	1	0	0	1	0	0	0	0	W7	W6	W5	W4	W3	W2	W1	W0	

Write Wiper Counter Register (WCR)

$\overline{\text{CS}}$ Falling Edge	Device Type Identifier				Device Addresses				Instruction Opcode				DR/Bank Addresses				Data Byte (Sent by Host on SI)								$\overline{\text{CS}}$ Rising Edge
	0	1	0	1	0	0	A1	A0	1	0	1	0	0	0	0	0	W7	W6	W5	W4	W3	W2	W1	W0	
	0	1	0	1	0	0	A1	A0	1	0	1	0	0	0	0	0	W7	W6	W5	W4	W3	W2	W1	W0	

Read Data Register (DR)

$\overline{\text{CS}}$ Falling Edge	Device Type Identifier				Device Addresses				Instruction Opcode				DR/Bank Addresses				Data Byte (Sent by X9271 on SO)								$\overline{\text{CS}}$ Rising Edge
	0	1	0	1	0	0	A1	A0	1	0	1	1	RB	RA	P1	P0	D7	D6	D5	D4	D3	D2	D1	D0	
	0	1	0	1	0	0	A1	A0	1	0	1	1	RB	RA	P1	P0	D7	D6	D5	D4	D3	D2	D1	D0	

Write Data Register (DR)

$\overline{\text{CS}}$ Falling Edge	Device Type Identifier				Device Addresses				Instruction Opcode				DR/Bank Addresses				Data Byte (Sent by Host on SI)								$\overline{\text{CS}}$ Rising Edge	HIGH-VOLTAGE WRITE CYCLE
	0	1	0	1	0	0	A1	A0	1	1	0	0	RB	RA	P1	P0	D7	D6	D5	D4	D3	D2	D1	D0		
	0	1	0	1	0	0	A1	A0	1	1	0	0	RB	RA	P1	P0	D7	D6	D5	D4	D3	D2	D1	D0		

Transfer Wiper Counter Register (WCR) to Data Register (DR)

$\overline{\text{CS}}$ Falling Edge	Device Type Identifier				Device Addresses				Instruction Opcode				DR/Bank Addresses				$\overline{\text{CS}}$ Rising Edge	HIGH-VOLTAGE WRITE CYCLE
	0	1	0	1	0	0	A1	A0	1	1	1	0	RB	RA	0	0		
	0	1	0	1	0	0	A1	A0	1	1	1	0	RB	RA	0	0		

ABSOLUTE MAXIMUM RATINGS

Temperature under bias -65°C to +135°C
 Storage temperature..... -65°C to +150°C
 Voltage on SCK, any address input,
 with respect to V_{SS} -1V to +7V
 $\Delta V = |(V_H - V_L)|$ 5.5V
 Lead temperature (soldering, 10 seconds)..... 300°C
 I_W (10 seconds)..... ±6mA
 Pb-Free Reflow Profile see link below
<http://www.intersil.com/pbfree/Pb-FreeReflow.asp>

COMMENT

Stresses above those listed under “Absolute Maximum Ratings” may cause permanent damage to the device. This is a stress rating only; the functional operation of the device (at these or any other conditions above those listed in the operational sections of this specification) is not implied. Exposure to absolute maximum rating conditions for extended periods may affect device reliability.

RECOMMENDED OPERATING CONDITIONS

Temp	Min.	Max.
Commercial	0°C	+70°C
Industrial	-40°C	+85°C

Device	Supply Voltage (V _{CC}) Limits (Note 14)
X9271	5V ± 10%
X9271-2.7	2.7V to 5.5V

ANALOG CHARACTERISTICS (Over recommended industrial operating conditions unless otherwise stated.)

Symbol	Parameter	Limits				Test Conditions
		Min. (Note 18)	Typ.	Max. (Note 18)	Units	
R _{TOTAL}	End to End Resistance		100		kΩ	T version
R _{TOTAL}	End to End Resistance		50		kΩ	U version
	End to End Resistance Tolerance			±20	%	
	Power Rating			50	mW	+25°C, each pot
I _W	Wiper Current			±3	mA	
R _W	Wiper Resistance			300	W	I _W = ± 3mA @ V _{CC} = 3V
R _W	Wiper Resistance			150	W	I _W = ± 3mA @ V _{CC} = 5V
V _{TERM}	Voltage on any R _H or R _L Pin	V _{SS}		V _{CC}	V	V _{SS} = 0V
	Noise		-120		dBV/√Hz	Ref: 1V
	Resolution		0.4		%	
	Absolute Linearity (Note 11)			±1	MI (Note 13)	R _{W(n)(actual)} - R _{W(n)(expected)} (Note 15)
	Relative Linearity (Note 12)			±0.2	MI (Note 13)	R _{W(n+1)} - [R _{W(n)} + MI] (Note 15)
	Temperature Coefficient of R _{TOTAL}		±300		ppm/°C	
	Ratiometric Temp. Coefficient			20	ppm/°C	
C _H /C _L /C _W	Potentiometer Capacitance		10/10/25		pF	See macro model

NOTES:

11. Absolute linearity is used to determine actual wiper voltage versus expected voltage as determined by wiper position when used as a potentiometer.
12. Relative linearity is used to determine actual change in voltage between two successive tap positions when used as a potentiometer. It is a measure of the error in step size.
13. MI = RTOT / 255 or (R_H - R_L) / 255, single pot.
14. During power-up, V_{CC} > V_H, V_L, and V_W.
15. n = 0, 1, 2, ..., 255; m = 0, 1, 2, ..., 254.

D.C. OPERATING CHARACTERISTICS (Over the recommended operating conditions unless otherwise specified.)

Symbol	Parameter	Limits				Test Conditions
		Min. (Note 18)	Typ.	Max. (Note 18)	Units	
I _{CC1}	V _{CC} Supply Current (Active)			400	μA	f _{SCK} = 2.5 MHz, SO = Open, V _{CC} = 6V Other Inputs = V _{SS}
I _{CC2}	V _{CC} Supply Current (Nonvolatile Write)		1	5	mA	f _{SCK} = 2.5MHz, SO = Open, V _{CC} = 6V Other Inputs = V _{SS}
I _{SB}	V _{CC} Current (Standby)			3	μA	SCK = SI = V _{SS} , Addr. = V _{SS} , CS = V _{CC} = 6V
I _{LI}	Input Leakage Current			10	μA	V _{IN} = V _{SS} to V _{CC}
I _{LO}	Output Leakage Current			10	μA	V _{OUT} = V _{SS} to V _{CC}
V _{IH}	Input HIGH Voltage	V _{CC} x 0.7		V _{CC} + 1	V	
V _{IL}	Input LOW Voltage	-1		V _{CC} x 0.3	V	
V _{OL}	Output LOW Voltage			0.4	V	I _{OL} = 3mA
V _{OH}	Output HIGH Voltage	V _{CC} - 0.8			V	I _{OH} = -1mA, V _{CC} ≥ +3V
V _{OH}	Output HIGH Voltage	V _{CC} - 0.4			V	I _{OH} = -0.4mA, V _{CC} ≤ +3V

ENDURANCE AND DATA RETENTION

Parameter	Min. (Note 18)	Units
Minimum Endurance	100,000	Data changes per bit per register
Data Retention	100	Years

CAPACITANCE

Symbol	Test	Max. (Note 18)	Units	Test Conditions
C _{IN/OUT} (Note 16)	Input / Output Capacitance (SI)	8	pF	V _{OUT} = 0V
C _{OUT} (Note 16)	Output Capacitance (SO)	8	pF	V _{OUT} = 0V
C _{IN} (Note 16)	Input Capacitance (A0, CS, WP, HOLD, and SCK)	6	pF	V _{IN} = 0V

POWER-UP TIMING

Symbol	Parameter	Min. (Note 18)	Max. (Note 18)	Units
t _r V _{CC} (Note 16)	V _{CC} Power-up Rate	0.2	50	V/ms
t _{PUR} (Note 17)	Power-up to Initiation of Read Operation		1	ms
t _{PW} (Note 17)	Power-up to Initiation of Write Operation		50	ms

A.C. TEST CONDITIONS

Input Pulse Levels	V _{CC} x 0.1 to V _{CC} x 0.9
Input Rise and Fall Times	10ns
Input and Output Timing Level	V _{CC} x 0.5

NOTES:

16. This parameter is not 100% tested.
17. t_{PUR} and t_{PW} are the delays required from the time the (last) power supply (V_{CC}-) is stable until the specific instruction can be issued. These parameters are periodically sampled and are not 100% tested.
18. Compliance to datasheet limits is assured by one or more methods: production test, characterization and/or design.

EQUIVALENT A.C. LOAD CIRCUIT

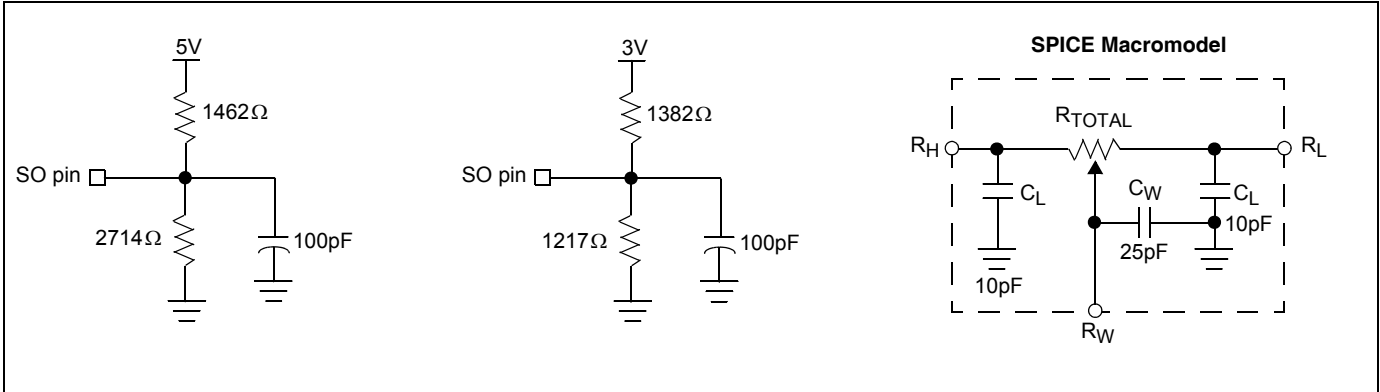

AC TIMING

Symbol	Parameter	Min.	Max.	Units
f_{SCK}	SSI/SPI Clock Frequency		2.5	MHz
t_{CYC}	SSI/SPI Clock Cycle Time	500		ns
t_{WH}	SSI/SPI Clock High Time	200		ns
t_{WL}	SSI/SPI Clock Low Time	200		ns
t_{LEAD}	Lead Time	250		ns
t_{LAG}	Lag Time	250		ns
t_{SU}	SI, SCK, \overline{HOLD} and \overline{CS} Input Setup Time	50		ns
t_H	SI, SCK, \overline{HOLD} and \overline{CS} Input Hold Time	50		ns
t_{RI}	SI, SCK, \overline{HOLD} and \overline{CS} Input Rise Time		2	μs
t_{FI}	SI, SCK, \overline{HOLD} and \overline{CS} Input Fall Time		2	μs
t_{DIS}	SO Output Disable Time	0	250	ns
t_V	SO Output Valid Time		200	ns
t_{HO}	SO Output Hold Time	0		ns
t_{RO}	SO Output Rise Time		100	ns
t_{FO}	SO Output Fall Time		100	ns
t_{HOLD}	\overline{HOLD} Time	400		ns
t_{HSU}	\overline{HOLD} Setup Time	100		ns
t_{HH}	\overline{HOLD} Hold Time	100		ns
t_{HZ}	\overline{HOLD} Low to Output in High Z		100	ns
t_{LZ}	\overline{HOLD} High to Output in Low Z		100	ns
T_I	Noise Suppression Time Constant at SI, SCK, \overline{HOLD} and \overline{CS} Inputs		10	ns
t_{CS}	\overline{CS} Deselect Time	2		μs
t_{WPASU}	\overline{WP} , A0 Setup Time	0		ns
t_{WPAH}	\overline{WP} , A0 Hold Time	0		ns



HIGH-VOLTAGE WRITE CYCLE TIMING

Symbol	Parameter	Typ.	Max.	Units
t_{WR}	High-voltage Write Cycle Time (Store Instructions)	5	10	ms

XDCP TIMING

Symbol	Parameter	Min.	Max.	Units
t_{WRPO}	Wiper Response Time After Third (Last) Power Supply is Stable	5	10	μ s
t_{WRL}	Wiper Response Time After Instruction Issued (All Load Instructions)	5	10	μ s

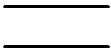
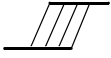
SYMBOL TABLE

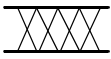
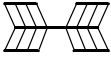
WAVEFORM	INPUTS	OUTPUTS
	Must be steady	Will be steady
	May change from Low to High	Will change from Low to High
	May change from High to Low	Will change from High to Low
	Don't Care: Changes Allowed	Changing: State Not Known
	N/A	Center Line is High Impedance

TIMING DIAGRAMS

Input Timing

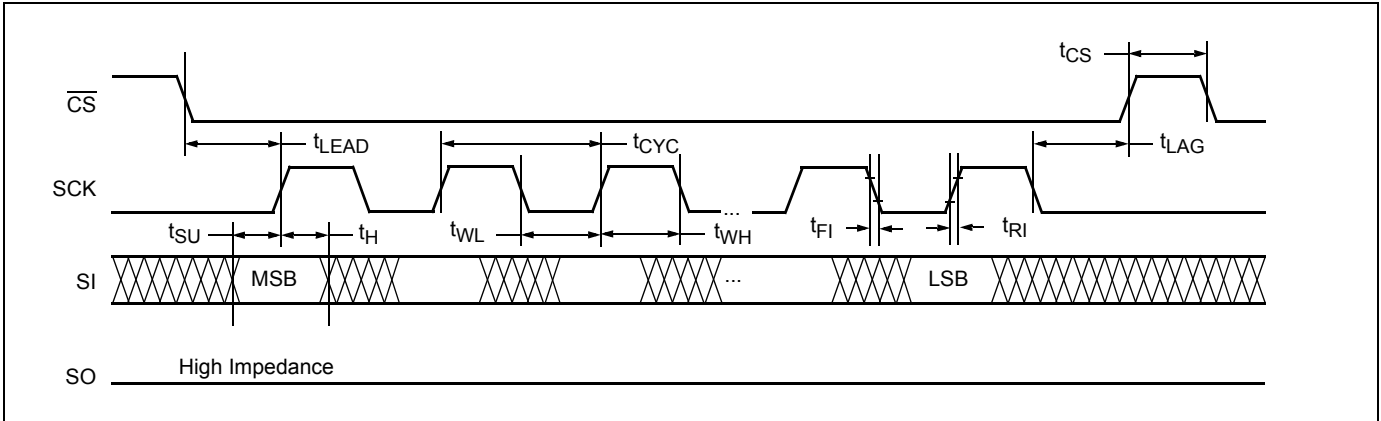

Output Timing

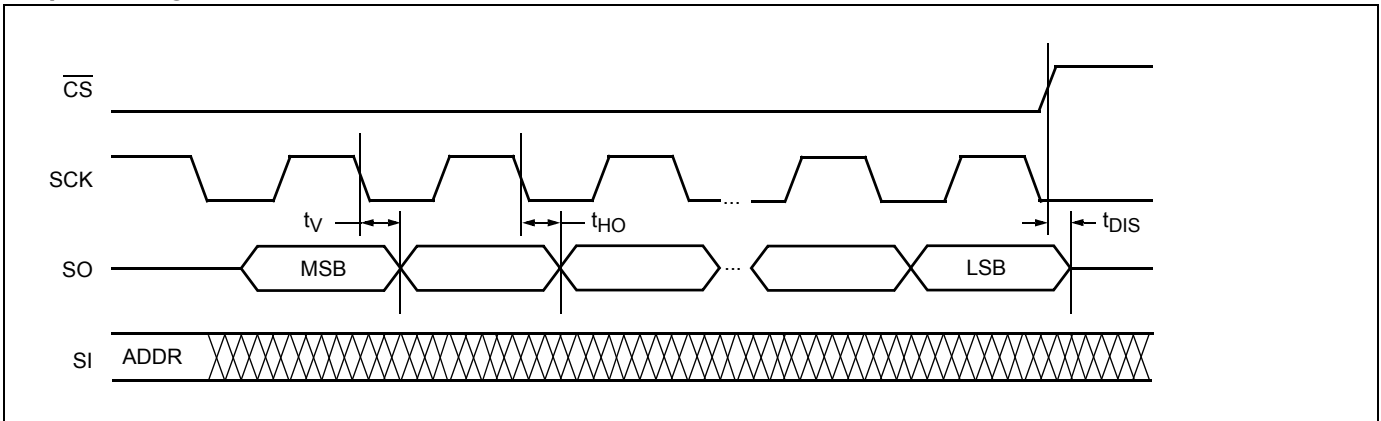

Hold Timing

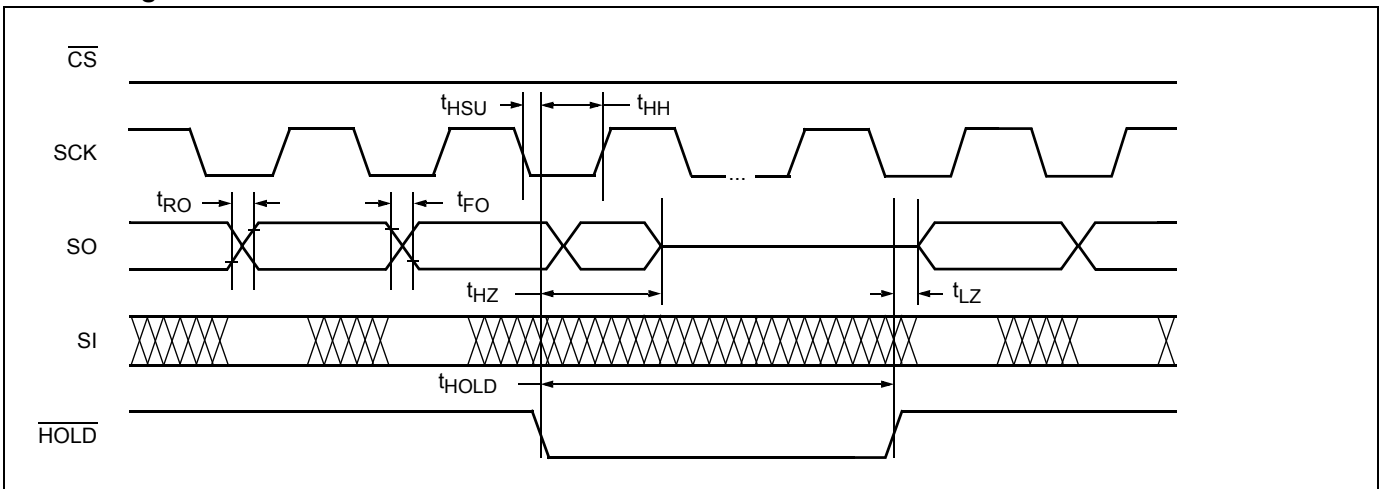

XDCP Timing (for All Load Instructions)

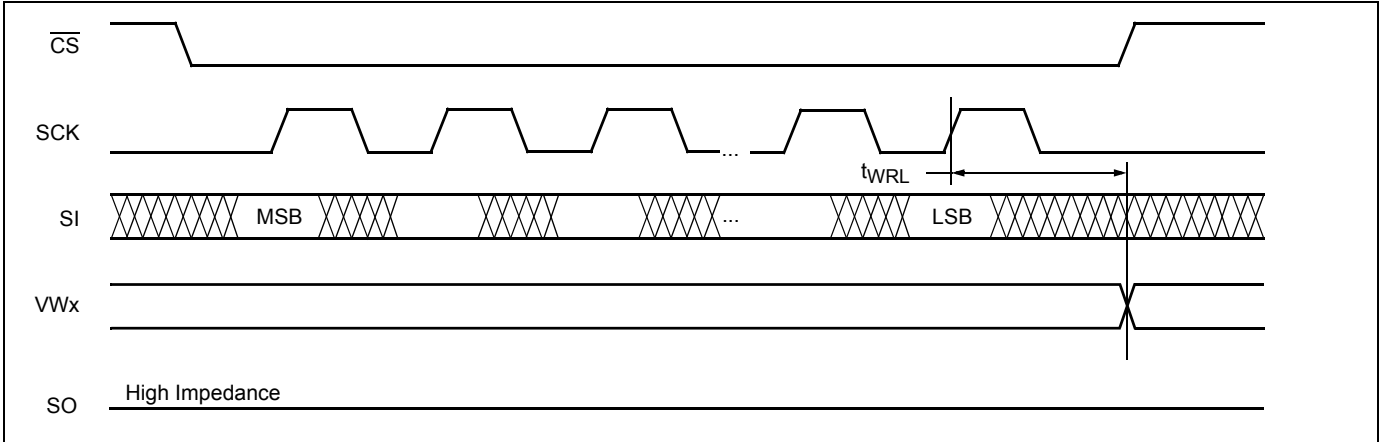

Write Protect and Device Address Pins Timing

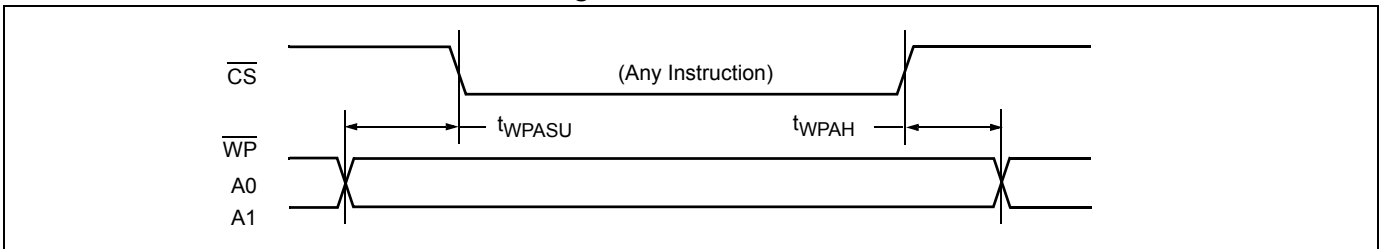

APPLICATIONS INFORMATION

Basic Configurations of Electronic Potentiometers

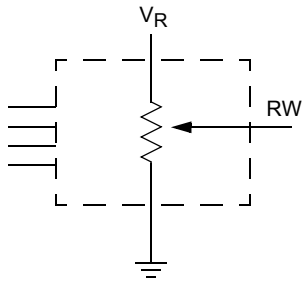

3-terminal Potentiometer;
Variable Voltage Divider

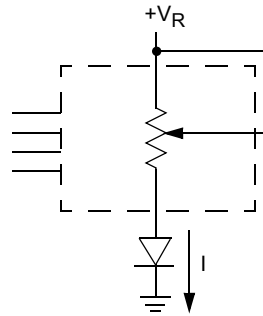

2-terminal Variable Resistor;
Variable Current

Application Circuits

Noninverting Amplifier

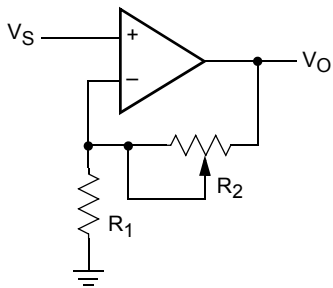

$$V_O = (1 + R_2/R_1)V_S$$

Voltage Regulator

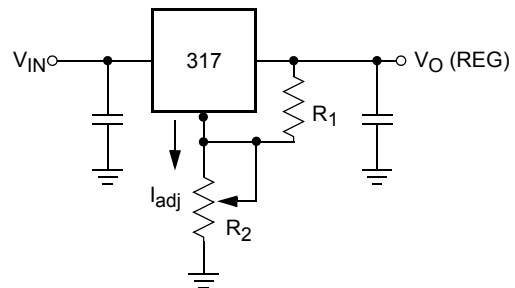

$$V_O (\text{REG}) = 1.25V (1 + R_2/R_1) + I_{\text{adj}} R_2$$

Offset Voltage Adjustment

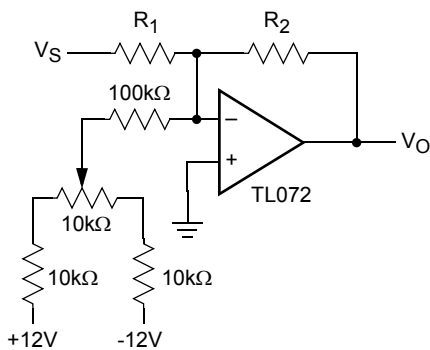

Comparator with Hysteresis

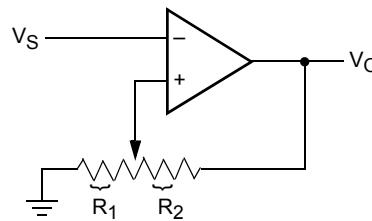

$$V_{UL} = \{R_1/(R_1 + R_2)\} V_O(\text{max})$$

$$V_{RL} = \{R_1/(R_1 + R_2)\} V_O(\text{min})$$

Application Circuits (continued)

Attenuator

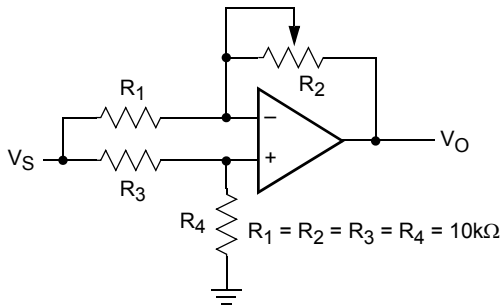

$$V_O = G V_S$$

$$-1/2 \leq G \leq +1/2$$

Filter

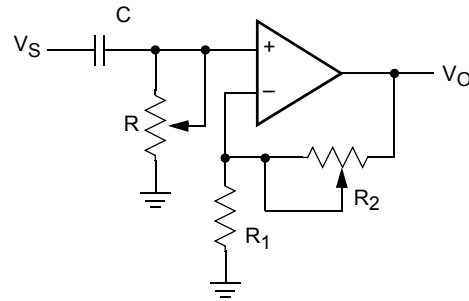

$$G_O = 1 + R_2/R_1$$

$$f_c = 1/(2\pi RC)$$

Inverting Amplifier

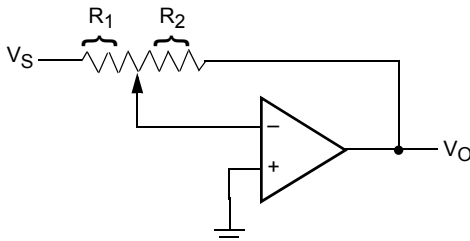

$$V_O = G V_S$$

$$G = -R_2/R_1$$

Equivalent L-R Circuit

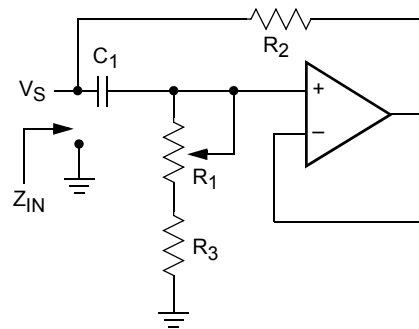

$$Z_{IN} = R_2 + s R_2 (R_1 + R_3) C_1 = R_2 + s L_{eq}$$

$$(R_1 + R_3) \gg R_2$$

Function Generator

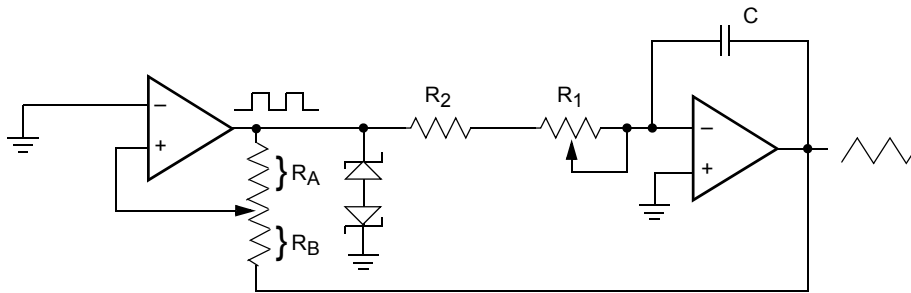

$$\text{Frequency} \propto R_1, R_2, C$$

$$\text{Amplitude} \propto R_A, R_B$$

All Intersil U.S. products are manufactured, assembled and tested utilizing ISO9000 quality systems.
Intersil Corporation's quality certifications can be viewed at www.intersil.com/design/quality

Intersil products are sold by description only. Intersil Corporation reserves the right to make changes in circuit design, software and/or specifications at any time without notice. Accordingly, the reader is cautioned to verify that data sheets are current before placing orders. Information furnished by Intersil is believed to be accurate and reliable. However, no responsibility is assumed by Intersil or its subsidiaries for its use; nor for any infringements of patents or other rights of third parties which may result from its use. No license is granted by implication or otherwise under any patent or patent rights of Intersil or its subsidiaries.

For information regarding Intersil Corporation and its products, see www.intersil.com

Package Outline Drawing

M14.173

14 LEAD THIN SHRINK SMALL OUTLINE PACKAGE (TSSOP)

Rev 3, 10/09

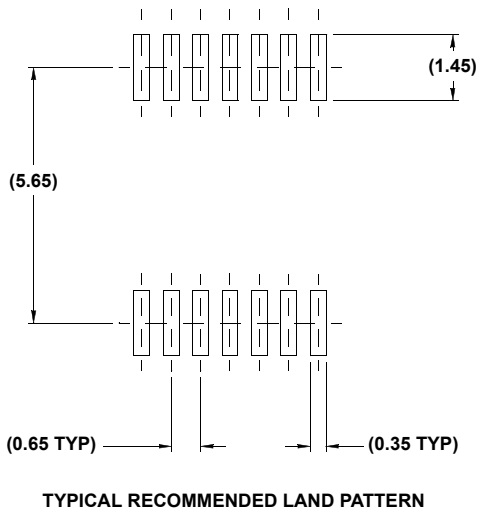
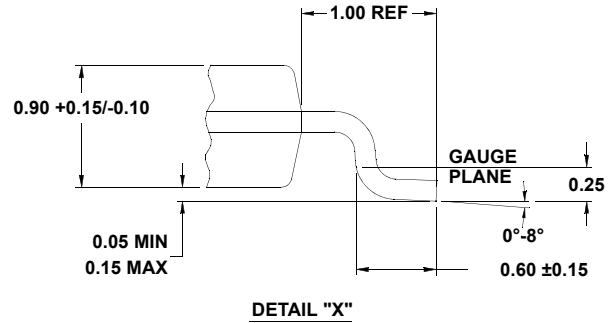
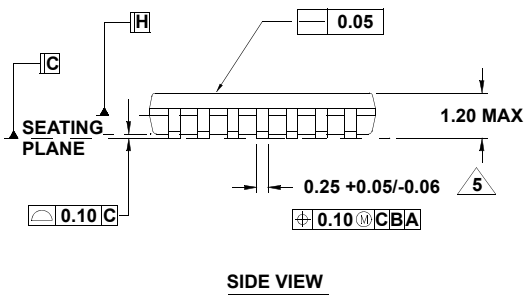
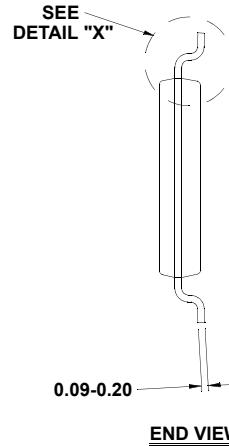
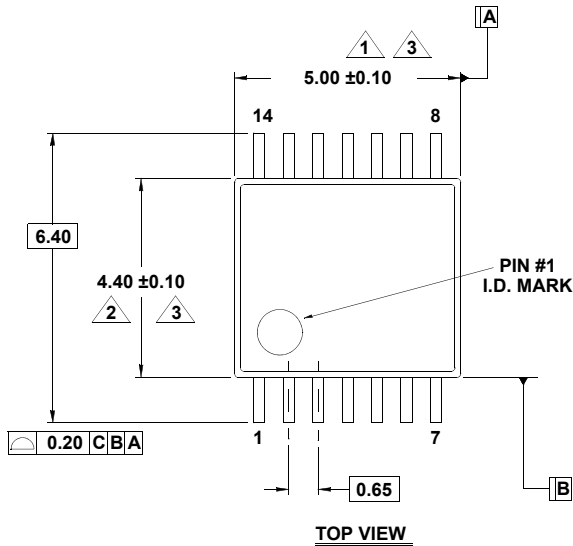

NOTES:

1. Dimension does not include mold flash, protrusions or gate burrs. Mold flash, protrusions or gate burrs shall not exceed 0.15 per side.
2. Dimension does not include interlead flash or protrusion. Interlead flash or protrusion shall not exceed 0.25 per side.
3. Dimensions are measured at datum plane H.
4. Dimensioning and tolerancing per ASME Y14.5M-1994.
5. Dimension does not include dambar protrusion. Allowable protrusion shall be 0.80mm total in excess of dimension at maximum material condition. Minimum space between protrusion and adjacent lead is 0.07mm.
6. Dimension in () are for reference only.
7. Conforms to JEDEC MO-153, variation AB-1.