

# 12-bit, 125kSPS Low-power ADCs with Single-ended and Differential Inputs and Multiple Input Channels

## ISL26310, ISL26311, ISL26312, ISL26313, ISL26314, ISL26315, ISL26319

The ISL26310/11/12/13/14/15/19 family of sampling SAR-type ADCs feature excellent linearity over supply and temperature variations, and offer versions with 1-, 2-, 4- and 8-channel single-ended inputs, and 1-, 2- and 4-channel differential inputs.

A proprietary input multiplexer and combination buffer amplifier reduces the input drive requirements, resulting in lower cost and reduced board space. Specified measurement accuracy is maintained with input signals up to VDD.

Members of the ISL26310/11/12/13/14/15/19 family of Low-Power ADCs offer pinout intercompatibility, differing only in the analog inputs, to support quick replication of proven layouts across multiple design platforms.

The serial digital interface is SPI compatible and is easily interfaced to popular FPGAs and microcontrollers. Power consumption is limited to 11mW at a sampling rate of 125kSPS, and an operating current of just 8µA typical between conversions, when configured for Auto Powerdown mode.

The ISL26310/11/12/13/14/15/19 feature up to 5kV Human Body Model ESD survivability and are available in the popular SOIC and TSSOP packages. Performance is specified for operation over the full industrial temperature range (-40°C to +125°C).

## Features

- Pin-compatible Family Allows Easy Design Upgrades
- Excellent Differential Non-Linearity (0.7LSB max)
- Low THD: -86dB (typ)
- Simple SPI-compatible Serial Digital Interface
- Low 2.2mA Operating Current
- Power-down Current between Conversions 8µA (typ)
- +5.25V to +2.7V Supply
- Excellent ESD Survivability: 5kV HBM, 350V MM, 2kV CDM

## Applications

- Industrial Process Control
- Energy Measurement
- Multichannel Data Acquisition Systems
- Pressure Sensors
- Flow Controllers

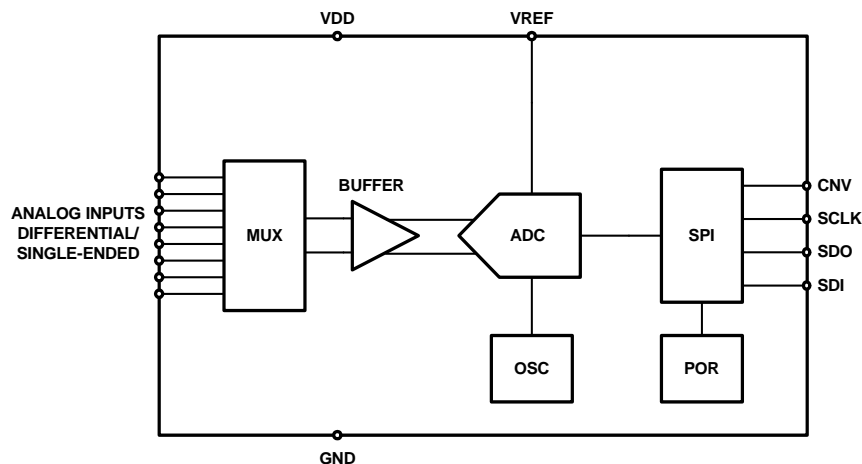
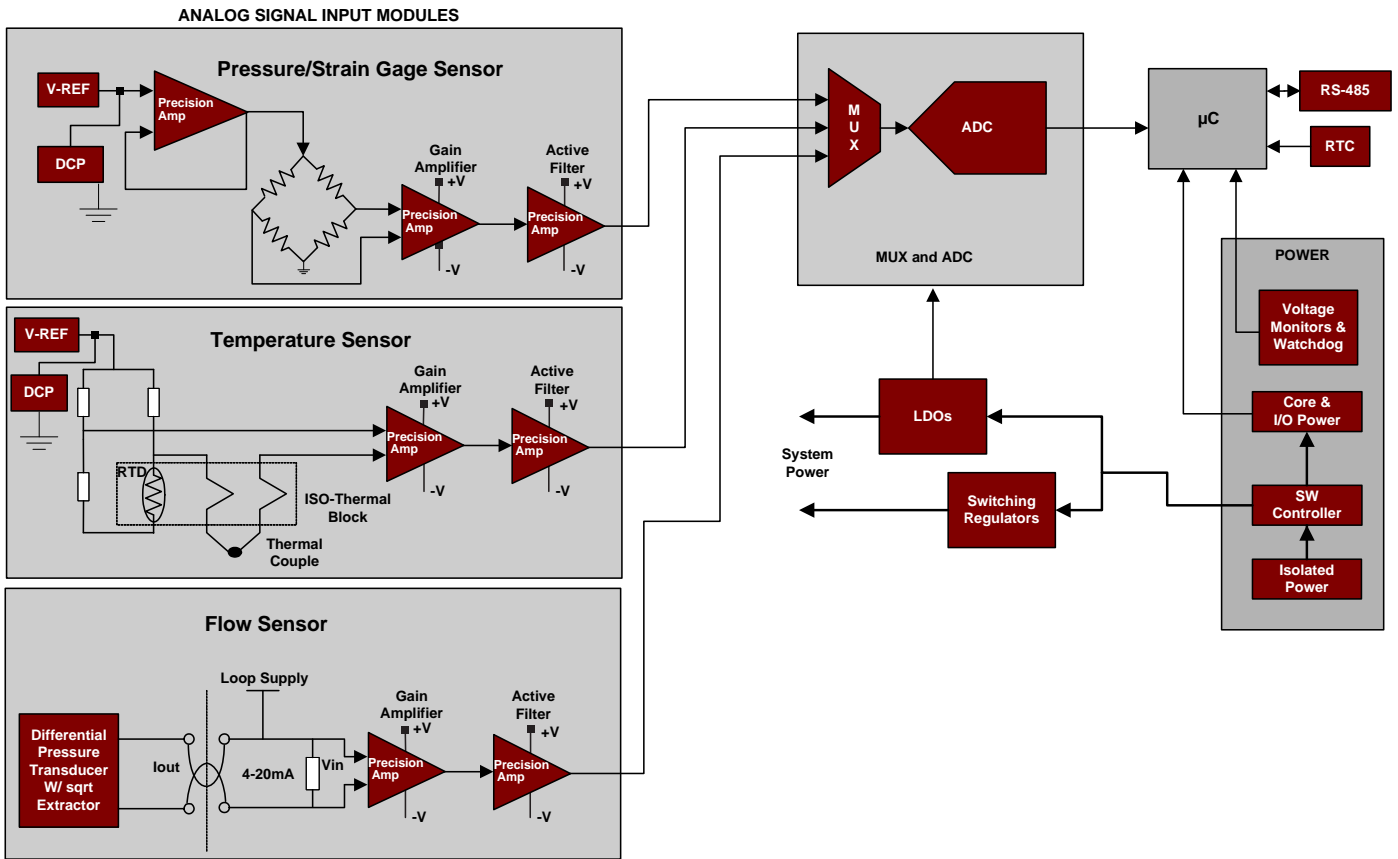

FIGURE 1. FUNCTIONAL BLOCK DIAGRAM

## Application Block Diagram



## Pin-Compatible Family

MODEL	RESOLUTION (Bits)	SPEED (kHz)	ANALOG INPUT	INPUT CHANNELS
ISL26310	12	125	Differential	1
ISL26311	12	125	Single-Ended	1
ISL26312	12	125	Differential	2
ISL26313	12	125	Single-Ended	2
ISL26314	12	125	Differential	4
ISL26315	12	125	Single-Ended	4
ISL26319	12	125	Single-Ended	8
ISL26320	12	250	Differential	1
ISL26321	12	250	Single-Ended	1
ISL26322	12	250	Differential	2
ISL26323	12	250	Single-Ended	2
ISL26324	12	250	Differential	4
ISL26325	12	250	Single-Ended	4
ISL26329	12	250	Single-Ended	8

## Ordering Information

PART NUMBER (Notes 1, 2, 3)	PART MARKING	DESCRIPTION				TEMP. RANGE (°C)	PACKAGE (Pb-Free)	PKG DWG #
		RESOLUTION (Bits)	SPEED (kHz)	INPUT (SE/DIFF)	INPUT CHANNELS			
ISL26310FBZ	26310 FBZ	12	125	Diff	1	-40 to +125	8 Ld SOIC	M8.15
ISL26311FBZ	26311 FBZ	12	125	SE	1	-40 to +125	8 Ld SOIC	M8.15
ISL26312FVZ	26312 FVZ	12	125	Diff	2	-40 to +125	16 Ld TSSOP	M16.173
ISL26313FBZ	26313 FBZ	12	125	SE	2	-40 to +125	8 Ld SOIC	M8.15
ISL26314FVZ	26314 FVZ	12	125	Diff	4	-40 to +125	16 Ld TSSOP	M16.173
ISL26315FVZ	26315 FVZ	12	125	SE	4	-40 to +125	16 Ld TSSOP	M16.173
ISL26319FVZ	26319 FVZ	12	125	SE	8	-40 to +125	16 Ld TSSOP	M16.173

**NOTES:**

1. Add "-T\*" suffix for tape and reel. Please refer to [TB347](#) for details on reel specifications.
2. These Intersil Pb-free plastic packaged products employ special Pb-free material sets, molding compounds/die attach materials, and 100% matte tin plate plus anneal (e3 termination finish, which is RoHS compliant and compatible with both SnPb and Pb-free soldering operations). Intersil Pb-free products are MSL classified at Pb-free peak reflow temperatures that meet or exceed the Pb-free requirements of IPC/JEDEC J STD-020.
3. For Moisture Sensitivity Level (MSL), please see device information page for [ISL26310](#), [ISL26311](#), [ISL26312](#), [ISL26313](#), [ISL26314](#), [ISL26315](#), [ISL26319](#). For more information on MSL please see techbrief [TB363](#).

**Pin Configurations**

ISL26310  
(8 LD SOIC)  
TOP VIEW

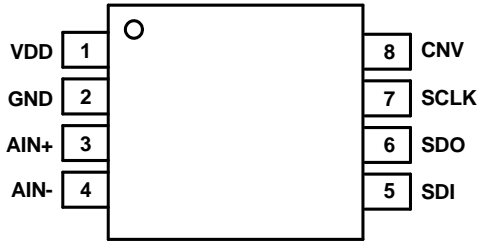

ISL26311  
(8 LD SOIC)  
TOP VIEW

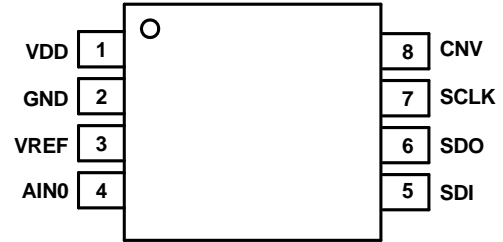

ISL26313  
(8 LD SOIC)  
TOP VIEW

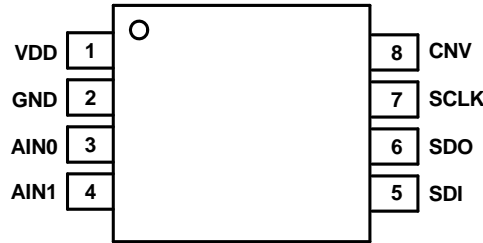

ISL26312  
(16 LD TSSOP)  
TOP VIEW

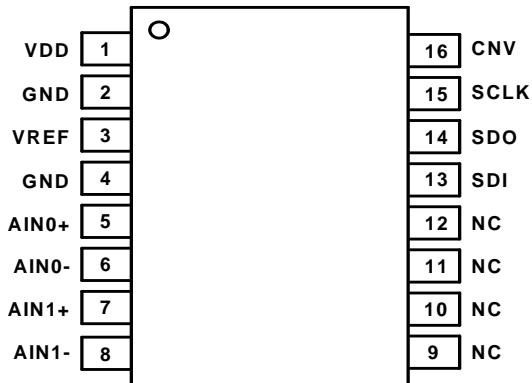

ISL26314  
(16 LD TSSOP)  
TOP VIEW

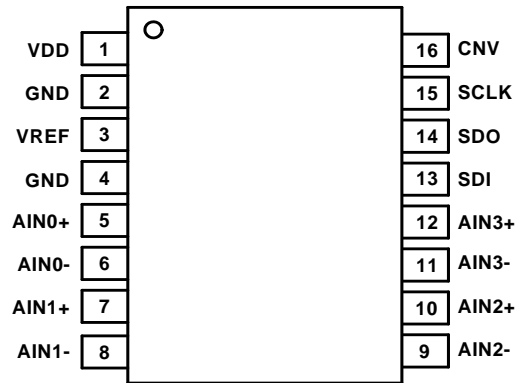

ISL26315  
(16 LD TSSOP)  
TOP VIEW

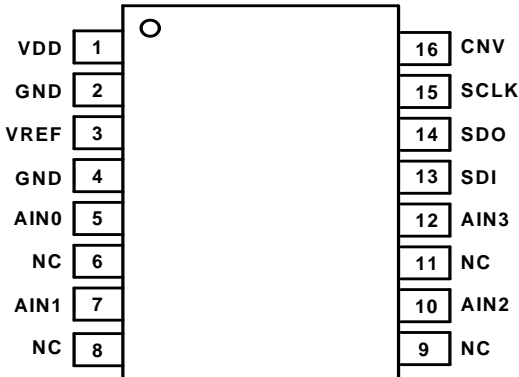

ISL26319  
(16 LD TSSOP)  
TOP VIEW

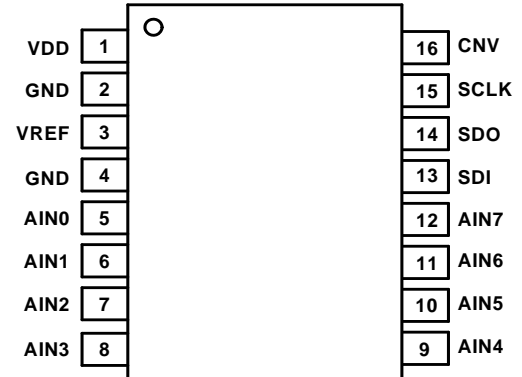

## Pin Descriptions

PIN NAME	PIN NUMBER							DESCRIPTION
	ISL26310	ISL26311	ISL26312	ISL26313	ISL26314	ISL26315	ISL26319	
VDD	1	1	1	1	1	1	1	Positive Supply Voltage
GND	2	2	2, 4	2	2, 4	2, 4	2, 4	Ground
VREF	-	3	3	-	3	3	3	Reference Voltage Input
AIN0+	-	-	5	-	5	-	-	Differential Analog Input, Positive
AIN0-	-	-	6	-	6	-	-	Differential Analog Input, Negative
AIN1+	-	-	7	-	7	-	-	Differential Analog Input, Positive
AIN1-	-	-	8	-	8	-	-	Differential Analog Input, Negative
AIN2+	-	-	-	-	10	-	-	Differential Analog Input, Positive
AIN2-	-	-	-	-	9	-	-	Differential Analog Input, Negative
AIN3+	-	-	-	-	12	-	-	Differential Analog Input, Positive
AIN3-	-	-	-	-	11	-	-	Differential Analog Input, Negative
AIN0	-	4	-	3	-	5	5	Single-Ended Analog Input
AIN1	-	-	-	4	-	7	6	Single-Ended Analog Input
AIN2	-	-	-	-	-	10	7	Single-Ended Analog Input
AIN3	-	-	-	-	-	12	8	Single-Ended Analog Input
AIN4	-	-	-	-	-	-	9	Single-Ended Analog Input
AIN5	-	-	-	-	-	-	10	Single-Ended Analog Input
AIN6	-	-	-	-	-	-	11	Single-Ended Analog Input
AIN7	-	-	-	-	-	-	12	Single-Ended Analog Input
SDI	5	5	13	5	13	13	13	Serial Interface Data Input
SDO	6	6	14	6	14	14	14	Serial Interface Data Output
SCLK	7	7	15	7	15	15	15	Serial Interface Clock Input
CNV	8	8	16	8	16	16	16	Conversion Control Input
NC	-	-	9, 10, 11, 12	-	-	6, 8, 9, 11	-	No Connect
AIN+	3	-	-	-	-	-	-	Differential Analog Input, Positive
AIN-	4	-	-	-	-	-	-	Differential Analog Input, Negative

# ISL26310, ISL26311, ISL26312, ISL26313, ISL26314, ISL26315, ISL26319

## Absolute Maximum Ratings

AIN+, AIN-, VREF .....	GND-0.3 to V <sub>DD</sub> +0.3V
Digital Inputs .....	GND-0.3 to V <sub>DD</sub> +0.3V
VDD .....	-0.3 to 6V
GND .....	GND-0.3 to +0.3V
ESD Rating	
Human Body Model (Per MIL-STD-883 Method 3015.7) .....	5000V
Machine Model (Per JESD22-A115) .....	350V
Charged Device Model (Per JESD22-C101) .....	2000V
Latch-up (Tested per JESD-78B; Class 2, Level A) .....	100mA

## Thermal Information

Thermal Resistance (Typical)	$\theta_{JA}$ (°C/W)	$\theta_{JC}$ (°C/W)
8 Ld SOIC (Notes 4, 5) .....	98	48
16 Ld TSSOP (Notes 4, 5) .....	92	29
Maximum Power Dissipation .....	80mW	
Maximum Junction Temperature .....	+150°C	
Maximum Storage Temperature Range .....	-65°C to +150°C	
Pb-Free Reflow Profile .....	see link below	
	<a href="http://www.intersil.com/pbfree/Pb-FreeReflow.asp">http://www.intersil.com/pbfree/Pb-FreeReflow.asp</a>	

## Operating Conditions

Temperature Range .....	-40°C to +125°C
V <sub>DD</sub> to GND .....	2.7V to +5.25V

**CAUTION:** Do not operate at or near the maximum ratings listed for extended periods of time. Exposure to such conditions may adversely impact product reliability and result in failures not covered by warranty.

### NOTES:

- $\theta_{JA}$  is measured with the component mounted on a high effective thermal conductivity test board in free air. See Tech Brief [TB379](#) for details.
- For  $\theta_{JC}$ , the “case temp” location is taken at the package top center.

**Electrical Specifications** V<sub>REF</sub> = V<sub>DD</sub> V, V<sub>DD</sub> = 2.7V to 5V, V<sub>CM</sub> = V<sub>DD</sub>/2, SCLK = 20MHz and T<sub>A</sub> = -40°C to +125°C (typical performance at +25°C), unless otherwise specified. **Boldface limits apply over the operating temperature range, -40°C to +125°C.**

SYMBOL	PARAMETER	TEST LEVEL OR NOTES	MIN (Note 6)	TYP	MAX (Note 6)	UNITS
<b>ANALOG INPUTS</b>						
	Number of Input Channels	ISL26310, ISL26311		1		
		ISL26312, ISL26313		2		
		ISL26314, ISL26315		4		
		ISL26319		8		
	Input Voltage Range	Differential Inputs (AINX+ - AINX-) is -V <sub>REF</sub> (Min) and +V <sub>REF</sub> (Max)	<b>0</b>		<b>V<sub>REF</sub></b>	V
		AINX, Single-Ended Inputs	<b>0</b>		<b>V<sub>REF</sub></b>	V
	Common Mode Input Voltage Range	Differential Inputs	<b>V<sub>REF</sub>/2 - 0.2</b>	V <sub>REF</sub> /2	<b>V<sub>REF</sub>/2 + 0.2</b>	V
	Average Input Current			2.5		µA
C <sub>IN</sub>	Input Capacitance			4		pF
	Channel-Channel Crosstalk	f <sub>IN</sub> = 100kHz V <sub>IN</sub> = FS, other channels = 0V		-86		dB
<b>VOLTAGE REFERENCE</b>						
V <sub>REFEX</sub>	External Reference Input Voltage Range		<b>2</b>	2.5	V <sub>DD</sub>	V
I <sub>REFIN</sub>	Average Input Current			100	120	µA
C <sub>REFIN</sub>	Effective Input Capacitance			10		pF
<b>DC ACCURACY</b>						
	Resolution (No Missing Codes)		<b>12</b>			Bits
DNL	Differential Nonlinearity Error		<b>-0.7</b>		<b>+0.7</b>	LSB
INL	Integral Nonlinearity Error		<b>-0.7</b>		<b>+0.7</b>	LSB
	Gain Error		<b>-6</b>		<b>6</b>	LSB
	Gain Error Matching		<b>-2</b>		<b>2</b>	LSB
	Offset Error		<b>-6</b>		<b>6</b>	LSB
	Offset Error Matching		<b>-2</b>		<b>2</b>	LSB

# ISL26310, ISL26311, ISL26312, ISL26313, ISL26314, ISL26315, ISL26319

**Electrical Specifications** VREF = VDD V, VDD = 2.7V to 5V, VCM = VDD/2, SCLK = 20MHz and TA = -40 °C to +125 °C (typical performance at +25 °C), unless otherwise specified. **Boldface limits apply over the operating temperature range, -40 °C to +125 °C. (Continued)**

SYMBOL	PARAMETER	TEST LEVEL OR NOTES	MIN (Note 6)	TYP	MAX (Note 6)	UNITS
PSRR	Power Supply Rejection Ratio			70		dB
<b>DYNAMIC PERFORMANCE</b>						
SNR	Signal-to-Noise Notes: VIN = FS-0.1dB, fIN = 10kHz	Differential Inputs		73.4		dB
		Single-Ended Inputs		73.4		dB
SINAD	Signal-to-Noise + Distortion Notes: VIN = FS-0.1dB, fIN = 10kHz	Differential Inputs		73.1		dB
		Single-Ended Inputs		73.1		dB
THD	Total Harmonic Distortion Notes: VIN = FS-0.1dB, fIN = 10kHz	Differential Inputs		-86		dB
		Single-Ended Inputs		-86		dB
SFDR	Spurious-free Dynamic Range Notes: VIN = FS-0.1dB	fIN = 20kHz		96		dB
BW	-3dB Input Bandwidth			2.5		MHz
tAD	Sampling Aperture Delay			12		ns
tjit	Sampling Aperture Jitter			25		ps
<b>POWER SUPPLY REQUIREMENTS</b>						
VDD	Supply Voltage		<b>2.7</b>		<b>5.25</b>	V
IDD	Supply Current			2.2	<b>3</b>	mA
PD	Power Consumption	Normal Operation		11	<b>15</b>	mW
IPD	Power-down Current	Auto Power-Down Mode		8	<b>50</b>	µA
Istby	Standby Mode Current	Auto Sleep Mode		0.4		mA
<b>DIGITAL INPUTS</b>						
VIH			<b>0.7 VDD</b>			V
VIL					<b>0.2 VDD</b>	V
VOH	I <sub>OH</sub> = -1mA		<b>VDD-0.4</b>			V
VOL	I <sub>OL</sub> = 1mA				<b>0.2 VDD</b>	V
I <sub>IH</sub> , I <sub>IL</sub>	Input Leakage Current		<b>-100</b>		<b>100</b>	nA
	Serial Clock Frequency				<b>20</b>	MHz
<b>TIMING SPECIFICATIONS (Note 7)</b>						
tSCLK	SCLK Period (in RAC Mode)		<b>50</b>			ns
tSCLK	SCLK Period (in RSC, RDC Modes)		<b>50</b>		<b>200</b>	ns
tDATA	Safe Data Transfer Time After Conversion State Begins				<b>3.2</b>	µs
tCSB_SCLK	CSB Falling Low to SCLK Rising Edge		<b>40</b>			ns
tSDI_SU	SDI Setup Time with Respect to Positive Edge of SCLK		<b>10</b>			ns
tSDI_H	SDI Hold Time with Respect to Positive Edge of SCLK		<b>10</b>			ns
tSDO_V	SDOUT Valid Time with Respect to Negative Edge of SCLK				<b>25</b>	ns
tSDOZ_D	SDOUT to High Impedance State After CNV Rising Edge (or last SCLK falling edge)	Note 8		85		ns
tACQ	Acquisition Time when Fully Powered Up		<b>800</b>			ns
tACQ	Acquisition Time in Auto Sleep Mode		<b>2.1</b>			µs

# ISL26310, ISL26311, ISL26312, ISL26313, ISL26314, ISL26315, ISL26319

**Electrical Specifications** VREF = VDD V, VDD = 2.7V to 5V, VCM = VDD/2, SCLK = 20MHz and TA = -40 °C to +125 °C (typical performance at +25 °C), unless otherwise specified. **Boldface limits apply over the operating temperature range, -40 °C to +125 °C. (Continued)**

SYMBOL	PARAMETER	TEST LEVEL OR NOTES	MIN (Note 6)	TYP	MAX (Note 6)	UNITS
t <sub>ACQ</sub>	Acquisition time in Auto Power Down Mode		<b>150</b>			µs
t <sub>SCLKH</sub>	SCLK High Time		<b>20</b>			ns
t <sub>SCLKL</sub>	SCLK Low Time		<b>20</b>			ns
t <sub>CNV</sub>	CNV Pulse Width		<b>100</b>			ns

**NOTES:**

6. Compliance to datasheet limits is assured by one or more methods: production test, characterization and/or design.
7. The device may become nonresponsive if the minimum acquisition times are not met in their respective modes, requiring a power cycle to restore normal operation.
8. Transition time to high impedance state is dominated by RC loading on the SDOUT pin. Specified value is measured using equivalent loading shown in Figure 2.

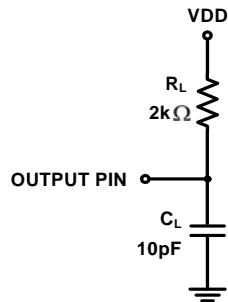

**FIGURE 2. EQUIVALENT LOAD CIRCUIT FOR DIGITAL OUTPUT TESTING**



### Typical Performance Characteristics

unless otherwise specified.

$T_A = +25^\circ\text{C}$ ,  $V_{DD} = 5\text{V}$ ,  $V_{REF} = 5\text{V}$ ,  $f_{\text{SAMPLE}} = 125\text{kHz}$ ,  $f_{\text{SCLK}} = 20\text{MHz}$ ,

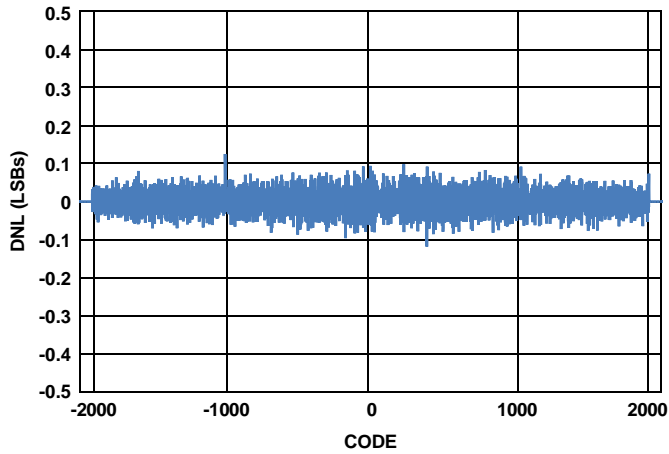

FIGURE 3. DIFFERENTIAL NONLINEARITY (DNL) vs CODE

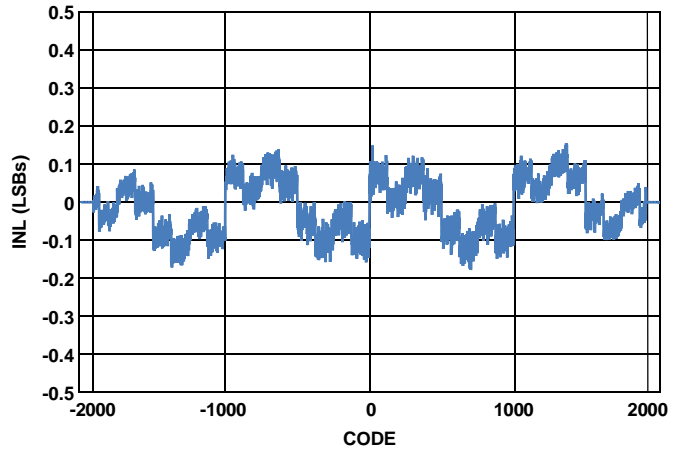

FIGURE 4. INTEGRAL NONLINEARITY (INL) vs CODE

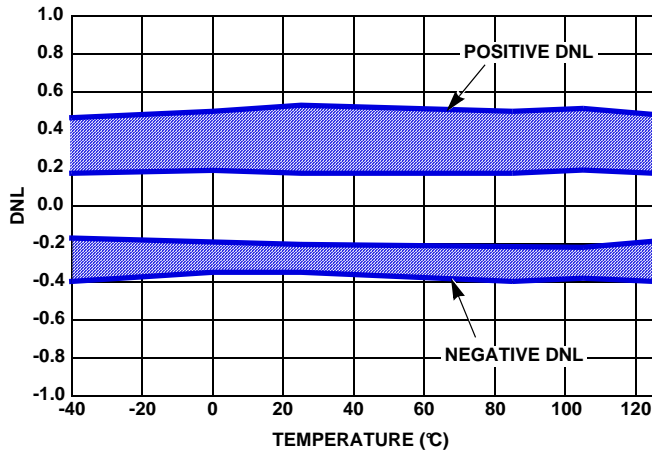

FIGURE 5. DNL DISTRIBUTION vs TEMPERATURE

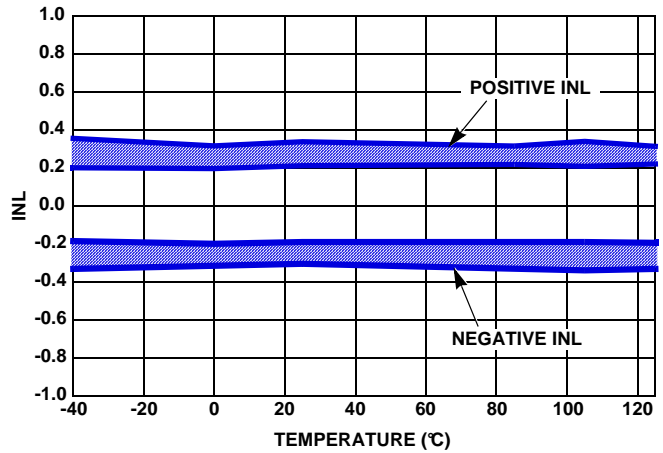

FIGURE 6. INL DISTRIBUTION vs TEMPERATURE

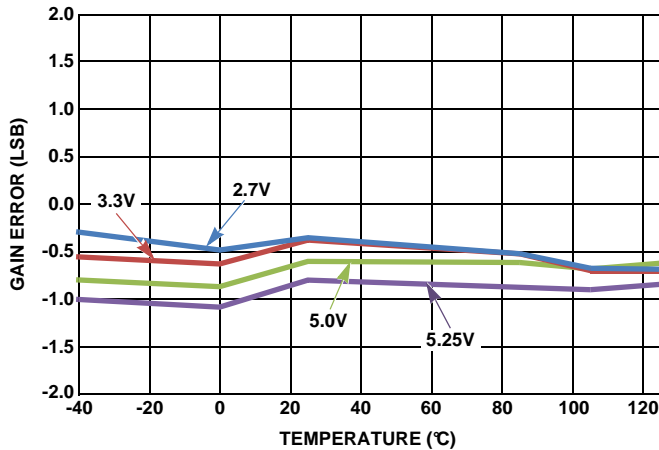

FIGURE 7. GAIN ERROR vs SUPPLY VOLTAGE AND TEMPERATURE

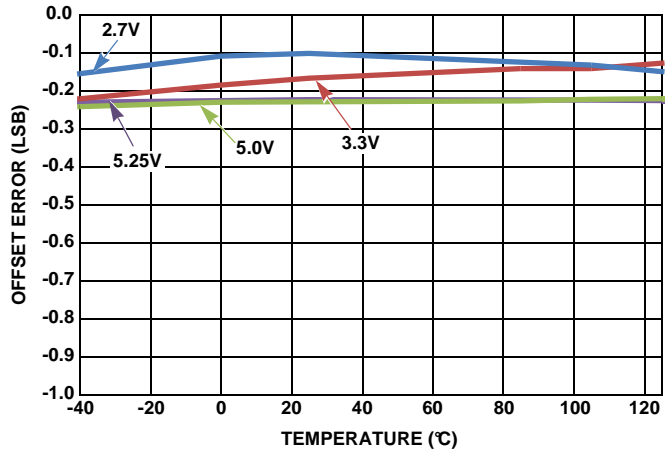

FIGURE 8. OFFSET ERROR vs SUPPLY VOLTAGE AND TEMPERATURE

**Typical Performance Characteristics**

unless otherwise specified. (Continued)

$T_A = +25^\circ\text{C}$ ,  $V_{DD} = 5\text{V}$ ,  $V_{REF} = 5\text{V}$ ,  $f_{\text{SAMPLE}} = 125\text{kHz}$ ,  $f_{\text{SCLK}} = 20\text{MHz}$

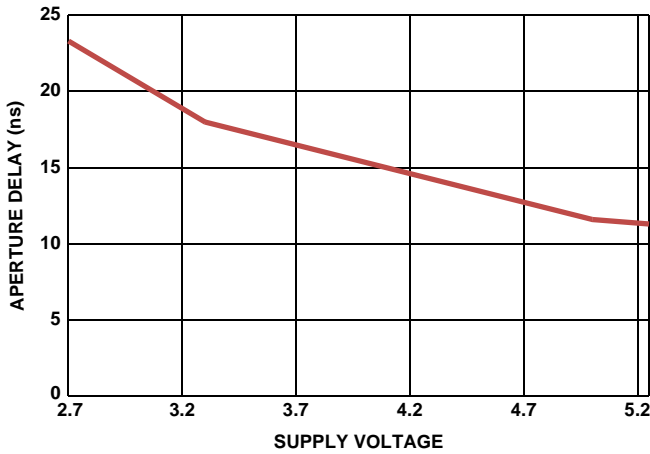

FIGURE 9. APERTURE DELAY vs SUPPLY VOLTAGE

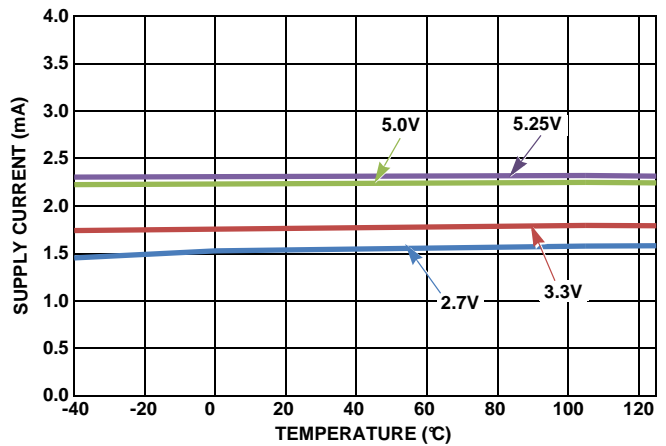

FIGURE 10. SUPPLY CURRENT vs VOLTAGE AND TEMPERATURE

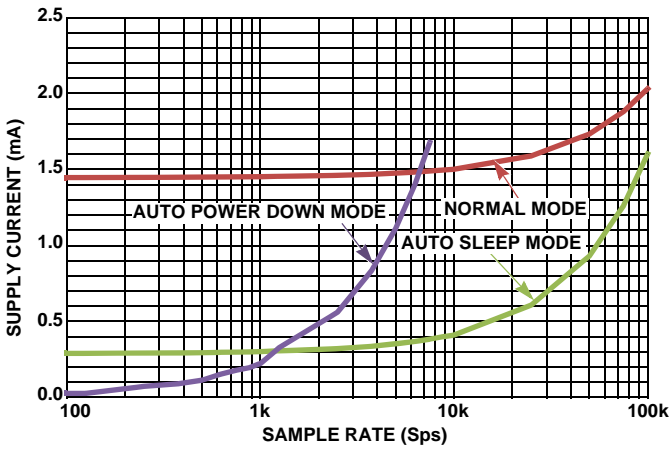

FIGURE 11. SUPPLY CURRENT vs SAMPLING RATE ( $V_{DD} = 5\text{V}$ )

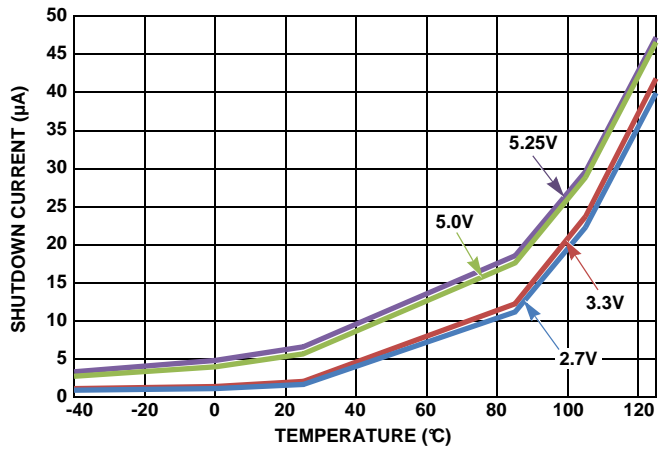

FIGURE 12. SHUTDOWN CURRENTS vs VOLTAGE AND TEMPERATURE

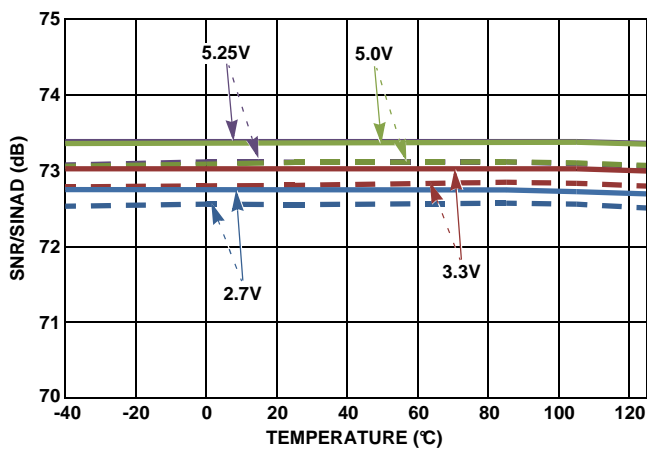

FIGURE 13. SNR AND SINAD vs SUPPLY VOLTAGE AND TEMPERATURE

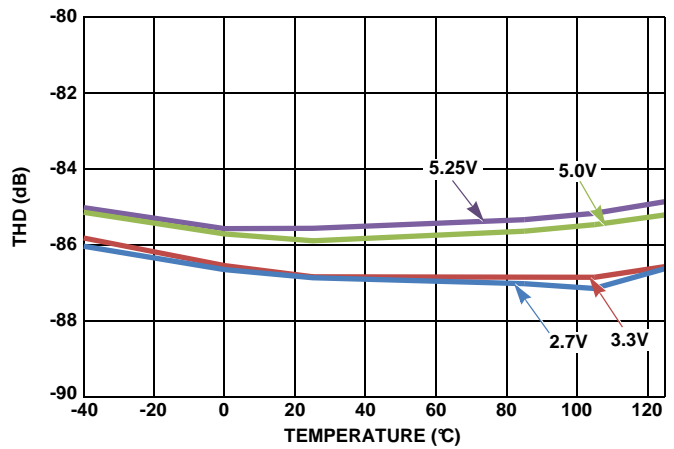

FIGURE 14. THD vs SUPPLY VOLTAGE AND TEMPERATURE

**Typical Performance Characteristics**

unless otherwise specified. (Continued)

$T_A = +25^\circ\text{C}$ ,  $V_{DD} = 5\text{V}$ ,  $V_{REF} = 5\text{V}$ ,  $f_{\text{SAMPLE}} = 125\text{kHz}$ ,  $f_{\text{SCLK}} = 20\text{MHz}$ ,

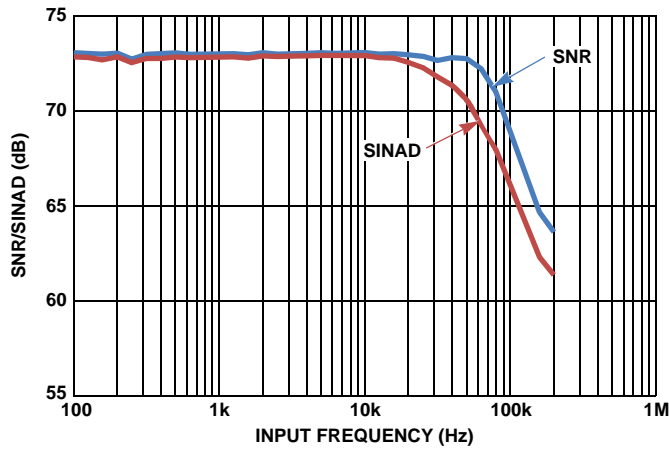

FIGURE 15. SNR AND SINAD vs INPUT FREQUENCY

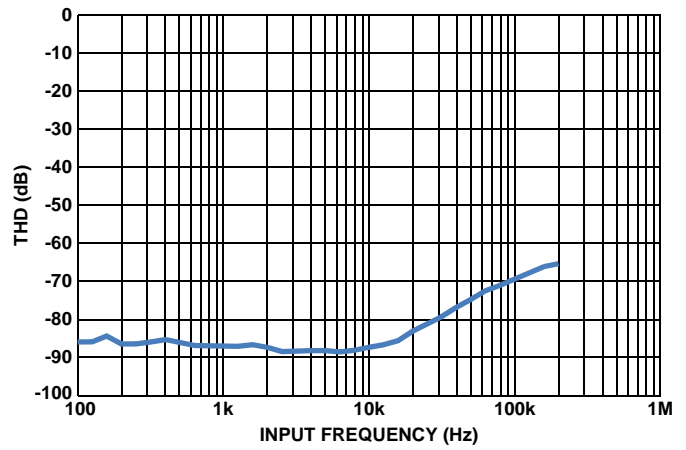

FIGURE 16. THD vs INPUT FREQUENCY

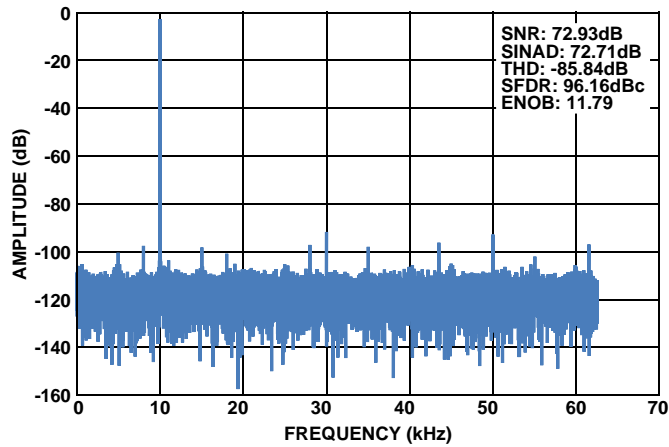

FIGURE 17. SINGLE-TONE FFT

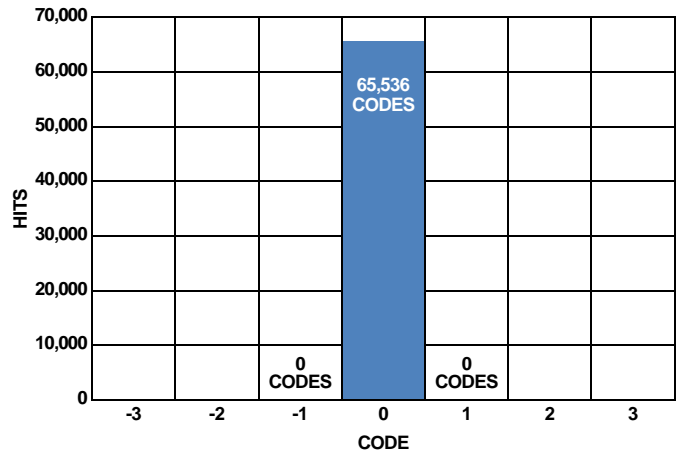

FIGURE 18. SHORTED INPUT HISTOGRAM

## Circuit Description

The ISL26310/11/12/13/14/15/19 family of 12-bit ADCs are low-power Successive Approximation-type (SAR) ADCs with 1-, 2-, 4-, or 8-channels and a choice of single-ended or differential inputs. The high-impedance buffered input simplifies interfacing to sensors and external circuitry.

The entire ISL26310/11/12/13/14/15/19 family follows the same base pinout and differs only in the analog input pins, allowing the user to replicate the basic board layout across multiple platforms with a minimum redesign effort.

The simple serial digital interface is compatible with popular FPGAs and microcontrollers and allows direct conversion control by the CNV pin.

## Functional Description

The ISL26310/11/12/13/14/15/19 devices are SAR (Successive Approximation Register) analog-to-digital converters that use capacitor-based charge redistribution as their conversion method.

These devices include an on-chip power-on reset (POR) circuit to initialize the internal digital logic when power is applied. An on-chip oscillator provides the master clock for the conversion logic. The CNV signal controls when the converter enters into its signal acquisition time (CNV = 0), and when it begins the conversion sequence after the signal has been captured (CNV = 1). The converters include a configuration register that can be accessed via the serial port. The configuration register has various bits to indicate which channel (where applicable) is selected, to activate the auto-power-down feature where the ADC is shut down between conversions, or to output the configuration register contents along with the data conversion word whenever a conversion word is read from the serial port. The serial port supports three different modes of reading the conversion data. These will be discussed later in this data sheet.

Figures 19 and 20 illustrate simplified representations of the converter analog section for differential and single-ended inputs, respectively. During the acquisition phase (CNV = 0) the input signal is presented to the  $C_s$  samples capacitors. To properly sample the signal, the CNV signal must remain low for the specified time. When CNV is taken high (CNV = 1), the switches that connect the sampling capacitors to the input are opened and the control logic begins the successive approximation sequence to convert the captured signal into a digital word. The conversion sequence timing is determined by the on-chip oscillator.

## ADC Transfer Function

The ISL26310, the ISL26312, and the ISL26314 feature differential inputs with output data coding in two's complement format (see Table 1). The size of one LSB in these devices is  $(2 \cdot V_{REF})/4096$ . Figure 21 on page 13 illustrates the ideal transfer function for these devices.

The ISL26311, ISL26313, ISL26315, and ISL26319 feature single-ended inputs with output coding in binary format (see Table 2). The size of one LSB in these devices is  $V_{REF}/4096$ . Figure 22 on page 13 illustrates the ideal transfer function for these devices.

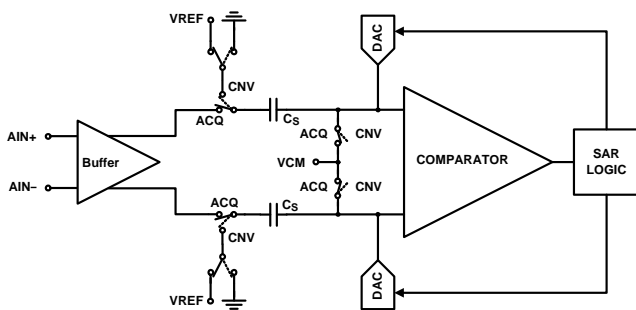

FIGURE 19. ARCHITECTURAL BLOCK DIAGRAM, DIFFERENTIAL INPUT

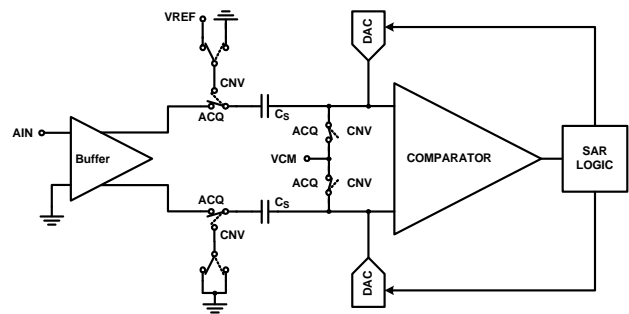

FIGURE 20. ARCHITECTURAL BLOCK DIAGRAM, SINGLE-ENDED

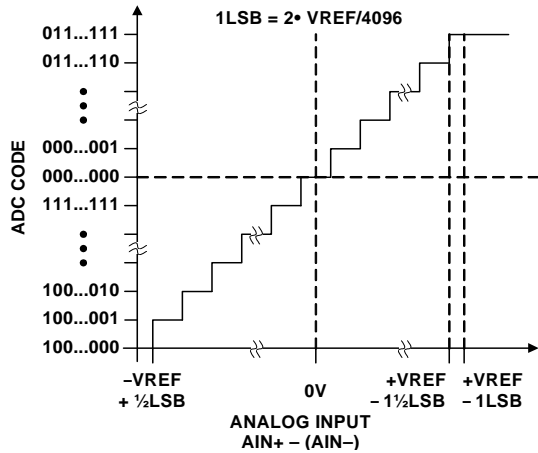

FIGURE 21. IDEAL TRANSFER CHARACTERISTICS, DIFFERENTIAL INPUT

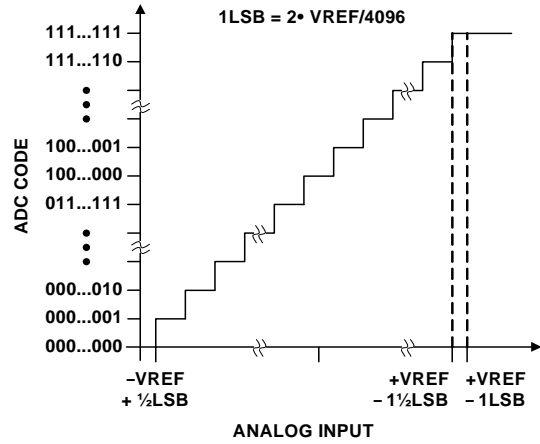

FIGURE 22. IDEAL TRANSFER CHARACTERISTICS, SINGLE-ENDED INPUT

**Analog Inputs**

Some members of the ISL26310/11/12/13/14/15/19 family feature a fully differential input with a nominal full-scale range equal to twice the applied VREF voltage. Those devices with differential inputs have a nominal full scale range equal to twice the applied VREF voltage. Each input swings VREF volts (peak-to-peak), 180° out of phase from one another for a total differential input of 2\*VREF (refer to Figures 23 and 24).

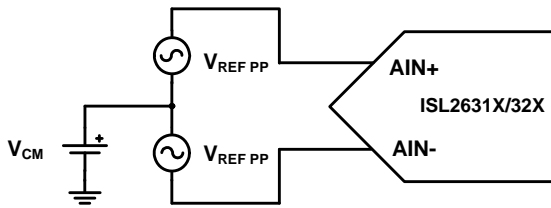

FIGURE 23. DIFFERENTIAL INPUT SIGNALING

Differential signaling offers several benefits over a single-ended input, such as:

- Doubling of the full-scale input range (and therefore the dynamic range)
- Improved even order harmonic distortion
- Better noise immunity due to common mode rejection

Figure 24 shows the relationship between the reference voltage and the full-scale differential input range for two different values of VREF. Note that the common-mode input voltage must be maintained within ±200mV of VREF/2 for differential inputs.

Those devices with single-ended inputs have a ground-referenced peak-to-peak input voltage span equal to the reference voltage.

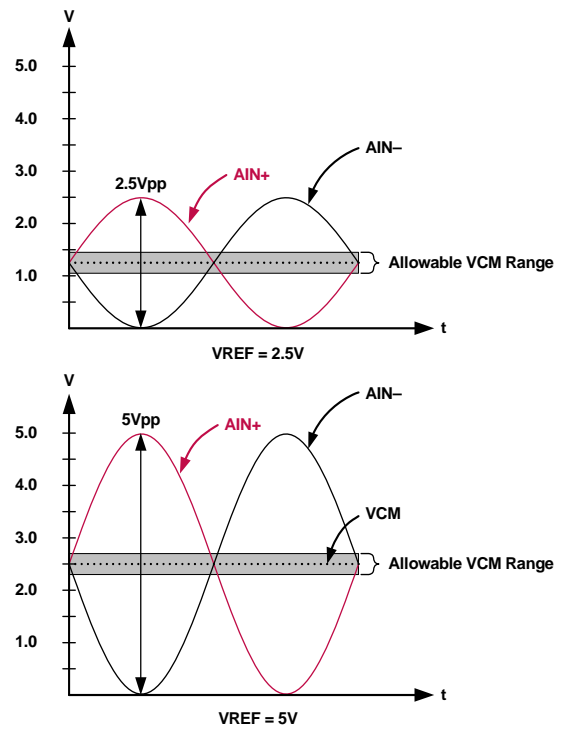

FIGURE 24. RELATIONSHIP BETWEEN VREF AND FULL-SCALE RANGE FOR DIFFERENTIAL INPUTS

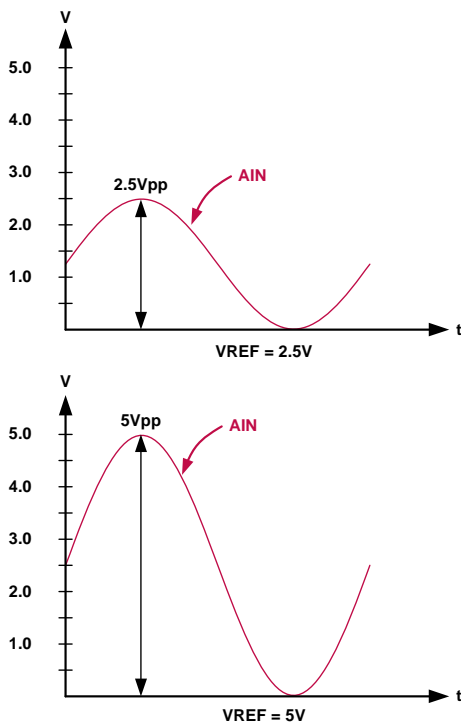

FIGURE 25. RELATIONSHIP BETWEEN VREF AND FULL-SCALE RANGE FOR SINGLE-ENDED INPUTS

### Input Multiplexer

The input of the multiplexer connects the selected analog input pins to the ADC input. A proprietary sampling circuit significantly reduces the input drive requirements, resulting in lower overall cost and board space in addition to improved performance. Note that the input capacitance is only 2-3pF during the Sampling phase, changing to 40pF during the Settling phase, resulting in an average input current of 2.5µA and an effective input capacitance of only 4pF. See Figure 26.

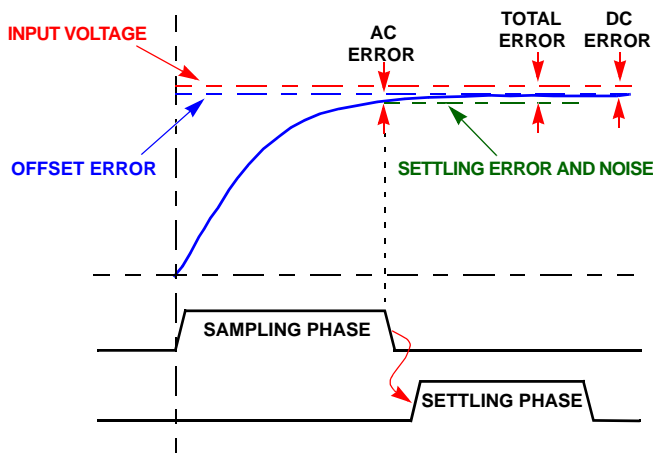

FIGURE 26. INPUT SAMPLING OPERATION

### Voltage Reference Input

An external reference voltage must be supplied to the VREF pin to set the full-scale input range of the converter. The VREF input on these devices can accept voltages ranging from 2V (nominal) to VDD, however, they are specified with VREF at a voltage of 5V with VDD at 5V. Note that exceeding VDD by more than 100mV can forward bias the ESD protection diodes and degrade measurement accuracy due to leakage current. A lower value voltage reference must be used if the device is operated with VDD at voltages lower than 5V. If the VREF pin is tied to the VDD pin, the VREF pin should be decoupled with a local 1µF ceramic capacitor as described in a later paragraph.

Figures 27 and 28 illustrate possible voltage reference options for these ADCs. Figure 27 uses the precision ISL21090 voltage reference, which exhibits exceptionally low drift and low noise. The ISL21090 must be powered from a supply greater than 4.7V.

Figure 28 illustrates the ISL21010 voltage reference used with these ADCs. The ISL21010 series voltage references have higher noise and drift than the ISL21090 devices, but operate at lower supply voltages. Therefore, these devices can readily be used when these SAR ADCs operate with VDD at voltages less than 5V.

The outputs of ISL21090 or the ISL21010 devices should be decoupled with a 1µF ceramic capacitor. A 1µF, 6.3 V, X7R, 0603 (1608 metric) MLCC type capacitor is recommended for its high frequency performance. The trace length from the VREF pin to this capacitor and the voltage reference output should be as short as possible.

The ISL26310 and ISL26313 devices (packaged in 8 pin SOIC packages) derive their voltage reference from the VDD pin. To achieve best performance, the VDD pin of these devices should be bypassed with the 1µF ceramic capacitor mentioned above.

### Power-Down/Standby Modes

In order to reduce power consumption between conversions, a number of user-selectable modes can be utilized by setting the appropriate bits in the Configuration Register.

Auto Power-down (PD0 = 0) reduces power consumption by shutting down all portions of the device except the oscillator and digital interface after completion of a conversion. There is a short recovery period after CNV is asserted Low (150µs with external reference).

In Auto Sleep mode (PD1 = 1), the device will automatically enter the low-power Sleep mode at the end of the current conversion. Recovery from this mode involves only 2.1µs and may offer an alternative to Power-down mode in some applications.

### Output Data Format

The converter output word is delivered in two's complement format in differential input mode, and straight binary in single-ended input mode of operation respectively, all MSB-first. Input exceeding the specified full-scale voltage results in a clipped output which will not return to in-range values until after the input signal has returned to the specified allowable voltage range.

Data must be read prior to the completion of the current conversion to avoid conflict and loss of data, due to overwriting of the new conversion data into the output register.

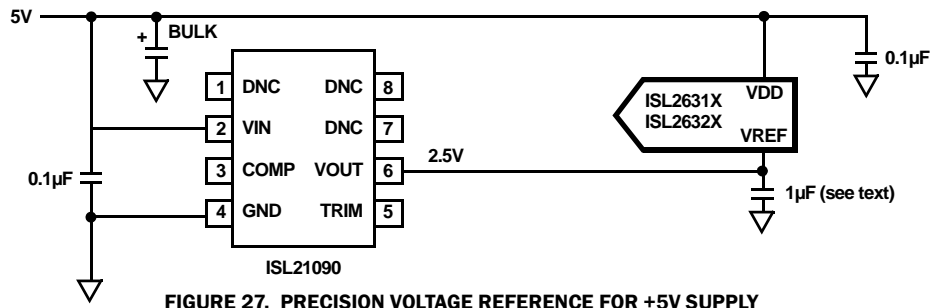

**FIGURE 27. PRECISION VOLTAGE REFERENCE FOR +5V SUPPLY**

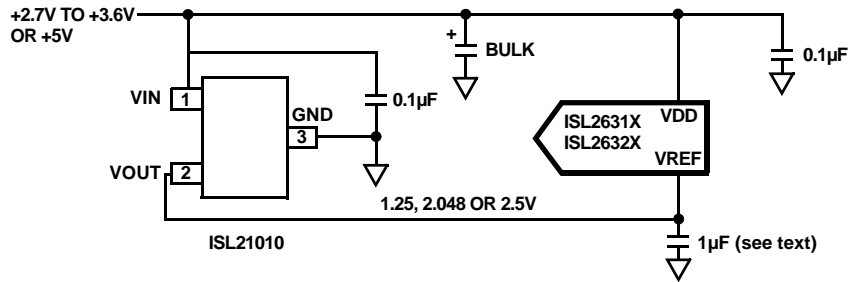

**FIGURE 28. VOLTAGE REFERENCE FOR +2.7V TO +3.6V, OR FOR +5V SUPPLY**

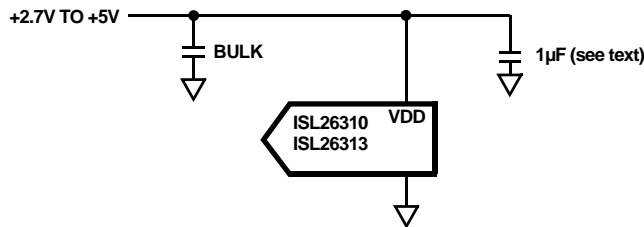

**FIGURE 29. VOLTAGE REFERENCE FOR ISL26310/313 IS DERIVED FROM VDD**

**TABLE 1. OUTPUT CODES - DIFFERENTIAL**

INPUT VOLTAGE	TWO'S COMPLEMENT (12-bit)
$>(VFS - 1.5 \text{ LSB})$	7FF
$VFS - 1.5 \text{ LSB}$	... 7FE
$-0.5 \text{ LSB}$	000 ... FFF
$-VFS + 0.5 \text{ LSB}$	801 ... 800

NOTE: VFS in the table above equals the voltage between AIN+ and AIN-. Differential full scale is equal to  $2 * VREF$ .

**TABLE 2. OUTPUT CODES - SINGLE-ENDED**

INPUT VOLTAGE	BINARY (12-bit)
$>AIN - 1.5 \text{ LSB}$	FFF
$AIN - 1.5 \text{ LSB}$	FFF ... FFE
$0.5 \text{ LSB}$	001 ... 000
$<0.5 \text{ LSB}$	000

NOTE: Single-ended full scale is equal to VREF.

## Serial Digital Interface

The ISL26310/11/12/13/14/15/19 family utilizes an SPI-compatible interface to set the device configuration and read conversion data. This flexible interface provides 3 modes of operation: Reading After Conversion (RAC), Reading During Conversion (RDC), and Reading Spanning Conversions (RSC), with an additional option providing an End of Conversion (EOC) indication on the SDO output in all 3 modes. The choice of operating mode is determined by the timing of the signals on the serial interface.

The interface consists of the data clock (SCLK), serial digital input (SDI), serial digital output (SDO), and the conversion control input (CNV). From the Idle state (after completion of a prior conversion), a High-to-Low transition on CNV indicates the beginning of input signal acquisition, with the Conversion then initiated by a subsequent Low-to-High transition. When CNV is Low, input data presented to SDI is latched on the rising edge of SCLK. Output data will be present at SDO on the falling edge of SCLK. SDO is in the high-impedance state whenever CNV is High, and activity on SCLK should be avoided during this time to avoid corruption of the conversion process. SCLK should be Low when CNV is High.

During the Nth conversion, output data indicates the conversion data and configuration settings for the N-1th conversion, while the current configuration settings apply to the N+1th conversion.

In order to minimize errors due to digital noise coupling, there should be no activity on the serial interface after the specified  $t_{DATA}$  period. Data should be read before the conversion is completed to avoid the newer results being overwritten resulting in a permanent loss of data.

### Reading After Conversion Mode Without EOC

In this mode, data transfer always occurs during the Acquisition phase, supporting the widest variety of interface data rates. Figure 30 depicts a timing waveform in this mode. From Idle, the device enters the Acquisition phase when CNV is taken Low. SDO emerges High from a high-impedance state, waiting for an SCLK to present the MSB of the current output data word. The configuration settings can be updated using SDI and at the same time previous conversion results can be read from SDO. After the communication is completed or the required acquisition time ( $t_{ACQ}$ ) has elapsed – whichever is later – CNV transitions High indicating the start of conversion. CNV must be held High continuously for a minimum of 7.2 $\mu$ s (at 125kSPS) so that the conversion is completed without enabling EOC. Subsequently CNV may be asserted Low at any time so that the next Acquisition phase can begin. This method is suitable for hosts which operate with lower frequency SCLK.

Note that when using slower SPI rates the data transfer time can exceed the minimum acquisition time, which will limit the conversion throughput to less than the maximum specified rate. For example, a 12-bit data transfer takes 12 $\mu$ s with a 1MHz SPI clock. This adds to the 7.2 $\mu$ s conversion time for an effective throughput of 52kSPS.

### Reading During Conversion Mode Without EOC

From Idle, the user initiates the input signal Acquisition mode by taking CNV Low, and then initiates a conversion after  $t_{ACQ}$  by pulsing CNV High. After the conversion starts, data is exchanged on the serial interface while CNV is held Low (as shown in Figure 31). CNV must also be asserted High before  $t_{DATA}$  to avoid enabling EOC. This method is ideal for hosts with high SCLK communication rates to operate the device at the highest conversion rates.

At the end of conversion the device enters the Idle state. After the host is certain that the conversion is completed (7.2 $\mu$ s after conversion is initiated at 125kSPS) a new acquisition can be initiated by pulling CNV Low which will initiate the Acquisition state.

### Reading Spanning Conversion Mode Without EOC

In applications desiring slower interface data rates and while still maintaining maximum possible throughput, RSC mode can be used to transfer data during both the Acquisition and Conversion phases, as shown in Figure 32.

Data exchange begins during the Acquisition phase until CNV is asserted High to initiate a conversion and SDO returns to the high-impedance state, interrupting the exchange. After CNV is returned Low, SDO will return to the state prior to the CNV pulse in order to avoid data loss. Once again data exchange occurs when CNV is Low. CNV must be asserted High before  $t_{DATA}$  in order to avoid enabling EOC.

At the end of conversion the device enters the Idle state. After the host is certain that the conversion is completed (7.2 $\mu$ s after conversion is initiated at 125kSPS) a new acquisition can be initiated by pulling CNV Low, which will take the device back to Acquisition state from Idle state.



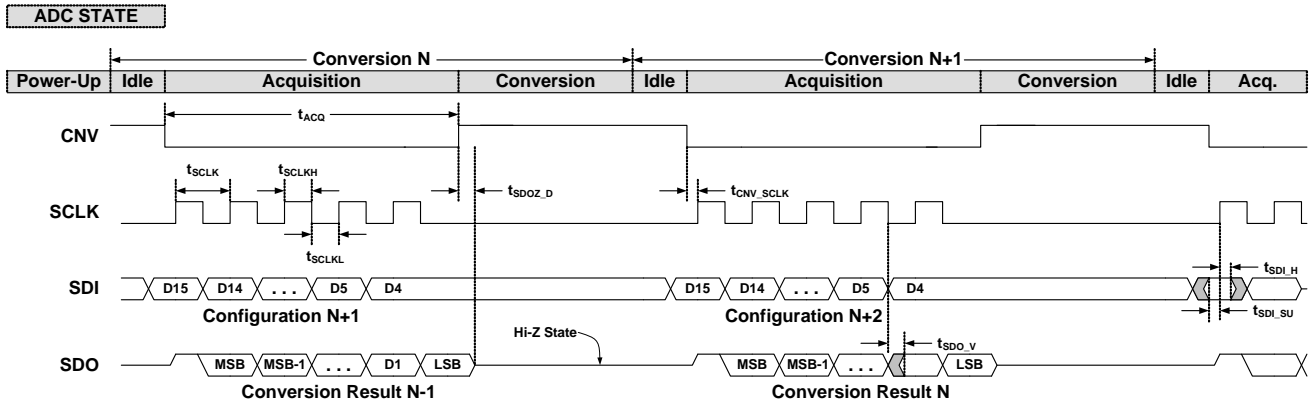

FIGURE 30. TIMING DIAGRAM FOR READING AFTER CONVERSION MODE, WITHOUT EOC

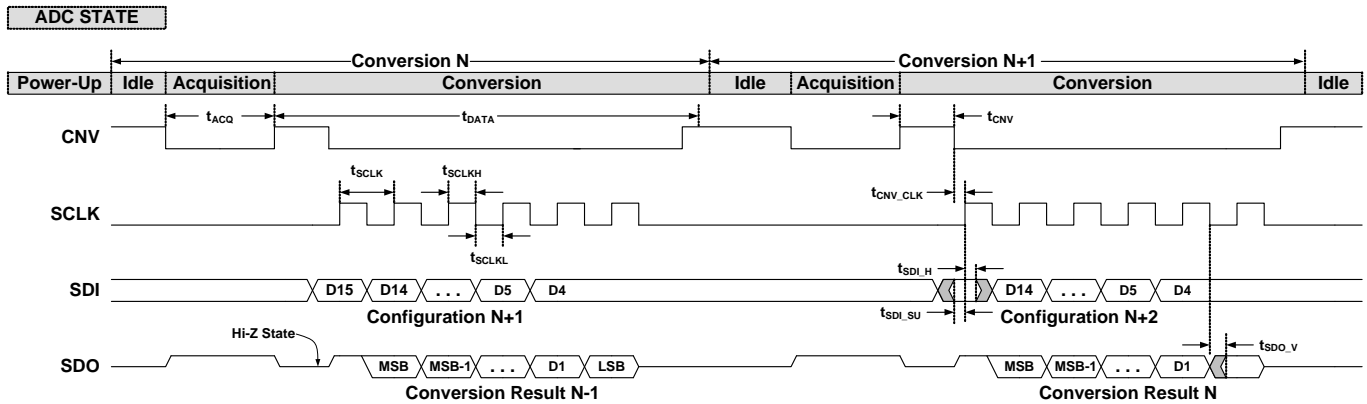
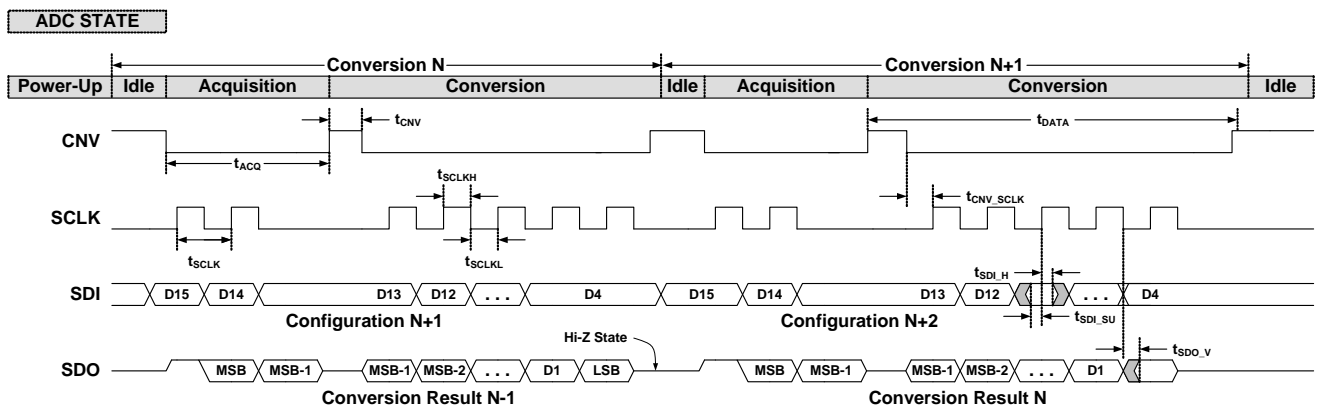

FIGURE 31. TIMING DIAGRAM FOR READING DURING CONVERSION MODE, WITHOUT EOC



Note: Transition from Acquisition to Conversion mode may occur after any integer number of clock cycles (provided that the minimum  $t_{ACQ}$  is satisfied).

FIGURE 32. TIMING DIAGRAM FOR READING SPANNING CONVERSION MODE, WITHOUT EOC

### Reading After Conversion Mode, with EOC

In this mode (Figure 33), after CNV is asserted Low to start input acquisition, a data exchange is executed by SCLK during the Acquisition period. CNV is asserted High briefly to initiate a Conversion, forcing SDO to a high-impedance state. SDO returns HIGH when CNV is asserted Low during the entire conversion period.

At the end of conversion, the device asserts SDO Low to indicate that the conversion is complete. This may be used as an interrupt to start the Acquisition phase. It should be noted (as indicated in Figure 33) that an additional pulse on CNV is required at the end of conversion to take the part back to Acquisition from Idle state.

As discussed in the “Reading After Conversion Mode Without EOC” section, the acquisition time ( $t_{ACQ}$ ) may limit the conversion throughput at slower SPI clock rates.

### Reading During Conversion Mode, with EOC

From Idle, a falling edge on CNV initiates the Acquisition mode, and then a rising edge initiates a Conversion. After the conversion is initiated, CNV is asserted Low once again. Data exchange across SDI and SDO can proceed while CNV is Low, again observing the requirements of the  $t_{DATA}$  period in order to minimize the effects of digital noise on sensitive portions of the conversion. In this mode, an additional pulse is required on SCLK after the completion of the data exchange, to transition SDO to the high-impedance state. Later, SDO is asserted low by the device indicating end of conversion. The device then returns to Idle. The falling edge of SDO may be used as an interrupt to start the Acquisition phase. See Figure 34.

### Reading Spanning Conversion Mode, with EOC

After initiating an Acquisition by bringing CNV Low, the user begins exchanging data as previously mentioned, until CNV is asserted High to initiate a conversion and SDO returns to a high-impedance state, interrupting the exchange. And, after CNV is returned Low, SDO will return to the state prior to the CNV pulse in order to avoid losing data interrupted by the conversion pulse. See Figure 35. The user should take care to observe the  $t_{DATA}$  period in order to minimize the effects of digital noise on sensitive portions of conversion. After completion of the data exchange, an additional pulse on SCLK forces SDO to a high-impedance state. At the end of conversion, the device asserts SDO Low indicating the end of conversion. The device then returns to Idle, waiting for a pulse on CNV to initiate a new Acquisition cycle.

### Accessing the Configuration Register During Data Readback

The Configuration Register contains the channel address of the current conversion data. The contents can be accessed during a normal data output sequence by continuing to clock data from SDO if the register readback mode is enabled. Both 12-bit output data words and the 16-bit configuration word are output in 28 SCLK periods, as shown in Figure 36, which demonstrates an example sequence. Note that SDO goes into the high-impedance state when CNV is High. The Configuration Register can be read during any Read Sequence by generating the additional SCLKs, with the restriction that the sequence must be completed prior to the end of the current conversion. This will prevent loss of data due to overwriting of the new conversion data into the output and configuration registers.

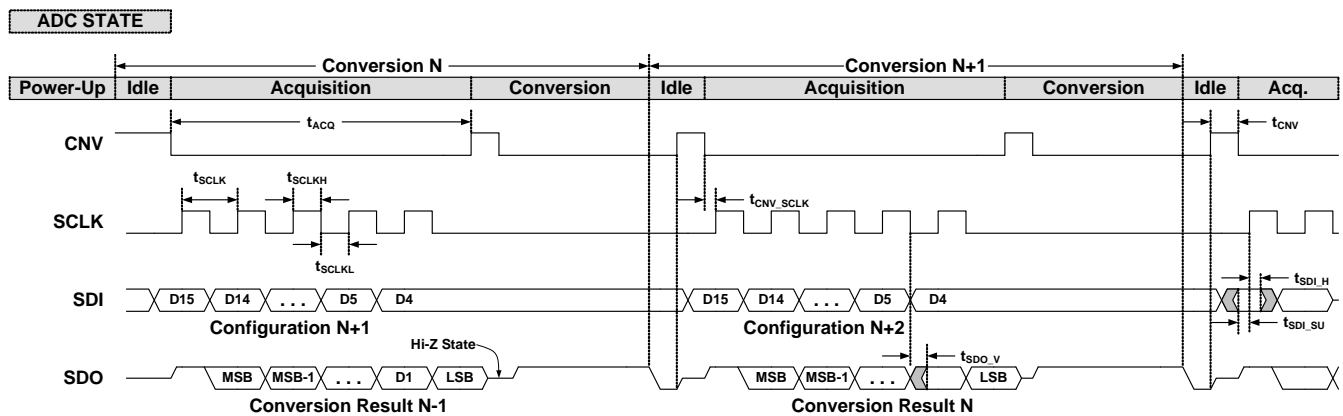

FIGURE 33. TIMING DIAGRAM FOR READING AFTER CONVERSION MODE WITH EOC ON SDO OUTPUT

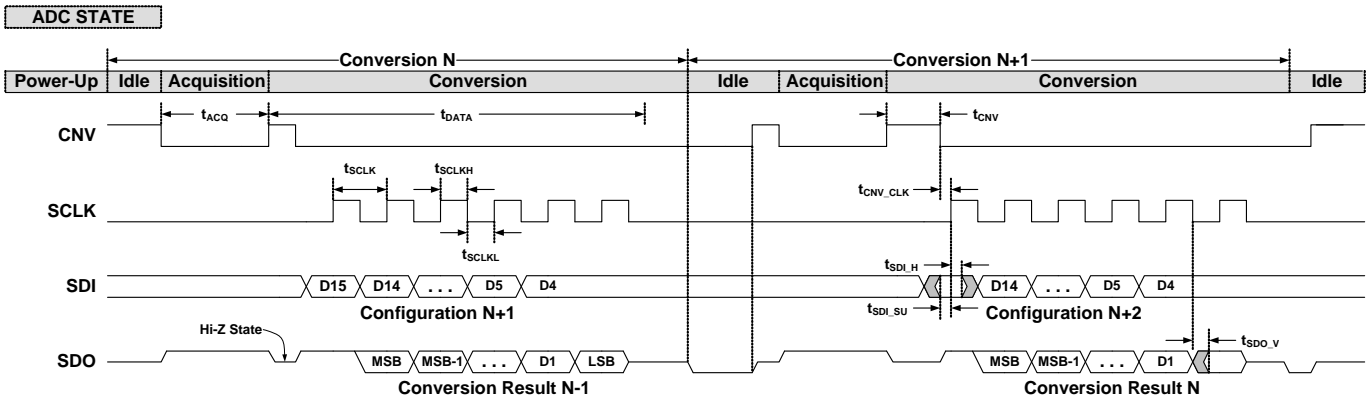
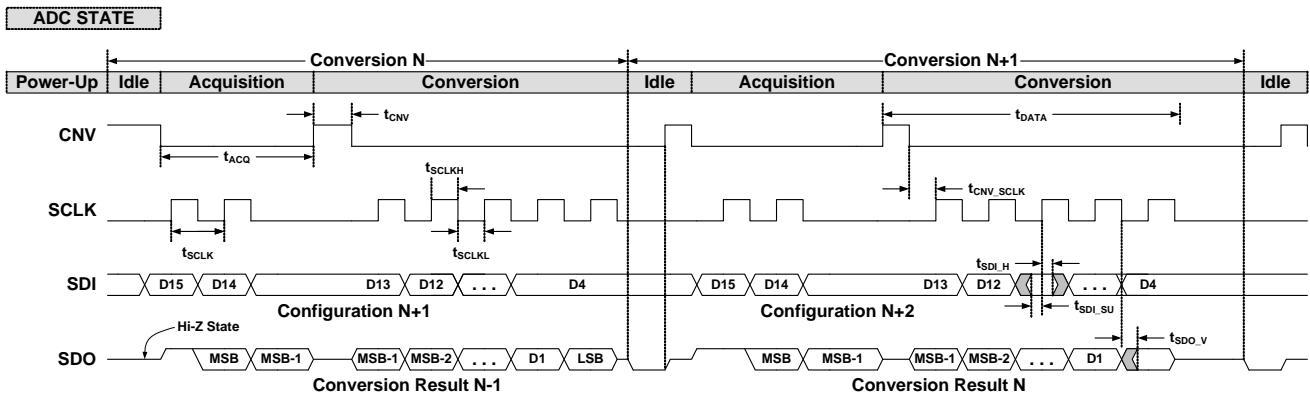

FIGURE 34. TIMING DIAGRAM FOR READING DURING CONVERSION MODE WITH EOC ON SDO OUTPUT



Note: Transition from Acquisition to Conversion mode may occur after any integer number of clock cycles (provided that the minimum  $t_{ACQ}$  is satisfied).

FIGURE 35. TIMING DIAGRAM FOR READING SPANNING CONVERSIONS MODE WITH EOC ON SDO OUTPUT

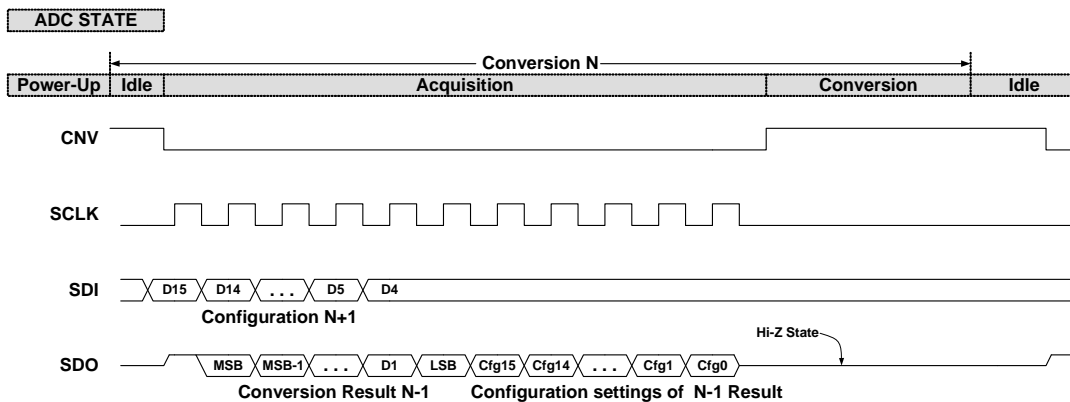

FIGURE 36. TIMING DIAGRAM FOR READING AFTER CONVERSION WITH REGISTER READBACK, WITHOUT EOC

**Device Configuration Registers**

The Input Multiplexer Channel Select and power management features are controlled by loading the appropriate bits into the 16-bit Configuration Register through the serial port, MSB-first, as shown below. The first two Load bits LD1-LD0 must be set to “11” in order to perform a Register update: any other setting will leave the Register unchanged. Changes to the Configuration Register will be implemented internally immediately following the completion of the current conversion, or require a dummy conversion in order to take effect. Also, in the case of all power management features, a recovery time will be incurred when returning to normal operation, as indicated.

**TABLE 3. CONFIGURATION REGISTER**

BIT 15 (MSB)	14	13	12	11	10	9	8
LD1	LD0	ADDR2	ADDR1	ADDR0	PM1	PM0	Unused

BIT 7	BIT 6	BIT 5	BIT 4	BIT 3	BIT 2	BIT 1	BIT 0 (LSB)
RGRD	Unused						

**TABLE 4. CONFIGURATION REGISTER 2**

BIT(S)	DESCRIPTION
15:14	Register Load word, set to “11” to update registers, otherwise previous settings are retained.
13:11	Multiplexer Channel Select word ADDR2:0. 000H: Channel AIN0 (single-ended input devices) or AIN0+/AIN0- (differential input devices) 001H: Channel AIN1 or AIN1+/AIN1- 010H: Channel AIN2 or AIN2+/AIN2- 011H: Channel AIN3 or AIN3+/AIN3- 100H: Channel AIN4 101H: Channel AIN5 110H: Channel AIN6 111H: Channel AIN7
10:9	Power Management Configuration Control 00H: Auto Power-Down mode. Device will go into Power-down mode automatically at the end of the next conversion cycle. 01H: Continuous Operation mode (default). Device remains fully powered at all times. 1xH: Auto Sleep Mode. Device will enter reduced-power Sleep mode automatically at the end of the next conversion cycle. A “1” in PM1 overrides the setting in PM0.
8	Unused
7	Register readback mode. “1” means register readback is enabled resulting in configuration settings to be output along with conversion results. “0” (default) mode of operation register settings are not output.
6:0	Unused

**Power Management Modes**

In all SPI interface modes (RAC, RDC, etc.) the device has three states of operation: Acquisition, Conversion and Idle. Power management modes decide the state of the ADC in Idle mode and are selected by the PM bits in the Configuration Register as shown in Table 3 and Table 4.

In the default mode (Continuous Operation) the ADC is fully powered in the Idle state and can be taken back to the Acquisition state instantaneously. In this mode the ADC can be operated with maximum throughput and hence is ideally suitable for applications where the ADC is operated continuously.

In Auto Sleep Mode the ISL263XX will be in a sleep state consuming less than 0.4mA. However, it should be noted that the requirements on t<sub>ACQ</sub> are more stringent in Auto Sleep mode since the device must wake up and then perform the Acquisition.

In Auto Power Down Mode (as selected by PM bits) the ADC will be in power-down condition during the Idle period, consuming less than 5µA of current. Wake-up time takes 150µs. The acquisition time (t<sub>ACQ</sub>) must be increased to account for this delay.

The power management modes provide a high degree of flexibility in trading average power consumption versus the required throughput. Significant power savings can be achieved by operating in either Auto Sleep Mode or Auto Power-Down mode depending on the throughput requirements.

## Revision History

The revision history provided is for informational purposes only and is believed to be accurate, but not warranted. Please go to web to make sure you have the latest Rev.

DATE	REVISION	CHANGE
June 22, 2012	FN7549.1	Added Part Numbers ISL26310, ISL26311, ISL26313 throughout document Added SOIC Package throughout document Updated Features List by Removing following bullets: <ul style="list-style-type: none"><li>o 125kSPS Conversion Rate</li><li>o Pin-Compatible 2/4-Channel Differential or 4/8-Channel Single-Ended Inputs</li><li>o Internal 2.5V Reference</li><li>o Available in Popular TSSOP Package</li><li>o Pb-Free (RoHS Compliant)</li></ul> Updated Functional Block Diagram on page 1 by removing voltage reference Updated Pin Compatible Family by removing ISL264XX PARTS Updated Pin Description Table to include all parts Updated conditions in Electrical Spec Table from: Electrical Specifications VREF+ = VDD(External) V, VDD = 3.3V to 5V, VCM = VDD/2, SCLK = 20MHz... To: Electrical Specifications VREF = VDD V, VDD = 2.7V to 5V, VCM = VDD/2, SCLK = 20MHz... Removed VREFIN specs from Voltage Reference Section Removed Test Level from tACQ in Auto Power Down Mode Replaced Figures 3 and 4 DNL and INL Replaced Figure 17 by changing from single line curve to frequency mode Rewrote Functional Description Section
January 11, 2012	FN7549.0	Initial Release.

## Products

Intersil Corporation is a leader in the design and manufacture of high-performance analog semiconductors. The Company's products address some of the industry's fastest growing markets, such as, flat panel displays, cell phones, handheld products, and notebooks. Intersil's product families address power management and analog signal processing functions. Go to [www.intersil.com/products](http://www.intersil.com/products) for a complete list of Intersil product families.

For a complete listing of Applications, Related Documentation and Related Parts, please see the respective device information page on intersil.com: [ISL26310](http://www.intersil.com/ISL26310), [ISL26311](http://www.intersil.com/ISL26311), [ISL26312](http://www.intersil.com/ISL26312), [ISL26313](http://www.intersil.com/ISL26313), [ISL26314](http://www.intersil.com/ISL26314), [ISL26315](http://www.intersil.com/ISL26315), [ISL26319](http://www.intersil.com/ISL26319)

To report errors or suggestions for this datasheet, please go to: [www.intersil.com/askourstaff](http://www.intersil.com/askourstaff)

FITs are available from our website at: <http://rel.intersil.com/reports/search.php>

For additional products, see [www.intersil.com/product\\_tree](http://www.intersil.com/product_tree)

Intersil products are manufactured, assembled and tested utilizing ISO9000 quality systems as noted in the quality certifications found at [www.intersil.com/design/quality](http://www.intersil.com/design/quality)

*Intersil products are sold by description only. Intersil Corporation reserves the right to make changes in circuit design, software and/or specifications at any time without notice. Accordingly, the reader is cautioned to verify that data sheets are current before placing orders. Information furnished by Intersil is believed to be accurate and reliable. However, no responsibility is assumed by Intersil or its subsidiaries for its use; nor for any infringements of patents or other rights of third parties which may result from its use. No license is granted by implication or otherwise under any patent or patent rights of Intersil or its subsidiaries.*

For information regarding Intersil Corporation and its products, see [www.intersil.com](http://www.intersil.com)

Package Outline Drawing

M16.173

16 LEAD THIN SHRINK SMALL OUTLINE PACKAGE (TSSOP)

Rev 2, 5/10

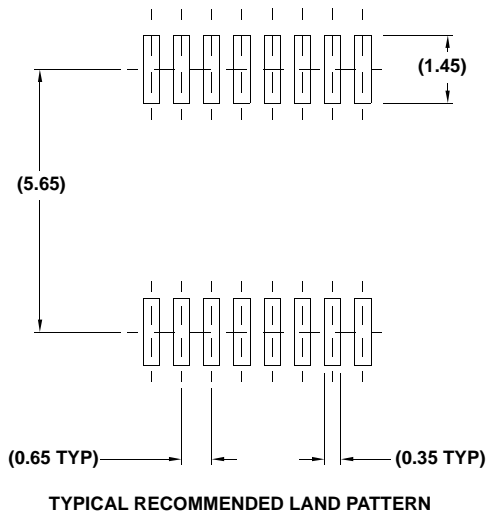
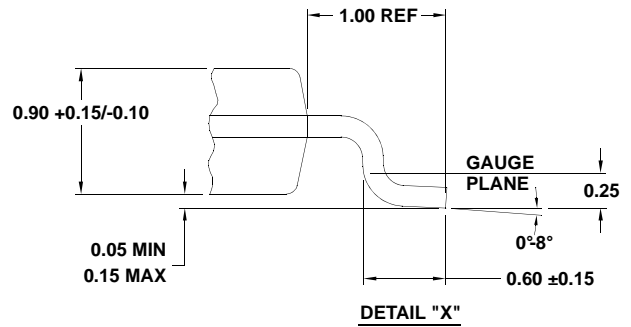
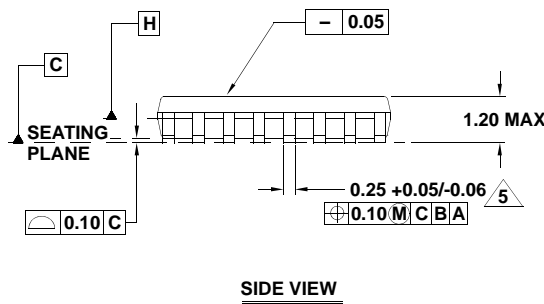
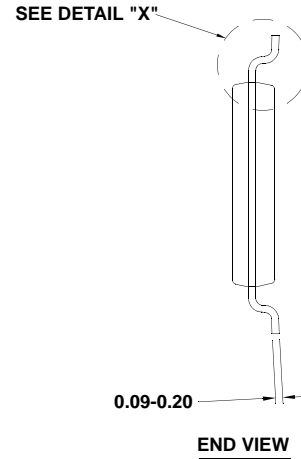
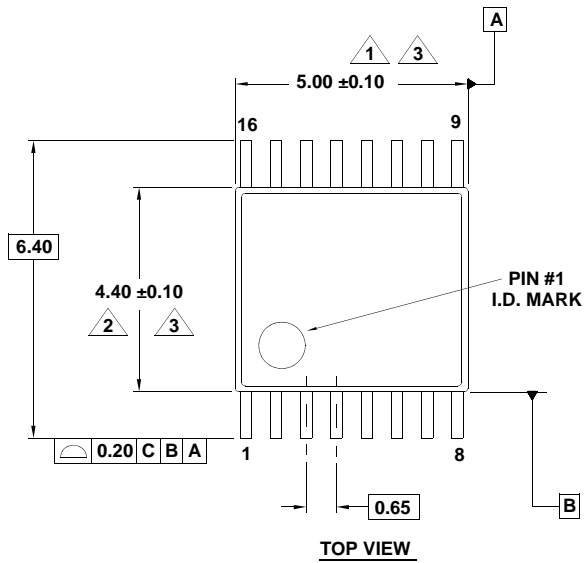

NOTES:

1. Dimension does not include mold flash, protrusions or gate burrs. Mold flash, protrusions or gate burrs shall not exceed 0.15 per side.
2. Dimension does not include interlead flash or protrusion. Interlead flash or protrusion shall not exceed 0.25 per side.
3. Dimensions are measured at datum plane H.
4. Dimensioning and tolerancing per ASME Y14.5M-1994.
5. Dimension does not include dambar protrusion. Allowable protrusion shall be 0.08mm total in excess of dimension at maximum material condition. Minimum space between protrusion and adjacent lead is 0.07mm.
6. Dimension in ( ) are for reference only.
7. Conforms to JEDEC MO-153.

# Package Outline Drawing

## M8.15

8 LEAD NARROW BODY SMALL OUTLINE PLASTIC PACKAGE

Rev 4, 1/12

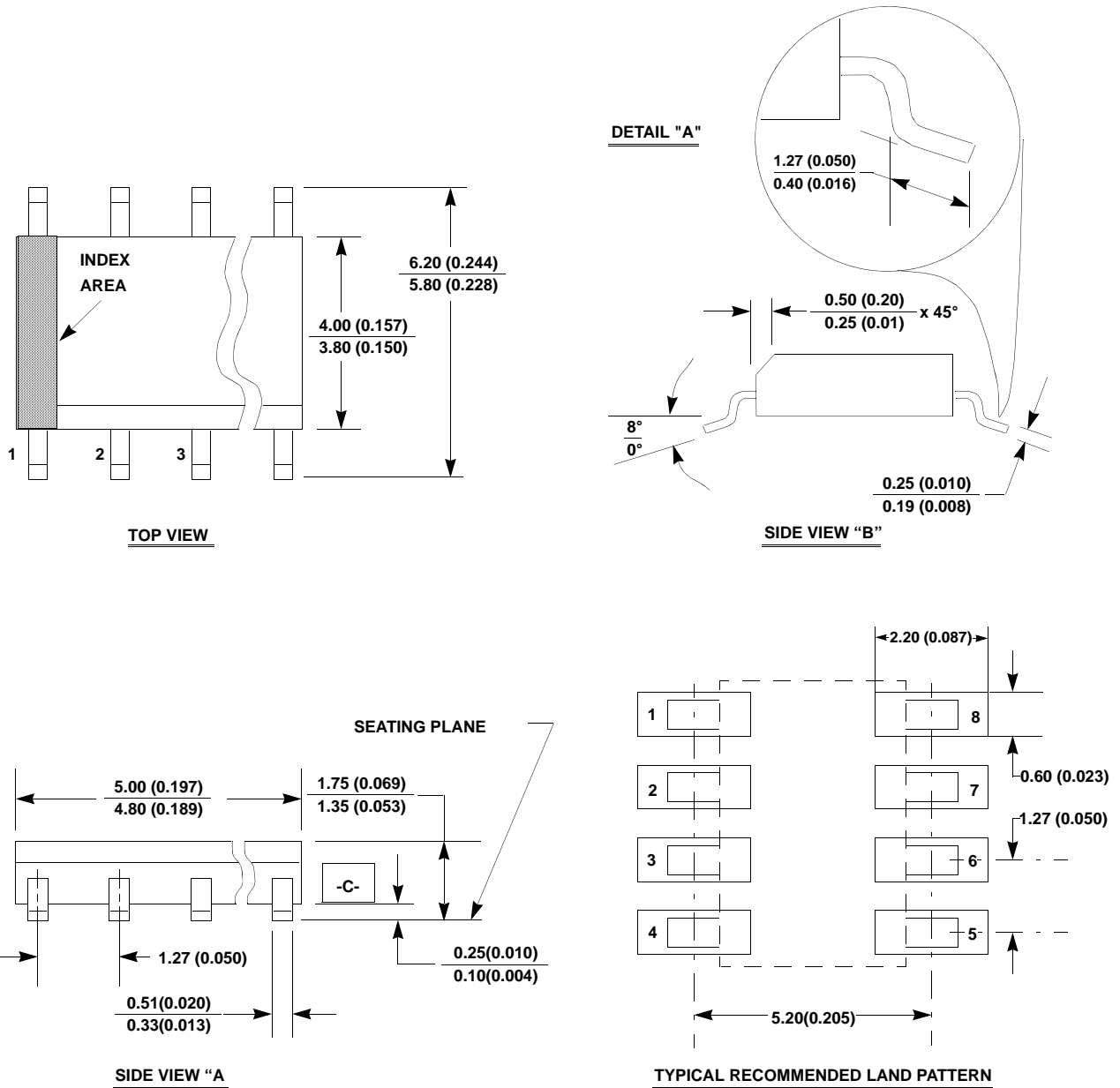

**NOTES:**

1. Dimensioning and tolerancing per ANSI Y14.5M-1994.
2. Package length does not include mold flash, protrusions or gate burrs. Mold flash, protrusion and gate burrs shall not exceed 0.15mm (0.006 inch) per side.
3. Package width does not include interlead flash or protrusions. Interlead flash and protrusions shall not exceed 0.25mm (0.010 inch) per side.
4. The chamfer on the body is optional. If it is not present, a visual index feature must be located within the crosshatched area.
5. Terminal numbers are shown for reference only.
6. The lead width as measured 0.36mm (0.014 inch) or greater above the seating plane, shall not exceed a maximum value of 0.61 mm (0.024 inch).
7. Controlling dimension: MILLIMETER. Converted inch dimensions are not necessarily exact.
8. This outline conforms to JEDEC publication MS-012-AA ISSUE C.