

High Input Voltage Charger

The ISL6294A is a cost-effective, fully integrated high input voltage single-cell Li-ion battery charger. The charger uses a CC/CV charge profile required by Li-ion batteries. The charger accepts an input voltage up to 28V but is disabled when the input voltage exceeds the OVP threshold, typically 7.3V, to prevent excessive power dissipation. The 28V rating eliminates the overvoltage protection circuit required in a low input voltage charger.

The charge current and the end-of-charge (EOC) current are programmable with external resistors. When the battery voltage is lower than typically 2.55V, the charger preconditions the battery with typically 20% of the programmed charge current. When the charge current reduces to the programmable EOC current level during the CV charge phase, an EOC indication is provided by the $\overline{\text{CHG}}$ pin, which is an open-drain output. An internal thermal foldback function protects the charger from any thermal failure.

Two indication pins ($\overline{\text{PPR}}$ and $\overline{\text{CHG}}$) allow simple interface to a microprocessor or LEDs. When no adapter is attached or when disabled, the charger draws less than 1 μ A leakage current from the battery.

Ordering Information

PART NUMBER (Note)	PART MARKING	TEMP. RANGE (°C)	PACKAGE (Pb-Free)	PKG. DWG. #
ISL6294AIRZ-T*	94A	-40 to +85	8 Ld 2x3 DFN	L8.2x3

*Please refer to TB347 for details on reel specifications.

NOTE: These Intersil Pb-free plastic packaged products employ special Pb-free material sets, molding compounds/die attach materials, and 100% matte tin plate plus anneal (e3 termination finish, which is RoHS compliant and compatible with both SnPb and Pb-free soldering operations). Intersil Pb-free products are MSL classified at Pb-free peak reflow temperatures that meet or exceed the Pb-free requirements of IPC/JEDEC J STD-020.

Features

- Complete Charger for Single-Cell Li-ion/Polymer Batteries
- Integrated Pass Element and Current Sensor
- No External Blocking Diode Required
- Low Component Count and Cost
- 1% Voltage Accuracy
- Programmable Charge Current
- **Programmable End-of-Charge Current**
- **Charge Current Thermal Foldback for Thermal Protection**
- Trickle Charge for Fully Discharged Batteries
- **28V Maximum Voltage for the Power Input**
- Power Presence and Charge Indications
- Less Than 1 μ A Leakage Current off the Battery When No Input Power Attached or Charger Disabled
- Ambient Temperature Range: -40°C to +85°C
- **8 Ld 2x3 DFN Package**
- Pb-Free (RoHS Compliant)

Applications

- Mobile Phones
- Blue-Tooth Devices
- PDAs
- MP3 Players
- Stand-Alone Chargers
- Other Handheld Devices

Pinout

ISL6294A
(8 LD DFN)
TOP VIEW

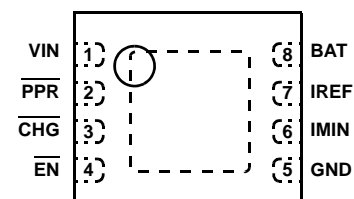

ISL6294A

Absolute Maximum Ratings (Reference to GND)

VIN	-0.3V to 30V
IMIN, IREF, BAT, CHG, EN, PPR	-0.3V to 7V

Recommended Operating Conditions

Ambient Temperature Range	-40°C to 85°C
Maximum Supply Voltage (VIN Pin)	28V
Operating Supply Voltage (VIN Pin)	4.5V to 6.5V
Programmed Charge Current	100mA to 900mA

Thermal Information

Thermal Resistance	θ_{JA} (°C/W)	θ_{JC} (°C/W)
DFN Package (Notes 1, 2)	59	4.5
Maximum Junction Temperature (Plastic Package)	+150°C	
Maximum Storage Temperature Range	-65°C to +150°C	
Pb-Free Reflow Profile	see link below	
	http://www.intersil.com/pbfree/Pb-FreeReflow.asp	

CAUTION: Do not operate at or near the maximum ratings listed for extended periods of time. Exposure to such conditions may adversely impact product reliability and result in failures not covered by warranty.

NOTES:

- θ_{JA} is measured in free air with the component mounted on a high effective thermal conductivity test board with "direct attach" features. See Tech Brief TB379.
- For θ_{JC} , the "case temp" location is the center of the exposed metal pad on the package underside.

Electrical Specifications Typical Values Are Tested at $V_{IN} = 5V$ and the T_A at +25°C.

PARAMETER	SYMBOL	TEST CONDITIONS	MIN	TYP	MAX	UNITS
POWER-ON RESET						
Rising POR Threshold	V_{POR}	$V_{BAT} = 3.0V$, use \overline{PPR} to indicate the comparator output.	3.3	3.9	4.3	V
Falling POR Threshold	V_{POR}		2.7	3.4	3.6	V
VIN-BAT OFFSET VOLTAGE						
Rising Edge	V_{OS}	$V_{BAT} = 4.0V$, use CHG pin to indicate the comparator output (Note 3)	-	90	150	mV
Falling Edge	V_{OS}		10	50	-	mV
OVERVOLTAGE PROTECTION						
Overvoltage Protection Threshold	V_{OVP}	(Note 4) Use \overline{PPR} to indicate the comparator output	6.9	7.3	7.7	V
OVP Threshold Hysteresis			100	240	400	mV
STANDBY CURRENT						
BAT Pin Sink Current	$I_{STANDBY}$	Charger disabled or the input is floating $V_{BAT} = 4.2V$	-	-	1.0	μA
VIN Pin Supply Current	I_{VIN}	Charger disabled	-	350	600	μA
VIN Pin Supply Current	I_{VIN}	Charger enabled	-	500	800	μA
VOLTAGE REGULATION						
Output Voltage	V_{CH}	Charge current = 20mA	4.158	4.20	4.242	V
PMOS ON-Resistance	$r_{DS(ON)}$	$V_{IN} = 4.1V$, charge current = 0.3A	-	0.6	-	Ω
CHARGE CURRENT (Note 5)						
IREF Pin Output Voltage	I_{IREF}	$V_{BAT} = 3.8V$	1.18	1.22	1.26	V
Constant Charge Current	I_{CHG}	$V_{IN} = 5V$, $R_{IREF} = 24.3k\Omega$, $V_{BAT} = 2.8V$ to 4.0V	450	500	550	mA
Trickle Charge Current	I_{TRK}	$V_{IN} = 5V$, $R_{IREF} = 24.3k\Omega$, $V_{BAT} = 2.4V$	70	95	130	mA
End-of-Charge Current	I_{MIN}	$V_{IN} = 5V$, $R_{IMIN} = 243k\Omega$	33	45	57	mA
EOC Rising Threshold		$V_{IN} = 5V$, $R_{IMIN} = 243k\Omega$	325	380	415	mA
PRECONDITIONING CHARGE THRESHOLD						
Preconditioning Charge Threshold Voltage	V_{MIN}		2.45	2.55	2.65	V
Preconditioning Voltage Hysteresis	V_{MINHYS}		-	250	-	mV
INTERNAL TEMPERATURE MONITORING						
Charge Current Foldback Threshold (Note 6)	T_{FOLD}		100	115	130	°C

Electrical Specifications Typical Values Are Tested at $V_{IN} = 5V$ and the T_A at $+25^{\circ}C$. (Continued)

PARAMETER	SYMBOL	TEST CONDITIONS	MIN	TYP	MAX	UNITS
LOGIC INPUT AND OUTPUTS						
\overline{EN} Pin Logic Input High			1.3	-	-	V
\overline{EN} Pin Logic Input Low			-	-	0.5	V
\overline{EN} Pin Internal Pull-Down Resistance			100	200	400	k Ω
\overline{CHG} Sink Current when LOW		Pin Voltage = 1V	10	20	-	mA
\overline{CHG} Leakage Current when HIGH		$V_{CHG} = 6.5V$	-	-	1	μA
\overline{PPR} Sink Current when LOW		Pin Voltage = 1V	10	20	-	mA
\overline{PPR} Leakage Current when HIGH		$V_{PPR} = 6.5V$	-	-	1	μA

NOTES:

- The 4.0V V_{BAT} is selected so that the \overline{CHG} output can be used as the indication for the offset comparator output indication. If the V_{BAT} is lower than the POR threshold, no output pin can be used for indication.
- For junction temperature below $+100^{\circ}C$.
- The charge current can be affected by the thermal foldback function if the IC under the test setup cannot dissipate the heat.
- Limits should be considered typical and are not production tested.

Pin Descriptions

VIN - Power input. The absolute maximum input voltage is 28V. A 0.47 μF or larger value X5R ceramic capacitor is recommended to be placed very close to the input pin for decoupling purpose. Additional capacitance may be required to provide a stable input voltage.

PPR - Open-drain power presence indication. The open-drain MOSFET turns on when the input voltage is above the POR threshold but below the OVP threshold and off otherwise. This pin is capable to sink 10mA (minimum) current to drive an LED. The maximum voltage rating for this pin is 7V. This pin is independent of the \overline{EN} pin input.

CHG - Open-drain charge indication pin. This pin outputs a logic LOW when a charge cycle starts and turns to HIGH when the end-of-charge (EOC) condition is qualified. This pin is capable to sink 10mA minimum current to drive an LED. When the charger is disabled, the \overline{CHG} outputs high impedance.

EN - Enable input. This is a logic input pin to disable or enable the charger. Drive to HIGH to disable the charger. When this pin is driven to LOW or left floating, the charger is enabled. This pin has an internal 200k Ω pull-down resistor.

GND - System ground.

IMIN - End-of-charge (EOC) current program pin. Connect a resistor between this pin and the GND pin to set the EOC current. The EOC current I_{MIN} can be programmed by Equation 1:

$$I_{MIN} = \frac{11000}{R_{IMIN}} \quad (\text{mA}) \quad (\text{EQ. 1})$$

Where R_{IMIN} is in k Ω . The programmable range covers 5% (or 10mA, whichever is higher) to 50% of I_{REF} . When

programmed to less than 5% or 10mA, the stability is not guaranteed.

IREF - Charge-current program and monitoring pin. Connect a resistor between this pin and the GND pin to set the charge current limit determined by Equation 2:

$$I_{REF} = \frac{12089}{R_{IREF}} \quad (\text{mA}) \quad (\text{EQ. 2})$$

Where R_{IREF} is in k Ω . The I_{REF} pin voltage also monitors the actual charge current during the entire charge cycle, including the trickle, constant-current, and constant-voltage phases. When disabled, $V_{IREF} = 0V$.

BAT - Charger output pin. Connect this pin to the battery. A 1 μF or larger X5R ceramic capacitor is recommended for decoupling and stability purposes. When the \overline{EN} pin is pulled to logic HIGH, the BAT output is disabled.

EPAD - Exposed pad. Connect as much as possible copper to this pad either on the component layer or other layers through thermal vias to enhance the thermal performance.

Typical Applications

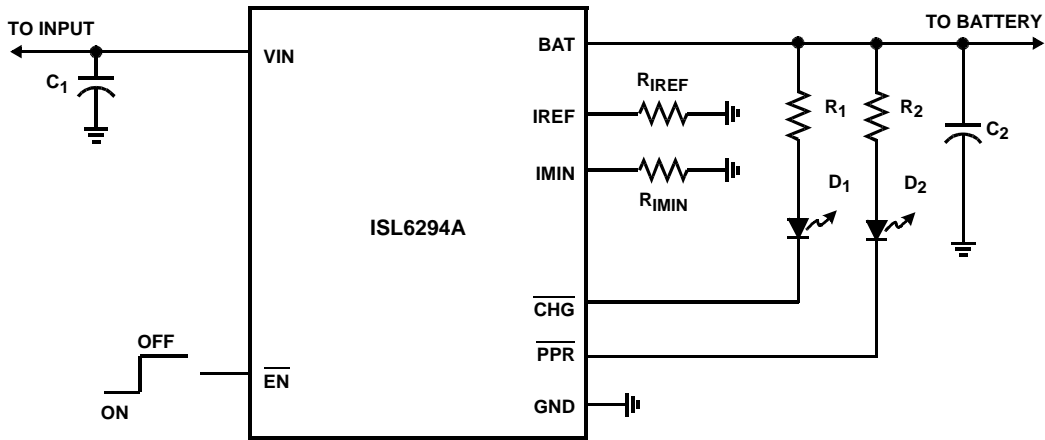

FIGURE 1. TYPICAL APPLICATION CIRCUIT INTERFACING TO INDICATION LEDs

TABLE 1. COMPONENT DESCRIPTION FOR FIGURE 1

PART	DESCRIPTION
C ₁	1µF X5R ceramic capacitor
C ₂	1µF X5R ceramic capacitor
R _{IREF}	24.3kΩ, 1%, for 500mA charge current
R _{IMIN}	243kΩ, 1%, for 45mA EOC current
R ₁ , R ₂	300Ω, 5%
D ₁ , D ₂	LEDs for indication

TABLE 2. COMPONENT DESCRIPTION FOR FIGURE 2

PART	DESCRIPTION
C ₁	1µF X5R ceramic capacitor
C ₂	1µF X5R ceramic capacitor
R _{IREF}	24.3kΩ, 1%, for 500mA charge current
R _{IMIN}	243kΩ, 1%, for 45mA EOC current
R ₁ , R ₂	100kΩ, 5%

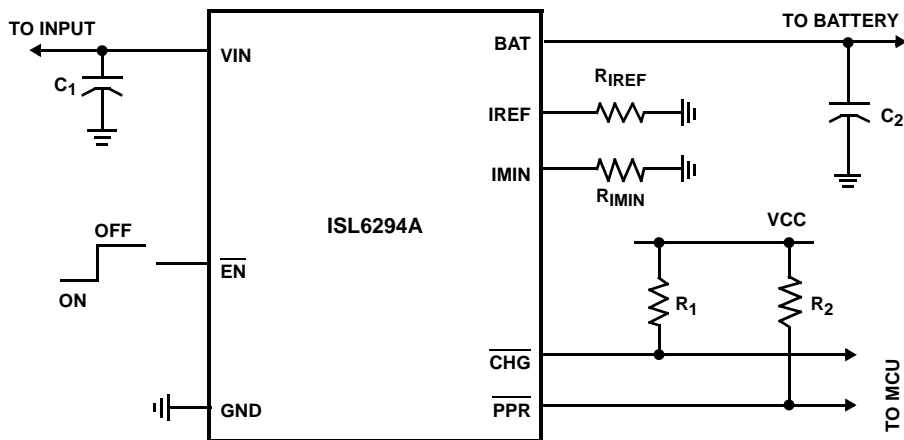

FIGURE 2. TYPICAL APPLICATION CIRCUIT WITH THE INDICATION SIGNALS INTERFACING TO A MCU

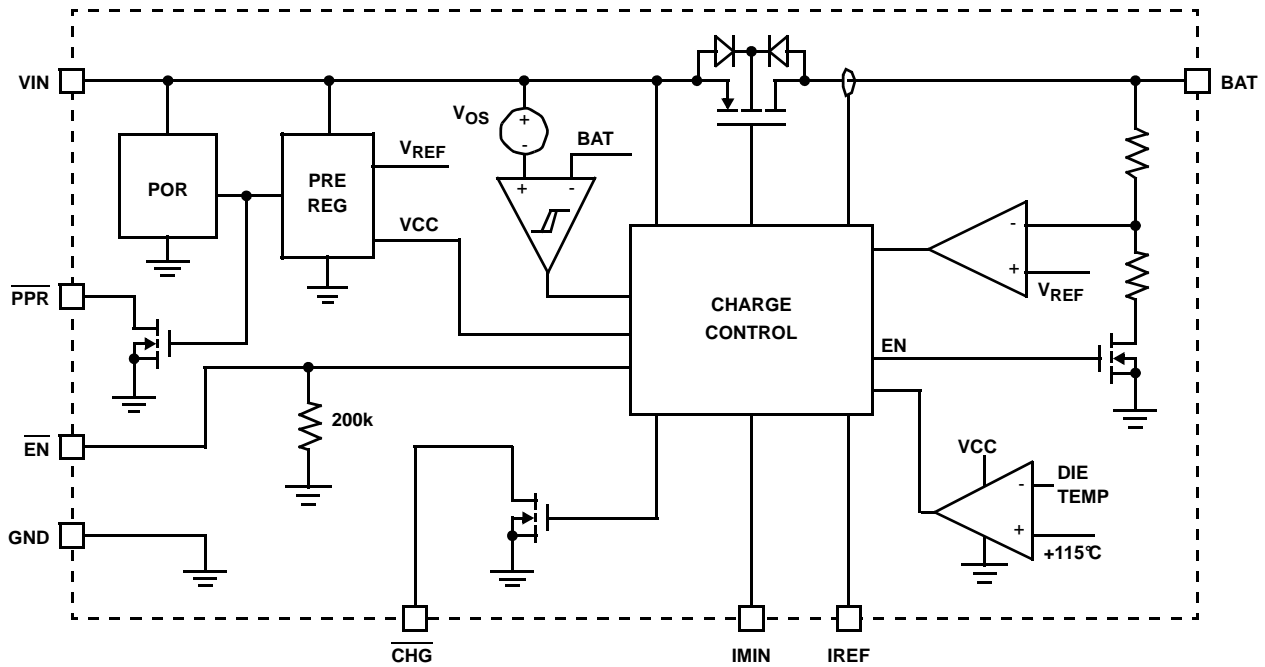

FIGURE 3. BLOCK DIAGRAM

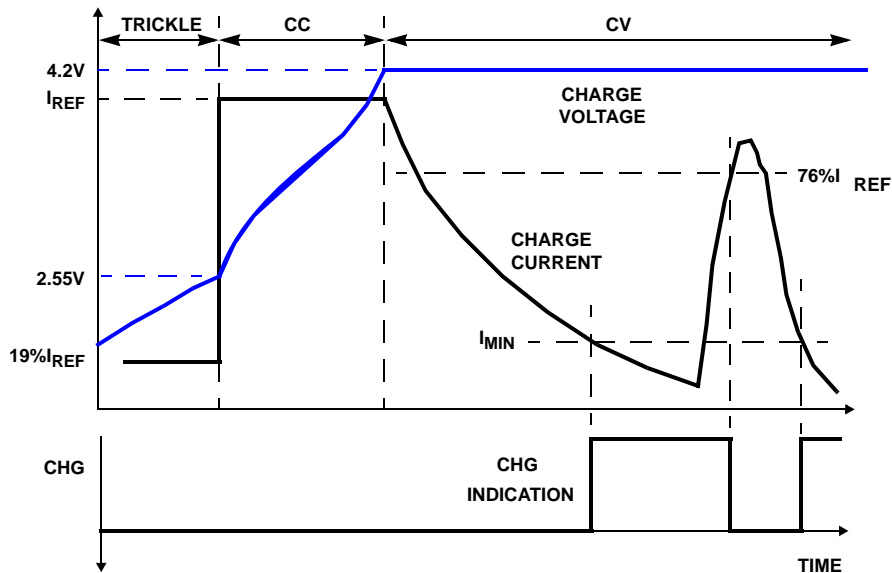

FIGURE 4. TYPICAL CHARGE PROFILE

Description

The ISL6294A charges a Li-ion battery using a CC/CV profile. The constant current I_{REF} is set with the external resistor R_{IREF} (see Figure 1) and the constant voltage is fixed at 4.2V. If the battery voltage is below a typical 2.55V trickle-charge threshold, the ISL6294A charges the battery with a trickle current of 19% of I_{REF} until the battery voltage rises above the trickle charge threshold. Fast charge CC mode is maintained at the rate determined by programming I_{REF} until the cell voltage rises to 4.2V. When the battery

voltage reaches 4.2V, the charger enters a CV mode and regulates the battery voltage at 4.2V to fully charge the battery without the risk of over charge. Upon reaching an end-of-charge (EOC) current, the charger indicates the charge completion with the \overline{CHG} pin, but the charger continues to output the 4.2V voltage. Figure 4 shows the typical charge waveforms after the power is on.

The EOC current level I_{MIN} is programmable with the external resistor R_{IMIN} (see Figure 1). The CHG signal turns

to LOW when the trickle charge starts and rises to HIGH at the EOC. After the EOC is reached, the charge current has to rise to typically 76% I_{REF} for the \overline{CHG} signal to turn on again, as shown in Figure 4. The current surge after EOC can be caused by a load connected to the battery.

A thermal foldback function reduces the charge current anytime when the die temperature reaches typically +115°C. This function guarantees safe operation when the printed-circuit board (PCB) is not capable of dissipating the heat generated by the linear charger. The ISL6294A accepts an input voltage up to 28V but disables charging when the input voltage exceeds the OVP threshold, typically 7.3V, to protect against unqualified or faulty AC adapters.

\overline{PPR} Indication

The \overline{PPR} pin is an open-drain output to indicate the presence of the AC adapter. Whenever the input voltage is higher than the POR threshold, the \overline{PPR} pin turns on the internal open-drain MOSFET to indicate a logic LOW signal, independent on the \overline{EN} -pin input. When the internal open-drain FET is turned off, the \overline{PPR} pin should leak less than 1 μ A current. When turned on, the \overline{PPR} pin should be able to sink at least 10mA current under all operating conditions.

The \overline{PPR} pin can be used to drive an LED (see Figure 1) or to interface with a microprocessor.

Power-Good Range

The power-good range is defined by the following three conditions:

1. $V_{IN} > V_{POR}$
2. $V_{IN} - V_{BAT} > V_{OS}$
3. $V_{IN} < V_{OVP}$

where the V_{OS} is the offset voltage for the input and output voltage comparator, discussed shortly, and the V_{OVP} is the overvoltage protection threshold given in the "Electrical Specifications" table on page 2. All V_{POR} , V_{OS} , and V_{OVP} have hysteresis, as given in the "Electrical Specifications" table on page 2. The charger will not charge the battery if the input voltage is not in the power-good range.

Input and Output Comparator

The charger will not be enabled unless the input voltage is higher than the battery voltage by an offset voltage V_{OS} . The purpose of this comparator is to ensure that the charger is turned off when the input power is removed from the charger. Without this comparator, it is possible that the charger will fail to power-down when the input is removed and the current can leak through the PFET pass element to continue biasing the POR and the Pre-Regulator blocks, as shown in Figure 3.

\overline{CHG} Indication

The \overline{CHG} is an open-drain output capable to at least 10mA current when the charger starts to charge and turns off when the EOC current is reached. The \overline{CHG} signal is interfaced either with a microprocessor GPIO or an LED for indication.

\overline{EN} Input

\overline{EN} is an active-low logic input to enable the charger. Drive the \overline{EN} pin to LOW or leave it floating to enable the charger. This pin has a 200k Ω internal pull-down resistor so when left floating, the input is equivalent to logic LOW. Drive this pin to HIGH to disable the charger. The threshold for HIGH is given in the "Electrical Specifications" table on page 2.

I_{REF} Pin

The I_{REF} pin has the two functions as described in the "Pin Descriptions" on page 3. When setting the fast charge current, the charge current is guaranteed to have 10% accuracy with the charge current set at 500mA. When monitoring the charge current, the accuracy of the I_{REF} pin voltage vs the actual charge current has the same accuracy as the gain from the I_{REF} pin current to the actual charge current. The accuracy is 10% at 500mA and is expected to drop to 30% of the actual current (not the set constant charge current) when the current drops to 50mA.

Operation Without the Battery

The ISL6294A relies on a battery for stability and is not guaranteed to be stable if the battery is not connected. With a battery, the charger will be stable with an output ceramic decoupling capacitor in the range of 1 μ F to 200 μ F. The maximum load current is limited by the dropout voltage or the thermal foldback.

Dropout Voltage

The constant current may not be maintained due to the $r_{DS(ON)}$ limit at a low input voltage. The worst case ON-resistance of the pass FET is 1.2 Ω the maximum operating temperature, thus if tested with 0.5A current and 3.8V battery voltage, constant current could not be maintained when the input voltage is below 4.4V.

Thermal Foldback

The thermal foldback function starts to reduce the charge current when the internal temperature reaches a typical value of +115°C.

Applications Information

Input Capacitor Selection

The input capacitor is required to suppress the power supply transient response during transitions. Mainly this capacitor is selected to avoid oscillation during the start-up when the input supply is passing the POR threshold and the V_{IN} - V_{BAT} comparator offset voltage. When the battery voltage is above the POR threshold, the V_{IN} - V_{BAT} offset voltage dominates

the hysteresis value. Typically, a 1 μ F X5R ceramic capacitor should be sufficient to suppress the power supply noise.

Output Capacitor Selection

The criteria for selecting the output capacitor is to maintain the stability of the charger as well as to bypass any transient load current. The minimum capacitance is a 1 μ F X5R ceramic capacitor. The actual capacitance connected to the output is dependent on the actual application requirement.

Charge Current Limit

The actual charge current in the CC mode is limited by several factors in addition to the set I_{REF} . Figure 5 shows three limits for the charge current in the CC mode. The charge current is limited by the ON-resistance of the pass element (power P-Channel MOSFET) if the input and the output voltage are too close to each other. The solid curve shows a typical case when the battery voltage is 4.0V and the charge current is set to 700mA. The non-linearity on the r_{ON} -limited region is due to the increased resistance at higher die temperature. If the battery voltage increases to higher than 4.0V, the entire curve moves towards the right side. As the input voltage increases, the charge current may be reduced due to the thermal foldback function. The limit caused by the thermal limit is dependent on the thermal impedance. As the thermal impedance increases, the thermal-limited curve moves towards the left, as shown in Figure 5.

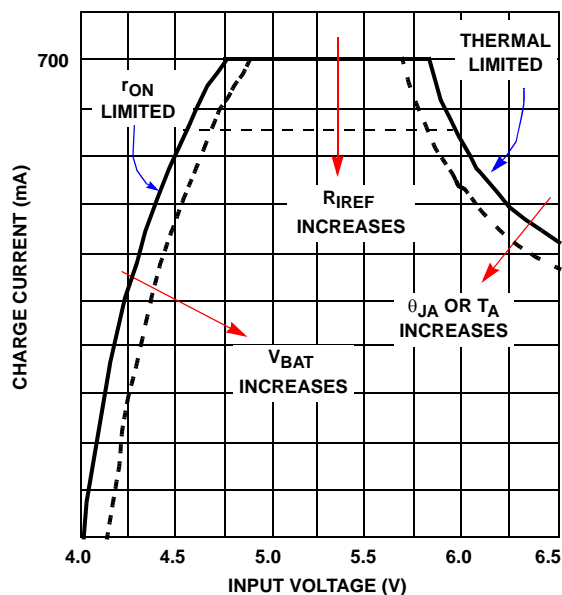

FIGURE 5. CHARGE CURRENT LIMITS IN THE CC MODE

Layout Guidance

The ISL6294A uses a thermally-enhanced DFN package that has an exposed thermal pad at the bottom side of the package. The layout should connect as much as possible to copper on the exposed pad. Typically the component layer is more effective in dissipating heat. The thermal impedance can be further reduced by using other layers of copper connecting to the exposed pad through a thermal via array. Each thermal via is recommended to have 0.3mm diameter and 1mm distance from other thermal vias.

Input Power Sources

The input power source is typically a well-regulated wall cube with 1-meter length wire or a USB port. The input voltage ranges from 4.25V to 6.5V under full-load and unloaded conditions. The ISL6294A can withstand up to 28V on the input without damaging the IC. If the input voltage is higher than typically 7.3V, the charger stops charging.

Dual Flat No-Lead Plastic Package (DFN)

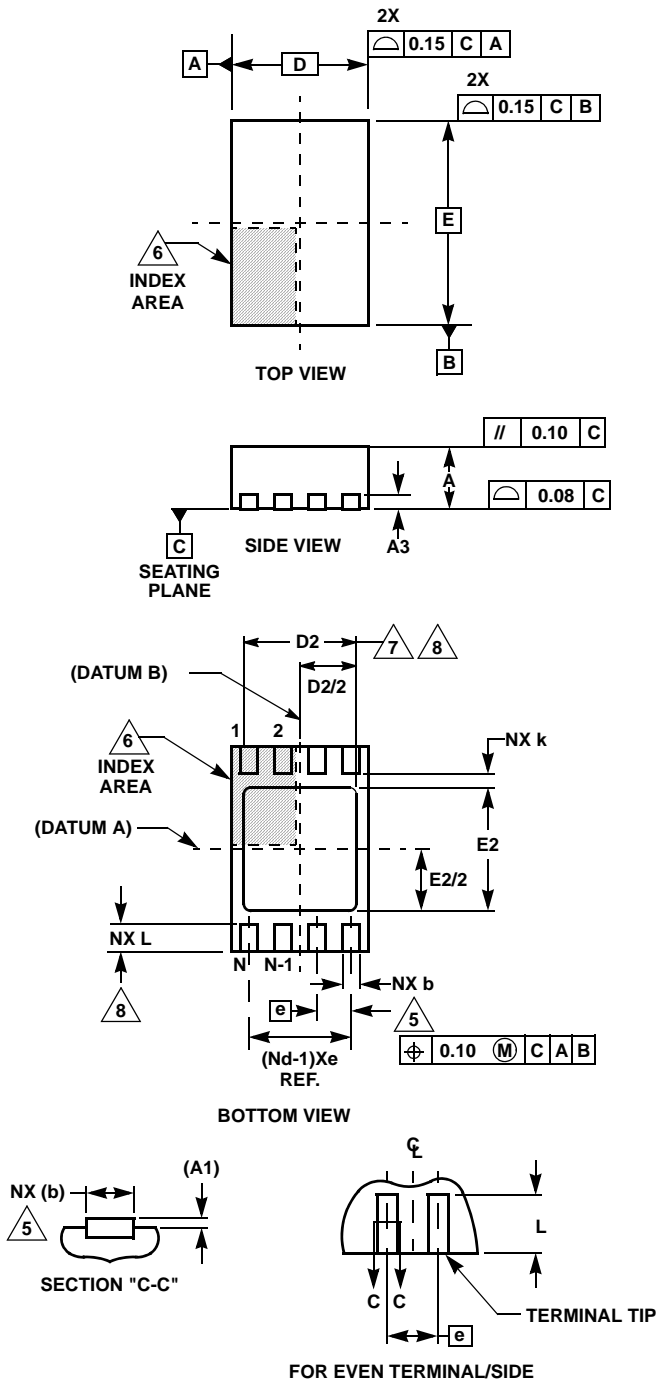

L8.2x3

8 LEAD DUAL FLAT NO-LEAD PLASTIC PACKAGE

SYMBOL	MILLIMETERS			NOTES
	MIN	NOMINAL	MAX	
A	0.80	0.90	1.00	-
A1	-	-	0.05	-
A3	0.20 REF			-
b	0.20	0.25	0.32	5,8
D	2.00 BSC			-
D2	1.50	1.65	1.75	7,8
E	3.00 BSC			-
E2	1.65	1.80	1.90	7,8
e	0.50 BSC			-
k	0.20	-	-	-
L	0.30	0.40	0.50	8
N	8			2
Nd	4			3

Rev. 0 6/04

NOTES:

1. Dimensioning and tolerancing conform to ASME Y14.5-1994.
2. N is the number of terminals.
3. Nd refers to the number of terminals on D.
4. All dimensions are in millimeters. Angles are in degrees.
5. Dimension b applies to the metallized terminal and is measured between 0.25mm and 0.30mm from the terminal tip.
6. The configuration of the pin #1 identifier is optional, but must be located within the zone indicated. The pin #1 identifier may be either a mold or mark feature.
7. Dimensions D2 and E2 are for the exposed pads which provide improved electrical and thermal performance.
8. Nominal dimensions are provided to assist with PCB Land Pattern Design efforts, see Intersil Technical Brief TB389.

All Intersil U.S. products are manufactured, assembled and tested utilizing ISO9000 quality systems. Intersil Corporation's quality certifications can be viewed at www.intersil.com/design/quality

Intersil products are sold by description only. Intersil Corporation reserves the right to make changes in circuit design, software and/or specifications at any time without notice. Accordingly, the reader is cautioned to verify that data sheets are current before placing orders. Information furnished by Intersil is believed to be accurate and reliable. However, no responsibility is assumed by Intersil or its subsidiaries for its use; nor for any infringements of patents or other rights of third parties which may result from its use. No license is granted by implication or otherwise under any patent or patent rights of Intersil or its subsidiaries.

For information regarding Intersil Corporation and its products, see www.intersil.com