

## Li-ion/Li-Polymer Battery Charger Accepting Two Power Sources

The ISL6299A is a fully integrated low-cost single-cell Li-ion or Li-polymer battery charger. The charger accepts two power inputs, normally one from a USB (Universal Serial Bus) port and the other from a desktop cradle. The ISL6299A is an ideal charger for smart handheld devices that need to communicate with a personal computer via USB.

The ISL6299A features 28V and 7V maximum voltages for the cradle and the USB inputs respectively. Due to the 28V rating for the cradle input, low-cost, large output tolerance adapters can be used safely. When both inputs are powered, the cradle input is used to charge the battery. The charge current is programmable for the cradle input with a small resistor. The end-of-charge current for the cradle input is also programmable by another external resistor. The charger incorporates Thermaguard™ which protects the IC against over temperature. If the die temperature rises above a typical value of 100°C, a thermal foldback function reduces the charge current automatically to prevent further temperature rise. The charger preconditions the battery with low current when the battery voltage is below 2.6V. The charger has two indication pins. The PPR (power present) pin outputs an open-drain logic LOW when either the cradle or the USB input power is attached. The CHG (charge) pin is also an open-drain output that indicates a logic LOW when the charge current is above a minimum current level. When the charge current is below the minimum current, the CHG pin indicates a logic HIGH signal and the status is latched. The latch will be reset at one of these events: (1) the part is disabled and re-enabled; (2) the selected input source has been removed and re-applied, (3) The USBON turns LOW, or (4) The BAT pin voltage falls below the recharge threshold (~4.0V).

### Ordering Information

PART #	PART MARKING	TEMP. RANGE (°C)	PACKAGE	PKG. DWG. #
ISL6299AIRZ (Note)	99AZ	-40 to 85	10 Ld 3x3 DFN (Pb-free)	L10.3x3C
ISL6299AIRZ-T (Note)	99AZ		10 Ld 3x3 DFN Tape and Reel (Pb-free)	

NOTE: Intersil Pb-free plus anneal products employ special Pb-free material sets; molding compounds/die attach materials and 100% matte tin plate termination finish, which are RoHS compliant and compatible with both SnPb and Pb-free soldering operations. Intersil Pb-free products are MSL classified at Pb-free peak reflow temperatures that meet or exceed the Pb-free requirements of IPC/JEDEC J STD-020.

### Features

- Complete Charger for Single-Cell Li-ion/Polymer Batteries
- **Dual Input Power Sources for Cradle and USB**
- **Low Component Count**
- Integrated Pass Element
- Fixed 380mA USB Charge Current
- Programmable Cradle Charge Current
- **Charge Current Thermaguard™ for Thermal Protection**
- **28V Maximum Voltage for the Cradle Input**
- Charge Indication
- Adapter Presence Indication
- Less than 0.5µA Leakage Current off the Battery when No Input Power Attached
- Programmable end-of-charge current with latch for Cradle Input
- Ambient Temperature Range: -40°C to 85°C
- No External Blocking Diode Required
- Pb-Free Plus Anneal Available (RoHS Compliant)

### Applications

- Smart Handheld Devices
- Cell Phones, PDAs, MP3 Players
- Digital Still Cameras
- Handheld Test Equipment

### Related Literature

- Technical Brief TB363 "Guidelines for Handling and Processing Moisture Sensitive Surface Mount Devices (SMDs)"
- Technical Brief TB389 "PCB Land Pattern Design and Surface Mount Guidelines for QFN Packages"

### Pinout

ISL6299A (DFN)  
TOP VIEW

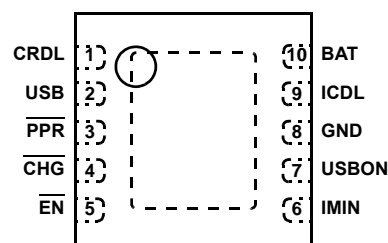

Block Diagram

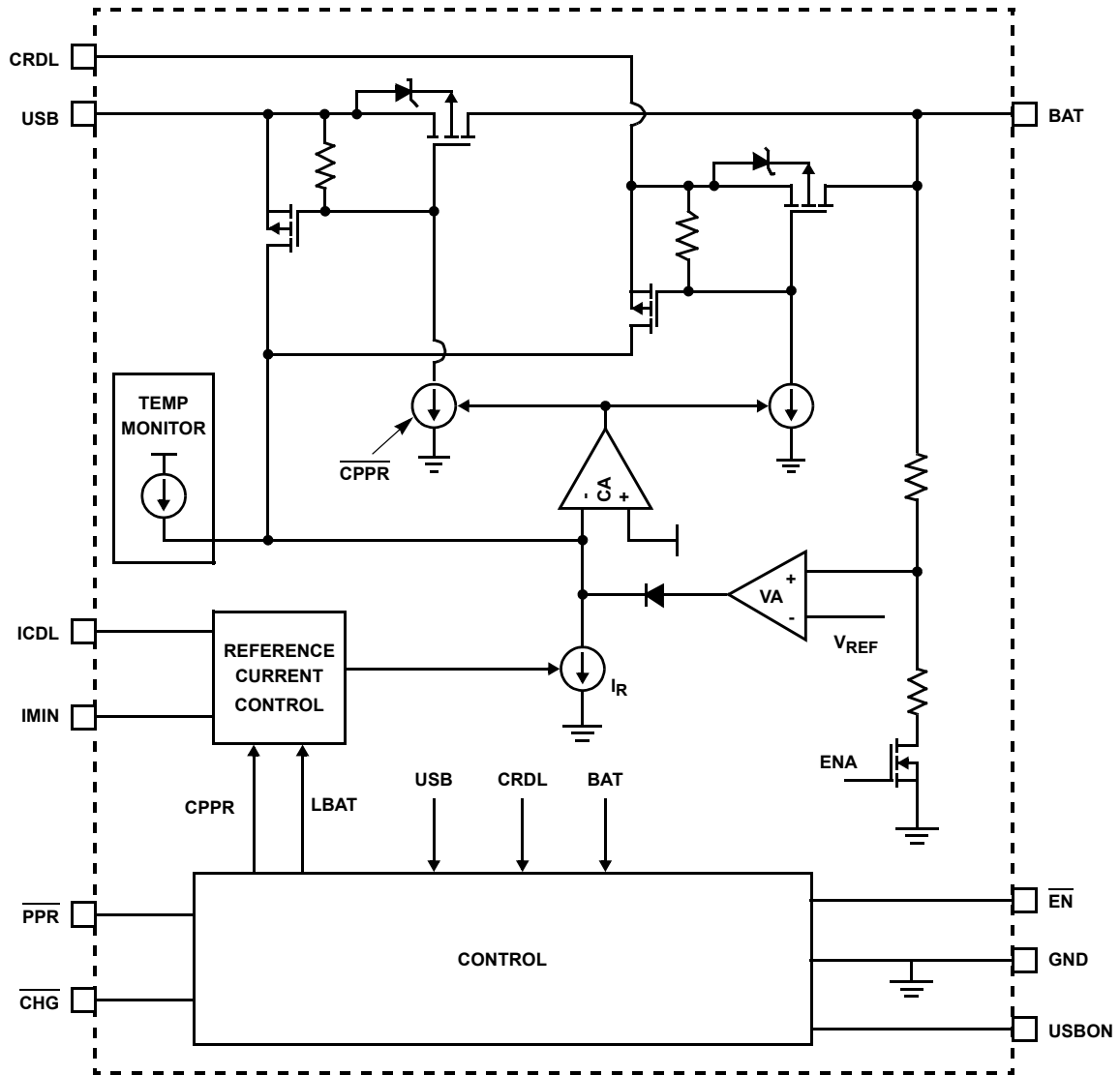

**Typical Applications**

**A Simple Charger Accepting Power from Both a USB Port and a Desktop Cradle**

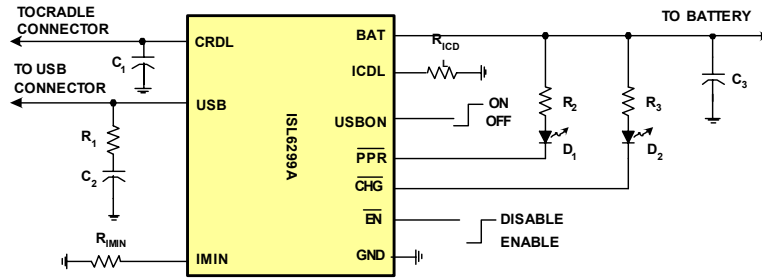

**COMPONENT SELECTION**

$R_{ICDL}$	28.71k $\Omega$ for 0.55A cradle charge current
$R_{IMIN}$	158k $\Omega$ for 80mA end-of-charge current
$R_2, R_3$	350 $\Omega$
$C_1, C_2, C_3$	1 $\mu$ F ceramic capacitor
$R_1$	1 $\Omega$
$D_1, D_2$	LEDs

**A Simple Charger with Programmable Charge Current and Wide Input Voltage Range**

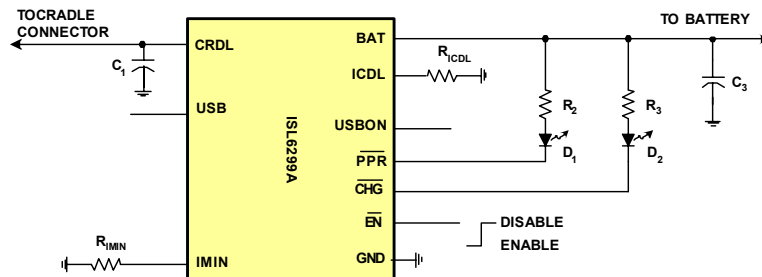

**COMPONENT SELECTION**

$R_{ICDL}$	28.71k $\Omega$ for 0.55A cradle charge current
$R_{IMIN}$	158k $\Omega$ for 80mA end-of-charge current
$R_2, R_3$	350 $\Omega$
$C_1, C_3$	1 $\mu$ F ceramic capacitor
$R_1$	1 $\Omega$
$D_1, D_2$	LEDs

**Absolute Maximum Ratings**

Supply Voltage (USB) .....	-0.3V to 7V
Supply Voltage (CRDL) .....	-0.3V to 28V
Other Input Voltage (EN, USBON, ICDL, IMIN, BAT) ...	-0.3V to 7V
Open-Drain Pull-Up Voltage (PPR, CHG) .....	-0.3V to 7V

**Thermal Information**

Thermal Resistance	$\theta_{JA}$ (°C/W)	$\theta_{JC}$ (°C/W)
DFN Package (Notes 1, 2) .....	40	2.5
Maximum Junction Temperature (Plastic Package) .....	150°C	
Maximum Storage Temperature Range .....	-65°C to 150°C	
Maximum Lead Temperature (Soldering 10s) .....	300°C	

**Recommended Operating Conditions**

Ambient Temperature Range .....	-40°C to 85°C
Supply Voltage (USB Pin) .....	4.3V to 5.5V
Supply Voltage (CRDL Pin) .....	4.3V to 24V
Typical Cradle Charge Current .....	300mA to 1A
Typical USB Charge Current .....	380mA

*CAUTION: Stresses above those listed in "Absolute Maximum Ratings" may cause permanent damage to the device. This is a stress only rating and operation of the device at these or any other conditions above those indicated in the operational sections of this specification is not implied.*

**NOTES:**

1.  $\theta_{JA}$  is measured in free air with the component mounted on a high effective thermal conductivity test board with "direct attach" features. See Tech Brief TB379.
2. For theta  $\theta_{JC}$  the "case temp." location is the center of the exposed metal pad on the package underside.

**Electrical Specifications** Typical Values Are Tested at USB = CRDL = 5V and ambient temperature is at 25°C, Unless Otherwise Noted. All Maximum and Minimum Values Are Guaranteed Under the Recommended Operating Conditions.

PARAMETER	SYMBOL	TEST CONDITIONS	MIN	TYP	MAX	UNITS
<b>POWER-ON RESET</b>						
Rising USB/CRDL Threshold			3.4	3.9	4.2	V
Falling USB/CRDL Threshold			3.2	3.7	4.0	V
<b>VIN-BAT OFFSET VOLTAGE</b>						
Rising Edge	$V_{OS}$	$V_{BAT} = 4.0V$ , use CHG pin to indicate the comparator output (Note 3)	-	150	250	mV
Falling Edge	$V_{OS}$		20	80	-	mV
<b>STANDBY CURRENT</b>						
BAT Pin Sink Current	$I_{STANDBY}$	EN = HIGH or both inputs are floating	-	0.05	0.5	$\mu A$
CRDL Pin Supply Current	$I_{CRDL}$	EN = HIGH	-	150	220	$\mu A$
USB Pin Supply Current	$I_{USB}$		-	150	220	$\mu A$
CRDL/USB Pin Supply Current		EN = LOW or floating	-	0.4	0.8	mA
<b>VOLTAGE REGULATION</b>						
Output Voltage (Note 4)	$V_{CH}$	Load = 10mA	4.158	4.2	4.242	V
CRDL PMOS On Resistance (Note 8)		$V_{BAT} = 3.8V$ , $I_{CHARGER} = 0.3A$	200	600	900	$m\Omega$
USB PMOS On Resistance (Note 8)		$V_{BAT} = 3.8V$ , $I_{CHARGER} = 0.3A$	200	700	900	$m\Omega$
<b>CHARGE CURRENT (Note 5)</b>						
ICDL Pin Output Voltage	$V_{ICDL}$	$V_{BAT} = 3.8V$	1.17	1.20	1.23	V
CRDL Input Constant Charge Current	$I_{CHARGE}$	$R_{ICDL} = 28.7k\Omega$ , $V_{BAT} = 3.8V$ , $V_{CRDL} = 5V$	500	550	600	mA
CRDL Input Trickle Charge Current	$I_{TRICKLE}$	$R_{ICDL} = 28.7k\Omega$ , $V_{BAT} = 2.0V$ , $V_{CRDL} = 5V$ Given as a % of the CRDL $I_{CHARGE}$	11	15	19	%
CRDL End-of-Charge Threshold	$I_{MIN}$	$R_{IMIN} = 158k\Omega$	69	88	107	mA
USB Input Constant Charge Current (Note 6)	$I_{CHARGE}$	USBON = HIGH, $V_{BAT} = 3.8V$	325	380	425	mA
USB Input Trickle Charge Current (Note 4)	$I_{TRICKLE}$	$V_{BAT} = 2.0V$ , given as a % of the USB $I_{CHARGE}$	12	14	17	%
USB End-of-Charge Threshold	$I_{MIN}$		64	76	84	mA

# ISL6299A

**Electrical Specifications** Typical Values Are Tested at USB = CRDL = 5V and ambient temperature is at 25°C, Unless Otherwise Noted. All Maximum and Minimum Values Are Guaranteed Under the Recommended Operating Conditions. **(Continued)**

PARAMETER	SYMBOL	TEST CONDITIONS	MIN	TYP	MAX	UNITS
<b>PRECONDITIONING CHARGE THRESHOLD</b>						
Preconditioning Charge Threshold Voltage	V <sub>MIN</sub>		2.5	2.6	2.7	V
<b>INTERNAL TEMPERATURE MONITORING</b>						
Current Foldback Threshold (Note 7)	T <sub>FOLD</sub>		85	100	115	°C
<b>LOGIC INPUT AND OUTPUT</b>						
USBON Logic Input High			1.3	-	-	V
USBON Logic Input LOW			-	-	0.4	V
EN Pin Logic Input High			1.3	-	-	V
EN Pin Logic Input Low			-	-	0.4	V
EN Pin Internal Pull Down Resistance			350	600	850	kΩ
USBON Pin internal Pull Down Resistance			700	1000	1300	kΩ
CHG/PPR Sink Current		Pin Voltage = 0.8V	10	-	-	mA

**NOTES:**

- The 4.0V V<sub>BAT</sub> is selected so that the CHG output can be used as the indication for the offset comparator output indication. If the V<sub>BAT</sub> is lower than the POR threshold, no output pin can be used for indication.
- The maximum and minimum limits are guaranteed over -40°C to 70°C ambient temperature range.
- The charge current can be affected by the thermal foldback function if the IC under the test setup cannot dissipate the heat.
- Constant current can be affected if the junction temperature exceeds 70 °C.
- Guaranteed by characterization or correlation to other test.
- Tested at T<sub>J</sub> = 25°C.

## Functional Pin Description

### CRDL (Pin 1)

Cradle input. This pin is usually connected to a cradle power input. The maximum input voltage is 28V. The charge current from this pin is programmable with the ICDL pin up to 1A. When this pin is connected to a power source, no charge current is drawn from the USB pin. A 1μF or larger value ceramic capacitor is recommended for decoupling.

### USB (Pin 2)

USB input. This pin is usually connected to a USB port power connector. Other sources that are lower than 5.5V are also acceptable. The charge current from the USB pin is fixed at typically 380mA. A 1μF or larger value ceramic capacitor is recommended for decoupling. It is also recommended to have a 1Ω resistor in series with the decoupling capacitor to prevent an over-shoot voltage when a USB cable is plugged in.

### PPR (Pin 3)

Power presence indication. An open-drain output pin which turns ON when either the USB input voltage or the CRDL input voltage is above its POR level, regardless if the charger is enabled or disabled. Otherwise turns OFF. This pin provides a wake-up signal to a microprocessor when either the cradle or the USB power is connected.

### CHG (Pin 4)

Charge indication pin. An open-drain output which turns ON when the charge current from the cradle input is above programmable I<sub>MIN</sub> or when the charge current from the USB input is above the fixed end of charge current threshold. Otherwise turns OFF.

### EN (Pin 5)

Enable logic input. Connect to LOW or leave floating to enable the charger.

### IMIN (Pin 6)

IMIN is the programmable input for the end-of-charge current. IMIN is calculated by the following equation:

$$I_{MIN} = \frac{14478}{R_{IMIN}} - 4 \quad (\text{mA})$$

Where R<sub>IMIN</sub> is in kΩ. IMIN is only applicable to the cradle charging. The USB EOC current has been fixed as shown on the electrical specification table.

**USBON (Pin 7)**

The USBON pin is a control input to turn off the USB charge function if desired. Connect to LOW or leave floating to turn off USB charge.

**GND (Pin 8)**

System ground.

**ICDL (Pin 9)**

The ICDL pin has two functions. The first function is to program the cradle charge current during the constant-current mode. The voltage of this pin is 1.22V during the constant-current mode of the cradle charger. The constant-current mode current is programmed by the following equations:

$$I_{CLD} = \frac{16685.5}{R_{ICDL}} - 0.026 \quad 0.1A < I_{CLD} < 0.7A$$

$$I_{CDL} = \frac{21242.1}{R_{ICDL}} - 0.188 \quad 0.7A < I_{CDL} < 1.1A$$

where  $R_{ICDL}$  is the resistor in  $\Omega$ , connected to the ICDL pin (see the Typical Application).

It is recommended that the charge current be programmed in the range of 350mA to 650mA.

The second function of the ICDL pin is to monitor the actual charge current. The voltage of this pin,  $V_{ICDL}$ , is proportional to the actual charge current,  $I_{CHG}$

The cradle charge current should be programmed equal or higher than the USB current; otherwise, the ICDL pin voltage will be higher than 1.22V during the constant current mode when the USB charger is working. The charger still works properly but the accuracy of the current monitoring voltage degrades and saturates at approximately 2.1V.

**BAT (Pin 10)**

Charger output pin. Connect this pin to the battery pack or the battery cell. A 1 $\mu$ F or larger value ceramic capacitor is recommended for decoupling. The charger relies on the battery for stability so a battery should always be connected to the BAT pin.

**Description**

The ISL6299A is designed for a single-cell Li-ion or Li-polymer battery charging circuit that accepts both a USB port and a desktop cradle as its power source. While the charge current from the USB input source is fixed at 380mA, the charge current from the cradle input is programmable between 0.1A and 1.0A by the resistor  $R_{ICDL}$ . Similarly, the end-of-charge current is fixed at typically 80mA for the USB input and programmable for the cradle input by the resistor  $R_{IMIN}$ .

**Input Auto Selection**

When both input sources are present, the charger selects only one power source to charge the battery. When the CRDL input is higher than the POR threshold, CRDL is selected as the power source. Otherwise the USB input is selected. If the CRDL input voltage is below the battery voltage but the USB input voltage is higher than the battery voltage, then the USB input is used to charge the battery. The control circuit always breaks both internal power devices before switching from one power source to the other to avoid a cross conduction of both power MOSFETs.

**USB Charge Current**

When the USB port is selected as the power source, the charge current enabled by the logic input at the USBON pin. When the USBON is driven to logic LOW, the charger is disabled. When the USBON is driven to logic HIGH, the charge current is fixed at a typical value of 380mA. Thus for the USB input, the USBON pin has a similar function as the EN pin. The following table describes the USB charge control by both the USBON pin and EN pin:

**TABLE 1. USB CHARGE CONTROL**

	EN = LOW	EN = HIGH
USBON = LOW	Disabled	Disabled
USBON = HIGH	Enabled	Disabled

The USBON pin is equivalent to a logic LOW when left floating. Typically the P-channel MOSFET for the USB input has an  $r_{DS(ON)}$  of 700m $\Omega$  at room temperature. With a 380mA charge current, the typical head room is 260mV. Thus, if the input voltage drops to a level that the voltage difference between the USB pin and the BAT pin is less than 260mV, the  $r_{DS(ON)}$  becomes a limiting factor of the charge current; and the charger drops out the constant current regulation.

**Cradle Charge Current**

The cradle charge current is enabled by the EN pin only, the USBON pin has no control on the cradle charge current. The cradle charge current is programmed with the external resistor connected between the ICDL pin and the GND pin. The current can be calculated with one of the equations given in the ICDL pin description. Two equations are used for the cradle current calculation, each corresponds to a different range of currents. The typical  $r_{DS(ON)}$  of the P-channel MOSFET for the CRDL input is 600m $\Omega$  at room temperature. When the head room between the input and output voltages is small, the actual charge current, similar to the USB case, could be limited by the  $r_{DS(ON)}$ . On the other hand, if the head room between the input and output voltages is large, the charge current may be limited by the thermal foldback threshold.

**Floating Charge Voltage**

The floating voltage during the constant voltage phase is 4.2V. The floating voltage has an 1% accuracy over the ambient temperature range of -40°C to 70°C.

**Trickle Charge Current**

When the battery voltage is below the minimum battery voltage  $V_{MIN}$  given in the electrical specification, the charger operates in a trickle/preconditioning mode, where the charge current is typically 14% of the programmed charge current for the cradle input. If power comes from the USB input, the trickle mode current is approximately 53mA.

**End-of-Charge Indication**

The CHG pin internal open-drain MOSFET turns off when the charge current falls below the  $I_{MIN}$  threshold, which is programmable for the cradle input and fixed for the USB input. Once the end-of charge-current is reached, the CHG status will be latched. The latch can be reset at one of the following conditions:

1. The part is disabled and re-enabled
2. The selected input source has been removed and re-applied
3. The USBON turns LOW and turns back to HIGH for the USB input
4. The BAT pin voltage falls below the recharge threshold (~4.0V)

Regardless of the CHG pin status, however, the charger does not turn off as long as an input power source is attached.

**Power Presence Indication**

When either the USB or the cradle input voltage is above the POR threshold, the PPR pin internal open-drain MOSFET turns on indicating the presence of input power.

**Power-Good Range**

Even if there is a power present, the charger will not deliver any current to the output if the power-good conditions are not met. The following two conditions together define the power-good voltage range:

1.  $VCDRL$  or  $VUSB > VPOR$
2.  $VCDRL$  or  $VUSB - VBAT > VOS$

where the VOS is the offset voltage for the input and output voltage comparator, discussed shortly. Both VPOR, VOS have hysteresis, as given in the Electrical Specification table. The charger will not charge the battery if the input voltage does not meet the power-good conditions.

**Thermal Foldback (Thermaguard™)**

The thermal foldback function reduces the charge current when the internal temperature reaches the thermal foldback threshold, which is typically 100°C. This protects the charger from excessive thermal stress at high input voltages.

Dual Flat No-Lead Plastic Package (DFN)

L10.3x3C

10 LEAD DUAL FLAT NO-LEAD PLASTIC PACKAGE

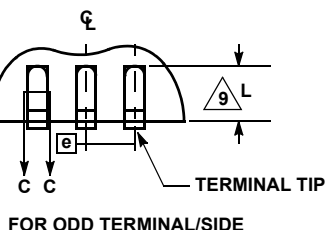
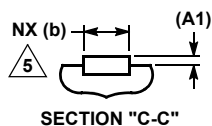
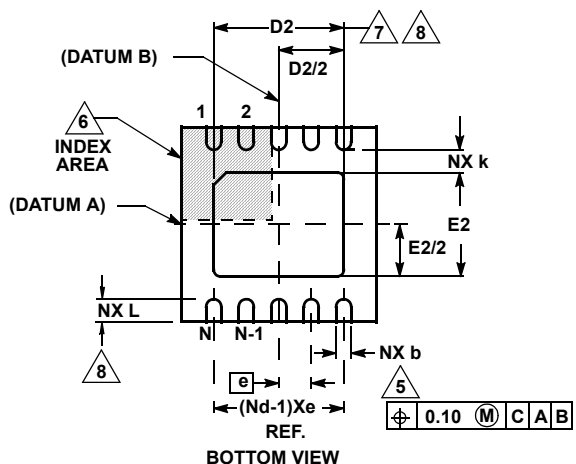
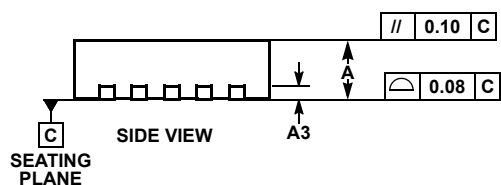
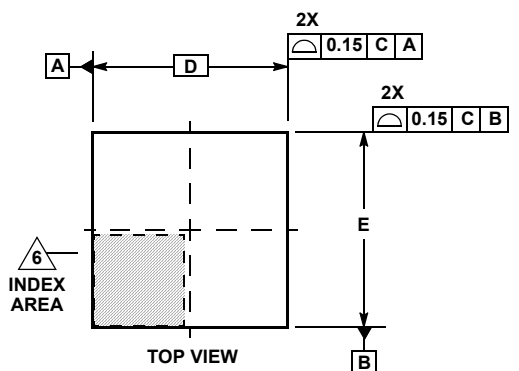

SYMBOL	MILLIMETERS			NOTES
	MIN	NOMINAL	MAX	
A	0.80	0.90	1.00	-
A1	-	-	0.05	-
A3	0.20 REF			-
b	0.18	0.25	0.30	5, 8
D	3.00 BSC			-
D2	2.23	2.38	2.48	7, 8
E	3.00 BSC			-
E2	1.49	1.64	1.74	7, 8
e	0.50 BSC			-
k	0.20	-	-	-
L	0.30	0.40	0.50	8
N	10			2
Nd	5			3

Rev. 0 3/05

NOTES:

1. Dimensioning and tolerancing conform to ASME Y14.5-1994.
2. N is the number of terminals.
3. Nd refers to the number of terminals on D.
4. All dimensions are in millimeters. Angles are in degrees.
5. Dimension b applies to the metallized terminal and is measured between 0.15mm and 0.30mm from the terminal tip.
6. The configuration of the pin #1 identifier is optional, but must be located within the zone indicated. The pin #1 identifier may be either a mold or mark feature.
7. Dimensions D2 and E2 are for the exposed pads which provide improved electrical and thermal performance.
8. Nominal dimensions are provided to assist with PCB Land Pattern Design efforts, see Intersil Technical Brief TB389.
9. COMPLIANT TO JEDEC MO-229-WEED-3 except for dimensions E2 & D2.

All Intersil U.S. products are manufactured, assembled and tested utilizing ISO9000 quality systems. Intersil Corporation's quality certifications can be viewed at [www.intersil.com/design/quality](http://www.intersil.com/design/quality)

Intersil products are sold by description only. Intersil Corporation reserves the right to make changes in circuit design, software and/or specifications at any time without notice. Accordingly, the reader is cautioned to verify that data sheets are current before placing orders. Information furnished by Intersil is believed to be accurate and reliable. However, no responsibility is assumed by Intersil or its subsidiaries for its use; nor for any infringements of patents or other rights of third parties which may result from its use. No license is granted by implication or otherwise under any patent or patent rights of Intersil or its subsidiaries.

For information regarding Intersil Corporation and its products, see [www.intersil.com](http://www.intersil.com)