

Li-ion/Li Polymer Battery Charger

The ISL6292B uses Intersil's **patent-pending** dual-mode charge technology to minimize the heat in a linear charger. The ISL6292B is a modification of the original ISL6292 and is optimized for cellular phone travel charger applications. The low-heat generation feature of the dual-mode charger enables the charger IC to be placed inside the connector of the travel charger to completely remove the influence of the adapter cable on the charging performance.

Working with a current-limited ac/dc converter, the dual-mode charger charges a Li-ion battery with the same current profile as a traditional linear charger. The constant charge current is determined by the current limit of the ac/dc converter. The constant output voltage is fixed at 4.2V. When the battery voltage is below 2.8V, the charger preconditions the battery with a low trickle-charge current. The charge status is indicated by a tri-color LED. A safety timer prevents charging a dead battery for an excessively long period.

The ISL6292B also features a thermal foldback function that automatically reduces the charge current when the internal die temperature exceeds a 100°C limit to prevent further temperature rise. This function removes the concern of thermal failure in the targeted space-limited applications. An ambient temperature monitoring circuit allows users to set two separate temperature limit levels, one for during charge and one for not during charge. The thermally-enhanced QFN package further improves the thermal performance of the ISL6292B in space-limited applications.

Ordering Information

PART NUMBER	TEMP. RANGE (°C)	PKG. DWG. #
ISL6292BCR*	-20 to 70	16 Ld 4x4 QFN
ISL6292BCRZ* (Note)	-20 to 70	16 Ld 4x4 QFN (Pb-free)

*Add "-T" suffix for tape and reel.

NOTE: Intersil Pb-free products employ special Pb-free material sets; molding compounds/die attach materials and 100% matte tin plate termination finish, which are RoHS compliant and compatible with both SnPb and Pb-free soldering operations. Intersil Pb-free products are MSL classified at Pb-free peak reflow temperatures that meet or exceed the Pb-free requirements of IPC/JEDEC J STD-020.

Pinout

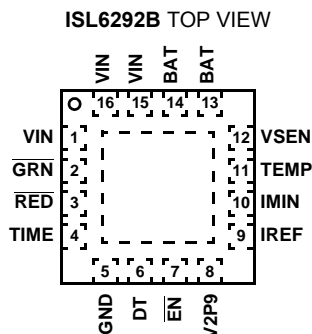

Features

- Complete Charger for Single-Cell Li-ion Batteries
- Integrated Pass Element and Current Sensor
- No External Blocking Diode Required
- **Very Low Thermal Dual-Mode Operation**
- 1% Voltage Accuracy with Remote Sense
- Programmable Current Limit up to 1.5A
- Programmable End-of-Charge Current
- Programmable Safety Timer
- Drives a Tri-Color LED
- **Charge Current Thermal Foldback**
- NTC Thermistor Interface for Battery Temperature Monitor
- **Two-Level Ambient Temperature Setting**
- Guaranteed to Operate at 2.65V After Start-Up
- Ambient Temperature Range: -20°C to 70°C
- Thermally-Enhanced QFN Packages
- QFN Package:
 - Compliant to JEDEC PUB95 MO-220 QFN - Quad Flat No Leads - Package Outline
 - Near Chip Scale Package footprint, which improves PCB efficiency and has a thinner profile
- Pb-Free Available (RoHS Compliant)

Applications

- Handheld Devices including Medical Handhelds
- PDAs, Cell Phones and Smart Phones
- Portable Instruments, MP3 Players
- Self-Charging Battery Packs
- Stand-Alone Chargers
- USB Bus-Powered Chargers

Related Literature

- Technical Brief TB363 "Guidelines for Handling and Processing Moisture Sensitive Surface Mount Devices (SMDs)"
- Technical Brief TB379 "Thermal Characterization of Packaged Semiconductor Devices"
- Technical Brief TB389 "PCB Land Pattern Design and Surface Mount Guidelines for QFN Packages"

Absolute Maximum Ratings

Supply Voltage (VIN)	-0.3 to 7V
Output Pin (BAT, VSEN, RED, GRN, DT)	-0.3 to 5.5V
Signal Pin (EN, TIME TEMP, IREF, IMIN, V2P9).....	-0.3 to 3.2V
Charge Current	1.6A
ESD Rating	
Human Body Model (Per MIL-STD-883 Method 3015.7) . . .	3500V
Machine Model (Per EIAJ ED-4701 Method C-111)	200V

Thermal Information

Thermal Resistance (Notes 1, 2)	θ_{JA} (°C/W)	θ_{JC} (°C/W)
4x4 QFN Package	41	4
Maximum Junction Temperature (Plastic Package)	150°C	
Maximum Storage Temperature Range	-65°C to 150°C	
Maximum Lead Temperature (Soldering 10s)	300°C	

Recommended Operating Conditions

Ambient Temperature Range	-20°C to 70°C
Supply Voltage, VIN	4.3V to 6.5V
Recommended Charge Current	400mA to 1.5A

CAUTION: Stresses above those listed in "Absolute Maximum Ratings" may cause permanent damage to the device. This is a stress only rating and operation of the device at these or any other conditions above those indicated in the operational sections of this specification is not implied.

NOTES:

- θ_{JA} is measured in free air with the component mounted on a high effective thermal conductivity test board with "direct attach" features. See Tech Brief TB379.
- θ_{JC} , "case temperature" location is at the center of the exposed metal pad on the package underside. See Tech Brief TB379.

Electrical Specifications

Typical values are tested at VIN = 5V and 25°C Ambient Temperature, maximum and minimum values are guaranteed over -10°C to 70°C Ambient Temperature with a supply voltage in the range of 4.3V to 6.5V, unless otherwise noted.

PARAMETER	SYMBOL	TEST CONDITIONS	MIN	TYP	MAX	UNITS
POWER-ON RESET						
Rising VIN Threshold			3.0	3.4	4.0	V
Falling VIN Threshold			2.3	2.4	2.7	V
STANDBY CURRENT						
VBAT Pin Sink Current	I _{STANDBY}	VIN floating or EN pin is floating	-	-	3.0	μA
VIN Pin Supply Current	I _{VIN}	BAT Pin floating, EN = LOW	-	0.5	-	mA
VOLTAGE REGULATION						
Output Voltage	V _{CH}		4.158	4.20	4.242	V
Dropout Voltage		V _{BAT} = 3.7V, I _{CHARGE} = 0.65A	-	190	-	mV
CHARGE CURRENT						
Charge/Protection Current (Note 3)	I _{CHARGE}	R _{IREF} = 80kΩ, V _{BAT} = 3.7V, V _{IN} = 5V	0.9	1.0	1.1	A
Trickle Charge Current	I _{TRICKLE}	R _{IREF} = 80kΩ, V _{BAT} = 2.0V, V _{IN} = 5V	85	110	135	mA
End-of-Charge Threshold		R _{IMIN} = 133kΩ	40	60	80	mA
RECHARGE THRESHOLD						
Recharge Voltage Threshold	V _{RECHRG}		3.85	4.00	4.13	V
TRICKLE CHARGE THRESHOLD						
Trickle Charge Threshold Voltage	V _{MIN}		2.7	2.8	3.2	V
BATTERY TEMPERATURE MONITORING						
Low Temperature Threshold	V _{TMIN}	V2P9 = 3.0V	1.44	1.50	1.58	V
Low Temperature Hysteresis (Note 4)			-	214	-	mV
High Temperature Threshold	V _{TMAX}	V2P9 = 3.0V	0.35	0.38	0.405	V
High Temperature Hysteresis (Note 4)			-	51.4	-	mV
DT Pin MOSFET On Resistance	R _{DT}		-	30	100	Ω
Charge Current Foldback Threshold (Note 4)	T _{FOLD}		85	100	115	°C
Current Foldback Gain (Note 4)	G _{FOLD}		-	100	-	mA/°C

ISL6292B

Electrical Specifications Typical values are tested at $V_{IN} = 5V$ and $25^{\circ}C$ Ambient Temperature, maximum and minimum values are guaranteed over $-10^{\circ}C$ to $70^{\circ}C$ Ambient Temperature with a supply voltage in the range of 4.3V to 6.5V, unless otherwise noted. **(Continued)**

PARAMETER	SYMBOL	TEST CONDITIONS	MIN	TYP	MAX	UNITS
OSCILLATOR						
Oscillation Period	T_{OSC}	$C_{TIME} = 15nF$	2.4	3.0	3.6	ms
LOGIC INPUT AND OUTPUT						
EN Input Low			-	-	0.8	V
EN Pin External Pull Down to Disable			-	-	50	$k\Omega$
RED Sink Current		Pin Voltage = 0.8V	5	-	-	mA
GRN Sink Current		Pin Voltage = 0.8V	5	-	-	mA

NOTES:

3. The actual current may be lower due to the thermal foldback.
4. Guaranteed by design, not a tested parameter.

Pin Description

VIN

VIN is the input power source. Connect to a wall adapter.

RED, GRN

RED and GRN are two open-drain outputs to drive a red and a green LED in the same package. The RED and the GRN pins are guaranteed to be capable of sinking at least 5mA current.

TIME

The TIME pin determines the oscillation period by connecting a timing capacitor between this pin and GND. The oscillator provides a time reference for the charger.

GND

GND is the connection to system ground.

V2P9

This is a 2.9V untrimmed voltage output. This pin outputs a 2.9V voltage source when the input voltage is above POR threshold, independent on the EN pin input. The V2P9 pin can be used as an indication for adapter presence.

EN

EN is the enable logic input. Connect the EN pin to LOW to enable the charger or leave it floating to disable the charger. This pin is pulled up to 2.9V when left floating.

IREF

This is the programming input for the constant charging current in a linear charger. In the typical application of a dual-mode charger, the IREF pin programs the trickle charge current as well as the protection current level.

IMIN

IMIN is the programmable input for the end-of-charge current.

TEMP

TEMP is the input for an external NTC thermistor.

DT

DT is the input to set the temperature difference before and after the charging starts. This pin can also be used as an indication whether or not the charger is charging.

VSEN

VSEN is the battery voltage sensing input. This pin allows remote sense of the battery pack voltage.

BAT

BAT is the charger output.

Typical Application

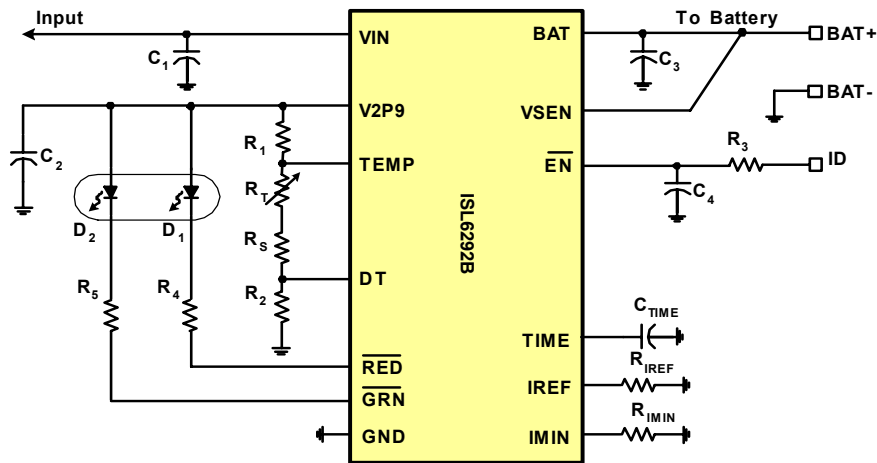

- C₁, C₃: 1μF X5R ceramic capacitor
- C₂, C₄: 0.1μF X5R ceramic capacitor
- C_{TIME}: 22nF X5R or better timing capacitor
- D₁, D₂: dual-color (red and green) LED in one package
- R_{IREF}: 80kΩ, 1%
- R_{IMIN}: 133kΩ, 1%

- R₁: 41.2kΩ, 1%
- R₂: TBD, value dependent on the ΔT (2.3kΩ for 20°C)
- R_T: ECTH-160808-103-J-3800HT, 10kΩ at 25°C, 5%
- R_S: 1.33kΩ, 1%
- R₃: 10kΩ, 5% (R₃ and C₄ are for improving ESD protection)
- R₄, R₅: 330Ω, 5%

Block Diagram

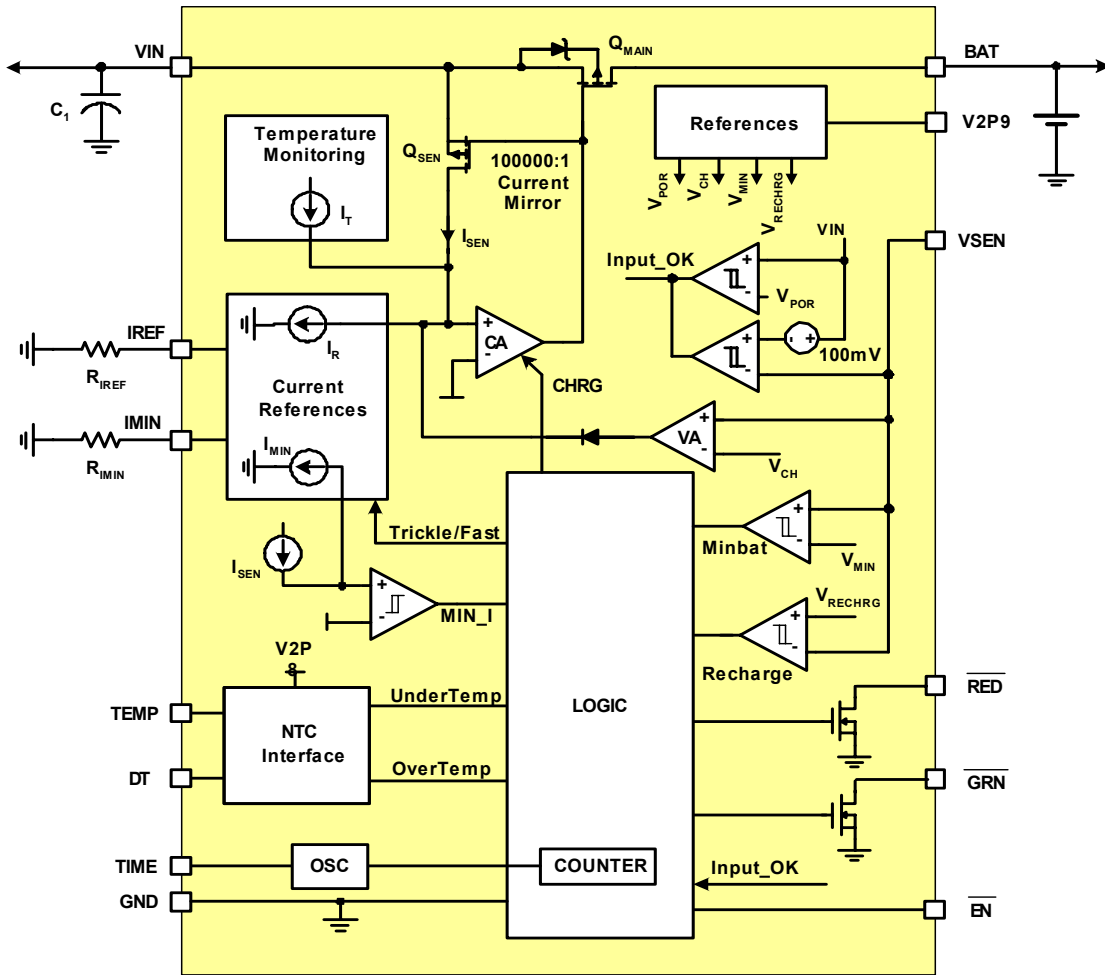

Flow Chart

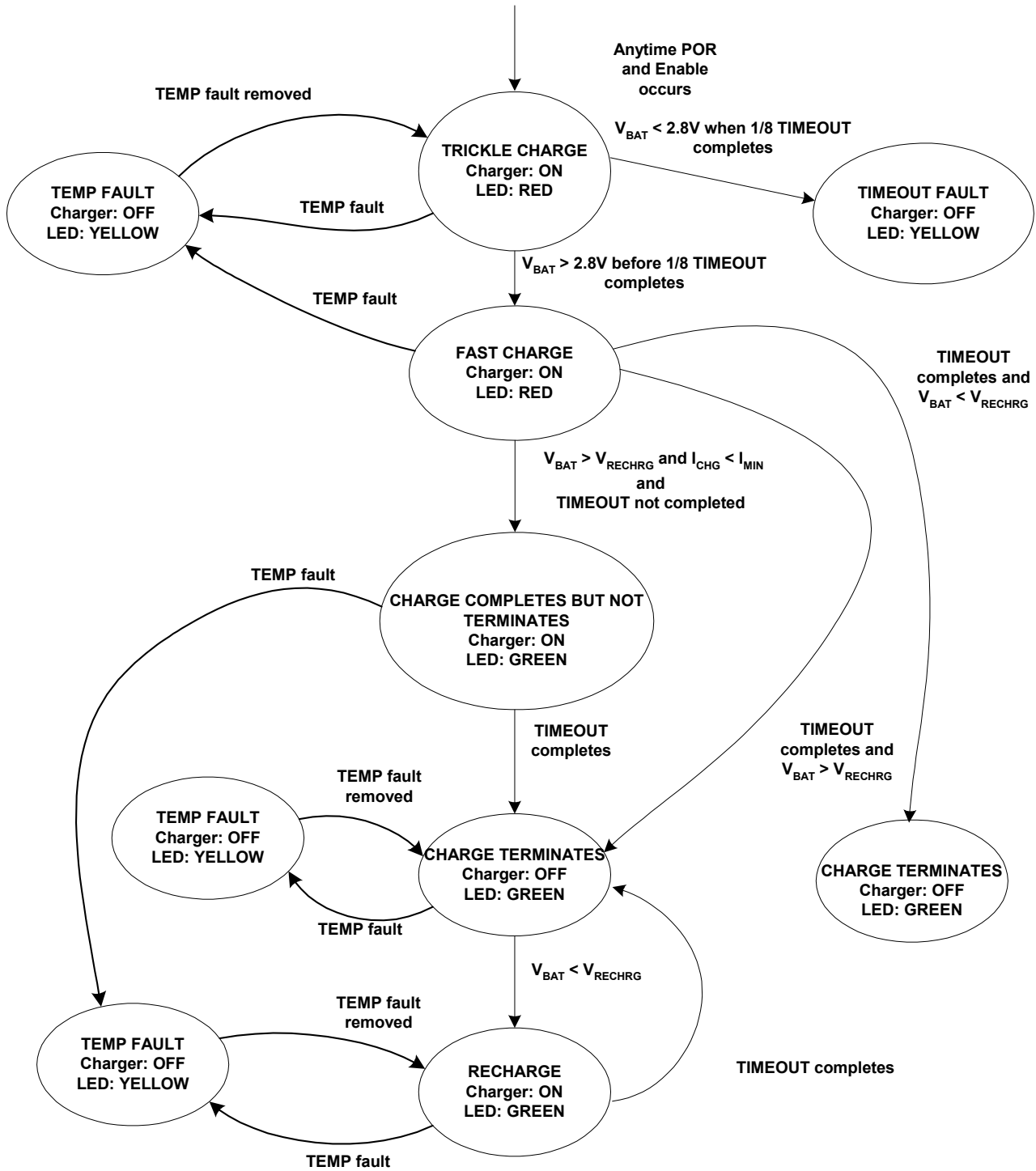

Theory of Operation

The ISL6292B is based on the **Intersil Patent-pending** dual-mode charging technology. The dual-mode technology generates very low heat, which enables the charger to be used in space-limited applications.

To take advantage of the low-heat feature, a current-limited ac/dc converter is required as the power supply to the charger. The current-limited supply has the I-V characteristics shown in Figure 1. The supply is a dc source before the load current reaches the limited current I_{LIM} . Once the current limit is reached, the supply current cannot increase further; instead, the supply voltage falls. The current-limited supply is equivalent to a voltage source with an equivalent output impedance or a current source, depending on the region it operates at, as shown in Figure 1.

The ISL6292B charges a battery with the traditional constant current/constant voltage (CC/CV) profile. The constant current is determined by the current limit I_{LIM} of the supply during the constant-current charge mode. To ensure dual-mode operation, the current protection level set by the IREF pin should be higher than I_{LIM} . In the constant-voltage charge mode, the battery voltage is regulated at 4.2V. When the battery voltage is below the V_{MIN} given in the Electrical Specification, the charger preconditions the battery using trickle charge mode. The trickle-charge current is 10% of the protection current level programmed by the IREF pin.

Figure 2 shows the typical waveforms in a charge cycle of the dual mode operation. When the battery is below V_{MIN} , the charge current is 10% of I_{REF} set by the IREF pin. Since the charge current is much less than the I_{LIM} , the ac/dc converter operates in the voltage source region. Once the battery voltage exceeds V_{MIN} , the charger starts to fully turn on the internal P-channel power MOSFET. The ac/dc converter operates in the current-limited region and its voltage is pulled down to a level slightly higher than the battery voltage. As shown in Figure 2, the charge current is I_{LIM} and is lower than I_{REF} . As the battery voltage reaches the 4.2V V_{CH} , the charge current starts to decrease. The ac/dc supply moves out of the current-limit region and

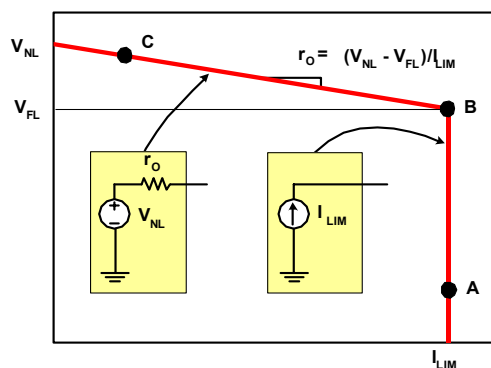

FIGURE 1. THE I-V CHARACTERISTICS OF THE CURRENT-LIMITED AC/DC CONVERTER.

becomes a voltage source again. When the charge current reaches a programmable end-of-charge (EOC) level set by the IMIN pin, the charger sends out an EOC indication. The real termination of the charger happens at the end of a total charge time set by the TIME pin.

The power dissipation is also shown in Figure 2. The power dissipation in both the trickle mode and the constant-current (CC) mode are very low. The possible peak power occurs at the transition from the CC mode to the constant-voltage (CV) mode. This peak power is much lower than the peak power normally seen in a linear charger and can be further reduced by properly designing the ac/dc converter. One simple approach is to design the ac/dc converter output voltage just high enough to fully charge the battery (normally lower than 5V). More information can be found in the ISL6292 datasheet available at <http://www.intersil.com>. To ensure the thermal safety, the ISL6292B has an internal thermal fold-back function that automatically reduces the charge current if the internal temperature typically rises above 100°C.

The ISL6292B offers many other features. The trickle current, the CC charge current, and the end-of-charge (EOC) current are all programmable. A thermal foldback function monitors the internal temperature and reduces the charge current when the internal temperature rises above 100°C to prevent further temperature rise. A safety timer sets the charge time limit for both trickle mode and fast mode charge. When the battery voltage drops after the charge cycle terminates, the charger automatically starts recharging the battery to full. Two indication pins are designed to drive a tri-color LED (a red and a green LED in the same package). A simple thermistor circuit interface allows the user to set a different level of ambient temperature before and after the charger starts. All these features are described in detail in the Application Information section.

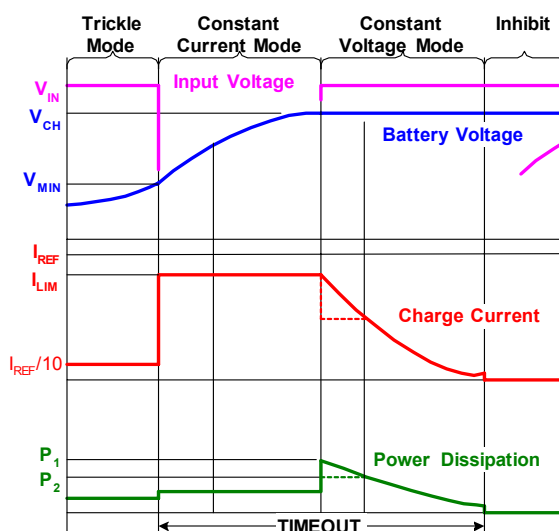

FIGURE 2. TYPICAL CHARGE CURVES USING A CURRENT-LIMITED ADAPTER.

Applications Information

Power-On Reset (POR)

The ISL6292B has a 3.4V rising POR threshold. Before the input voltage reaches the POR threshold, the 2.9V V2P9 pin outputs 0V and the charger is disabled. Once the POR threshold is reached, the V2P9 pin outputs 2.9V, the open-drain MOSFET on the DT pin is turned on, and the ambient temperature monitoring circuit starts to function. After a delay and after the input voltage rises above the battery voltage, the charger control circuit starts to work and the DT pin impedance becomes high. Figure 3 shows the sequence of the events at power on. The POR has a falling threshold of 2.4V typically. At power on, all counters are reset to zero.

Charge Current and R_{IREF} Selection

When the ISL6292B is used as a traditional linear charger, the R_{IREF} sets the constant charge current. The trickle charge current is 10% of the CC current I_{REF} . When working with a current-limited supply, the CC current is determined by the supply limited current I_{LIM} . I_{REF} needs to be programmed higher than I_{LIM} and is used as an overcurrent protection. Taking into account the tolerance of both the I_{LIM} and I_{REF} , it is recommended the I_{REF} be programmed at least 30% higher than the I_{LIM} . I_{REF} can be found by the following equation:

$$I_{REF} = \frac{0.8V}{R_{IREF}} \times 10^5 (A) \quad (EQ. 1)$$

The trickle charge current is 10% of I_{REF} , that is,

$$I_{Trickle} = \frac{0.8V}{R_{IREF}} \times 10^4 (A) \quad (EQ. 2)$$

The ISL6292B has a comparator with 100mV offset voltage to ensure the input voltage is higher than the battery voltage before charging starts (see the Block Diagram). This condition requires I_{LIM} be higher than 400mA. The upper limit for I_{LIM} is 1.5A.

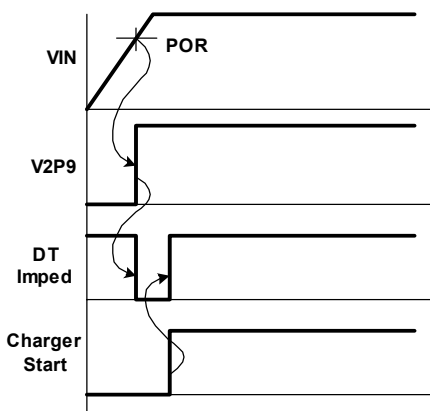

FIGURE 3. EVENT SEQUENCE AT POWER UP

EOC Current and R_{IMIN} Selection

The EOC current is programmed by the IMIN pin and can be calculated by the following equation:

$$I_{MIN} = \frac{0.8V}{R_{IMIN}} \times 10^4 (A) \quad (EQ. 3)$$

The EOC current has a programming range up to 400mA.

To qualify as an EOC condition, the charge current needs to drop below the I_{MIN} level and stay below the I_{MIN} level for more than three to four cycles of the internal oscillator; additionally, the battery voltage rises above the recharge threshold given in the Electrical Specification table.

Internal Oscillator

The internal oscillator establishes a timing reference. The oscillation period is programmable with an external timing capacitor, C_{TIME} , as shown in Typical Applications. The oscillator charges the timing capacitor to 1.5V and then discharges it to 0.5V in one period, both with 10 μ A current. The period T_{OSC} is:

$$T_{OSC} = 0.2 \cdot 10^6 \cdot C_{TIME} \quad (\text{seconds}) \quad (EQ. 4)$$

A 1nF capacitor results in a 0.2ms oscillation period. The accuracy of the period is mainly dependent on the accuracy of the capacitance and the internal current source.

Total Charge Time and C_{TIME} Selection

The total charge time for the CC mode and CV mode is limited to a length of TIMEOUT, which can be found by:

$$\text{TIMEOUT} = 14 \cdot \frac{C_{TIME}}{1nF} \quad (\text{minutes}) \quad (EQ. 5)$$

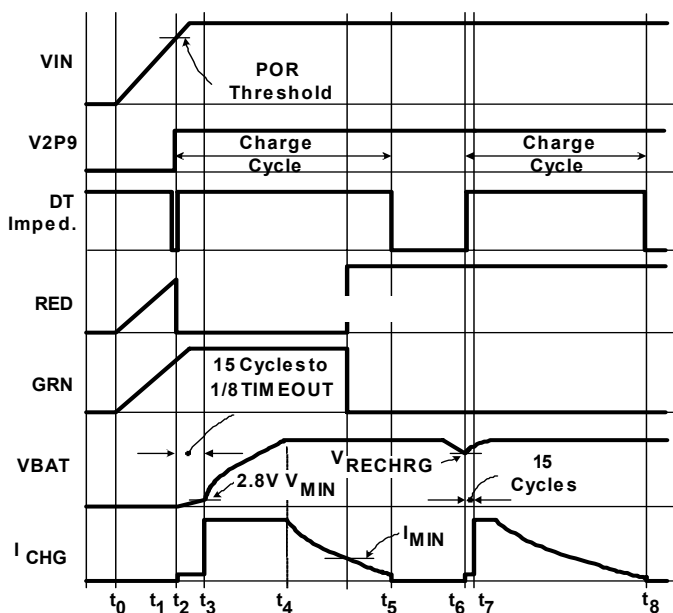

FIGURE 4. OPERATION WAVEFORMS

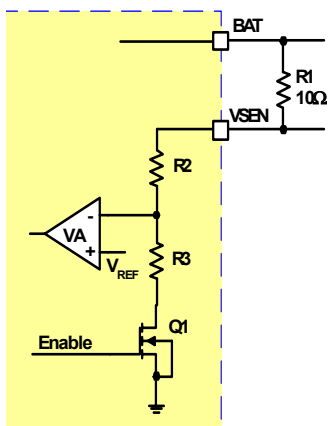

FIGURE 5. THE INTERNAL VOLTAGE FEEDBACK CIRCUIT

C_{TIME} is the timing capacitor shown in the Typical Application circuit. A 1nF capacitor leads to 14 minutes of TIMEOUT. For example, a 15nF capacitor sets the TIMEOUT to be 3.5 hours. The charger is terminated when the TIMEOUT is reached.

The trickle mode charge has a time limit of $1/8$ TIMEOUT. If the battery voltage does not reach V_{MIN} within that limit, a TIMEOUT fault is issued and the charger latches up. The charger stays in trickle mode for at least 15 cycles of the internal oscillator and, at most, $1/8$ of TIMEOUT.

Recharge Threshold

The charger terminates when the TIMEOUT limit expires. After the termination, if the battery is below the recharge threshold given in the Electrical Specification table, the charger starts a re-charge cycle.

LED Indications

RED and GRN are two open-drain outputs that directly drive a tri-color LED. At the moment when the power is applied or when the charger is enabled through the EN pin, the charger starts to charge and the RED indication pin outputs a low impedance to drive a red LED. Once the charge finishes (either when the EOC condition is qualified or when the TIMEOUT completes), the GRN pin turns on to drive a green LED and the red LED is off. The green LED remains on unless the input power is recycled, or when the EN pin is toggled, or a fault case happens. When a recharge occurs, the indication remains in green.

When a fault case happens, both the RED and the GRN pins are on to indicate a yellow color. If the FAULT is a TIMEOUT fault, the yellow indication is latched and can only be reset through the EN pin or the input power. If the FAULT is an ambient temperature FAULT, the charger restarts after the fault condition is removed. When not powered or when not enabled, both LEDs are off. Table 1 summarizes the LED indications.

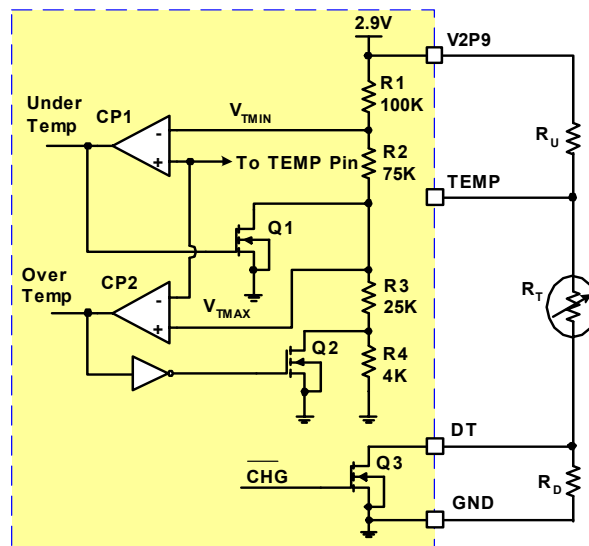

FIGURE 6. THE INTERNAL AND EXTERNAL CIRCUIT FOR THE NTC INTERFACE

TABLE 1. LED INDICATION SUMMARY

STATUS	RED	GRN	INDICATION
Charging	L	H	Red
Full Charge (EOC), or recharging	H	L	Green
Trickle TIMEOUT Error	L	L	Yellow (Latched)
Over/Under Ambient Temperature	L	L	Yellow
No Battery	H	H	Off

VSEN Pin

The VSEN pin allows remote sensing of the battery voltage to minimize the resistive voltage drop between the charger output and the battery positive terminal. Figure 5 shows the internal voltage feedback circuit. In applications that the remote sense pin goes through a connector, a local low-value resistor is recommended, as the R_1 shown in Figure 5, in case the connector has bad contact. The sum of R_2 and R_3 is 75k Ω , therefore, a 10 Ω R_1 is negligible in output voltage accuracy.

Ambient Temperature Sensing

The TEMP pin is used to set the ambient temperature range that allows charging the battery. Typically, an NTC (negative temperature coefficient) resistor is mounted on the printed circuit board (PCB) to monitor the ambient temperature. Due to the self-heating of the PCB during charging, the ISL6292B provides the DT pin to set a higher temperature threshold after the charger starts.

Figure 6 shows the internal circuit for the ambient temperature sensing function. The two comparators form a window comparator whose high-threshold is V_{TMIN} and low-threshold is V_{TMAX} . These two thresholds are given in the Electrical Specifications. The two MOSFETs (Q1 and Q2)

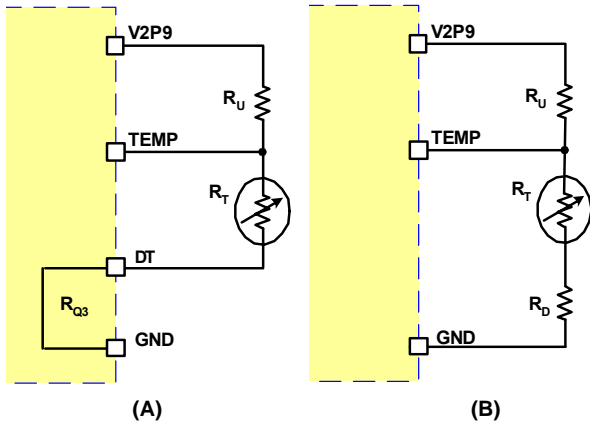

FIGURE 7. EQUIVALENT CIRCUITS FOR THE NTC DIVIDER
(A) BEFORE CHARGING STARTS
(B) DURING CHARGING.

create a hysteresis for each comparator respectively. The DT pin is shorted to GND via the internal Q3 MOSFET when the charger is not charging, resulting in the equivalent circuit shown in Figure 7 (A). The on-resistance of Q3 is typically 50Ω and is negligible compared to the external resistors. When the charger starts to charge, Q3 is turned off to set a higher temperature range determined by the external resistor R_D. The equivalent circuit is shown in Figure 7 (B). The DT pin allows the user to set up a higher shut down ambient temperature after the charger starts up.

The selection of R_U and R_T uses the same procedure described in the ISL6292 datasheet. The selection R_D follows the following equation:

$$R_D = R_{T,@45^\circ\text{C}} - R_{T,@(45^\circ\text{C} + \Delta T)}$$

where R_{T,@45°C} is the thermistor resistance at 45°C and the R_{T,@(45°C + ΔT)} is the resistance at 45°C + ΔT. Figure 8 shows the temperature windows before, during, and after charging. Before and after charging, the temperature window is -5°C to 45°C with 5°C hysteresis. During charging, the high temperature limit changes to 45°C + ΔT. If this limit is exceeded, the charger is stopped and the temperature has to come back to below 40°C for the charging to be allowed again. The low temperature limit is also increased. However, the R_D typically has a much lower resistance than the NTC at low temperature, therefore, the influence on the temperature threshold is not as much as at high temperature. Typically, the low temperature threshold is raised by less than 2°C, as shown in Figure 8.

Charge Current Thermal Foldback

The thermal foldback function monitors the die temperature and reduces the charge current when the die temperature rises above 100°C to prevent further temperature rise. The charge current reduces at a rate of 100mA/°C after exceeding 100°C. For a charger with the constant charge current set at 1A, the charge current is reduced to zero when

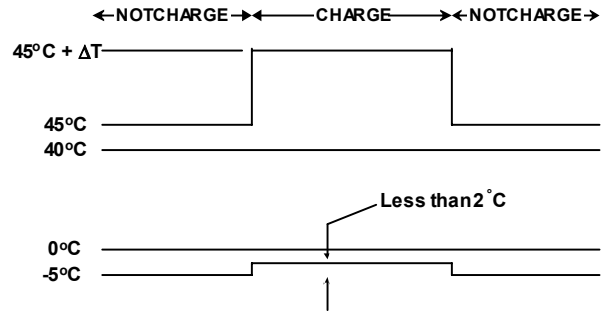

FIGURE 8. BOARD TEMPERATURE MONITORING WHEN THE CHARGE IS NOT CHARGING, THE TEMPERATURE WINDOW IS -5°C AND 45°C. ONCE THE CHARGER STARTS, THE TEMPERATURE WINDOW IS 1.X°C TO 45°C + ΔT.

the internal temperature rises to 110°C. The actual charge current settles between 100°C to 110°C.

Usually the charge current should not drop below I_{MIN} because of the thermal foldback. For some extreme cases if that does happen, the charger does not indicate end-of-charge unless the battery voltage is already above the recharge threshold.

2.9V Bias Voltage

The ISL6292B provides a 2.9V voltage for biasing the internal control and logic circuit. This voltage is also available for external circuits such as the NTC thermistor circuit. The maximum allowed external load is 2mA.

EN Pin

The EN pin allows direct interface to the battery ID pin of a battery pack. The battery ID pin is connected with a resistor of a value less than 27kΩ to ground inside the battery pack. When the battery is not attached, the EN pin is pulled up by an internal source to the V2P9 pin to disable the charger. The 2.9V internal regulator is on as long as the input power is applied, independent of the EN input. Table 2 summarizes the status of each pin when the IC is disabled.

TABLE 2. SUMMARY OF PIN BEHAVIOR WHEN THE IC IS DISABLED BY THE EN PIN

PIN	BEHAVIOR
V2P9	Outputs 2.9V.
RED	High impedance
GRN	High impedance
DT	Low impedance
IREF	Outputs 0.8V
IMIN	Outputs 0.8V
TEMP	The temperature monitoring circuit remains functioning.

Board Layout Recommendations

The ISL6292B is targeted for space-limited applications. In order to maximize the current capability, it is very important that the exposed pad under the package is properly soldered to the board and is connected to other layers through thermal vias. More thermal vias and more copper attached to the exposed pad usually result in better thermal performance. On the other hand, the number of vias is limited by the size of the pad. The exposed pads for the 4x4 QFN package are able to have 5 vias. As much copper as possible should be connected to the exposed pad to minimize the thermal impedance. Refer to the ISL6292B evaluation board for layout examples.

**Quad Flat No-Lead Plastic Package (QFN)
Micro Lead Frame Plastic Package (MLFP)**

L16.4x4

16 LEAD QUAD FLAT NO-LEAD PLASTIC PACKAGE
(COMPLIANT TO JEDEC MO-220-VGGC ISSUE C)

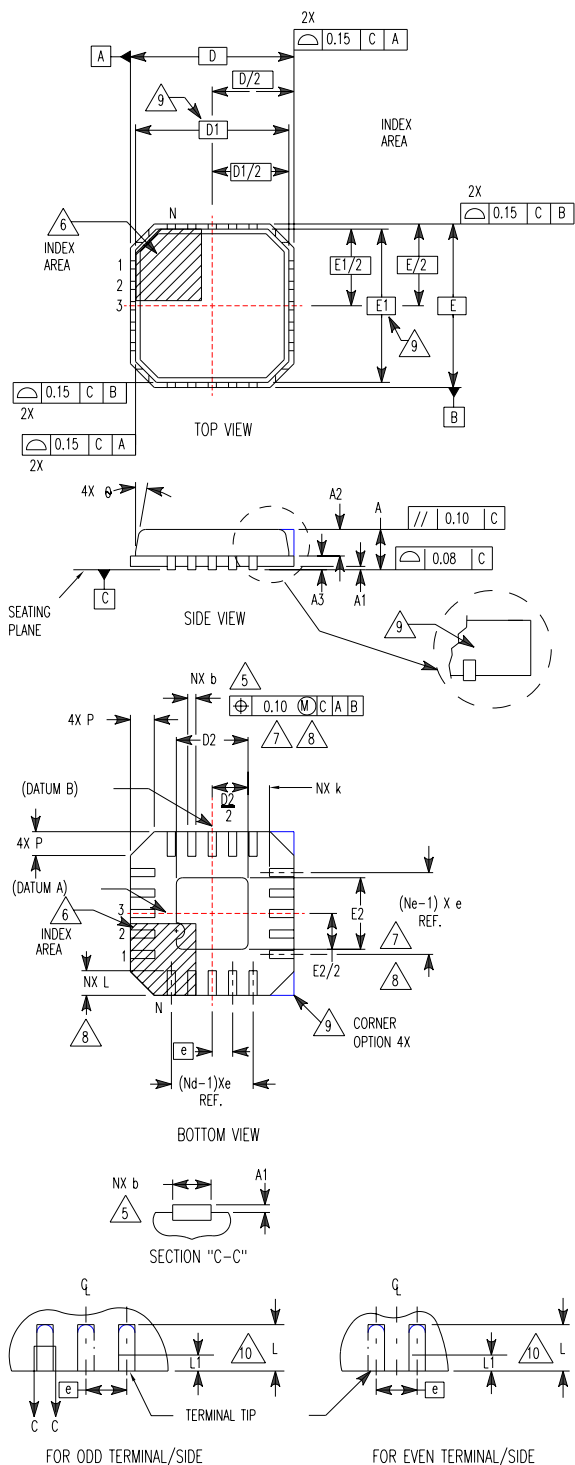

SYMBOL	MILLIMETERS			NOTES
	MIN	NOMINAL	MAX	
A	0.80	0.90	1.00	-
A1	-	-	0.05	-
A2	-	-	1.00	9
A3	0.20 REF			9
b	0.23	0.28	0.35	5, 8
D	4.00 BSC			-
D1	3.75 BSC			9
D2	1.95	2.10	2.25	7, 8
E	4.00 BSC			-
E1	3.75 BSC			9
E2	1.95	2.10	2.25	7, 8
e	0.65 BSC			-
k	0.25	-	-	-
L	0.50	0.60	0.75	8
L1	-	-	0.15	10
N	16			2
Nd	4			3
Ne	4			3
P	-	-	0.60	9
θ	-	-	12	9

Rev. 5 5/04

NOTES:

1. Dimensioning and tolerancing conform to ASME Y14.5-1994.
2. N is the number of terminals.
3. Nd and Ne refer to the number of terminals on each D and E.
4. All dimensions are in millimeters. Angles are in degrees.
5. Dimension b applies to the metallized terminal and is measured between 0.15mm and 0.30mm from the terminal tip.
6. The configuration of the pin #1 identifier is optional, but must be located within the zone indicated. The pin #1 identifier may be either a mold or mark feature.
7. Dimensions D2 and E2 are for the exposed pads which provide improved electrical and thermal performance.
8. Nominal dimensions are provided to assist with PCB Land Pattern Design efforts, see Intersil Technical Brief TB389.
9. Features and dimensions A2, A3, D1, E1, P & θ are present when Anvil singulation method is used and not present for saw singulation.
10. Depending on the method of lead termination at the edge of the package, a maximum 0.15mm pull back (L1) maybe present. L minus L1 to be equal to or greater than 0.3mm.

All Intersil U.S. products are manufactured, assembled and tested utilizing ISO9000 quality systems.
Intersil Corporation's quality certifications can be viewed at www.intersil.com/design/quality

Intersil products are sold by description only. Intersil Corporation reserves the right to make changes in circuit design, software and/or specifications at any time without notice. Accordingly, the reader is cautioned to verify that data sheets are current before placing orders. Information furnished by Intersil is believed to be accurate and reliable. However, no responsibility is assumed by Intersil or its subsidiaries for its use; nor for any infringements of patents or other rights of third parties which may result from its use. No license is granted by implication or otherwise under any patent or patent rights of Intersil or its subsidiaries.

For information regarding Intersil Corporation and its products, see www.intersil.com