

## White LED Boost Regulator With Integrated Schottky Diode

The ISL97631 represents a high efficiency, constant frequency PWM regulator with integrated boost diode and FET. Designed for use in white LED driving applications, the ISL97631 features efficiencies up to 85%. It operates at 1.35MHz switching frequency and operates from an input voltage of between 2.7V and 5.5V. The maximum output voltage of 27V enables the ISL97631 to drive up to 6 LEDs in series. It is also possible to use the ISL97631 to drive LEDs in series/parallel combination for applications requiring up to 15 LEDs.

Available in the 6 Ld TSOT package, the ISL97631 offers high efficiency, constant frequency operation. It is specified for operation over the -40°C to +85°C ambient temperature range.

### Pinout

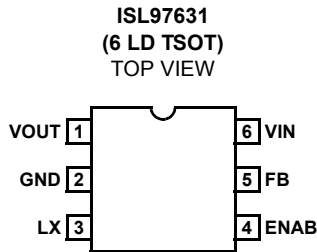

### Features

- Up to 6 LEDs in series
- 27V maximum output
- 2.7V to 5.5V input
- Up to 85% efficient
- 1.35MHz constant frequency
- Enable/PWM dimming control
- Pb-free plus anneal available (RoHS compliant)

### Applications

- LED backlighting
- Cell phones
- PDAs
- Handheld games
- MP3 players
- GPS
- Other handheld devices

### Ordering Information

PART NUMBER	PART MARKING	PCS.	TAPE & REEL	PACKAGE (TAPE AND REEL)	PKG. DWG. #
ISL97631IHTZ-T7 (See Note)	631Z	3,000	7"	6 Ld TSOT (Pb-free)	MDP0049
ISL97631IHTZ-T7A (See Note)	631Z	270	7"	6 Ld TSOT (Pb-free)	MDP0049

NOTE: Intersil Pb-free plus anneal products employ special Pb-free material sets; molding compounds/die attach materials and 100% matte tin plate termination finish, which are RoHS compliant and compatible with both SnPb and Pb-free soldering operations. Intersil Pb-free products are MSL classified at Pb-free peak reflow temperatures that meet or exceed the Pb-free requirements of IPC/JEDEC J STD-020.

# ISL97631

## Absolute Maximum Ratings (T<sub>A</sub> = 25°C)

Input Voltage (V <sub>IN</sub> )	-0.3V to +6V
LX, Vout Voltage	-0.3V to +27V
FB Voltage	-0.3V to +6V
ENAB Voltage	-0.3V to +6V
Operating Temperature	-40°C to +85°C

## Thermal Information

Thermal Resistance (Typical, Note 1)	θ <sub>JA</sub> (°C/W)
6 Ld TSOT	190
Maximum Junction Temperature (Plastic Package)	150°C
Maximum Storage Temperature Range	-65°C to +150°C
Maximum Lead Temperature (Soldering, 10s)	+300°C (TSOT - Lead Tips Only)

**CAUTION:** Stresses above those listed in "Absolute Maximum Ratings" may cause permanent damage to the device. This is a stress only rating and operation of the device at these or any other conditions above those indicated in the operational sections of this specification is not implied.

**IMPORTANT NOTE:** All parameters having Min/Max specifications are guaranteed over the specified temperature range. All parameters are based on pulsed tests, therefore: T<sub>J</sub> = T<sub>C</sub> = T<sub>A</sub>

### NOTE:

1. θ<sub>JA</sub> is measured with the component mounted on a high effective thermal conductivity test board in free air. See Tech Brief TB379 for details.

## Electrical Specifications V<sub>IN</sub> = 3V, V<sub>ENAB</sub> = 3V, T<sub>A</sub> = -40°C to 85°C unless otherwise specified.

PARAMETER	DESCRIPTION	CONDITION	MIN	TYP	MAX	UNIT
V <sub>IN-MIN</sub>	Minimum Operating Voltage	V <sub>OUT</sub> = 16V, I <sub>LED</sub> = 20mA	2.7			V
V <sub>IN-MAX</sub>	Maximum Operating Voltage	V <sub>OUT</sub> = 25V, I <sub>LED</sub> = 20mA			5.5	V
V <sub>FB</sub>	Feedback Voltage		80	100	120	mV
I <sub>FB</sub>	FB Pin Bias Current				100	nA
I <sub>IN</sub>	Supply Current	ENAB = 3V, output not switching		0.6	1.0	mA
		ENAB = 0V			1	µA
F <sub>OSC</sub>	Switching Frequency		0.8	1.35	1.8	MHz
D <sub>MAX</sub>	Maximum Duty Cycle	T <sub>A</sub> = 25°C	85	90		%
			82	90		%
I <sub>LIM</sub>	Switch Current Limit	T <sub>A</sub> = 25°C	280	350		mA
			250	350		mA
r <sub>DS(ON)</sub>	Switch On Resistance	I <sub>LX</sub> = 100mA		750		mΩ
I <sub>LEAK(LX)</sub>	Switch Leakage Current	V <sub>LX</sub> = 27V, V <sub>out</sub> = 27V		0.01	1	µA
I <sub>LEAK(VOUT)</sub>	Diode Leakage Current	V <sub>OUT</sub> = 27V		0.01	1	µA
V <sub>DIODE</sub>	LX-V <sub>OUT</sub> Diode Forward Voltage	I <sub>DIODE</sub> = 100mA, T <sub>A</sub> = 25°C		0.75	0.9	V
V <sub>ENAB-HI</sub>	ENAB Voltage High		2.5			V
V <sub>ENAB-LO</sub>	ENAB Voltage Low				0.6	V
I <sub>ENAB</sub>	ENAB Pin Bias Current				1	µA
ΔI <sub>LED</sub> /ΔV <sub>IN</sub>	Line Regulation	V <sub>IN</sub> = 2.7V to 5V		0.2		%/V
Eff	Efficiency	I <sub>LED</sub> = 20mA, 3 LEDs		85		%

Typical Application

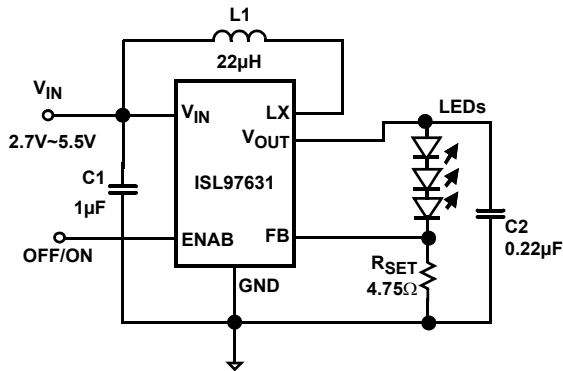

FIGURE 1. TYPICAL APPLICATION CIRCUIT

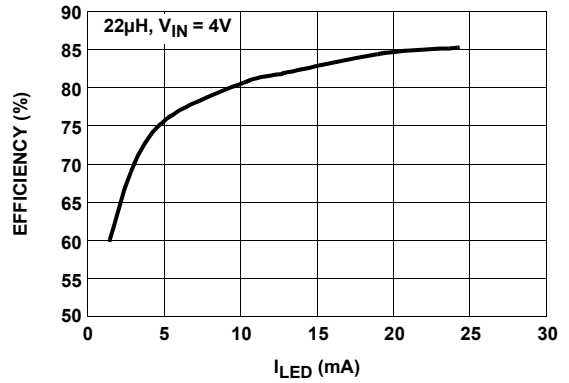

FIGURE 2. EFFICIENCY vs LED CURRENT ( $V_{IN} = 4V$ )

Typical Performance Curves

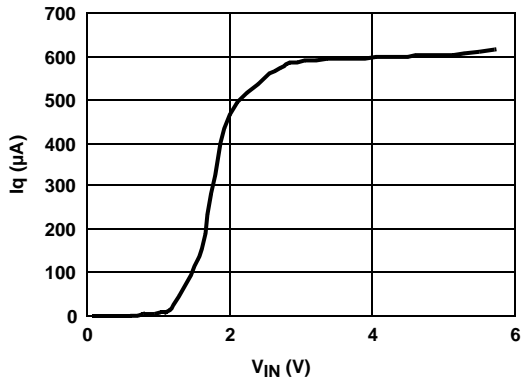

FIGURE 3. QUIESCENT CURRENT vs  $V_{IN}$  (ENAB = hi)

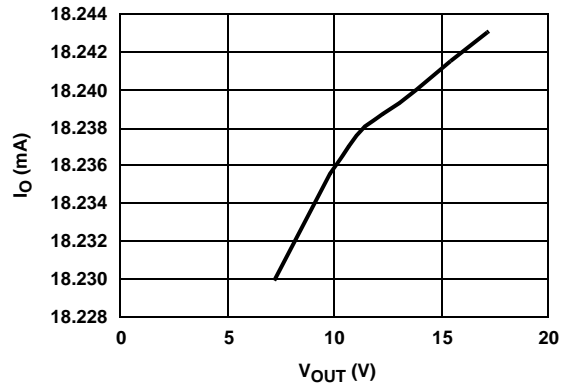

FIGURE 4. LOAD REGULATION ( $V_{IN} = 4V$ )

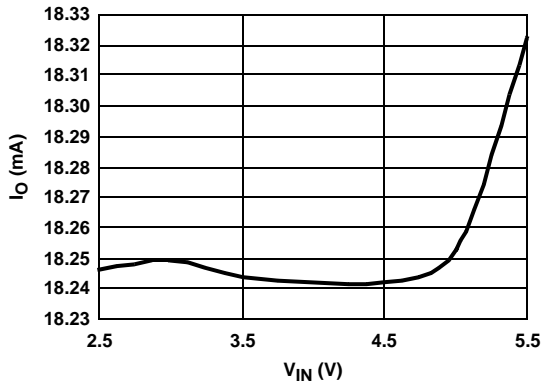

FIGURE 5. LINE REGULATION

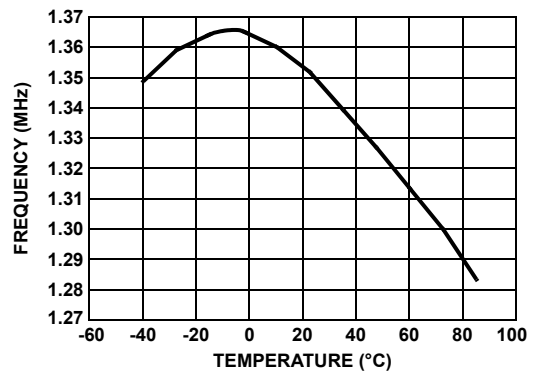

FIGURE 6. SWITCHING FREQUENCY vs TEMPERATURE

**Block Diagram**

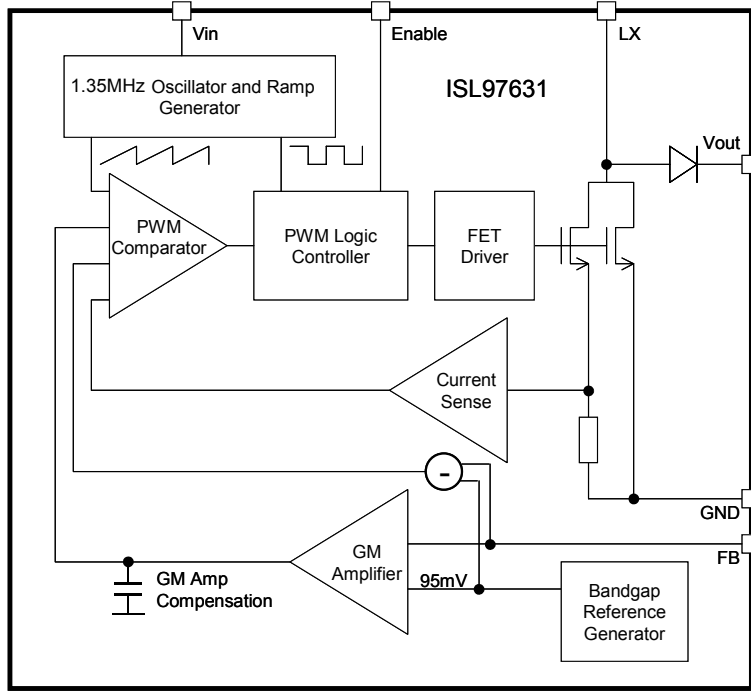

FIGURE 7. ISL97631 BLOCK DIAGRAM

**Pin Descriptions**

PIN NUMBER	PIN NAME	DESCRIPTION
1	VOUT	Output Pin. Connect to the anode of the top LED and the output filter capacitor .
2	GND	Ground Pin. Connect to local ground.
3	LX	Switching Pin. Connect to inductor.
4	ENAB	Enable Pin. Connect to enable signal to turn-on or off the device.
5	FB	Feedback Pin. Connect to the cathode of bottom LED and the sense resistor.
6	VIN	Input Supply Pin. Connect to the input supply voltage, the inductor and the input supply decoupling capacitor.

**Detailed Description**

The ISL97631 uses a constant frequency, current mode control scheme to provide excellent line and load regulation. It can drive up to 6 LEDs in series or 15 LEDs in parallel/series configuration, with efficiencies of up to 85%. The ISL97631 operates from an input voltage of 2.7V to 5.5V and can boost up to 27V.

**Steady-State Operation**

The ISL97631 operates with constant frequency PWM. The switching frequency is around 1.35MHz. Depending on the input voltage, inductance, number of LEDs and the LED

current, the converter operates in either continuous conduction mode or discontinuous conduction mode. Both are normal. The forward current of the LED is set using the  $R_{SET}$  resistor. In steady state mode, this current is given by the equation:

$$I_{LED} = \frac{V_{FB}}{R_{SET}} \quad (EQ. 1)$$

**Shut-Down**

When taken low the ENAB pin places the ISL97631 into power down mode. When in power down, the supply current is reduced to less than 1µA.

**Dimming Control**

**PWM DIMMING**

The ENAB pin also doubles as a brightness control. There are two different possible dimming control methods. The first dimming method is controlled through the duty-cycle of the ENAB input PWM waveform, which can operate at frequencies up to 1kHz. For frequencies greater than 1kHz, see Analog Dimming. The LEDs operate at either zero or full current. This is the PWM dimming control method. The relationship between the average LED current and the duty-cycle (D) of the ENAB pin's waveform is as follows:

$$\text{average } I_{LED} = \frac{V_{FB}}{R_{SET}} \cdot D \quad (EQ. 2)$$

The magnitude of the PWM signal should be higher than the minimum ENAB voltage high. The bench PWM dimming test results are shown in Figure 8. In the test, two PWM frequencies 400Hz and 1kHz are chosen to compare the linear dimming range. It is clear that there is a wider linear dimming range for the lower PWM frequency than for the higher one, due to the self discharge of the output capacitor through the LEDs during the low ENAB periods. To achieve a better linearity with high frequencies an NMOS FET can be placed between the FB pin and the LED stack, with its gate driven by the same signal as ENAB. This acts to prevent self discharge of the output capacitor during the off periods. In the PWM dimming test, the output capacitor is 0.22μF.

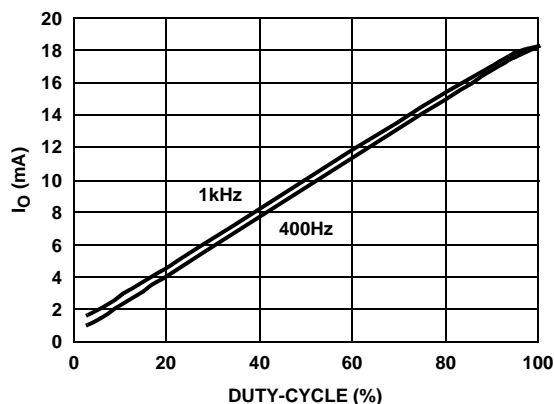

FIGURE 8. PWM DIMMING LINEAR RANGE (FOR 400Hz AND 1kHz PWM FREQUENCIES CONDITION, C<sub>OUT</sub> = 0.22μF)

### ANALOG DIMMING

The second dimming method applies a variable DC voltage (V<sub>Dim</sub>) at FB pin (see Figure 9) to adjust the LED current. As the DC dimming signal voltage increases above V<sub>FB</sub>, the voltages drop on R<sub>1</sub> and R<sub>2</sub> increase and the voltage drop on R<sub>SET</sub> decreases. Thus, the LED current decreases.

$$I_{LED} = \frac{V_{FB} \cdot (R_1 + R_2) - V_{Dim} \cdot R_1}{R_2 \cdot R_{SET}} \quad (EQ. 3)$$

The DC dimming signal voltage can be a variable DC voltage or a DC voltage generated by filtering a high frequency PWM control signal.

As brightness is directly proportional to LED currents, V<sub>Dim</sub> may be calculated for any desired “relative brightness” (F) using Equation 4.

$$V_{Dim} = \frac{R_2}{R_1} \cdot V_{FB} \cdot \left( 1 + \frac{R_1}{R_2} - F \right) \quad (EQ. 4)$$

Where F = I<sub>LED</sub> (dimmed)/I<sub>LED</sub> (undimmed).

These equations are valid for values of R1 and R2 such that both R1 >> R<sub>SET</sub> and R2 >> R<sub>SET</sub>.

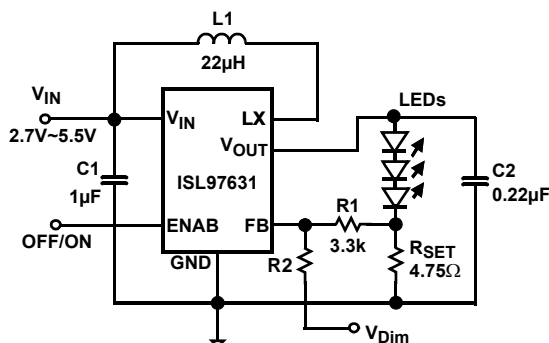

FIGURE 9. ANALOG DIMMING CONTROL APPLICATION CIRCUIT

The analog dimming circuit can be tailored to a desired relative brightness for different V<sub>Dim</sub> ranges using Equation 5.

$$R_2 = \frac{[(V_{Dim\_max} - V_{FB}) \cdot R_1]}{[V_{FB} \cdot (1 - F_{min})]} \quad (EQ. 5)$$

Where V<sub>Dim\_max</sub> is the maximum V<sub>Dim</sub> voltage and F<sub>min</sub> is the minimum relative brightness (i.e., the brightness with V<sub>Dim\_max</sub> applied).

i.e., V<sub>Dim\_max</sub> = 5V, F<sub>min</sub> = 10% (i.e., 0.1), R<sub>2</sub> = 189k

i.e., V<sub>Dim\_max</sub> = 1V, F<sub>min</sub> = 10% (i.e., 0.1), R<sub>2</sub> = 35k

### Open-Voltage Protection

In some applications, it is possible that the output is opened, e.g. when the LEDs are disconnected from the circuit or the LEDs fail. In this case the feedback voltage will be zero. The ISL97631 will then switch to a high duty cycle resulting in a high output voltage, which may cause the LX pin voltage to exceed its maximum 27V rating. To implement overvoltage protection, a zener diode Dz and a resistor R<sub>1</sub> can be used at the output and FB pin to limit the voltage on the LX pin as shown in Figure 10. It is clear that as the zener is turned on, due to the overvoltage, the zener diode’s current will set up a voltage on R<sub>1</sub> and R<sub>SET</sub> and this voltage is applied on FB pin as the feedback node. This feedback will prevent the output from reaching the overvoltage condition. In the overvoltage protection circuit design, the zener voltage should be larger than the maximum forward voltage of the LED string.

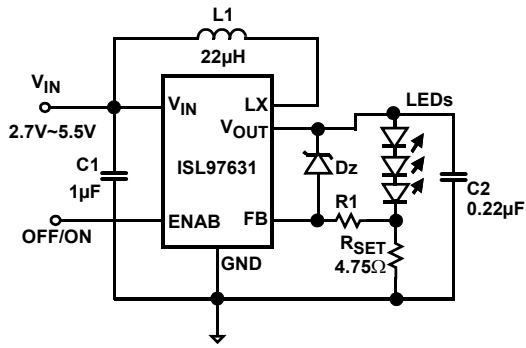

FIGURE 10. LED DRIVER WITH OVERVOLTAGE PROTECTION CIRCUIT

**Components Selection**

The input capacitance is typically 0.22µF. The output capacitor should be in the range of 0.22µF to 1µF. X5R or X7R type of ceramic capacitors of the appropriate voltage rating are recommended. The output capacitor value affects PWM dimming performance. Lower output capacitor values increase the range of PWM dimming. However, the ripple voltage will be greater for lower values.

When choosing an inductor, make sure the average and peak current ratings are adequate by using the following formulas (80% efficiency assumed):

$$I_{LAVG} = \frac{I_{LED} \cdot V_{OUT}}{0.8 \cdot V_{IN}} \tag{EQ. 6}$$

$$I_{LPK} = I_{LAVG} + \frac{1}{2} \cdot \Delta I_L \tag{EQ. 7}$$

$$\Delta I_L = \frac{V_{IN} \cdot (V_{OUT} - V_{IN})}{L \cdot V_{OUT} \cdot f_{OSC}} \tag{EQ. 8}$$

Where:

- $\Delta I_L$  is the peak-to-peak inductor current ripple in Amps
- L is the inductance in H.
- $f_{OSC}$  is the switching frequency, typically 1.35MHz

The ISL97631 supports a wide range of inductance values (22µH~82µH). For lower inductor values or lighter loads, the boost inductor current may become discontinuous. For high boost inductor values, the boost inductor current will be in continuous mode.

The demo board efficiency bench test results are shown in Figure 11. The input voltage is 4V and curves are shown for 2, 3, 4, 5 and 6 LEDs (boost inductor L = 22µH).

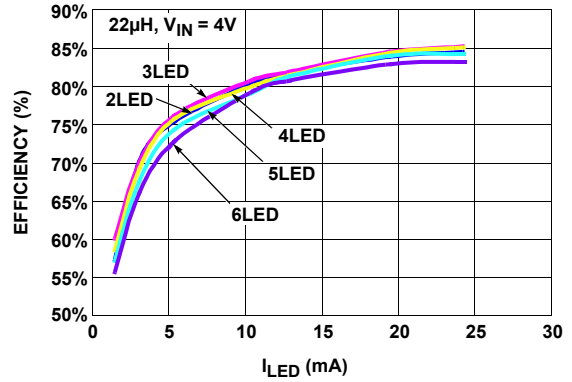

FIGURE 11. EFFICIENCY CURVE WITH 2, 3, 4, 5 AND 6 LEDs LOAD

**White LED Connections**

One leg of LEDs connected in series will ensure brightness uniformity. The 27V maximum output voltage specification enables up to 6 LEDs to be placed in series.

In order to drive more LEDs, series/parallel connections are used. A current mirror circuit (as shown in Figure 12) should be used to balance LED currents.

Parallel strings of LEDs may draw significantly different currents due to manufacturing and temperature differences. For correct operation of the current mirror circuit, the total voltage between FB pin and the top of the primary LED string must be equal to or greater than the other strings. To ensure this, a small value resistor may be inserted between FB pin and the primary LED string.

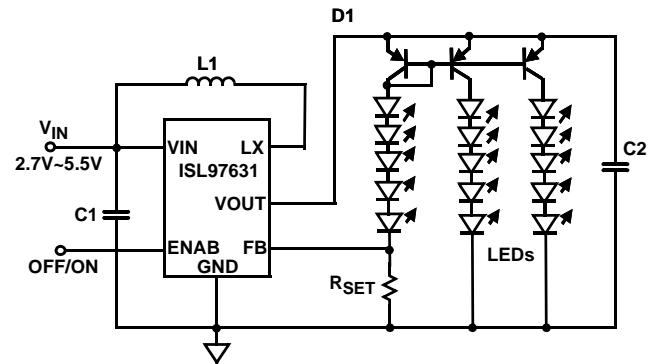

FIGURE 12. LEDs IN SERIES/PARALLEL WITH MIRROR CURRENT BALANCE

## **PCB Layout Considerations**

The layout is very important for the converter to function properly.  $R_{SET}$  must be located as close as possible to the FB and GND pins. Longer traces to the LEDs are OK. Similarly, the supply decoupling cap and the output filter cap should be as close as possible to the  $V_{IN}$  and  $V_{OUT}$  pins.

The heat of the IC is mainly dissipated through the GND pin. Maximizing the copper area connected to this pin is preferable. In addition, a solid ground plane is always helpful for the EMI performance.

The demo board is a good example of layout based on the principle. Please refer to the ISL97631 Application Brief for the layout.

Package Outline

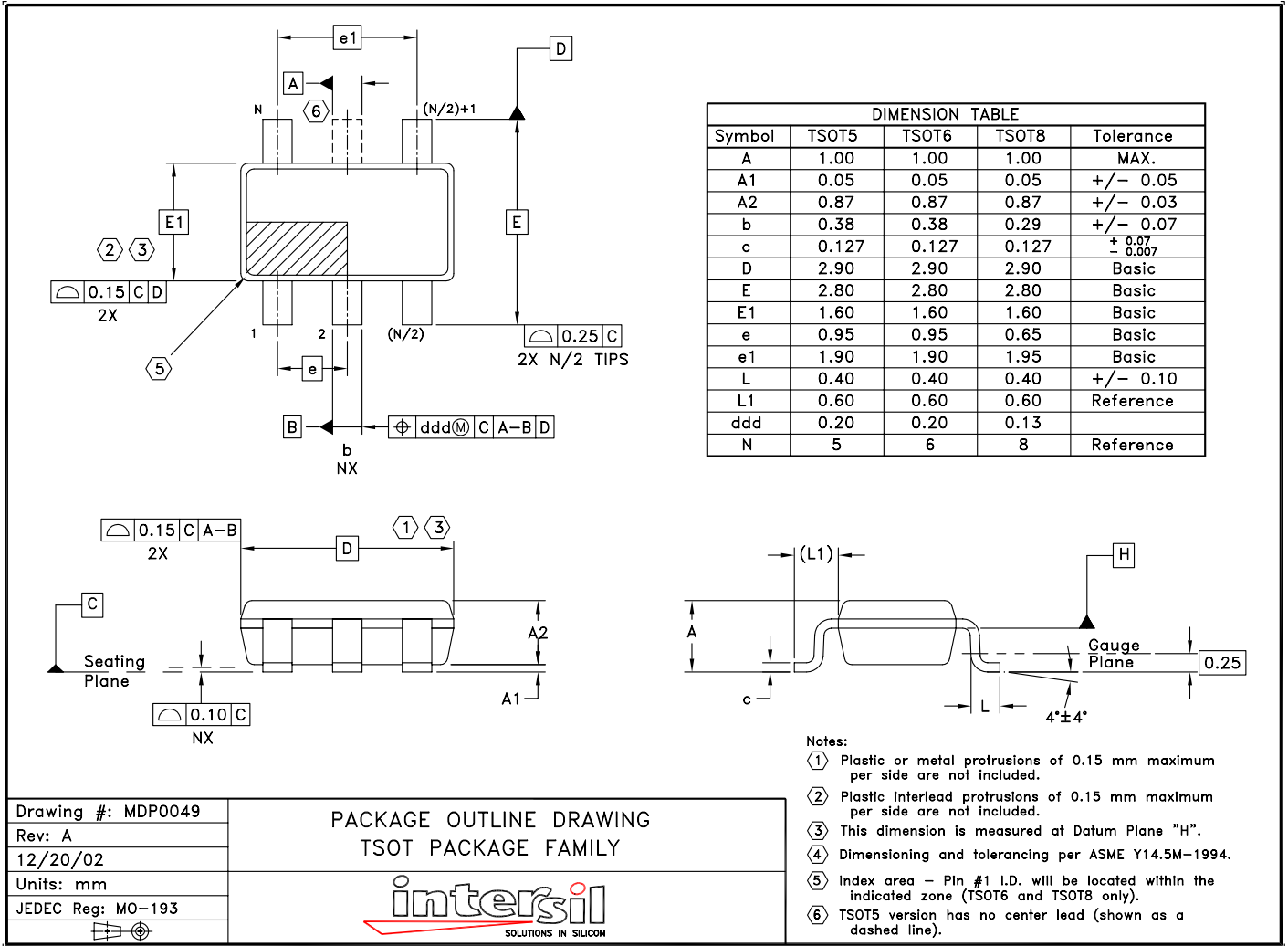

Drawing #: MDP0049  
 Rev: A  
 12/20/02  
 Units: mm  
 JEDEC Reg: MO-193

PACKAGE OUTLINE DRAWING  
 TSOT PACKAGE FAMILY



- Notes:
- ① Plastic or metal protrusions of 0.15 mm maximum per side are not included.
  - ② Plastic interlead protrusions of 0.15 mm maximum per side are not included.
  - ③ This dimension is measured at Datum Plane "H".
  - ④ Dimensioning and tolerancing per ASME Y14.5M-1994.
  - ⑤ Index area - Pin #1 I.D. will be located within the indicated zone (TSOT6 and TSOT8 only).
  - ⑥ TSOT5 version has no center lead (shown as a dashed line).

All Intersil U.S. products are manufactured, assembled and tested utilizing ISO9000 quality systems. Intersil Corporation's quality certifications can be viewed at [www.intersil.com/design/quality](http://www.intersil.com/design/quality)

Intersil products are sold by description only. Intersil Corporation reserves the right to make changes in circuit design, software and/or specifications at any time without notice. Accordingly, the reader is cautioned to verify that data sheets are current before placing orders. Information furnished by Intersil is believed to be accurate and reliable. However, no responsibility is assumed by Intersil or its subsidiaries for its use; nor for any infringements of patents or other rights of third parties which may result from its use. No license is granted by implication or otherwise under any patent or patent rights of Intersil or its subsidiaries.

For information regarding Intersil Corporation and its products, see [www.intersil.com](http://www.intersil.com)