

# 1A Ultra Low Dropout Linear Regulator with Programmable Current Limiting

## ISL80121-5

The ISL80121-5 is a low dropout voltage, single output LDO with programmable current limiting. The ISL80121-5 operates from input voltages of 5V to 6V with a nominal output voltage of 5V. Other custom voltage options are available upon request.

A sub-micron BiCMOS process is utilized for this product family to deliver the best in class analog performance and overall value. The programmable current limiting improves system reliability of end applications. An external capacitor on the soft-start pin provides an adjustable soft-starting ramp. The ENABLE feature allows the part to be placed into a low quiescent current shutdown mode.

This BiCMOS LDO will consume significantly lower quiescent current as a function of load compared to bipolar LDOs, which translates into higher efficiency and packages with smaller footprints. Quiescent current is modestly compromised to achieve a very fast load transient response.

TABLE 1. KEY DIFFERENCES BETWEEN FAMILY OF PARTS

| PART NUMBER  | PROGRAMMABLE I <sub>LIMIT</sub> | I <sub>LIMIT</sub> (DEFAULT) | ADJ or FIXED V <sub>OUT</sub> |
|--------------|---------------------------------|------------------------------|-------------------------------|
| ISL80101-ADJ | No                              | 1.75A                        | ADJ                           |
| ISL80101     | No                              | 1.75A                        | 1.8V, 2.5V, 3.3V, 5.0V        |
| ISL80101A    | Yes                             | 1.62A                        | ADJ                           |
| ISL80121-5   | Yes                             | 0.75A                        | 5.0V                          |

## Features

- ±1.8% V<sub>OUT</sub> Accuracy Guaranteed Over Line, Load and T<sub>J</sub> = -40 °C to +125 °C
- Very Low 130mV Dropout Voltage at V<sub>IN</sub> = 5.0V
- High Accuracy Current Limit Programmable up to 1.75A
- Very Fast Transient Response
- 210µV<sub>RMS</sub> Output Noise
- Power-Good Output
- Programmable Soft-Start
- Over-Temperature Protection
- Small 10 Ld DFN Package

## Applications

- USB devices
- Telecommunications and Networking
- Medical Equipment
- Instrumentation Systems
- Routers and Switchers
- Gaming

## Typical Applications

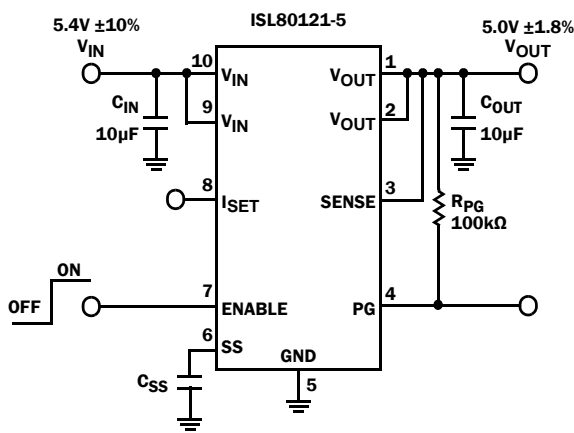

$$I_{LIMIT} = 0.75A$$

(DEFAULT)

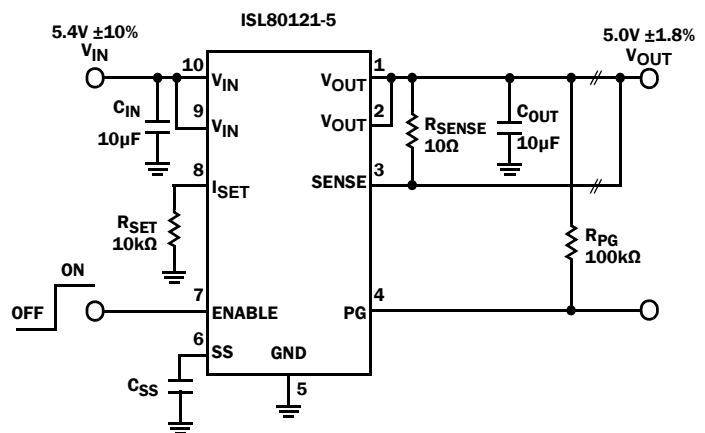

$$I_{LIMIT} = 0.75 + \frac{2.9}{R_{SET}(k\Omega)}$$

## Block Diagram

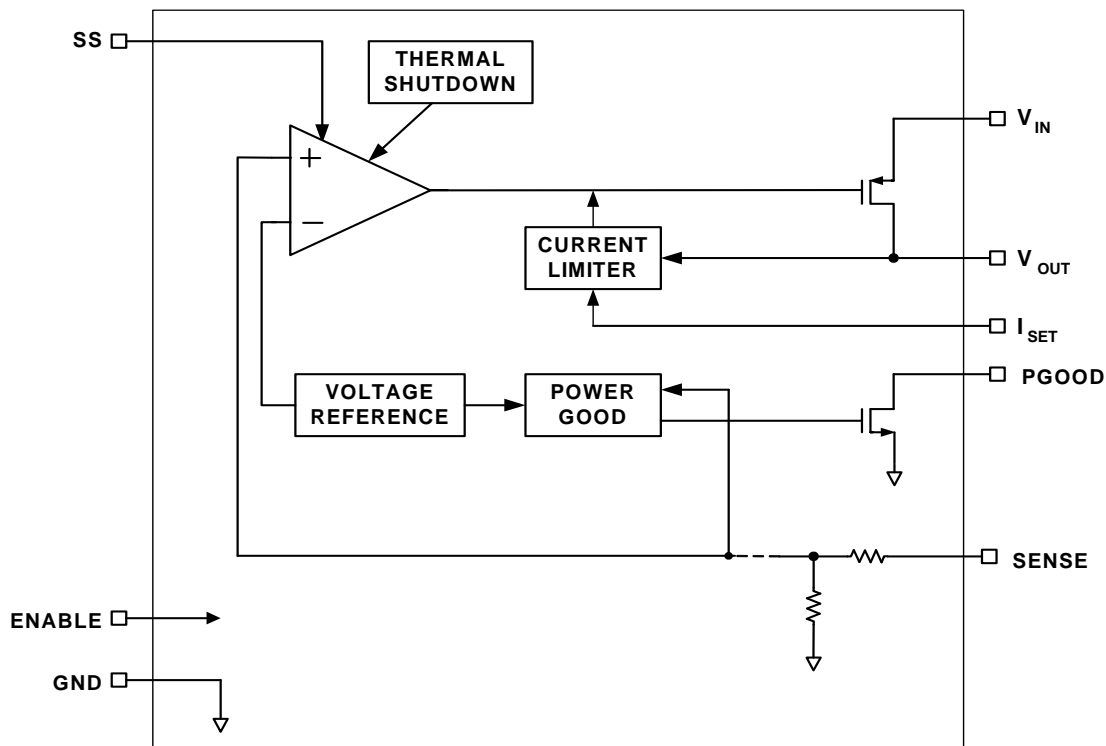

## Ordering Information

| PART NUMBER<br>(Notes 1, 2, 3) | PART<br>MARKING  | V <sub>OUT</sub> VOLTAGE | TEMP. RANGE<br>(°C) | PACKAGE<br>(Pb-Free) | PKG<br>DWG. # |
|--------------------------------|------------------|--------------------------|---------------------|----------------------|---------------|
| ISL80121IR50Z                  | DZAD             | 5.0V                     | -40 to +125         | 10 Ld 3x3 DFN        | L10.3x3       |
| ISL80121-5EVAL2Z               | Evaluation Board |                          |                     |                      |               |

### NOTES:

1. Add "-T\*" suffix for tape and reel. Please refer to [TB347](#) for details on reel specifications.
2. These Intersil Pb-free plastic packaged products employ special Pb-free material sets, molding compounds/die attach materials, and 100% matte tin plate plus anneal (e3 termination finish, which is RoHS compliant and compatible with both SnPb and Pb-free soldering operations). Intersil Pb-free products are MSL classified at Pb-free peak reflow temperatures that meet or exceed the Pb-free requirements of IPC/JEDEC J STD-020.
3. For Moisture Sensitivity Level (MSL), please see device information page for [ISL80121-5](#). For more information on MSL, please see Technical Brief [TB363](#).

# ISL80121-5

## Pin Configuration

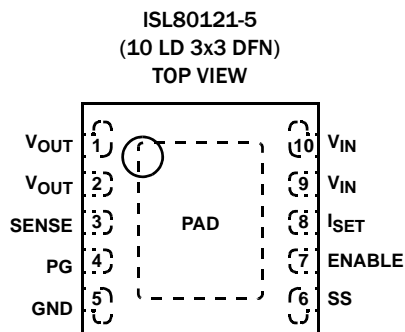

## Pin Descriptions

| PIN NUMBER | PIN NAME         | DESCRIPTION   |
|------------|------------------|---|
| 1, 2       | V <sub>OUT</sub> | Output voltage. A minimum 10μF X5R/X7R output capacitor is required for stability. See “External Capacitor Requirements” on page 8 in the “Functional Description” for more details.  |
| 3          | SENSE            | Remote voltage sense for internally fixed V <sub>OUT</sub> options. Parasitic resistance between the V <sub>OUT</sub> pin and the load causes small voltage drops which degrade V <sub>OUT</sub> accuracy. For applications that require a stiff V <sub>OUT</sub> , connect the sense pin to the load.  |
| 4          | PG               | V <sub>OUT</sub> in regulation signal. Logic low indicates V <sub>OUT</sub> is not in regulation, and must be grounded if not used.   |
| 5          | GND              | Ground.   |
| 6          | SS               | External capacitor adjusts in-rush current.   |
| 7          | ENABLE           | V <sub>IN</sub> -independent chip enable. TTL and CMOS compatible.  |
| 8          | I <sub>SET</sub> | Current limit setting. Current limit is 0.75A when this pin is left floating. This default value can be increased by tying R <sub>SET</sub> to GND, or decreased by tying R <sub>SET</sub> to V <sub>IN</sub> . See “Programmable Current Limit” on page 7 in the “Functional Description” for more details. Do not short this pin to ground. |
| 9, 10      | V <sub>IN</sub>  | Input supply. A minimum of 10μF X5R/X7R input capacitor is required for stability. See “External Capacitor Requirements” on page 8 in “Functional Description” for more details.  |
| -          | EPAD             | EPAD at ground potential. Soldering it directly to GND plane is required for thermal considerations. See “Power Dissipation and Thermals” on page 9 for more details.   |

# ISL80121-5

## Absolute Maximum Ratings (Note 6)

|   |                           |
|---|---------------------------|
| $V_{IN}$ Relative to GND                  | -0.3V to +6.5V            |
| $V_{OUT}$ Relative to GND                 | -0.3V to +6.5V            |
| PG, ENABLE, SENSE, SS, $I_{SET}$          |                           |
| Relative to GND                           | -0.3V to +6.5V            |
| ESD Rating                                |                           |
| Human Body Model (Tested per JESD22-A114) | 2.5kV                     |
| Machine Model (Tested per JESD22-A115)    | 250V                      |
| Latch Up (Tested per JESD78)              | $\pm 100\text{mA}$ @ 85°C |

## Thermal Information

|  |   |                      |
|--|---|----------------------|
| Thermal Resistance (Typical)                   | $\theta_{JA}$ (°C/W)  | $\theta_{JC}$ (°C/W) |
| 10 Ld 3x3 DFN Package (Notes 4, 5)             | 48  | 7                    |
| Maximum Junction Temperature (Plastic Package) | +150°C  |                      |
| Storage Temperature Range                      | -65°C to +150°C   |                      |
| Pb-Free Reflow Profile                         | see link below  |                      |
|  | <a href="http://www.intersil.com/pbfree/Pb-FreeReflow.asp">http://www.intersil.com/pbfree/Pb-FreeReflow.asp</a> |                      |

## Recommended Operating Conditions (Note 7)

|                                      |                     |
|--------------------------------------|---------------------|
| Junction Temperature Range ( $T_J$ ) | -40°C to +125°C     |
| $V_{IN}$ Relative to GND             | 5V to 6V            |
| $I_{SET}$ in Normal Operation        | $\leq 500\text{mV}$ |
| SENSE in Normal Operation            | $V_{OUT}$           |
| PG Sink Current                      | 10mA                |

**CAUTION:** Do not operate at or near the maximum ratings listed for extended periods of time. Exposure to such conditions may adversely impact product reliability and result in failures not covered by warranty.

### NOTES:

- $\theta_{JA}$  is measured in free air with the component mounted on a high effective thermal conductivity test board with “direct attach” features. See Tech Brief [TB379](#).
- For  $\theta_{JC}$ , the “case temp” location is the center of the exposed metal pad on the package underside.
- Absolute maximum voltage rating is defined as the voltage applied for a lifetime average duty cycle above 6V of 1%.
- Electromigration specification defined as lifetime average junction temperature of +110°C where max rated DC current = lifetime average current.

## Electrical Specifications

Unless otherwise noted, all parameters are established over the following specified conditions:

$V_{IN} = V_{OUT} + 0.4\text{V}$ ,  $V_{OUT} = 5.0\text{V}$ ,  $C_{IN} = C_{OUT} = 10\mu\text{F}$ ,  $T_J = +25^\circ\text{C}$ ,  $I_{LOAD} = 0\text{A}$ . Applications must follow thermal guidelines of the package to determine worst case junction temperature. Please refer to “Functional Description” on page 7 and Tech Brief [TB379](#).

**Boldface limits apply over the operating temperature range, -40°C to +125°C.** Pulse load techniques used by ATE to ensure  $T_J = T_A$  defines established limits.

| PARAMETER                                      | SYMBOL                         | TEST CONDITIONS   | MIN (Note 8) | TYP  | MAX (Note 8) | UNITS         |
|--|--------------------------------|---|--------------|------|--------------|---------------|
| <b>DC CHARACTERISTICS</b>                      |                                |   |              |      |              |               |
| DC Output Voltage Accuracy                     | $V_{OUT}$                      | $V_{OUT} + 0.4\text{V} < V_{IN} < 6\text{V}$ ; $0\text{A} < I_{LOAD} < 1\text{A}$                         | <b>-1.8</b>  |      | <b>1.8</b>   | %             |
| DC Input Line Regulation                       | $\Delta V_{OUT}/\Delta V_{IN}$ | $V_{OUT} + 0.4\text{V} < V_{IN} < 6.0\text{V}$ , $V_{OUT} = 5.0\text{V}$                                  |              |      | <b>1</b>     | %             |
| DC Output Load Regulation                      | $\Delta V_{OUT}$               | $0\text{A} < I_{LOAD} < 1\text{A}$  | <b>-1</b>    |      |              | %             |
| Ground Pin Current                             | $I_Q$                          | $I_{LOAD} = 0\text{A}$ , $2.2\text{V} < V_{IN} < 6\text{V}$   |              | 3    | <b>5</b>     | mA            |
|  |                                | $I_{LOAD} = 1\text{A}$ , $2.2\text{V} < V_{IN} < 6\text{V}$   |              | 5    | <b>7</b>     | mA            |
| Ground Pin Current in Shutdown                 | $I_{SHDN}$                     | ENABLE = 0.2V, $V_{IN} = 6\text{V}$   |              | 0.2  | <b>12</b>    | $\mu\text{A}$ |
| Dropout Voltage (Note 9)                       | $V_{DO}$                       | $I_{LOAD} = 1\text{A}$ , $V_{IN} = 5.0\text{V}$ , $V_{SENSE} = 0\text{V}$                                 |              | 90   | <b>130</b>   | mV            |
| Output Current Limit                           | $I_{LIMIT}$                    | $V_{OUT} = 4.75\text{V}$ , $V_{OUT} + 0.4\text{V} < V_{IN} < 6\text{V}$ , $I_{SET}$ is floating           | <b>0.66</b>  | 0.75 | <b>0.84</b>  | A             |
|  |                                | $V_{OUT} = 4.75\text{V}$ , $V_{OUT} + 0.4\text{V} < V_{IN} < 6\text{V}$ , $R_{SET} = 19.33\text{k}\Omega$ |              | 0.9  |              | A             |
| Thermal Shutdown Temperature                   | TSD                            | $V_{OUT} + 0.4\text{V} < V_{IN} < 6\text{V}$  |              | 160  |              | °C            |
| Thermal Shutdown Hysteresis (Rising Threshold) | TSDn                           | $V_{OUT} + 0.4\text{V} < V_{IN} < 6\text{V}$  |              | 30   |              | °C            |
| <b>AC CHARACTERISTICS</b>                      |                                |   |              |      |              |               |
| Input Supply Ripple Rejection                  | PSRR                           | $f = 1\text{kHz}$ , $I_{LOAD} = 1\text{A}$  |              | 40   |              | dB            |
|  |                                | $f = 1\text{kHz}$ , $I_{LOAD} = 100\text{mA}$   |              | 40   |              | dB            |

# ISL80121-5

## Electrical Specifications

Unless otherwise noted, all parameters are established over the following specified conditions:  $V_{IN} = V_{OUT} + 0.4V$ ,  $V_{OUT} = 5.0V$ ,  $C_{IN} = C_{OUT} = 10\mu F$ ,  $T_J = +25^\circ C$ ,  $I_{LOAD} = 0A$ . Applications must follow thermal guidelines of the package to determine worst case junction temperature. Please refer to "Functional Description" on page 7 and Tech Brief [TB379](#).

**Boldface limits apply over the operating temperature range,  $-40^\circ C$  to  $+125^\circ C$ .** Pulse load techniques used by ATE to ensure  $T_J = T_A$  defines established limits. (Continued)

| PARAMETER                         | SYMBOL         | TEST CONDITIONS                              | MIN<br>(Note 8) | TYP  | MAX<br>(Note 8) | UNITS         |
|-----------------------------------|----------------|--|-----------------|------|-----------------|---------------|
| Output Noise Voltage              |                | $I_{LOAD} = 10mA$ , $BW = 10Hz < f < 100kHz$ |                 | 210  |                 | $\mu V_{RMS}$ |
| <b>ENABLE PIN CHARACTERISTICS</b> |                |  |                 |      |                 |               |
| Turn-on Threshold                 | $V_{EN(HIGH)}$ | $2.2V < V_{IN} < 6V$                         | <b>0.3</b>      | 0.8  | <b>1.0</b>      | V             |
| Hysteresis (Rising Threshold)     | $V_{EN(HYS)}$  | $2.2V < V_{IN} < 6V$                         | <b>10</b>       | 80   | <b>200</b>      | mV            |
| ENABLE Pin Turn-on Delay          | $t_{EN}$       | $C_{OUT} = 10\mu F$ , $I_{LOAD} = 1A$        |                 | 100  |                 | $\mu s$       |
| ENABLE Pin Leakage Current        |                | $V_{IN} = 6V$ , $ENABLE = 3V$                |                 |      | <b>1</b>        | $\mu A$       |
| <b>SOFT-START CHARACTERISTICS</b> |                |  |                 |      |                 |               |
| Reset Pull-Down Current           | $I_{PD}$       | $ENABLE = 0V$ , $SS = 1V$                    | <b>0.5</b>      | 1    | <b>1.3</b>      | mA            |
| Soft-Start Charge Current         | $I_{CHG}$      |  | <b>-3.3</b>     | -2   | <b>-0.8</b>     | $\mu A$       |
| <b>PG PIN CHARACTERISTICS</b>     |                |  |                 |      |                 |               |
| $V_{OUT}$ PG Flag Threshold       |                |  | <b>75</b>       | 84   | <b>92</b>       | $\%V_{OUT}$   |
| $V_{OUT}$ PG Flag Hysteresis      |                |  |                 | 4    |                 | %             |
| PG Flag Low Voltage               |                | $I_{SINK} = 500\mu A$                        |                 | 47   | <b>100</b>      | mV            |
| PG Flag Leakage Current           |                | $V_{IN} = 6V$ , $PG = 6V$                    |                 | 0.05 | <b>1</b>        | $\mu A$       |

### NOTES:

- Compliance to data sheet limits is assured by one or more methods: production test, characterization and/or design.
- Dropout is defined by the difference in supply  $V_{IN}$  and  $V_{OUT}$  when the output is below its nominal regulation.

## Typical Operating Performance

$T_J = +25^\circ\text{C}$ ,  $I_L = 0\text{A}$ .

Unless otherwise noted:  $V_{IN} = 5.4\text{V}$ ,  $V_{OUT} = 5.0\text{V}$ ,  $C_{IN} = C_{OUT} = 10\mu\text{F}$ ,

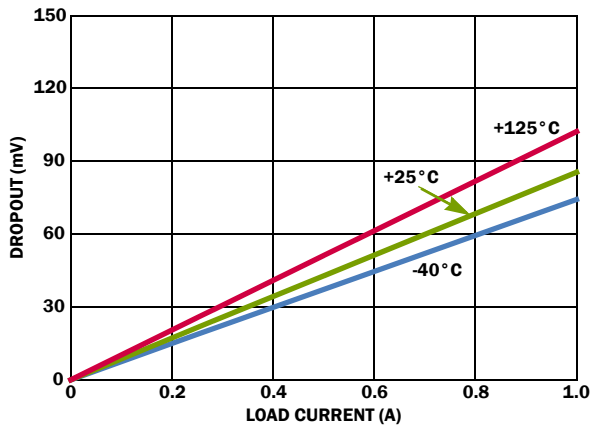

FIGURE 1. DROPOUT VOLTAGE vs LOAD

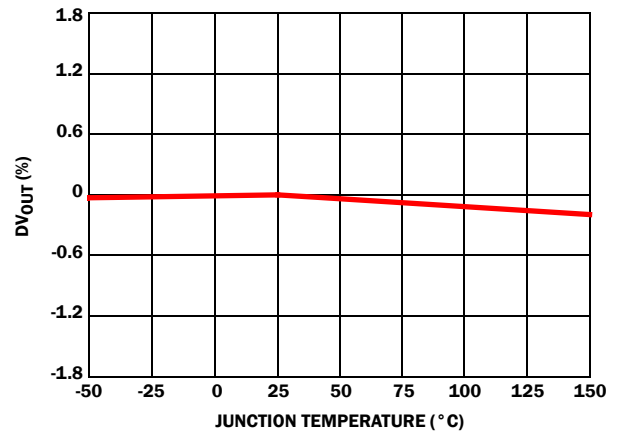

FIGURE 2. OUTPUT VOLTAGE vs TEMPERATURE

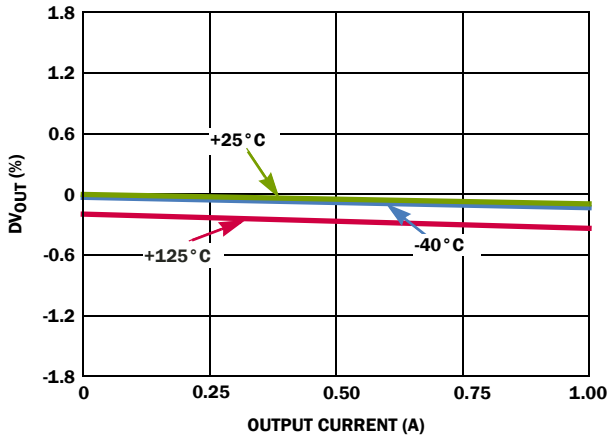

FIGURE 3. OUTPUT VOLTAGE vs OUTPUT CURRENT

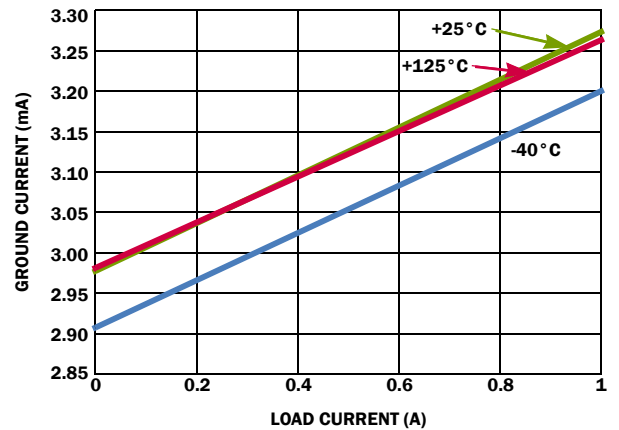

FIGURE 4. GROUND CURRENT vs LOAD CURRENT

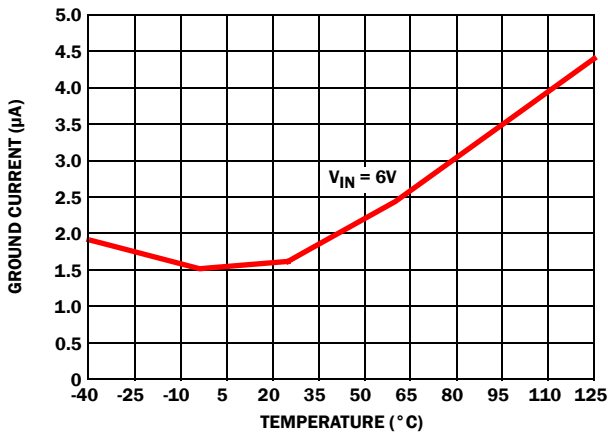

FIGURE 5. SHUTDOWN CURRENT vs TEMPERATURE

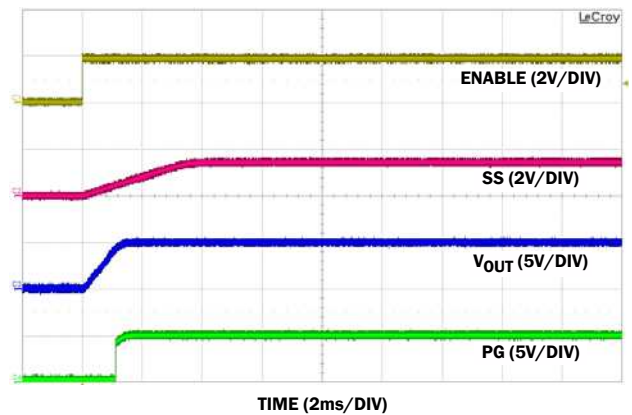

FIGURE 6. ENABLE START-UP

## Typical Operating Performance

$T_J = +25^\circ\text{C}$ ,  $I_L = 0\text{A}$ . (Continued)

Unless otherwise noted:  $V_{IN} = 5.4\text{V}$ ,  $V_{OUT} = 5.0\text{V}$ ,  $C_{IN} = C_{OUT} = 10\mu\text{F}$ ,

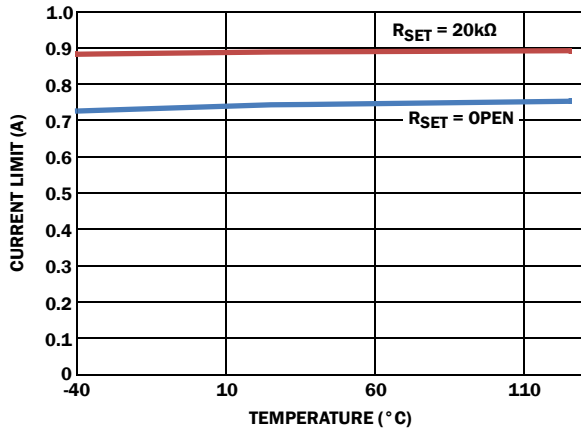

FIGURE 7. CURRENT LIMIT vs TEMPERATURE

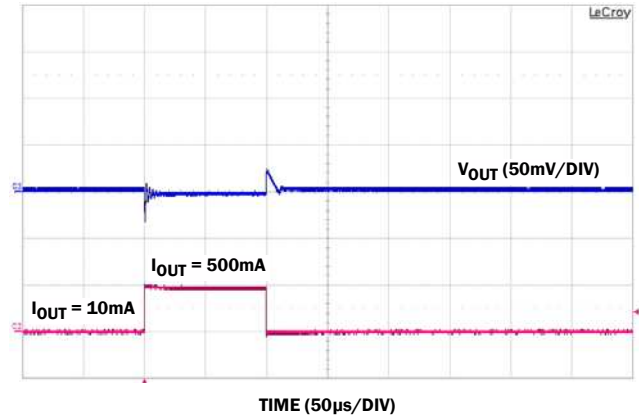

FIGURE 8. LOAD TRANSIENT RESPONSE

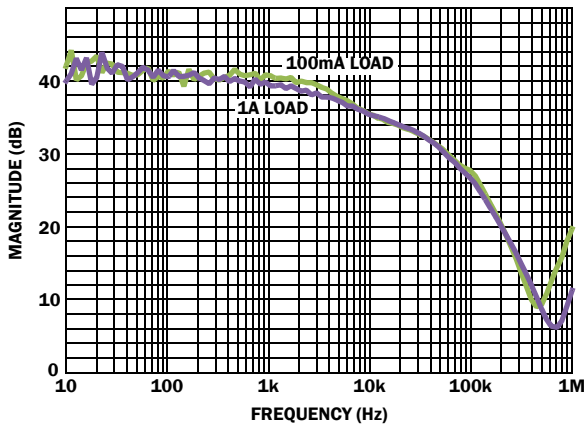

FIGURE 9. PSRR vs LOAD

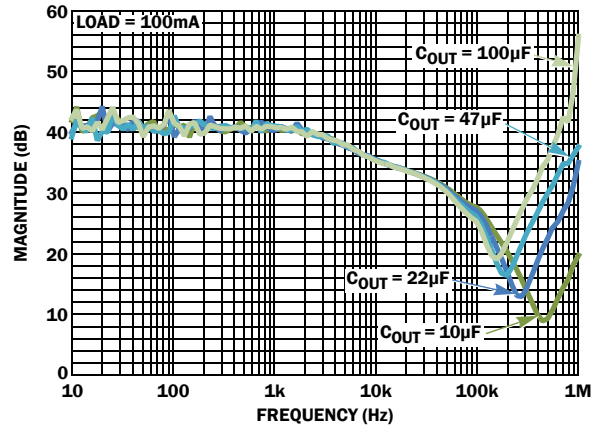

FIGURE 10. PSRR vs  $C_{OUT}$

## Functional Description

### Input Voltage Requirements

The ISL80121-5 is optimized for 5V output, and can operate from input voltages of 5V to 6V. Due to the nature of an LDO,  $V_{IN}$  must be some margin higher than  $V_{OUT}$  plus dropout at the maximum rated current of the application if active filtering (PSRR) is expected from  $V_{IN}$  to  $V_{OUT}$ . The generous dropout specification of this family of LDOs allows applications to design for a level of efficiency that can accommodate profiles smaller than the TO220/263.

### Programmable Current Limit

The ISL80121-5 protects against overcurrent due to short-circuit and overload conditions applied to the output. When this happens, the LDO performs as a constant current source. If the short-circuit or overload condition is removed, the output returns to normal voltage regulation operation.

The current limit is set at 0.75A by default when the  $I_{SET}$  pin is left floating.

This limit can be increased by tying a resistor  $R_{SET}$  from the  $I_{SET}$  pin to ground. The current limit is determined by  $R_{SET}$  as shown in Equation 1:

$$I_{LIMIT} = 0.75 + \frac{2.9}{R_{SET}(k\Omega)} \quad (\text{EQ. 1})$$

Figure 11 shows the relationship between  $R_{SET}$  and the current limit when the  $R_{SET}$  is tied from  $I_{SET}$  pin to GND. Do not short this pin to ground. Increasing the current limit past 1.75A may cause damage to the part and is highly discouraged.

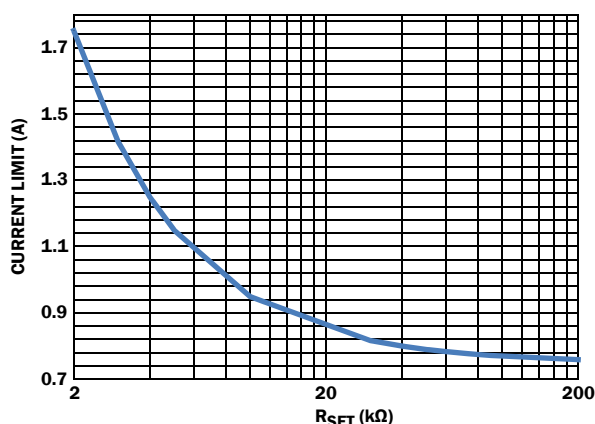

FIGURE 11. INCREASING I<sub>LIMIT</sub> (R<sub>SET</sub> TO GND)

The current limit can be decreased from the 0.75A default by tying R<sub>SET</sub> from the I<sub>SET</sub> pin to V<sub>IN</sub>. The current limit is then determined by both R<sub>SET</sub> and V<sub>IN</sub> following Equation 2:

$$I_{LIMIT} = 0.75 - \frac{2.9 \times (2 \times V_{IN} - 1)}{R_{SET}(k\Omega)} \quad (\text{EQ. 2})$$

Figure 12 shows the relationship between R<sub>SET</sub> and the current limit when R<sub>SET</sub> is tied from the I<sub>SET</sub> pin to V<sub>IN</sub> for V<sub>IN</sub> = 5.4V.

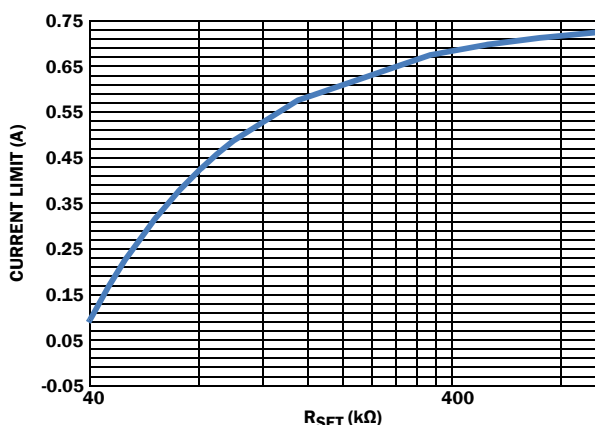

FIGURE 12. DECREASING I<sub>SET</sub> (R<sub>SET</sub> TO V<sub>IN</sub>)

## Enable Operation

The ENABLE turn-on threshold is typically 800mV with 80mV of hysteresis. An internal pull-up or pull-down resistor to change these values is available upon request. As a result, this pin must not be left floating, and should be tied to V<sub>IN</sub> if not used. A 1kΩ to 10kΩ pull-up resistor is required for applications that use open collector or open drain outputs to control the ENABLE pin. The ENABLE pin may be connected directly to V<sub>IN</sub> for applications with outputs that are always on.

## Power-Good Operation

PG is a logic output that indicates the status of V<sub>OUT</sub>, current limit tripping, and V<sub>IN</sub>. The PG flag is an open-drain NMOS that can sink up to 10mA during a fault condition. The PG pin requires an external pull-up resistor typically connected to the V<sub>OUT</sub> pin. The PG pin should not be pulled up to a voltage source greater than

V<sub>IN</sub>. PG goes low when the output voltage drops below 84% of the nominal output voltage, the current limit faults, or the input voltage is too low. PG functions during shutdown, but not during thermal shutdown. For applications not using this feature, connect this pin to ground.

## Soft-Start Operation

The soft-start circuit controls the rate at which the output voltage rises up to regulation at power-up or LDO enable. This start-up ramp time can be set by adding an external capacitor from the SS pin to ground. An internal 2μA current source charges up this C<sub>SS</sub> and the feedback reference voltage is clamped to the voltage across it. The start-up time is set by Equation 3:

$$t_{start} = \frac{(C_{SS} \times 0.5)}{2\mu A} \quad (\text{EQ. 3})$$

Equation 4 determines the C<sub>SS</sub> required for a specific start-up in-rush current, where V<sub>OUT</sub> is the output voltage, C<sub>OUT</sub> is the total capacitance on the output and I<sub>INRUSH</sub> is the desired in-rush current.

$$C_{SS} = \frac{(V_{OUT} \times C_{OUT} \times 2\mu A)}{I_{INRUSH} \times 0.5V} \quad (\text{EQ. 4})$$

The external capacitor is always discharged to ground at the beginning of start-up or enabling.

## External Capacitor Requirements

External capacitors are required for proper operation. Careful attention must be paid to the layout guidelines and selection of capacitor type and value to ensure optimal performance.

## OUTPUT CAPACITOR

The ISL80121-5 applies state-of-the-art internal compensation to keep the selection of the output capacitor simple for the customer. Stable operation over full temperature, V<sub>IN</sub> range, V<sub>OUT</sub> range and load extremes are guaranteed for all capacitor types and values assuming a minimum of 10μF X5R/X7R is used for local bypass on V<sub>OUT</sub>. This output capacitor must be connected to the V<sub>OUT</sub> and GND pins of the LDO with PCB traces no longer than 0.5cm.

There is a growing trend to use very-low ESR multilayer ceramic capacitors (MLCC) because they can support fast load transients and also bypass very high frequency noise from other sources. However, the effective capacitance of MLCCs drops with applied voltage, age, and temperature. X7R and X5R dielectric ceramic capacitors are strongly recommended as they typically maintain a capacitance range within ±20% of nominal voltage over full operating ratings of temperature and voltage.

Additional capacitors of any value in ceramic, POSCAP, alum/tantalum electrolytic types may be placed in parallel to improve PSRR at higher frequencies and/or load transient AC output voltage tolerances.

## INPUT CAPACITOR

For proper operation, a minimum capacitance of 10μF X5R/X7R is required at the input. This ceramic input capacitor must be connected to the V<sub>IN</sub> and GND pins of the LDO with PCB traces no longer than 0.5cm.



## Power Dissipation and Thermals

The junction temperature must not exceed the range specified in the “Recommended Operating Conditions (Note 7)” on page 4. The power dissipation can be calculated by using Equation 5:

$$P_D = (V_{IN} - V_{OUT}) \times I_{OUT} + V_{IN} \times I_{GND} \quad (\text{EQ. 5})$$

The maximum allowable junction temperature,  $T_{J(\text{MAX})}$  and the maximum expected ambient temperature,  $T_{A(\text{MAX})}$  determine the maximum allowable power dissipation, as shown in Equation 6:

$$P_{D(\text{MAX})} = (T_{J(\text{MAX})} - T_A) / \theta_{JA} \quad (\text{EQ. 6})$$

$\theta_{JA}$  is the junction-to-ambient thermal resistance.

For safe operation, ensure that the power dissipation  $P_D$ , calculated from Equation 5, is less than the maximum allowable power dissipation  $P_{D(\text{MAX})}$ .

The DFN package uses the copper area on the PCB as a heat-sink. The EPAD of this package must be soldered to the copper plane (GND plane). Figure 13 shows a curve for the  $\theta_{JA}$  of the DFN package for different copper area sizes.

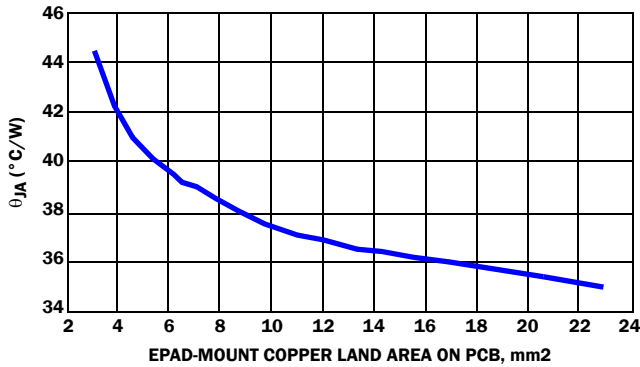

FIGURE 13. 3mmx3mm 10 LD DFN ON 4-LAYER PCB WITH THERMAL VIAS  $\theta_{JA}$  vs EPAD-MOUNT COPPER LAND AREA ON PCB

## Thermal Fault Protection

The power level and the thermal impedance of the package (+48 °C/W for DFN) determine when the junction temperature exceeds the thermal shutdown temperature. In the event that the die temperature exceeds around +160 °C, the output of the LDO will shut down until the die temperature cools down to about +130 °C.

## General Power PAD Design Considerations

Figure 14 shows the recommended use of vias on the thermal pad to remove heat from the IC. This typical array populates the thermal pad footprint with vias spaced three times the radius distance from the center of each via. Small via size is advisable, but not to the extent that solder reflow becomes difficult.

All vias should be connected to the pad potential, with low thermal resistance for efficient heat transfer. Complete connection of the plated through-hole to each plane is important. It is not recommended to use “thermal relief” patterns to connect the vias.

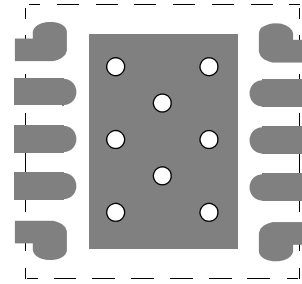

FIGURE 14. PCB VIA PATTERN

## Revision History

The revision history provided is for informational purposes only and is believed to be accurate, but not warranted. Please go to web to make sure you have the latest revision.

| DATE    | REVISION | CHANGE  |
|---------|----------|---|
| 6/6/12  | FN7713.5 | 1. Changed POD L10.3X3 on page 12 to latest revision from 6 to 7. Change POD is as follows:<br>Removed package outline and included center to center distance between lands on recommended land pattern. Removed Note 4 "Dimension b applies to the metalized terminal and is measured between 0.18mm and 0.30mm from the terminal tip." since it is not applicable to this package. Renumbered notes accordingly.  |
| 5/29/12 |          | 1. "Input Voltage Requirements" on page 7 changed input voltages from "2.2V" to "5V"  |
| 5/23/12 |          | 1. Page 1: On 3rd paragraphs first sentence "CMOS" changed to "BiCMOS".<br>2. Page1: 1st paragraph sentence changed from: "This LDO operates from input voltages of 2.2V to 6V. The ISL80121-5 has a nominal output voltage of 5V". TO: "The ISL80121-5 operates from input voltages of 5V to 6V with a nominal output voltage of 5V".<br>3. Page 2: Removed Note in Ordering Information: "The 1.5V, 3.3V and 5V fixed output voltages will be released in the future. Please contact Intersil Marketing for more details".<br>4. Page 4: Recommended Operation Conditions " $V_{IN}$ relative to GND changed from 2.2V to 6V to 5V to 6V"<br>5. Page 4: Recommended Operation Conditions Removed " $V_{OUT}$ Range line 800mV TO 5V"  |
| 9/19/11 | FN7713.4 | Table 1 on page 1 updated to include more information on Intersil's 1A LDO portfolio.   |
| 4/22/11 | FN7713.3 | In Figure 8 on page 7, corrected label from " $V_{OUT}$ (50V/DIV)." to " $V_{OUT}$ (50mV/DIV)."<br>In "DC Output Voltage Accuracy" on page 4, corrected the MAX value from -1.8 to +1.8.  |
| 2/1/11  | FN7713.2 | 1. page 1, paragraph 2. "The programmable current limiting improves system reliability of applications" changed to "The programmable current limiting improves system reliability of end applications."<br>2. page 1, Features, "Programmable Soft-starting" changed to "Programmable Soft-Start"<br>3. Made subbing consistent throughout document.<br>4. page 3, EPAD Description "directly to GND plane is optional." Changed to "directly to GND plane is required for thermal considerations. See "Power Dissipation and Thermals" on page 9 for more details."<br>5. page 5, Removed Notes in Electrical Spec Table, which read:"Minimum capacitor of 10 $\mu$ F X5R/X7R on $V_{IN}$ and $V_{OUT}$ required for stability." and "If the current limit for in-rush current is acceptable in application, do not use this feature. Used only when large bulk capacitance required on $V_{OUT}$ for application."<br>6. page 5, Electrical Specifications, PG Pin Characteristics, $V_{out}$ PG Flag Threshold<br>a. Typical "85" changed to "84" % $V_{out}$<br>7. page 9, after Thermal Fault Protection section<br>a. Added "General Power PAD Design Considerations" section with Figure 14.<br>8. All PGOOD changed to PG throughout. |
| 1/28/11 |          | Changed Theta Ja from 51C/W to 48C/W.   |
| 1/25/11 |          | 1. page 1, Features<br>a. "200 $\mu$ Vrms Output Noise" changed to "210 $\mu$ Vrms Output Noise"<br>2. page 1, Typical Applications, right side figure<br>a. Resize " $V_{OUT}$ " (pin2) and "SENSE" (pin3)<br>3. page 8, Equation 4<br>a. Extra parenthesis ")" removed  |
| 1/21/11 |          | page 1 Before Features added Table of Key Differences.<br>page 2 Block Diagram - Removed "ADJ Voltage Version" and left the "Sense" Connection.<br>page 3 Pin Number 8, description, 2nd sentence: "Current limit is 0.75mA..." changed to "Current limit is 0.75A..."<br>page 4 Electrical Specifications, AC Characteristics, Input Supply Ripple Rejection Test conditions and Typical values changed from "f = 1kHz, ILOAD = 1A, f = 120Hz, ILOAD = 1A"<br>TO "f = 1kHz, ILOAD = 1A, f = 1kHz, ILOAD = 100mA"<br>page 6, Figure 3 - X-axis label changed from "Output Current (mA)" to "Output Current (A)"<br>page 8, Figure 12 - a. Figure label change. "IN" in " $V_{IN}$ " was subscripted.  |
| 12/6/10 | FN7713.1 | 1. In "Block Diagram" on page 2:<br>a. Added "ADJ adjustable voltage version" Pin. Added "fixed voltage version" to "SENSE" pin<br>2. On page 4: "Ground Pin Current" Test Conditions<br>a. Replaced " $V_{OUT}+0.4V$ " with "2.2V" on both lines   |
| 12/2/10 | FN7713.0 | Initial Release.  |

## Products

Intersil Corporation is a leader in the design and manufacture of high-performance analog semiconductors. The Company's products address some of the industry's fastest growing markets, such as, flat panel displays, cell phones, handheld products, and notebooks. Intersil's product families address power management and analog signal processing functions. Go to [www.intersil.com/products](http://www.intersil.com/products) for a complete list of Intersil product families.

For a complete listing of Applications, Related Documentation and Related Parts, please see the respective device information page on [intersil.com](http://intersil.com): [ISL80121-5](http://intersil.com/ISL80121-5)

To report errors or suggestions for this data sheet, please go to: [www.intersil.com/askourstaff](http://www.intersil.com/askourstaff)

FITs are available from our web site at: <http://rel.intersil.com/reports/search.php>

---

For additional products, see [www.intersil.com/product\\_tree](http://www.intersil.com/product_tree)

---

Intersil products are manufactured, assembled and tested utilizing ISO9000 quality systems as noted in the quality certifications found at [www.intersil.com/design/quality](http://www.intersil.com/design/quality)

---

*Intersil products are sold by description only. Intersil Corporation reserves the right to make changes in circuit design, software and/or specifications at any time without notice. Accordingly, the reader is cautioned to verify that data sheets are current before placing orders. Information furnished by Intersil is believed to be accurate and reliable. However, no responsibility is assumed by Intersil or its subsidiaries for its use; nor for any infringements of patents or other rights of third parties which may result from its use. No license is granted by implication or otherwise under any patent or patent rights of Intersil or its subsidiaries.*

---

For information regarding Intersil Corporation and its products, see [www.intersil.com](http://www.intersil.com)

## Package Outline Drawing

### L10.3x3

10 LEAD DUAL FLAT PACKAGE (DFN)

Rev 7, 10/11

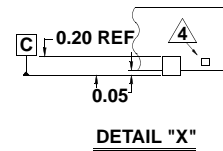
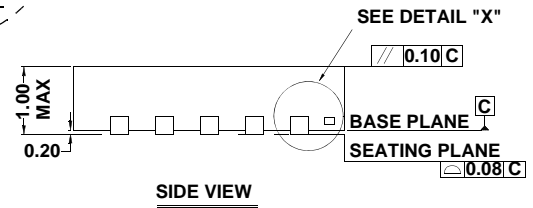
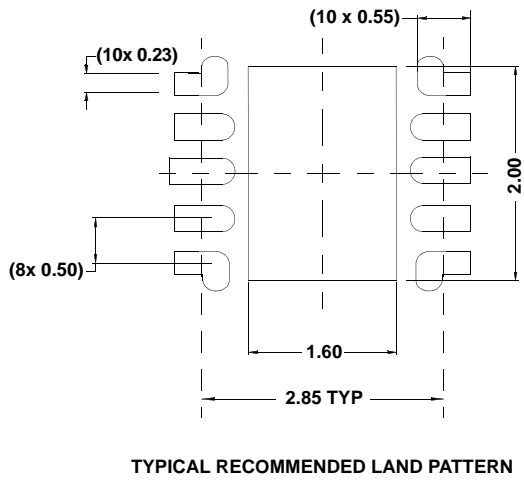
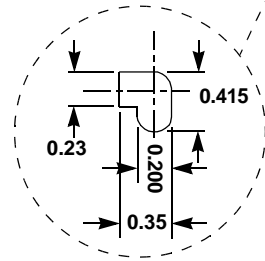
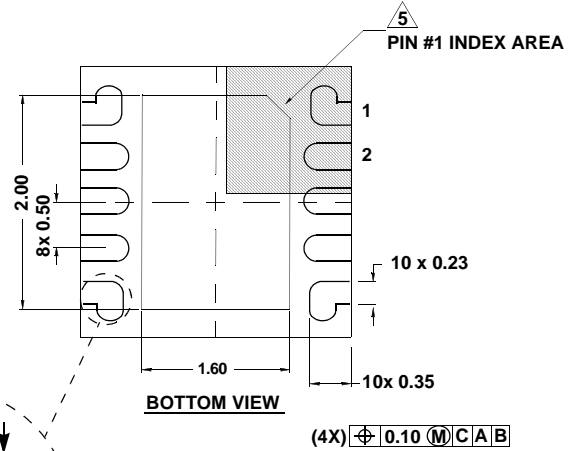
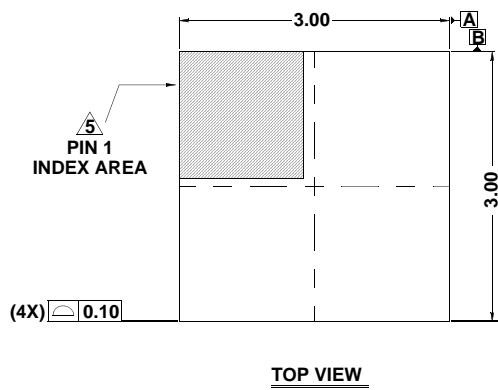

#### NOTES:

- Dimensions are in millimeters.  
Dimensions in ( ) for Reference Only.
- Dimensioning and tolerancing conform to AMSE Y14.5m-1994.
- Unless otherwise specified, tolerance : Decimal  $\pm 0.05$
- Tiebar shown (if present) is a non-functional feature.
- The configuration of the pin #1 identifier is optional, but must be located within the zone indicated. The pin #1 identifier may be either a mold or mark feature.