

High Speed, Dual Channel, 6A, Power MOSFET Driver With Programmable Delays

ISL89166, ISL89167, ISL89168

The ISL89166, ISL89167, and ISL89168 are high-speed, 6A, dual channel MOSFET drivers. These parts are similar to the ISL89160, ISL89161, ISL89162 drivers but use the NC pins for programming the rising edge time delays of the outputs used for dead time control.

As an alternative to using external RC circuits for time delays, the programmable delays on the RDTA and RDTB pins allows the user to delay the rising edge of the respective outputs just by connecting an appropriate resistor value between these pins and ground. The accuracy and temperature characteristics of the time delays are specified freeing the user of the need to select appropriate external resistors and capacitors that traditionally are applied to the logic inputs to delay the output edges.

At high switching frequencies, these MOSFET drivers use very little internal bias currents. Separate, non-overlapping drive circuits are used to drive each CMOS output FET to prevent shoot-thru currents in the output stage.

The start-up sequence is design to prevent unexpected glitches when V_{DD} is being turned on or turned off. When $V_{DD} < \sim 1V$, an internal $10k\Omega$ resistor between the output and ground helps to keep the output voltage low. When $\sim 1V < V_{DD} < UV$, both outputs are driven low with very low resistance and the logic inputs are ignored. This insures that the driven FETs are off. When $V_{DD} > UVLO$, and after a short delay, the outputs now respond to the logic inputs.

Features

- Typical ON-resistance $< 1\Omega$
- Specified Miller plateau drive currents
- Very low thermal impedance ($\theta_{JC} = 3^\circ C/W$)
- Hysteretic Input logic levels for 3.3V CMOS, 5V CMOS, and TTL
- Precision threshold inputs for optional time delays with external RC components
- Instead of RC components for time delays, a resistor can be used to program delays
- 20ns rise and fall time driving a 10nF load.
- NC pins may be connected to ground or VDD for flexible PCB layout options

Applications

- Synchronous Rectifier (SR) Driver
- Switch mode power supplies
- Motor Drives, Class D amplifiers, UPS, Inverters
- Pulse Transformer Driver
- Clock/Line Driver

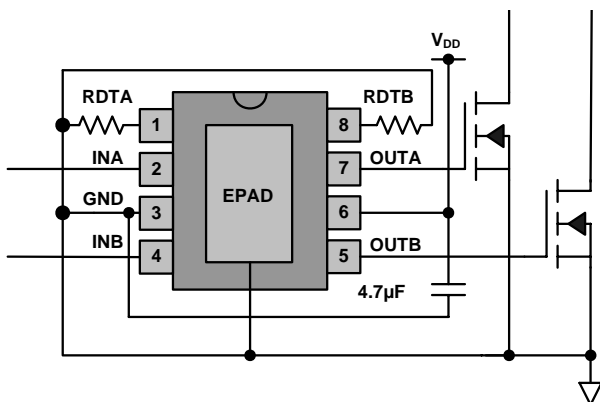

FIGURE 1. TYPICAL APPLICATION

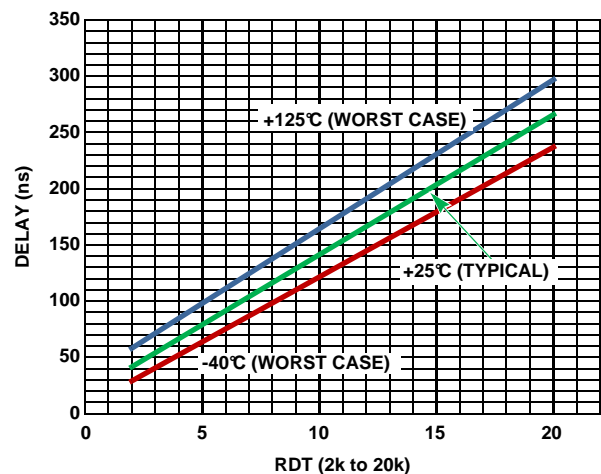
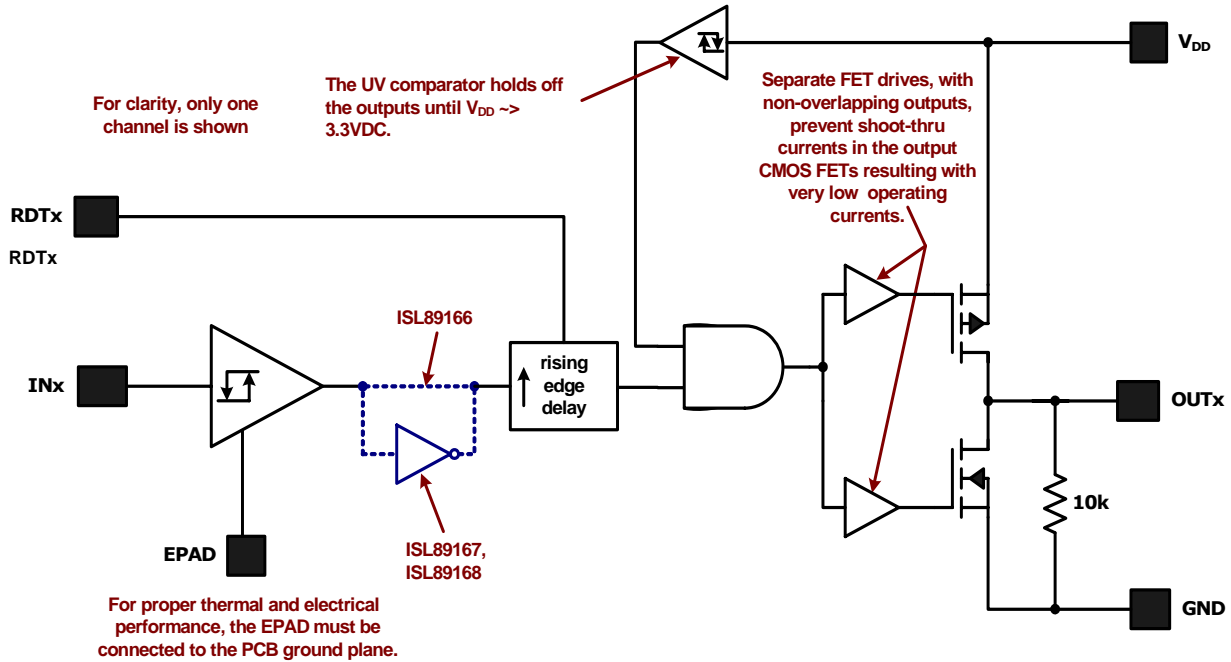

FIGURE 2. PROGRAMMABLE TIME DELAYS

ISL89166, ISL89167, ISL89168

Block Diagram



Pin Configurations

ISL89166FR, ISL89166FB
(8 LD TDFN, EPSONIC)
TOP VIEW

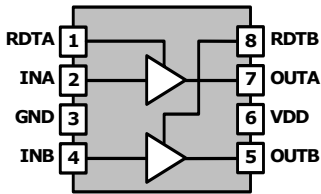

ISL89167FR, ISL89167FB
(8 LD TDFN, EPSONIC)
TOP VIEW

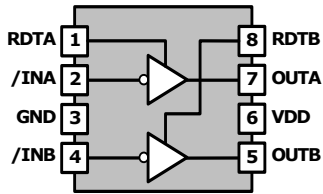

ISL89168FR, ISL89168FB
(8 LD TDFN, EPSONIC)
TOP VIEW

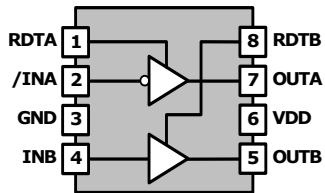

Pin Descriptions

PIN NUMBER	SYMBOL	DESCRIPTION
1	RDTA	Connect a resistor between this pin and ground to program the rising edge delay of OUTA, 0k to 20k
2	INA or /INA	Channel A input, 0V to VDD
3	GND	Power Ground, 0V
4	INB or /INB	Channel B enable, 0V to VDD
5	OUTB	Channel B output
6	VDD	Power input, 4.5V to 16V
7	OUTA	Channel A output, 0V to VDD
8	RDTB	Connect a resistor between this pin and ground to program the rising edge delay of OUTB, 0k to 20k
	EPAD	Power Ground, 0V

ISL89166, ISL89167, ISL89168

Ordering Information

PART NUMBER (Notes 1, 2, 3)	PART MARKING	TEMP RANGE (°C)	INPUT CONFIGURATION	PACKAGE (Pb-Free)	PKG. DWG. #
ISL89166FRTAZ	166A	-40 to +125	non-inverting	8 Ld 3x3 TDFN	L8.3x3I
ISL89167FRTAZ	167A	-40 to +125	inverting	8 Ld 3x3 TDFN	L8.3x3I
ISL89168FRTAZ	168A	-40 to +125	inverting + non-inverting	8 Ld 3x3 TDFN	L8.3x3I
ISL89166FRTBZ	166B	-40 to +125	non-inverting	8 Ld 3x3 TDFN	L8.3x3I
ISL89167FRTBZ	167B	-40 to +125	inverting	8 Ld 3x3 TDFN	L8.3x3I
ISL89168FRTBZ	168B	-40 to +125	inverting + non-inverting	8 Ld 3x3 TDFN	L8.3x3I
ISL89166FRTCZ	166C	-40 to +125	non-inverting	8 Ld 3x3 TDFN	L8.3x3I
ISL89167FRTCZ	167C	-40 to +125	inverting	8 Ld 3x3 TDFN	L8.3x3I
ISL89168FRTCZ	168C	-40 to +125	inverting + non-inverting	8 Ld 3x3 TDFN	L8.3x3I
ISL89166FBEAZ	89166 FBEAZ	-40 to +125	non-inverting	8 Ld EPOIC	M8.15D
ISL89167FBEAZ	89167 FBEAZ	-40 to +125	inverting	8 Ld EPOIC	M8.15D
ISL89168FBEAZ	89168 FBEAZ	-40 to +125	inverting + non-inverting	8 Ld EPOIC	M8.15D
ISL89166FBEBZ	89166 FBEBZ	-40 to +125	non-inverting	8 Ld EPOIC	M8.15D
ISL89167FBEBZ	89167 FBEBZ	-40 to +125	inverting	8 Ld EPOIC	M8.15D
ISL89168FBEBZ	89168 FBEBZ	-40 to +125	inverting + non-inverting	8 Ld EPOIC	M8.15D
ISL89166FBECZ	89166 FBECZ	-40 to +125	non-inverting	8 Ld EPOIC	M8.15D
ISL89167FBECZ	89167 FBECZ	-40 to +125	inverting	8 Ld EPOIC	M8.15D
ISL89168FBECZ	89168 FBECZ	-40 to +125	inverting + non-inverting	8 Ld EPOIC	M8.15D

NOTES:

1. Add "-T*" suffix for tape and reel. Please refer to [TB347](#) for details on reel specifications.
2. These Intersil Pb-free plastic packaged products employ special Pb-free material sets, molding compounds/die attach materials, and 100% matte tin plate plus anneal (e3 termination finish, which is RoHS compliant and compatible with both SnPb and Pb-free soldering operations). Intersil Pb-free products are MSL classified at Pb-free peak reflow temperatures that meet or exceed the Pb-free requirements of IPC/JEDEC J STD-020.
3. For Moisture Sensitivity Level (MSL), please see device information page for [ISL89166](#), [ISL89167](#), [ISL89168](#). For more information on MSL, please see Technical Brief [TB363](#).

ISL89166, ISL89167, ISL89168

Absolute Maximum Ratings

Supply Voltage, V_{DD} Relative to GND	-0.3V to 18V
Logic Inputs (INA, INB)	GND - 0.3V to $V_{DD} + 0.3V$
Outputs (OUTA, OUTB)	GND - 0.3V to $V_{DD} + 0.3V$
Average Output Current (Note 6)	150mA

ESD Ratings

Human Body Model Class 2 (Tested per JESD22-A114E)	2000V
Machine Model Class B (Tested per JESD22-A115-A)	200V
Charged Device Model Class IV	1500V

Latch-Up

(Tested per JESD-78B; Class 2, Level A)	
Output Current	500mA

Thermal Information

Thermal Resistance (Typical)	θ_{JA} ($^{\circ}C/W$)	θ_{JC} ($^{\circ}C/W$)
8 Ld TDFN Package (Notes 4, 5)	44	3
8 Ld EPSON Package (Notes 4, 5)	42	3
Max Power Dissipation at +25 $^{\circ}C$ in Free Air	2.27W	
Max Power Dissipation at +25 $^{\circ}C$ with Copper Plane	33.3W	
Storage Temperature Range	-65 $^{\circ}C$ to +150 $^{\circ}C$	
Operating Junction Temp Range	-40 $^{\circ}C$ to +125 $^{\circ}C$	
Pb-Free Reflow Profile	see link below http://www.intersil.com/pbfree/Pb-FreeReflow.asp	

Maximum Recommended Operating Conditions

Junction Temperature	-40 $^{\circ}C$ to +125 $^{\circ}C$
Supply Voltage, V_{DD} Relative to GND	4.5V to 16V
Logic Inputs (INA, INB)	0V to V_{DD}
Outputs (OUTA, OUTB)	0V to V_{DD}

CAUTION: Do not operate at or near the maximum ratings listed for extended periods of time. Exposure to such conditions may adversely impact product reliability and result in failures not covered by warranty

NOTES:

- θ_{JA} is measured in free air with the component mounted on a high effective thermal conductivity test board with "direct attach" features. See Tech Brief TB379 for details.
- For θ_{JC} , the "case temp" location is the center of the exposed metal pad on the package underside.
- The average output current, when driving a power MOSFET or similar capacitive load, is the average of the rectified output current. The peak output currents of this driver are self limiting by transconductance or $r_{DS(ON)}$ and do not require any external components to minimize the peaks. If the output is driving a non-capacitive load, such as an LED, maximum output current must be limited by external means to less than the specified absolute maximum.

DC Electrical Specifications $V_{DD} = 12V$, $GND = 0V$, No load on OUTA or OUTB, $R_{DTA} = R_{DTB} = 0k\Omega$ unless otherwise specified. Boldface limits apply over the operating junction temperature range, -40 $^{\circ}C$ to +125 $^{\circ}C$.

PARAMETERS	SYMBOL	TEST CONDITIONS	$T_J = +25^{\circ}C$			$T_J = -40^{\circ}C$ to +125 $^{\circ}C$		UNITS
			MIN	TYP	MAX	MIN (Note 7)	MAX (Note 7)	
POWER SUPPLY								
Voltage Range	V_{DD}		-	-	-	4.5	16	V
V_{DD} Quiescent Current	I_{DD}	INx = GND	-	5	-	-	-	mA
		INA = INB = 1MHz, square wave	-	25	-	-	-	mA
UNDERVOLTAGE								
VDD Undervoltage Lock-out (Note 9) (Figure 9)	V_{UV}	INA = INB = True (Note 10)	-	3.3	-	-	-	V
Hysteresis			-	~25	-	-	-	mV
INPUTS								
Input Range for INA, INB	V_{IN}		-	-	-	GND	V_{DD}	V
Logic 0 Threshold for INA, INB	V_{IL}	Nominally 37% x 3.3V	-	1.22	-	1.12	1.32	V
Logic 1 Threshold for INA, INB	V_{IH}	Nominally 63% x 3.3V	-	2.08	-	1.98	2.18	V
Input Capacitance of INA, INB (Note 8)	C_{IN}		-	2	-	-	-	pF

ISL89166, ISL89167, ISL89168

DC Electrical Specifications $V_{DD} = 12V$, $GND = 0V$, No load on OUTA or OUTB, $R_{DTA} = R_{DTB} = 0k\Omega$ unless otherwise specified. **Boldface limits apply over the operating junction temperature range, -40°C to +125°C. (Continued)**

PARAMETERS	SYMBOL	TEST CONDITIONS	$T_J = +25^\circ C$			$T_J = -40^\circ C \text{ to } +125^\circ C$		UNITS
			MIN	TYP	MAX	MIN (Note 7)	MAX (Note 7)	
Input Bias Current for INA, INB	I_{IN}	$GND < V_{IN} < V_{DD}$	-	-	-	-10	+10	μA
OUTPUTS								
High Level Output Voltage	V_{OHA} V_{OHB}		-	-	-	$V_{DD} - 0.1$	V_{DD}	V
Low Level Output Voltage	V_{OLA} V_{OLB}		-	-	-	GND	GND + 0.1	V
Peak Output Source Current	I_O	V_O (initial) = 0V, $C_{LOAD} = 10nF$	-	-6	-	-	-	A
Peak Output Sink Current	I_O	V_O (initial) = 12V, $C_{LOAD} = 10nF$	-	+6	-	-	-	A

NOTES:

- Compliance to datasheet limits is assured by one or more methods: production test, characterization and/or design.
- This parameter is taken from the simulation models for the input FET. The actual capacitance on this input will be dominated by the PCB parasitic capacitance.
- A 400 μs delay further inhibits the release of the output state when the UV positive going threshold is crossed. See Figure 9
- The true state of a specific part number is defined by the input logic symbol.

AC Electrical Specifications $V_{DD} = 12V$, $GND = 0V$, No Load on OUTA or OUTB, $R_{DTA} = R_{DTB} = 0k\Omega$ unless Otherwise Specified. **Boldface limits apply over the operating junction temperature range, -40°C to +125°C.**

PARAMETERS	SYMBOL	TEST CONDITIONS /NOTES	$T_J = +25^\circ C$			$T_J = -40^\circ C \text{ to } +125^\circ C$		UNITS
			MIN	TYP	MAX	MIN (Note 7)	MAX (Note 7)	
Output Rise Time (see Figure 4)	t_R	$C_{LOAD} = 10nF$, 10% to 90%	-	20	-	-	40	ns
Output Fall Time (see Figure 4)	t_F	$C_{LOAD} = 10nF$, 90% to 10%	-	20	-	-	40	ns
Output Rising Edge Propagation Delay (see Figure 3)	t_{RDLY}	$R_{DTx} = 0k\Omega$	-	25	-	-	50	ns
Output Falling Edge Propagation Delay (see Figure 3) (Note 12)	t_{FDLY}	$R_{DTx} = 0k\Omega$	-	25	-	-	50	ns
Rising Propagation Matching (see Figure 3)	t_{RM}	$R_{DTx} = 0k\Omega$	-	<1ns	-	-	-	ns
Falling Propagation Matching (see Figure 3)	t_{FM}	$R_{DTx} = 0k\Omega$	-	<1ns	-	-	-	ns
Rising edge timer delay (Note 11)	$t_{RTDLY20}$	$R_{Tx} = 20k\Omega$, No load	-	266	-	237	297	ns
	t_{RTDLY2}	$R_{Tx} = 2.0k\Omega$, No load	-	42	-	29	58	ns
Miller Plateau Sink Current (See Test Circuit Figure 5)	$-I_{MP}$	$V_{DD} = 10V$, $V_{MILLER} = 5V$	-	6	-	-	-	A
	$-I_{MP}$	$V_{DD} = 10V$, $V_{MILLER} = 3V$	-	4.7	-	-	-	A
	$-I_{MP}$	$V_{DD} = 10V$, $V_{MILLER} = 2V$	-	3.7	-	-	-	A

ISL89166, ISL89167, ISL89168

AC Electrical Specifications $V_{DD} = 12V$, $GND = 0V$, No Load on OUTA or OUTB, $R_{DTA} = R_{DTB} = 0k\Omega$ unless Otherwise Specified. **Boldface limits apply over the operating junction temperature range, $-40^{\circ}C$ to $+125^{\circ}C$.** (Continued)

PARAMETERS	SYMBOL	TEST CONDITIONS /NOTES	$T_J = +25^{\circ}C$			$T_J = -40^{\circ}C$ to $+125^{\circ}C$		UNITS
			MIN	TYP	MAX	MIN (Note 7)	MAX (Note 7)	
Miller Plateau Source Current (See Test Circuit Figure 6)	I_{MP}	$V_{DD} = 10V$, $V_{MILLER} = 5V$	-	5.2	-	-	-	A
	I_{MP}	$V_{DD} = 10V$, $V_{MILLER} = 3V$	-	5.8	-	-	-	A
	I_{MP}	$V_{DD} = 10V$, $V_{MILLER} = 2V$	-	6.9	-	-	-	A

NOTE:

- The rising edge delay timer increases the propagation delay for values of $R_{DTx} > 2.0k\Omega$. Time delays for $R_{DTx} < 2.0k\Omega$ and $R_{DTx} > 20k\Omega$ are not specified and are not recommended. The resistors tolerances (including the boundary values of $2.0k\Omega$ and $20.0k\Omega$) are recommended to be 1% or better.
- The falling edge propagation delays are independent of the RDT value.

Test Waveforms and Circuits

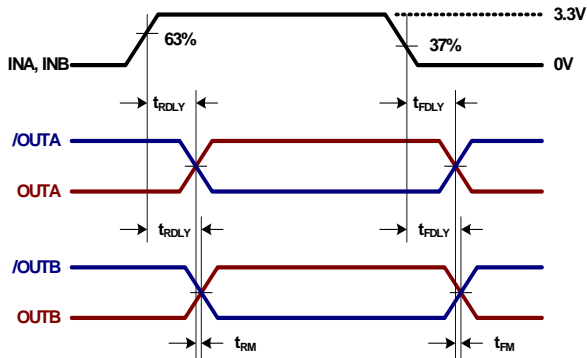

FIGURE 3. PROP DELAYS AND MATCHING

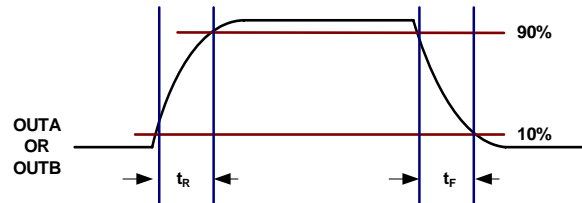

FIGURE 4. RISE/FALL TIMES

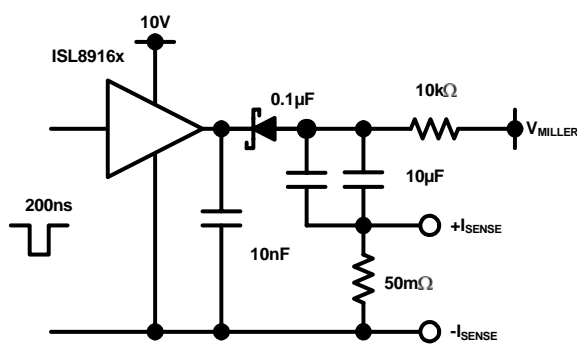

FIGURE 5. MILLER PLATEAU SINK CURRENT TEST CIRCUIT

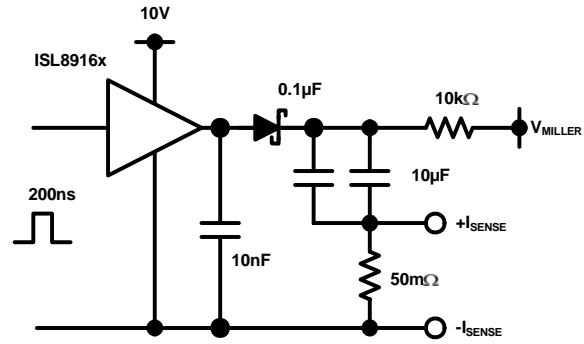

FIGURE 6. MILLER PLATEAU SOURCE CURRENT TEST CIRCUIT

Test Waveforms and Circuits (Continued)

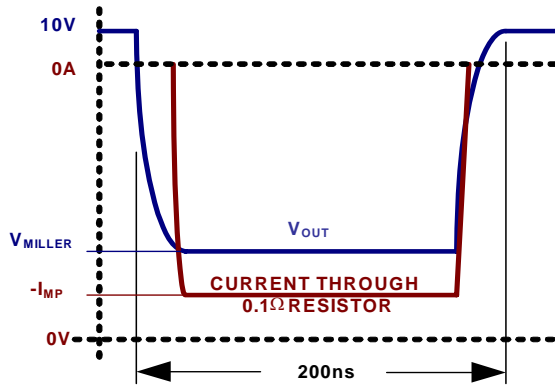

FIGURE 7. MILLER PLATEAU SINK CURRENT

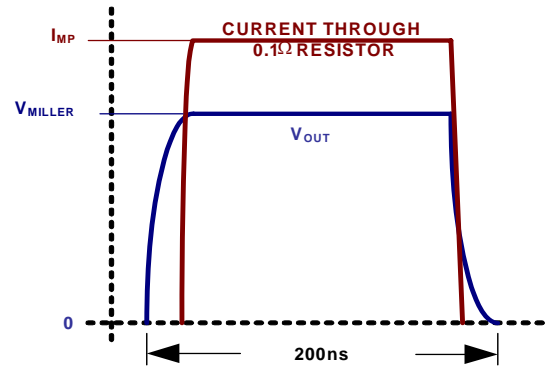

FIGURE 8. MILLER PLATEAU SOURCE CURRENT

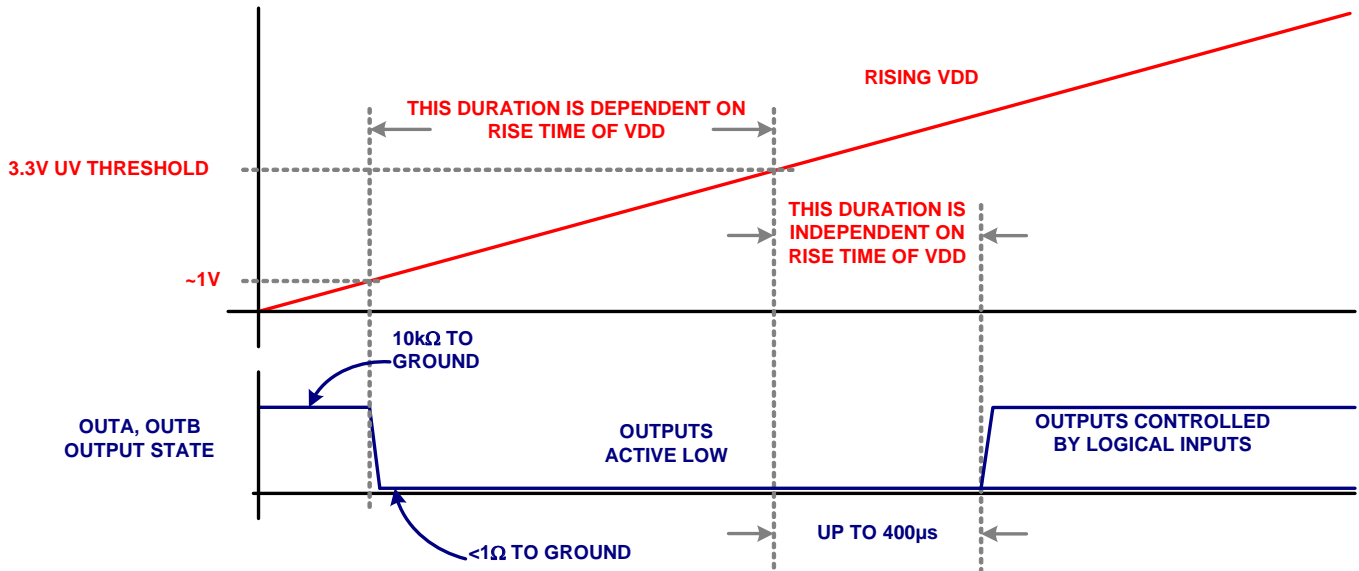

FIGURE 9. START-UP SEQUENCE

Typical Performance Curves

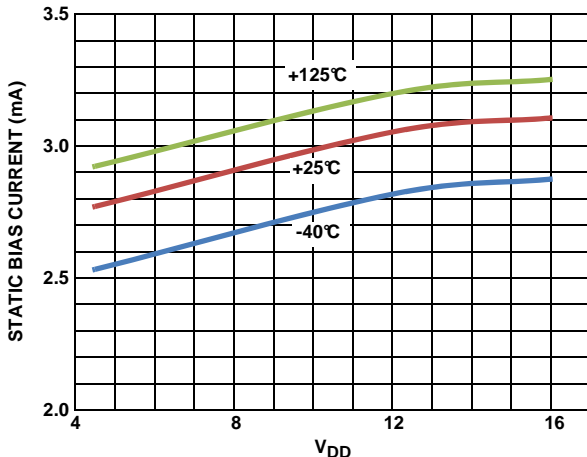

FIGURE 10. I_{DD} vs V_{DD} (STATIC)

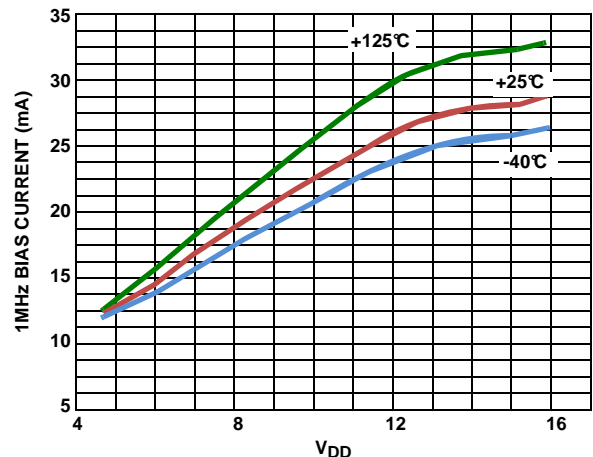

FIGURE 11. I_{DD} vs V_{DD} (1MHz)

Typical Performance Curves (Continued)

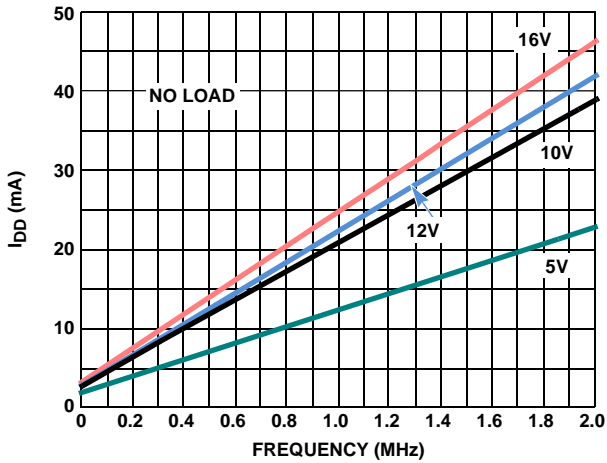

FIGURE 12. I_{DD} vs FREQUENCY (+25°C)

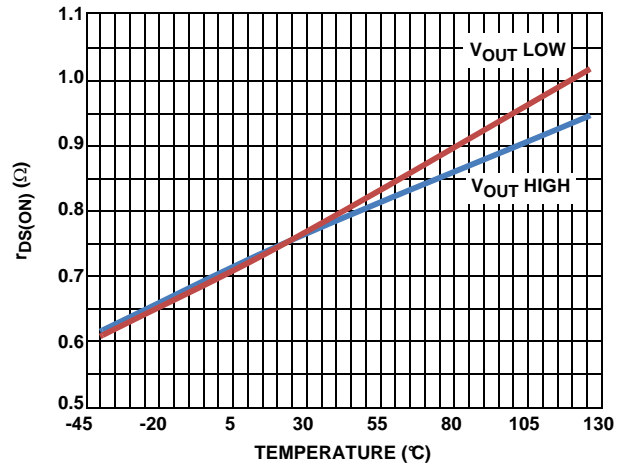

FIGURE 13. $r_{DS(ON)}$ vs TEMPERATURE

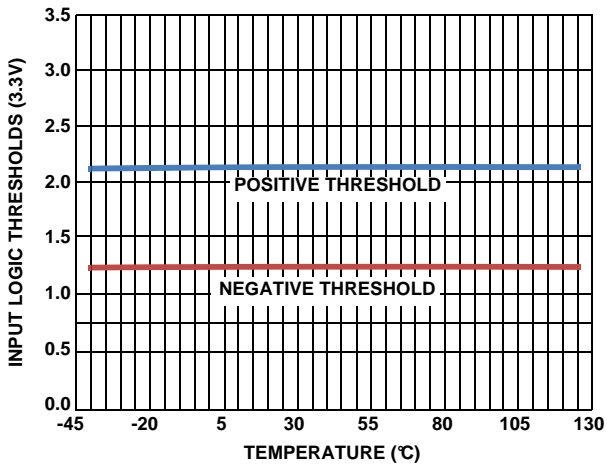

FIGURE 14. INPUT THRESHOLDS

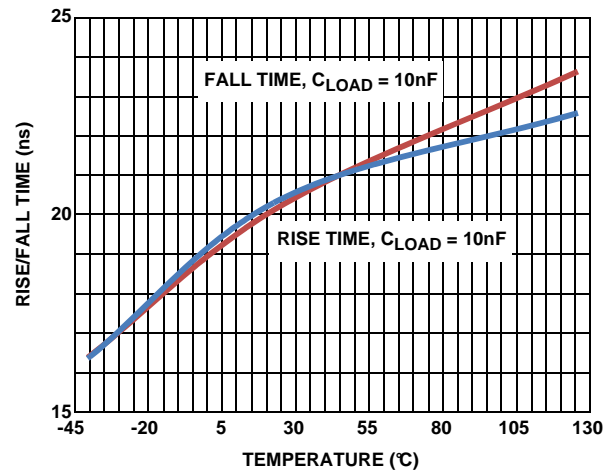

FIGURE 15. OUTPUT RISE/FALL TIME

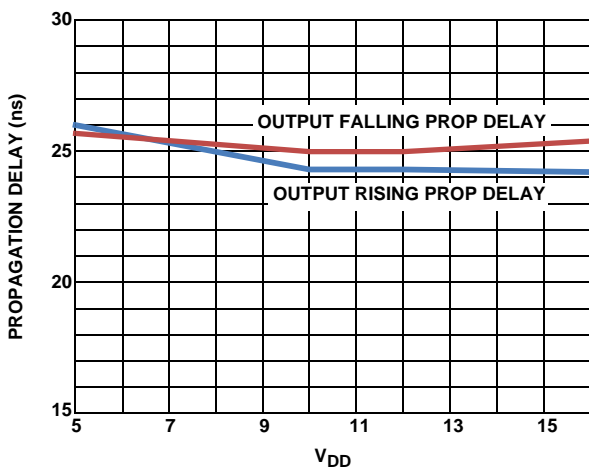

FIGURE 16. PROPAGATION DELAY vs V_{DD}

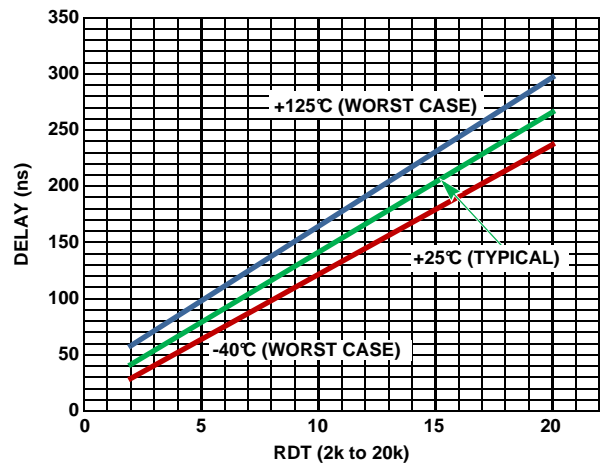

FIGURE 17. PROPAGATION DELAY vs RDT

Functional Description

Overview

The ISL89166, ISL89167, ISL89168 drivers incorporate several features including precision input logic thresholds, undervoltage lock-out, fast rising high output drive currents and programmable rising edge output delays.

The programmable delays require only a resistor connector between the RDTA or RDTB pins and ground. This is a useful feature to create dead times for bridge applications to prevent shoot-through or for synchronous rectifier applications to adjust the timing.

Fast rising (or falling) output drive current of the ISL89166, ISL89167, ISL89168 minimizes the turn-on (off) delay due to the input capacitance of the driven FET. The switching transition period at the Miller plateau is also minimized by the high drive currents. (See the specified Miller plateau currents in the AC Electrical Specifications on page 5).

The start-up sequence for is designed to prevent unexpected glitches when V_{DD} is being turned on or turned off. When $V_{DD} < \sim 1V$, an internal $10k\Omega$ resistor connected between the output and ground, help to keep the gate voltage close to ground. When $\sim 1V < V_{DD} < UV$, both outputs are driven low while ignoring the logic inputs. This low state has the same current sinking capacity as during normal operation. This insures that the driven FETs are held off even if there is a switching voltage on the drains that can inject charge into the gates via the Miller capacitance. When $V_{DD} > UVLO$, and after a $400\mu s$ delay, the outputs now respond to the logic inputs. See Figure 9 for complete details.

For the negative transition of V_{DD} through the UV lockout voltage, the outputs are active low when $V_{DD} < \sim 3.2V_{DC}$ regardless of the input logic states.

Application Information

Programming Rising Edge Delays

As compared to setting the output delays of a driver using an resistor, capacitor and diode on the logic inputs, programming the rising edge output delays of the ISL89166, ISL89167, ISL89168 is almost trivial.

All that is necessary is to select the required resistor value from the Propagation Delay vs RDT graph, Figure 17. Unlike using an RCD network, the operating tolerances over temperature are specified. If a traditional RCD network (Figure 19) is used on the input logic, then it is necessary to account for the tolerance of the logic input threshold, the tolerances of R and C, and their temperature sensitivity.

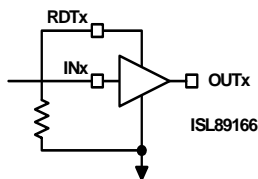

FIGURE 18. SETTING DELAYS WITH A RESISTOR

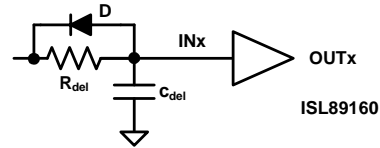

FIGURE 19. SETTING DELAYS WITH A RCD NETWORK

Paralleling Outputs to Double the Peak Drive Currents

The typical propagation matching of the ISL89166 and ISL89167 is less than 1ns. Note that the propagation matching is only valid when $RTDA$ and $RTDB = 0k\Omega$. The matching is so precise that carefully matched and calibrated scopes probes and scope channels must be used to make this measurement. Because of this excellent performance, these driver outputs can be safely paralleled to double the current drive capacity. It is important that the INA and INB inputs be connected together on the PCB with the shortest possible trace. This is also required of OUTA and OUTB. Note that the ISL89168 cannot be paralleled because of the complementary logic.

Power Dissipation of the Driver

The power dissipation of the ISL89166, ISL89167, ISL89168 is dominated by the losses associated with the gate charge of the driven bridge FETs and the switching frequency. The internal bias current also contributes to the total dissipation but is usually not significant as compared to the gate charge losses.

Figure 20 illustrates how the gate charge varies with the gate voltage in a typical power MOSFET. In this example, the total gate charge for $V_{GS} = 10V$ is $21.5nC$ when $V_{DS} = 40V$. This is the charge that a driver must source to turn-on the MOSFET and must sink to turn-off the MOSFET.

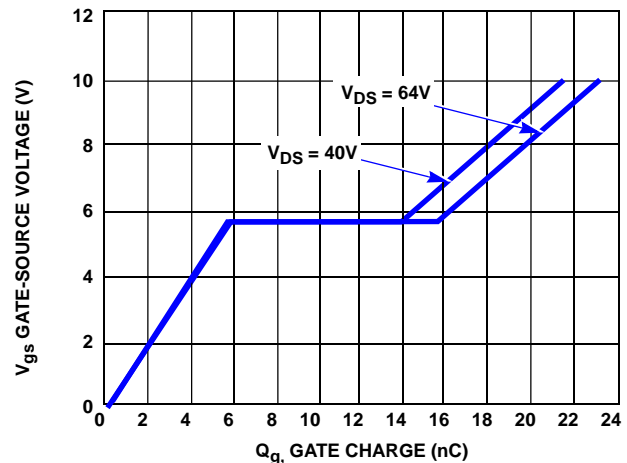

FIGURE 20. MOSFET GATE CHARGE vs GATE VOLTAGE

Equation 1 shows calculating the power dissipation of the driver:

$$P_D = 2 \cdot Q_c \cdot \text{freq} \cdot V_{GS} \cdot \frac{R_{gate}}{R_{gate} + r_{DS(ON)}} + I_{DD}(\text{freq}) \cdot V_{DD} \quad (\text{EQ. 1})$$

ISL89166, ISL89167, ISL89168

Where:

freq = Switching frequency,

$V_{GS} = V_{DD}$ bias of the ISL89166, ISL89167, ISL89168

Q_c = Gate charge for V_{GS}

$I_{DD}(freq)$ = Bias current at the switching frequency (see Figure 10 on page 7)

$r_{DS(ON)}$ = ON-resistance of the driver

R_{gate} = External gate resistance (if any).

Note that the gate power dissipation is proportionally shared with the external gate resistor. When sizing an external gate resistor, do not overlook the power dissipated by this resistor.

Typical Application Circuit

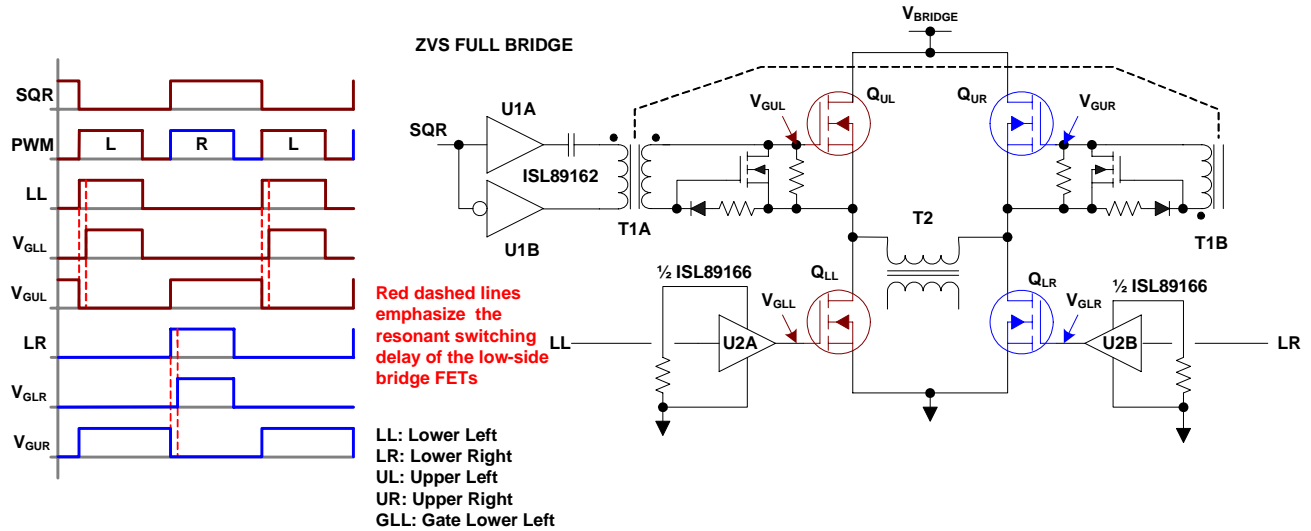

ISL89166, ISL89167, ISL89168

The Typical Application Circuit is an example of how the ISL89166, ISL89167, ISL89168, MOSFET drivers can be applied in a zero voltage switching full bridge. Two main signals are required: a 50% duty cycle square wave (SQR) and a PWM signal synchronized to the edges of the SQR input. An ISL89162 is used to drive T1 with alternating half cycles driving Q_{UL} and Q_{UR} . An ISL89166 is used to drive Q_{LL} and Q_{LR} also with alternating half cycles. Unlike the two high side bridge FETs, the two low-side bridge FETs are turned on with a rising edge delay. The delay is setup by resistors connected to RDTA and RDTB pins of the ISL89166. The duration of the delay is chosen to turn on the low-side FETs when the voltage on their respective drains is at the resonant valley.

General PCB Layout Guidelines

The AC performance of the ISL89166, ISL89167, ISL89168 depends significantly on the design of the PC board. The following layout design guidelines are recommended to achieve optimum performance:

- Place the driver as close as possible to the driven power FET.
- Understand where the switching power currents flow. The high amplitude di/dt currents of the driven power FET will induce significant voltage transients on the associated traces.
- Keep power loops as short as possible by paralleling the source and return traces.
- Use planes where practical; they are usually more effective than parallel traces.
- Avoid paralleling high amplitude di/dt traces with low level signal lines. High di/dt will induce currents and consequently, noise voltages in the low level signal lines.
- When practical, minimize impedances in low level signal circuits. The noise, magnetically induced on a 10k resistor, is 10x larger than the noise on a 1k resistor.
- Be aware of magnetic fields emanating from transformers and inductors. Gaps in these structures are especially bad for emitting flux.
- If you must have traces close to magnetic devices, align the traces so that they are parallel to the flux lines to minimize coupling.
- The use of low inductance components such as chip resistors and chip capacitors is highly recommended.
- Use decoupling capacitors to reduce the influence of parasitic inductance in the VDD and GND leads. To be effective, these caps must also have the shortest possible conduction paths. If vias are used, connect several paralleled vias to reduce the inductance of the vias.
- It may be necessary to add resistance to dampen resonating parasitic circuits especially on OUTA and OUTB. If an external gate resistor is unacceptable, then the layout must be improved to minimize lead inductance.
- Keep high dv/dt nodes away from low level circuits. Guard banding can be used to shunt away dv/dt injected currents from sensitive circuits. This is especially true for control circuits

that source the input signals to the ISL89166, ISL89167, ISL89168.

- Avoid having a signal ground plane under a high amplitude dv/dt circuit. This will inject di/dt currents into the signal ground paths.
- Do power dissipation and voltage drop calculations of the power traces. Many PCB/CAD programs have built in tools for calculation of trace resistance.
- Large power components (Power FETs, Electrolytic caps, power resistors, etc.) will have internal parasitic inductance which cannot be eliminated. This must be accounted for in the PCB layout and circuit design.
- If you simulate your circuits, consider including parasitic components especially parasitic inductance.

General EPAD Heatsinking Considerations

The thermal pad is electrically connected to the GND supply through the IC substrate. The epad of the ISL89166, ISL89167, ISL89168 has two main functions: to provide a quiet GND for the input threshold comparators and to provide heat sinking for the IC. The EPAD must be connected to a ground plane and no switching currents from the driven FET should pass through the ground plane under the IC.

Figure 21 is a PCB layout example of how to use vias to remove heat from the IC through the epad.

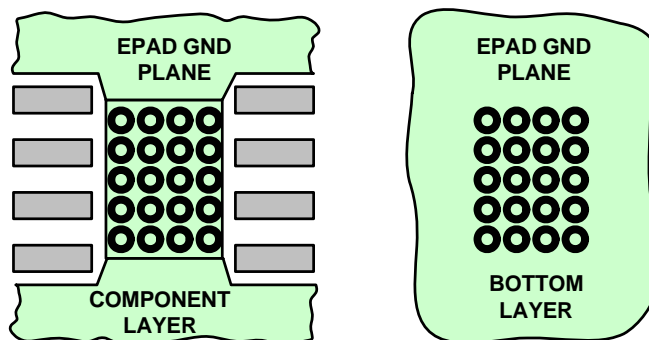

FIGURE 21. TYPICAL PCB PATTERN FOR THERMAL VIAS

For maximum heatsinking, it is recommended that a ground plane, connected to the EPAD, be added to both sides of the PCB. A via array, within the area of the EPAD, will conduct heat from the EPAD to the GND plane on the bottom layer. The number of vias and the size of the GND planes required for adequate heatsinking is determined by the power dissipated by the ISL89166, ISL89167, ISL89168, the air flow and the maximum temperature of the air around the IC.

ISL89166, ISL89167, ISL89168

Revision History

The revision history provided is for informational purposes only and is believed to be accurate, but not warranted. Please go to web to make sure you have the latest Rev.

DATE	REVISION	CHANGE
January 31, 2012	FN7720.1	(page 1) Figure 1 illustration improved. (page 1) Last paragraph of the product description is changed to better describe the improved turn on characteristics. (page 1) Features list is revised to improve readability and to add new product specific features. (page 3) Updated Ordering information with new parts. (page 4) Abs Max Ratings ESD Ratings Charged Device Model changed from "1000" to "1500" (page 4) Note and figure references are added to the VDD Under-voltage lock-out parameter. (page 5) Note 9 is revised to more clearly describe the turn-on characteristics. Changed "200us" to "400us" (page 6) Wording of Note 11 is revised to correctly label the RDT resistors. (page 7) Figure 9 added to clearly define the startup characteristics. (page 9) The paragraphs of the Functional Description Overview describing the turn-on sequence is replaced by 3 paragraphs to more clearly describe the under voltage and turn-on and turn-off characteristics. (page 9) A new section is added to the application information describing how the drivers outputs can be paralleled. (pages 1..12) Various minor corrections to text for grammar and spelling. M8.15D POD on page 14 - Converted to new POD format. Removed table of dimensions and moved dimensions onto drawing. Added land pattern.
January 14, 2011	FN7720.0	Initial Release

Products

Intersil Corporation is a leader in the design and manufacture of high-performance analog semiconductors. The Company's products address some of the industry's fastest growing markets, such as, flat panel displays, cell phones, handheld products, and notebooks. Intersil's product families address power management and analog signal processing functions. Go to www.intersil.com/products for a complete list of Intersil product families.

For a complete listing of Applications, Related Documentation and Related Parts, please see the respective device information page on intersil.com: [ISL89166](#), [ISL89167](#), [ISL89168](#).

To report errors or suggestions for this datasheet, please go to www.intersil.com/askourstaff

FITs are available from our website at <http://rel.intersil.com/reports/search.php>

For additional products, see www.intersil.com/product_tree

Intersil products are manufactured, assembled and tested utilizing ISO9000 quality systems as noted in the quality certifications found at www.intersil.com/design/quality

Intersil products are sold by description only. Intersil Corporation reserves the right to make changes in circuit design, software and/or specifications at any time without notice. Accordingly, the reader is cautioned to verify that data sheets are current before placing orders. Information furnished by Intersil is believed to be accurate and reliable. However, no responsibility is assumed by Intersil or its subsidiaries for its use; nor for any infringements of patents or other rights of third parties which may result from its use. No license is granted by implication or otherwise under any patent or patent rights of Intersil or its subsidiaries.

For information regarding Intersil Corporation and its products, see www.intersil.com

ISL89166, ISL89167, ISL89168

Package Outline Drawing L8.3x3I

8 LEAD THIN DUAL FLAT NO-LEAD PLASTIC PACKAGE
Rev 1 6/09

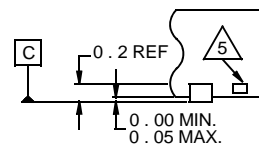
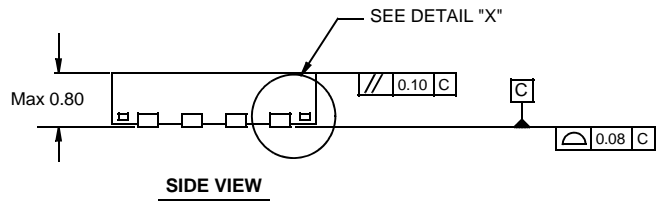
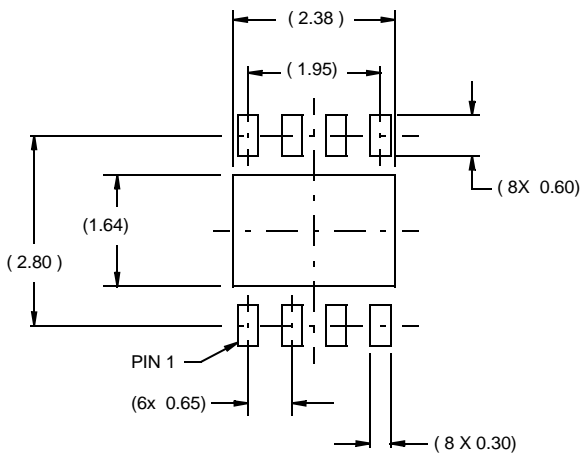
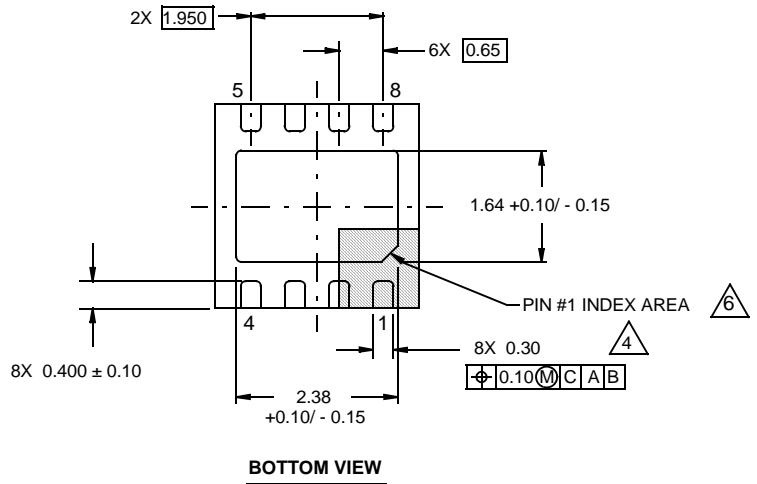
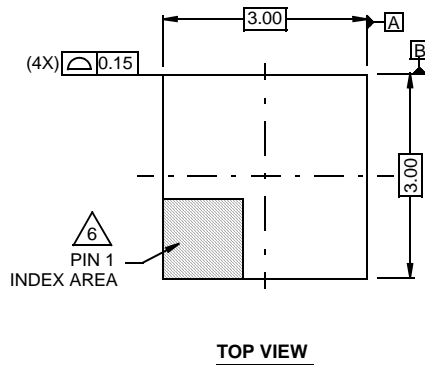

NOTES:

1. Dimensions are in millimeters.
Dimensions in () for Reference Only.
2. Dimensioning and tolerancing conform to AMSE Y14.5m-1994.
3. Unless otherwise specified, tolerance : Decimal ± 0.05
4. Dimension applies to the metallized terminal and is measured between 0.15mm and 0.30mm from the terminal tip.
5. Tiebar shown (if present) is a non-functional feature.
6. The configuration of the pin #1 identifier is optional, but must be located within the zone indicated. The pin #1 identifier may be either a mold or mark feature.

Package Outline Drawing

M8.15D

8 LEAD NARROW BODY SMALL OUTLINE EXPOSED PAD PLASTIC PACKAGE

Rev 1, 3/11

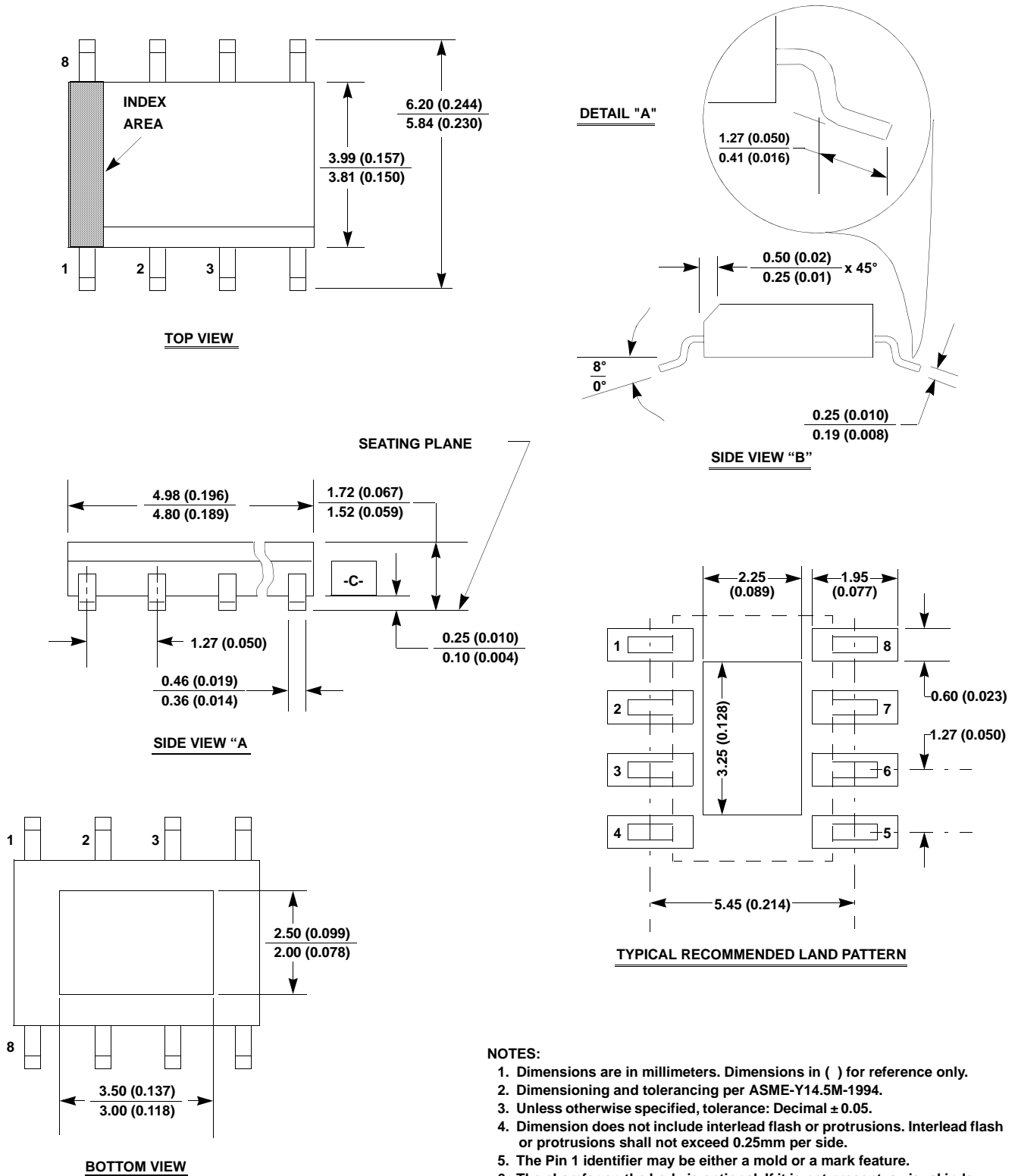

NOTES:

1. Dimensions are in millimeters. Dimensions in () for reference only.
2. Dimensioning and tolerancing per ASME-Y14.5M-1994.
3. Unless otherwise specified, tolerance: Decimal ± 0.05.
4. Dimension does not include interlead flash or protrusions. Interlead flash or protrusions shall not exceed 0.25mm per side.
5. The Pin 1 identifier may be either a mold or a mark feature.
6. The chamfer on the body is optional. If it is not present, a visual index feature must be located within the crosshatched area.