

# Complete Current Share 10A DC/DC Power Module

## ISL8200AMM

The ISL8200AMMREP is a simple and easy to use high power, current-sharing DC/DC power module for Datacom/Telecom/FPGA power hungry applications. All that is needed is the ISL8200AMMREP, a few passive components and one  $V_{OUT}$  setting resistor to have a complete 10A design ready for market.

The ease of use virtually eliminates the design and manufacturing risks while dramatically improving time to market.

Need more output current? Parallel up to six ISL8200AMMREP modules to scale up to a 60A solution (see Figure 6 on page 10).

The simplicity of the ISL8200AMMREP is in its "Off The Shelf", unassisted implementation versus a discrete implementation. Patented current sharing in multi-phase operation greatly reduces ripple currents, BOM cost and complexity. For example, parallel 2 for 20A and up to 6 for 60A. The output voltage can be precisely regulated to as low as 0.6V with  $\pm 1\%$  output voltage regulation over line, load, and temperature variations.

The ISL8200AMMREP's thermally enhanced, compact QFN package, operates at full load and over-temperature, without requiring forced air cooling. It's so thin it can even fit on the back side of the PCB. Easy access to all pins with few external components, reduces the PCB design to a component layer and a simple ground layer.

## Features

- Specifications per DLA VID V62/10608
- Complete Switch Mode Power Supply in One Package
- Patented Current Share Architecture Reduces Layout Sensitivity when Modules are Paralleled
- Programmable Phase Shift (1 to 6 Phase)
- Extremely Low Profile (2.2mm Height)
- Input Voltage Range +3.0V to +20V at 10A, Current Share up to 60A
- A Single Resistor Sets  $V_{OUT}$  from +0.6V to +6V
- Output Overvoltage, Overcurrent and Over-Temperature Protection and Undervoltage Indication
- Full Mil-Temp Electrical Performance from -55°C to +125°C
- Full Traceability Through Assembly and Test byDate/Trace Code Assignment
- Enhanced Process Change Notification
- Enhanced Obsolescence Management

## Applications

- Servers, Telecom and Datacom Applications
- Industrial and Medical Equipment
- Point of Load Regulation

## Related Literature

- [AN1738](#) "ISL8200AMEV1PHZ Evaluation Board User's Guide"
- [ISL8200AMMREP iSim Model](#) - (Product Information Page)

## Complete Functional Schematic

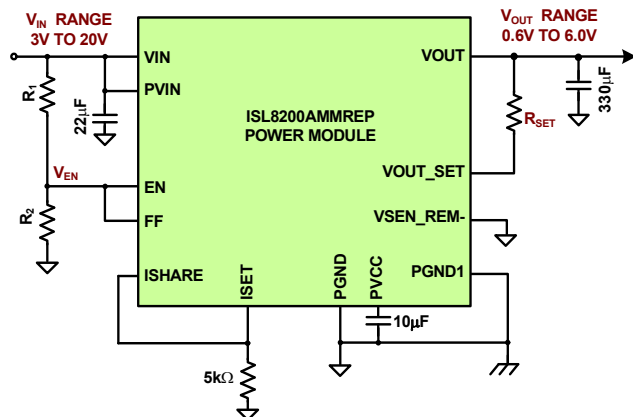

FIGURE 1. COMPLETE 10A DESIGN, JUST SELECT  $R_{SET}$  FOR THE DESIRED  $V_{OUT}$

## ISL8200AMMREP Package

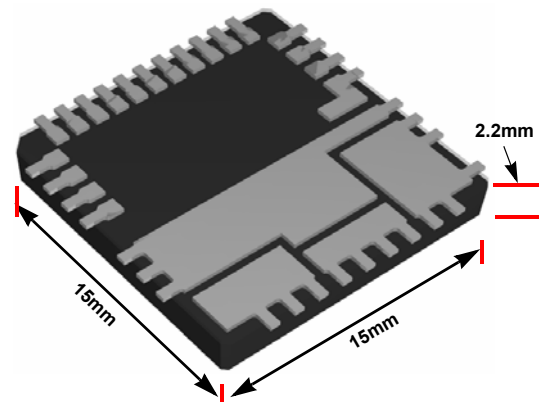

FIGURE 2. THE 2.2mm HEIGHT IS IDEAL FOR THE BACKSIDE OF PCBs WHEN SPACE AND HEIGHT IS A PREMIUM

# ISL8200AMM

## Ordering Information

PART NUMBER (Notes 1, 2)	VENDOR ITEM DRAWING	PART MARKING	TEMP. RANGE (°C)	PACKAGE	PKG. DWG. #
ISL8200AMMREP	V62/10608-02XB	ISL8200AMMREP	-55 °C to +125 °C	23 Ld QFN	L23.15x15

### NOTES:

1. Add "-T" suffix for tape and reel. Please refer to [TB347](#) for details on reel specifications.
2. For Moisture Sensitivity Level (MSL), please see device information page for [ISL8200AMM](#). For more information on MSL please see techbrief [TB363](#).

## Pinout Internal Circuit

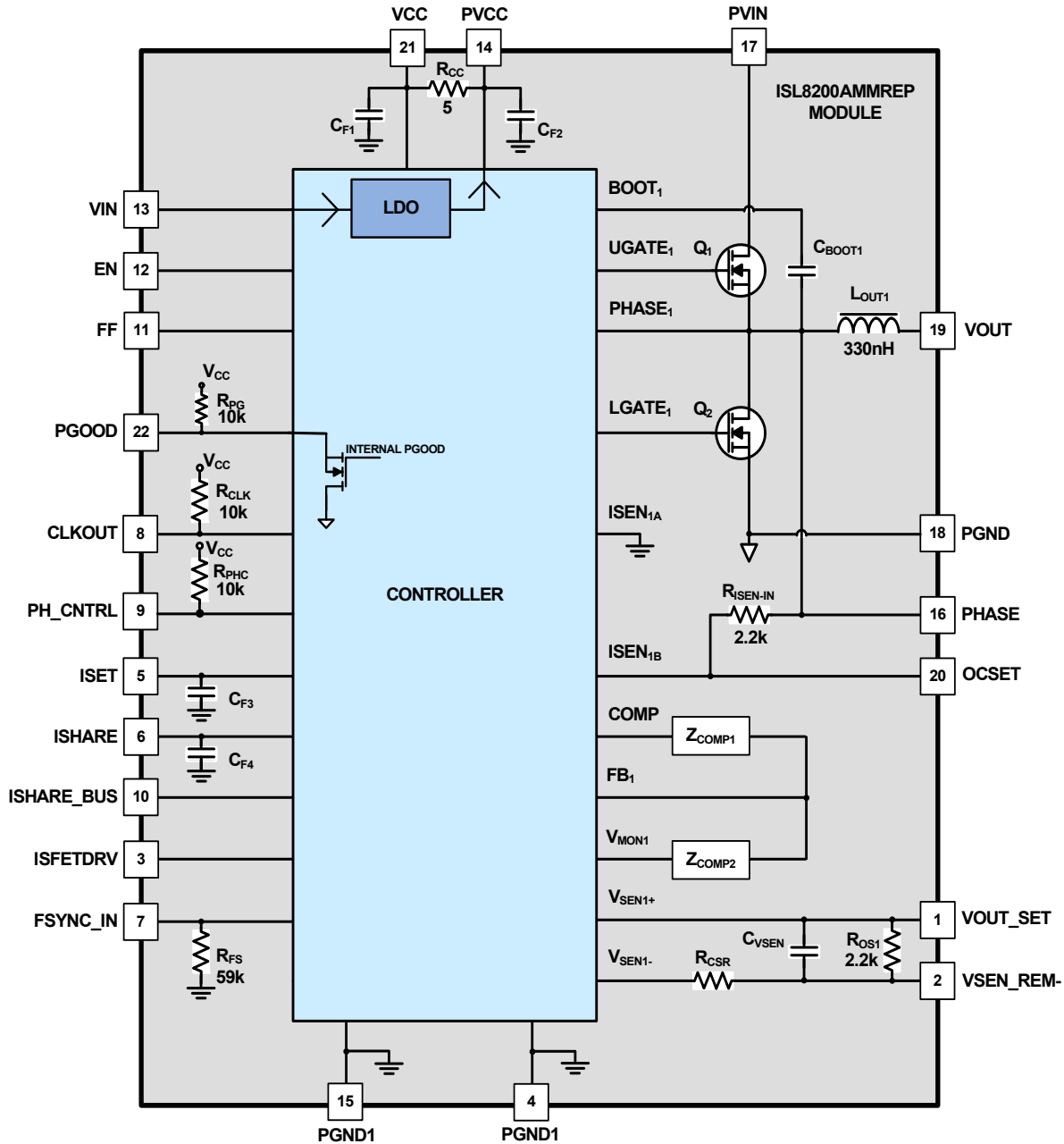

# ISL8200AMM

## Pin Configuration

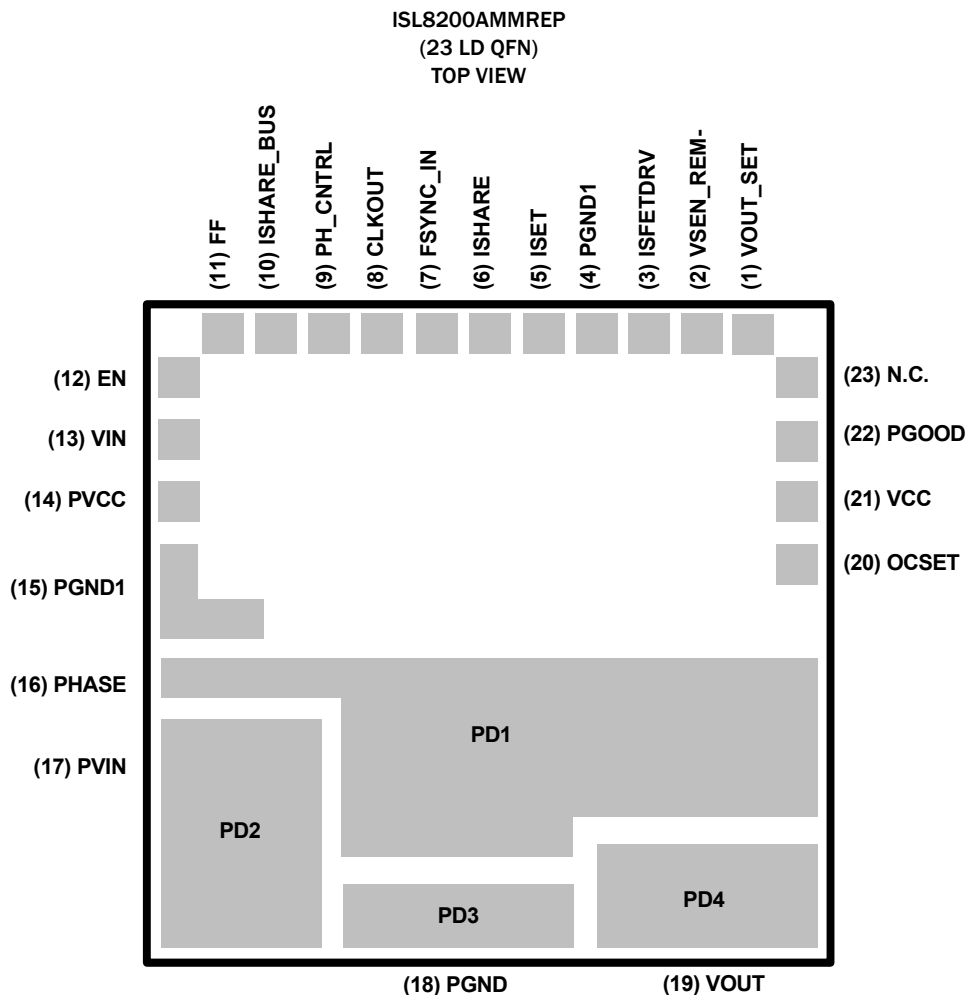

## Pin Descriptions

PIN #	PIN NAME	PIN DESCRIPTION
1	VOUT_SET	Analog Voltage Input - Used with $V_{OUT}$ to program the regulator output voltage. The typical input impedance of VOUT_SET with respect to VSEN_REM- is 500k $\Omega$ . The voltage input typ. is 0.6V.
2	VSEN_REM-	Analog Voltage Input - This pin is the negative input of standard unity gain operational amplifier for differential remote sense for the regulator, and should connect to the negative rail of the load/processor. This pin can be used for $V_{OUT}$ trimming by connecting a resistor from this pin to the VOUT_SET pin.
3	ISFETDRV	Digital Output - This pin is used to drive an optional NFET, which will connect ISHARE with the system ISHARE bus upon completing a pre-bias startup. The voltage output range is 0V to 5V.
4, 15	PGND1	Normal Ground - All voltage levels are referenced to this pad. This pad provides a return path for the low side MOSFET drives and internal power circuitries as well as all analog signals. PGND and PGND1 should be connected together with a ground plane.
5	ISET	Analog Current Output - This pin sources a 15 $\mu$ A offset current plus Channel 1's average current. The voltage (VISET) set by an external resistor (RISET) represents the average current level of the local active module. For full-scale current, RISET should be ~10k $\Omega$ . The output current range is 15 $\mu$ A to 126 $\mu$ A typ. The ISET and ISHARE pins are used for current sharing purposes with multiple ISL8200AMMREP modules. In the single module configuration, this pin can be tied to the ISHARE pin. In multi-phase operation, if noise is a concern, add an additional 10pF capacitor to the ISET line.

# ISL8200AMM

## Pin Descriptions (Continued)

PIN #	PIN NAME	PIN DESCRIPTION
6	ISHARE	Analog Current Output - Cascaded system level overcurrent shutdown pin. This pin is used where you have multiple modules configured for current sharing and is used with a common current share bus. The bus sums each of the modules' average current contribution to the load to protect for an overcurrent condition at the load. The pin sources 15 $\mu$ A plus average module's output current. The shared bus voltage ( $V_{ISHARE}$ ) is developed across an external resistor ( $R_{ISHARE}$ ). $V_{ISHARE}$ represents the average current of all active channel(s) that are connected together. The ISHARE bus voltage is compared with each module's internal reference voltage set by each module's $R_{ISET}$ resistor. This will generate an individual current share error signal in each cascaded controller. The share bus impedance $R_{ISHARE}$ should be set as $R_{ISET}/NCTRL$ , $R_{ISET}$ divided by the number of active current sharing controllers. The output current from this pin generates a voltage across the external resistor. This voltage, $V_{ISHARE}$ , is compared to an internal 1.2V threshold for average overcurrent protection. For full-scale current, $R_{ISHARE}$ should be $\sim 10k\Omega$ . Typically 10k $\Omega$ is used for $R_{SHARE}$ and $R_{SET}$ . The output current range is 15 $\mu$ A to 126 $\mu$ A typ.
7	FSYNC_IN	Analog Input Control Pin - An optional external resistor (RFS-ext) connected to this pin and ground will increase the oscillator switching frequency. It has an internal 59k $\Omega$ resistor for a default frequency of 700kHz. The internal oscillator will lock to an external frequency source when connected to a square waveform. The external source is typically the CLKOUT signal from another ISL8200AMMREP or an external clock. The internal oscillator synchronizes with the leading positive edge of the input signal. The input voltage range for the external source is 0V to 5V Square Wave. When not synchronized to an external clock, a 100pF capacitor between FSYNC_IN and PGND1 is recommended.
8	CLKOUT	Digital Voltage Output - This pin provides a clock signal to synchronize with other ISL8200AMMREP(s). When there is more than one ISL8200AMMREP in the system, the two independent regulators can be programmed via PH_CNTRL for different degrees of phase delay.
9	PH_CNTRL	Analog Input - The voltage level on this pin is used to program the phase shift of the CLKOUT clock signal to synchronize with other module(s).
10	ISHARE_BUS	Open pin until first PWM pulse is generated. Then, via an internal FET, this pin connects the module's ISHARE to the system's ISHARE bus after pre-bias is complete and soft-start is initiated.
11	FF	Analog Voltage Input - The voltage on this pin is fed into the controller, adjusting the sawtooth amplitude to generate the feed-forward function. The input voltage range is 0.8 to $V_{CC}$ . Typically, FF is connected to EN.
12	EN	This is a double function pin: Analog Input Voltage - The input voltage to this pin is compared with a precision 0.8V reference and enables the digital soft-start. The input voltage range is 0V to $V_{CC}$ or $V_{IN}$ through a pull-up resistor maintaining a typical current of 5mA. Analog Voltage Output - This pin can be used as a voltage monitor for input bus undervoltage lockout. The hysteresis levels of the lockout can be programmed via this pin using a resistor divider network. Furthermore, during fault conditions (such as overvoltage, overcurrent, and over-temperature), this pin is used to communicate the information to other cascaded modules by pulling the wired OR low as it is an Open Drain. The output voltage range is 0V to $V_{CC}$ .
13	VIN	Analog Voltage Input - This pin should be tied directly to the input rail when using the internal linear regulator. It provides power to the internal linear drive circuitry. When used with an external 5V supply, this pin should be tied directly to PVCC. The internal linear device is protected against the reversed bias generated by the remaining charge of the decoupling capacitor at $V_{CC}$ when losing the input rail. The input voltage range is 4.5V to 20V.
14	PVCC	Analog Output - This pin is the output of the internal series linear regulator. It provides the bias for both low-side and high-side drives. Its operational voltage range is 4.5V to 5.6V. The decoupling ceramic capacitor in the PVCC pin is 10 $\mu$ F.
16	PHASE	Analog Output - This pin is the phase node of the regulator. The output voltage range is 0V to 30V.
17	PVIN	Analog Input - This input voltage is applied to the power FETs with the FET's ground being the PGND pin. It is recommended to place input decoupling capacitance, 22 $\mu$ F, directly between the PVIN pin and the PGND pin as close as possible to the module. The input voltage range is 3V to 20V.
18	PGND	All voltage levels are referenced to this pad. This is the low side MOSFET ground. PGND and PGND1 should be connected together with a ground plane.
19	VOUT	Output voltage from the module. The output voltage range is 0.6V to 6V.
20	OCSET	Analog Input - This pin is used with the PHASE pin to set the current limit of the module. The input voltage range is 0V to 30V.
21	VCC	Analog Input - This pin provides bias power for the analog circuitry. It's operational range is 4.5V to 5.6V. In 3.3V applications, $V_{CC}$ , PVCC and VIN should be shorted to allow operation at the low end input as it relates to the $V_{CC}$ falling threshold limit. This pin can be powered either by the internal linear regulator or by an external voltage source.
22	PGOOD	Analog Output - This pin, pulled up to $V_{CC}$ via an internal 10k $\Omega$ resistor, provides a Power Good signal when the output is within 9% of nominal output regulation point with 4% hysteresis (13%/9%), and soft-start is complete. An external pull-up is not required. PGOOD monitors the outputs (VMON1) of the internal differential amplifiers. The output voltage range is 0V to $V_{CC}$ .

# ISL8200AMM

## Pin Descriptions (Continued)

PIN #	PIN NAME	PIN DESCRIPTION
23	NC	Not internal connected
PD1	Phase Thermal Pad	Used for both the PHASE pin (Pin # 16) and for heat removal connecting to heat dissipation layers using vias. Connect this pad to a copper island on the PCB board with the same shape as the pad; this is electrically connected to PHASE pin 16.
PD2	PVIN Thermal Pad	Used for both the PVIN pin (Pin # 17) and for heat removal connecting to heat dissipation layers using vias. Connect this pad to a copper island on the PCB board with the same shape as the pad; this is electrically connected to PVIN pin 17.
PD3	PGND Thermal Pad	Used for both the PGND pin (Pin # 18) and for heat removal connecting to heat dissipation layers using vias. Connect this pad to a copper island on the PCB board with the same shape as the pad; this is electrically connected to PGND pin 18.
PD4	VO <sub>UT</sub> Thermal Pad	Used for both the VOUT pin (Pin # 19) and for heat removal connecting to heat dissipation layers using vias. Connect this pad to a copper island on the PCB board with the same shape as the pad; this is electrically connected to VOUT pin 19.

## Typical Application Circuits

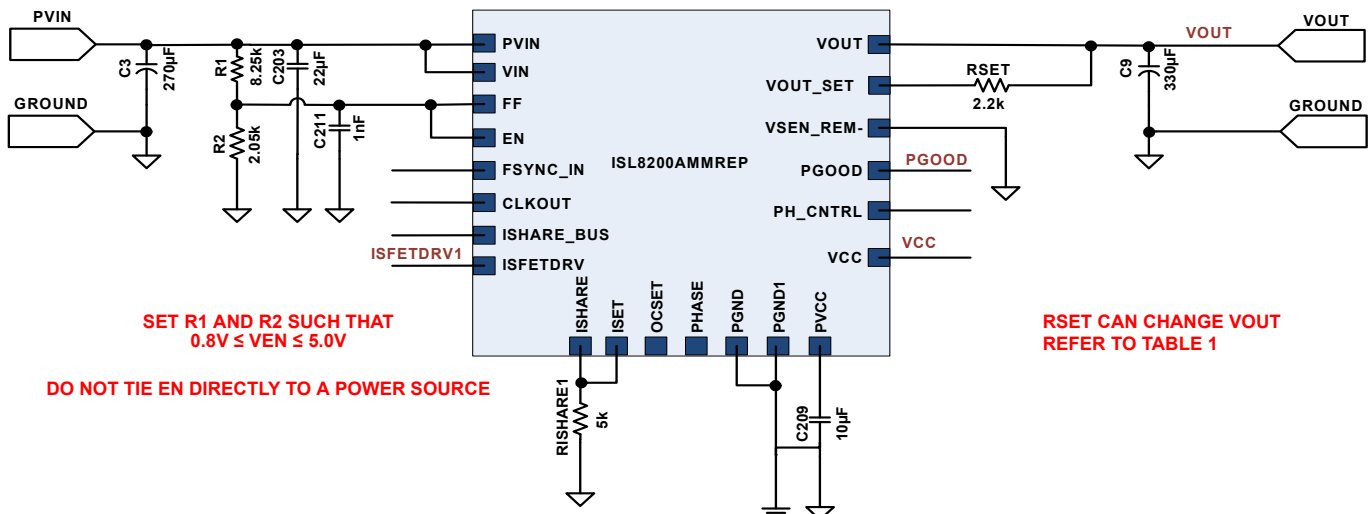

FIGURE 3. SINGLE PHASE 10A 1.2V OUTPUT CIRCUIT

# Typical Application Circuits (continued)

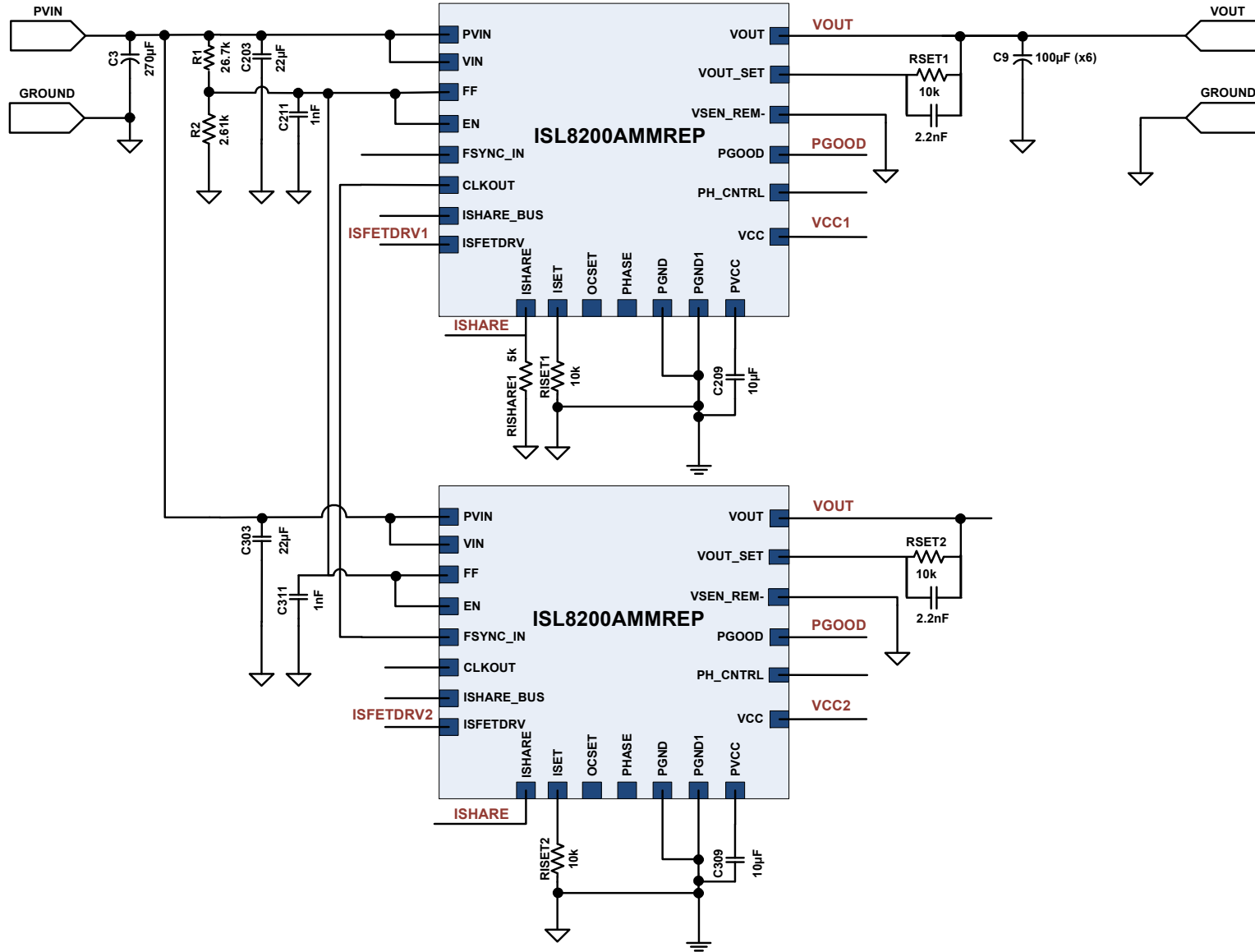

FIGURE 4. TWO PHASE 20A 3.3V OUTPUT CIRCUIT

# ISL8200AMM

## Absolute Maximum Ratings

Input Voltage, $V_{IN}$	-0.3V to +27V
Driver Bias Voltage, $PV_{CC}$	-0.3V to +6.0V
Signal Bias Voltage, $V_{CC}$	-0.3V to +6.5V
BOOT/UGATE Voltage, $V_{BOOT}$	-0.3V to +36V
Phase Voltage, $V_{PHASE}$	$V_{BOOT} - 7V$ to $V_{BOOT} + 0.3V$
BOOT to PHASE Voltage,	
$V_{BOOT} - V_{PHASE}$	-0.3V to $V_{CC} + 0.3V$
Input, Output or I/O Voltage	-0.3V to $V_{CC} + 0.3V$
ESD Rating	
Human Body Model (Tested per JESD22-A114E)	2kV
Machine Model (Tested per JESD22-A115-A)	200V
Charge Device Model (Tested per JESD22-C101C)	1kV
Latch Up (Tested per JESD-78B; Class 2, Level A)	100mA

## Thermal Information

Thermal Resistance (Typical)	$\theta_{JA}$ ( $^{\circ}C/W$ )	$\theta_{JC}$ ( $^{\circ}C/W$ )
QFN Package (Notes 3, 4)	13	2.0
Maximum Storage Temperature Range	-55 $^{\circ}C$ to +150 $^{\circ}C$	

## Recommended Operating Conditions

Input Voltage, $PV_{IN}$ , $V_{IN}$	3V to 20V
Driver Bias Voltage, $PV_{CC}$	4.5V to 5.6V
Signal Bias Voltage, $V_{CC}$	4.5V to 5.6V
Boot to Phase Voltage	
$V_{BOOT} - V_{PHASE}$	<6V
Ambient Temperature Range	-55 $^{\circ}C$ to +125 $^{\circ}C$
Junction Temperature Range	-55 $^{\circ}C$ to +125 $^{\circ}C$

**CAUTION:** Do not operate at or near the maximum ratings listed for extended periods of time. Exposure to such conditions may adversely impact product reliability and result in failures not covered by warranty.

### NOTES:

- $\theta_{JA}$  is measured in free air with the component mounted on a high effective thermal conductivity test board (i.e., 4-layer type without thermal vias - see tech brief [TB379](#)) per JEDEC standards except that the top and bottom layers assume solid plains.
- For  $\theta_{JC}$ , the "case temp" location is the center of the exposed metal pad on the package underside.

## Electrical Specifications **Boldface limits apply over the operating temperature range, -55 $^{\circ}C$ to +125 $^{\circ}C$ .**

PARAMETER	SYMBOL	TEST CONDITIONS	MIN (Note 6)	TYP (Note 5)	MAX (Note 6)	UNITS
<b><math>V_{CC}</math> SUPPLY CURRENT</b>						
Nominal Supply $V_{IN}$ Current	$I_{Q\_VIN}$	$PV_{IN} = V_{IN} = 20V$ ; No Load; $F_{SW} = 700kHz$		36		mA
Nominal Supply $V_{IN}$ Current	$I_{Q\_VIN}$	$PV_{IN} = V_{IN} = 4.5V$ ; No Load; $F_{SW} = 700kHz$		27		mA
Shutdown Supply $V_{CC}$ Current	$I_{VCC}$	$EN = 0V$ , $V_{CC} = 2.97V$		9		mA
<b>INTERNAL LINEAR REGULATOR</b>						
Maximum Current	$I_{PVCC}$	$PV_{CC} = 4V$ to 5.6V		320		mA
Saturated Equivalent Impedance	$R_{LDO}$	P-Channel MOSFET ( $V_{IN} = 5V$ )		1		$\Omega$
<b>POWER-ON RESET</b>						
Rising $V_{CC}$ Threshold				2.85	(Note 7)	V
Falling $V_{CC}$ Threshold				2.65	(Note 7)	V
Rising $PV_{CC}$ Threshold				2.85	(Note 7)	V
Falling $PV_{CC}$ Threshold				2.65	(Note 7)	V
System Soft-start Delay	$t_{SS\_DLY}$	After PLL, $V_{CC}$ , and $PV_{CC}$ PORs, and EN above their thresholds		384		Cycles
<b>ENABLE</b>						
Turn-On Threshold Voltage			(Note 7)	0.8	(Note 7)	V
Hysteresis Sink Current	$I_{EN\_HYS}$		(Note 7)	30	(Note 7)	$\mu A$
Undervoltage Lockout Hysteresis	$V_{EN\_HYS}$	$V_{EN\_RTH} = 10.6V$ ; $V_{EN\_FTH} = 9V$ $R_{UP} = 53.6k\Omega$ , $R_{DOWN} = 5.23k\Omega$		1.6		V
Sink Current	$I_{EN\_SINK}$	$V_{EN} = 1V$	(Note 7)			mA
Sink Impedance	$R_{EN\_SINK}$	$V_{EN} = 1V$			(Note 7)	$\Omega$
<b>OSCILLATOR</b>						
Oscillator Frequency	FOSC	$R_{FS} = 59k\Omega$ ; Figure 34		700		kHz
Total Variation		$V_{CC} = 5V$ ;	(Note 7)		(Note 7)	%
<b>FREQUENCY SYNCHRONIZATION AND PHASE LOCK LOOP (Note 7)</b>						
Synchronization Frequency		$V_{CC} = 5.4V$	FOSC		(Note 7)	kHz

# ISL8200AMM

## Electrical Specifications **Boldface limits apply over the operating temperature range, -55°C to +125°C. (Continued)**

PARAMETER	SYMBOL	TEST CONDITIONS	MIN (Note 6)	TYP (Note 5)	MAX (Note 6)	UNITS
Input Signal Duty Cycle Range			(Note 7)		(Note 7)	%
<b>PWM</b>						
Minimum PWM OFF Time	$t_{\text{MIN\_OFF}}$		(Note 7)	345	(Note 7)	ns
Current Sampling Blanking Time	$t_{\text{BLANKING}}$			175		ns
<b>OUTPUT CHARACTERISTICS</b>						
Output Continuous Current Range	$I_{\text{OUT(DC)}}$	$PV_{\text{IN}} = V_{\text{IN}} = 12\text{V}, V_{\text{OUT}} = 1.2\text{V}$	0		10	A
Line Regulation Accuracy	$\Delta V_{\text{OUT}}/\Delta V_{\text{IN}}$	$V_{\text{OUT}} = 1.2\text{V}, I_{\text{OUT}} = 0\text{A}, PV_{\text{IN}} = V_{\text{IN}} = 3.5\text{V to } 20\text{V}$		0.15		%
		$V_{\text{OUT}} = 1.2\text{V}, I_{\text{OUT}} = 10\text{A}, PV_{\text{IN}} = V_{\text{IN}} = 5\text{V to } 20\text{V}$		0.15		%
Load Regulation Accuracy	$\Delta V_{\text{OUT}}/\Delta I_{\text{OUT}}$	$I_{\text{OUT}} = 0\text{A to } 10\text{A}, V_{\text{OUT}} = 1.2\text{V}, PV_{\text{IN}} = V_{\text{IN}} = 12\text{V}$		0.1		%
Output Ripple Voltage	$\Delta V_{\text{OUT}}$	$I_{\text{OUT}} = 10\text{A}, V_{\text{OUT}} = 1.2\text{V}, PV_{\text{IN}} = V_{\text{IN}} = 12\text{V}$		27		mV <sub>P-P</sub>
		$I_{\text{OUT}} = 0\text{A}, V_{\text{OUT}} = 1.2\text{V}, PV_{\text{IN}} = V_{\text{IN}} = 12\text{V}$		19		mV <sub>P-P</sub>
<b>DYNAMIC CHARACTERISTICS</b>						
Voltage Change For Positive Load Step	$\Delta V_{\text{OUT-DP}}$	$I_{\text{OUT}} = 0\text{A to } 5\text{A}$ . Current slew rate = 2.5A/ $\mu\text{s}$ , $PV_{\text{IN}} = V_{\text{IN}} = 12\text{V}, V_{\text{OUT}} = 1.2\text{V}$		45		mV <sub>P-P</sub>
Voltage Change For Negative Load Step	$\Delta V_{\text{OUT-DN}}$	$I_{\text{OUT}} = 5\text{A to } 0\text{A}$ . Current slew rate = 2.5A/ $\mu\text{s}$ , $PV_{\text{IN}} = V_{\text{IN}} = 12\text{V}, V_{\text{OUT}} = 1.2\text{V}$		55		mV <sub>P-P</sub>
<b>REFERENCE</b>						
Reference Voltage (Include Error and Differential Amplifiers' Offsets)	$V_{\text{REF}}$			0.6		V
			(Note 7)		(Note 7)	%
<b>DIFFERENTIAL AMPLIFIER</b>						
DC Gain	$UG_{\text{DA}}$	Unity Gain Amplifier		0		dB
Unity Gain Bandwidth	$UGBW_{\text{DA}}$			5		MHz
Maximum Source Current for Current Sharing	$I_{\text{VSEN1-}}$	VSEN1- Source Current for Current Sharing when parallel multiple modules each of which has its own voltage loop		350		$\mu\text{A}$
Output Voltage Swing			0		<b><math>V_{\text{CC}} - 1.8</math></b>	V
Disable Threshold	$V_{\text{VSEN-}}$	$V_{\text{MON1}} = \text{Tri-State}$		$V_{\text{CC}} - 0.4$		V
<b>OVERCURRENT PROTECTION</b>						
Channel Overcurrent Limit	$I_{\text{SOURCE}}$	$V_{\text{CC}} = 2.97\text{V to } 5.6\text{V}$		111		$\mu\text{A}$
Channel Overcurrent Limit	$I_{\text{SOURCE}}$	$V_{\text{CC}} = 5\text{V}$ ;	(Note 7)	111	(Note 7)	$\mu\text{A}$
Share Pin OC Threshold	$V_{\text{OC\_ISHARE}}$	Comparator offset included	(Note 7)	1.20	(Note 7)	V
<b>POWER GOOD MONITOR</b>						
Undervoltage Falling Trip Point	$V_{\text{UVF}}$	Percentage Below Reference Point	(Note 7)	-13	(Note 7)	%
Undervoltage Rising Hysteresis	$V_{\text{UVR\_HYS}}$	Percentage Above UV Trip Point		4		%
Overvoltage Rising Trip Point	$V_{\text{OVR}}$	Percentage Above Reference Point	(Note 7)	13	(Note 7)	%
Overvoltage Falling Hysteresis	$V_{\text{OVF\_HYS}}$	Percentage below OV Trip Point		4		%
PGOOD Low Output Voltage		$I_{\text{PGOOD}} = 2\text{mA}$			(Note 7)	V
Sinking Impedance		$I_{\text{PGOOD}} = 2\text{mA}$			(Note 7)	$\Omega$
Maximum Sinking Current		$V_{\text{PGOOD}} < 0.8\text{V}$		10		mA
<b>OVERVOLTAGE PROTECTION</b>						
OV Latching Trip Point		EN = UGATE = LATCH Low, LGATE = High	(Note 7)	120	(Note 7)	%
OV Non-Latching Trip Point		EN = Low, UGATE = Low, LGATE = High		113		%
LGATE Release Trip Point		EN = Low/HIGH, UGATE = Low, LGATE = Low		87		%



# ISL8200AMM

## Electrical Specifications **Boldface limits apply over the operating temperature range, -55°C to +125°C. (Continued)**

PARAMETER	SYMBOL	TEST CONDITIONS	MIN (Note 6)	TYP (Note 5)	MAX (Note 6)	UNITS
<b>OVER-TEMPERATURE PROTECTION CONTROLLER JUNCTION TEMPERATURE</b>						
Over-Temperature Trip				150		°C
Over-Temperature Release Threshold				125		°C
<b>INTERNAL COMPONENT VALUES</b>						
Internal Resistor Between PVCC and VCC pin	$R_{CC}$			5		$\Omega$
Internal Resistor Between PHASE and OCSET Pins	$R_{ISEN-IN}$			2.2		k $\Omega$
Internal Resistor Between FSYNC_IN and PGND1 Pins	$R_{FS}$			59		k $\Omega$
Internal Resistor Between PGOOD and VCC Pins	$R_{PG}$			10		k $\Omega$
Internal Resistor Between CLKOUT and VCC Pins	$R_{CLK}$			10		k $\Omega$
Internal Resistor Between PH_CNTRL and VCC Pins	$R_{PHC}$			10		k $\Omega$
Internal Resistor Between VOUT_SET and VSEN_REM- pin	$R_{OS1}$			2.2		k $\Omega$

### NOTES:

- Parameters with TYP limits are not production tested, unless otherwise specified.
- Parameters with MIN and/or MAX limits are 100% tested for internal IC prior to module assembly, unless otherwise specified. Temperature limits established by characterization and are not production tested.
- Refer to Defense Logistics Agency (DLA) drawing number V62/10608-02XB for min/max parameters.

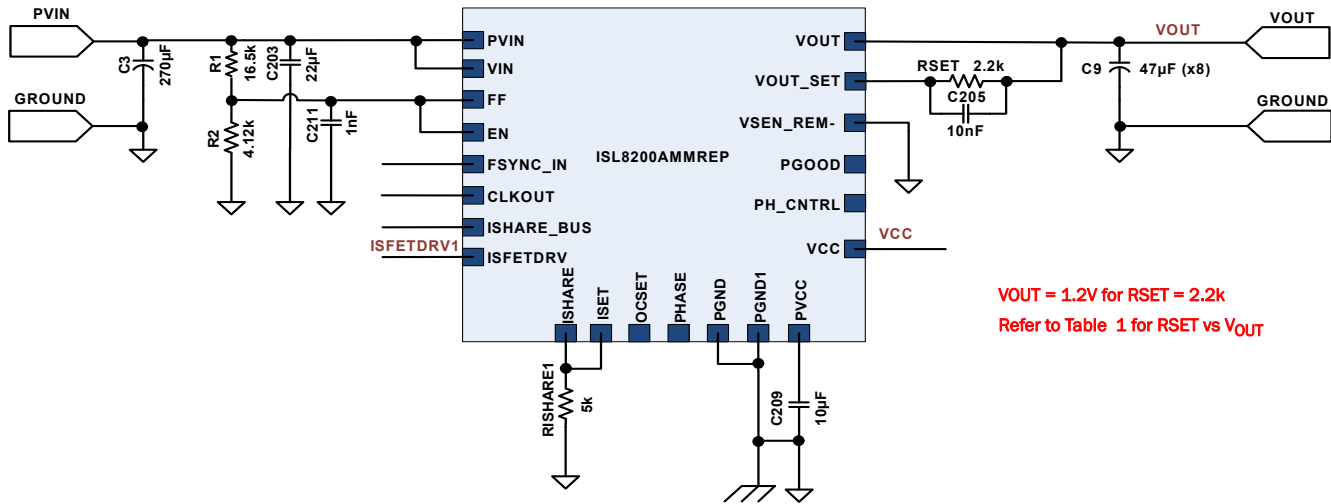

FIGURE 5. TEST CIRCUIT FOR ALL PERFORMANCE AND DERATING GRAPHS

## Typical Performance Characteristics

**Efficiency Performance**  $T_A = +25^\circ\text{C}$ ,  $PV_{IN} = V_{IN}$ ,  $C_{IN} = 220\mu\text{F} \times 1$ ,  $10\mu\text{F}/\text{Ceramic} \times 2$ ,  $C_{OUT} = 47\mu\text{F}/\text{Ceramic} \times 8$ .

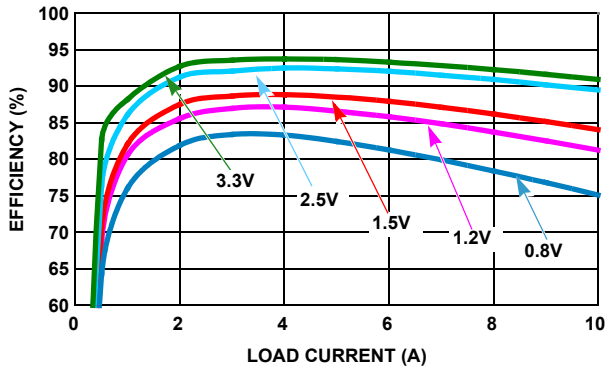

FIGURE 6. EFFICIENCY vs LOAD CURRENT ( $5V_{IN}$ )

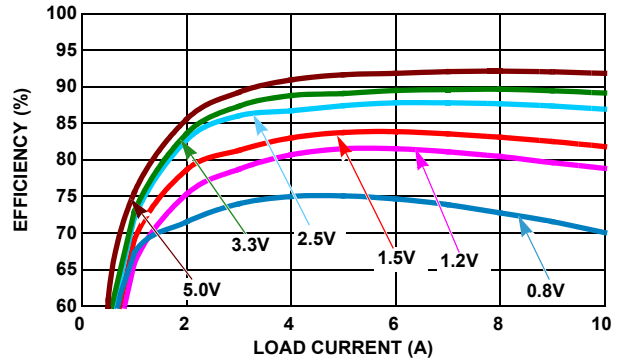

FIGURE 7. EFFICIENCY vs LOAD CURRENT ( $12V_{IN}$ )

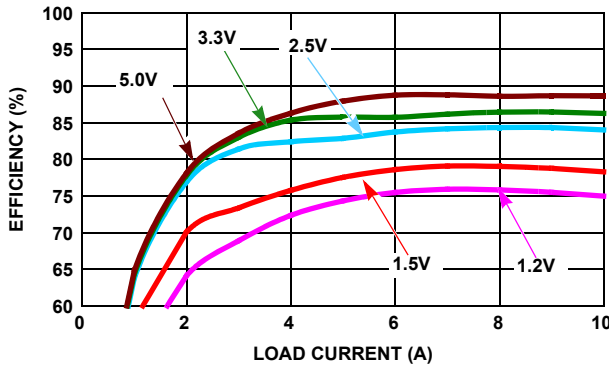

FIGURE 8. EFFICIENCY vs LOAD CURRENT ( $20V_{IN}$ )

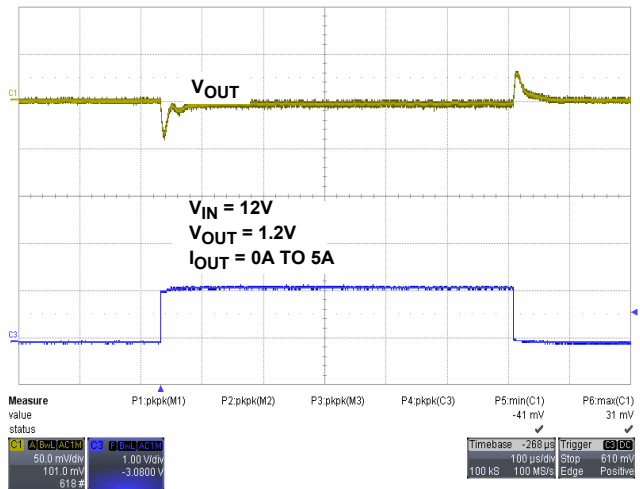

FIGURE 9. 1.2V TRANSIENT RESPONSE

## Typical Performance Characteristics (Continued)

**Transient Response Performance**  $T_A = +25^\circ\text{C}$ ,  $PV_{IN} = V_{IN} = 12\text{V}$ ,  $C_{IN} = 220\mu\text{F} \times 1$ ,  $10\mu\text{F}/\text{Ceramic} \times 2$ ,  $C_{OUT} = 47\mu\text{F}/\text{Ceramic} \times 8$ ,  $I_{OUT} = 0\text{A TO } 5\text{A}$ , Current slew rate =  $2.5\text{A}/\mu\text{s}$

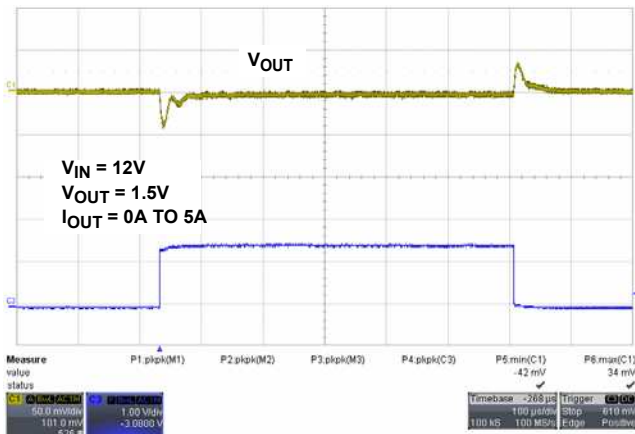

FIGURE 10. 1.5V TRANSIENT RESPONSE

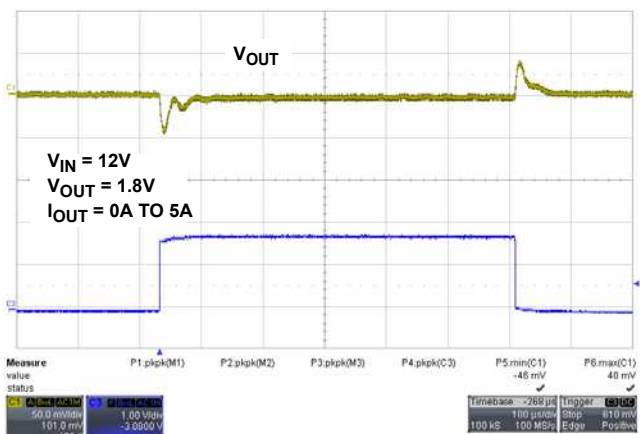

FIGURE 11. 1.8V TRANSIENT RESPONSE

## Typical Performance Characteristics (Continued)

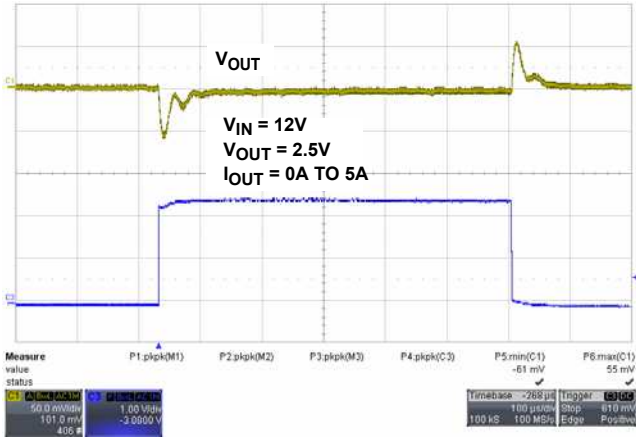

FIGURE 12. 2.5V TRANSIENT RESPONSE

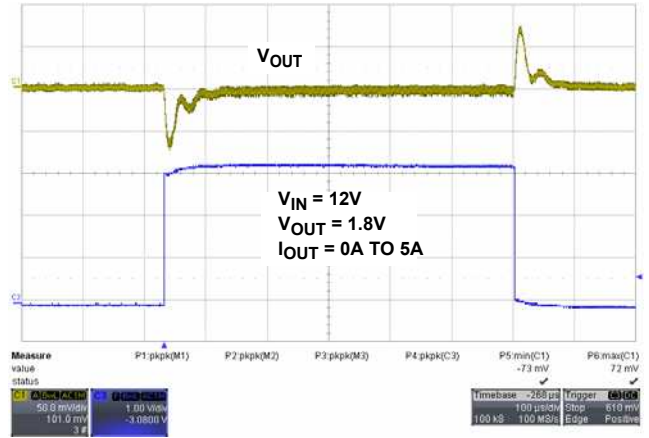

FIGURE 13. 3.3V TRANSIENT RESPONSE

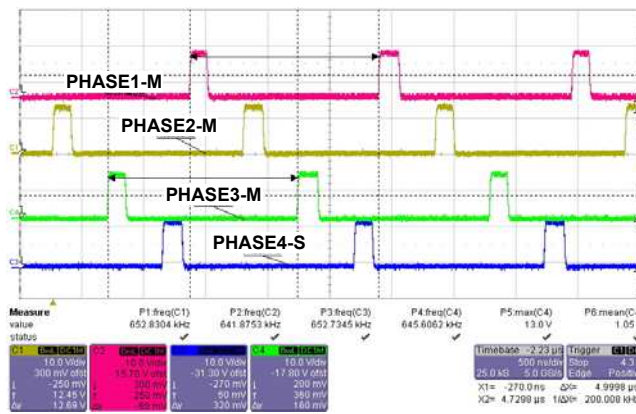

FIGURE 14. FOUR MODULE CLOCK SYNC (V<sub>IN</sub> = 12V)

## Typical Performance Characteristics (Continued)

**Output Ripple Performance**  $T_A = +25^\circ\text{C}$ ,  $PV_{IN} = V_{IN} = 12\text{V}$ ,  $C_{IN} = 220\mu\text{F} \times 1$ ,  $10\mu\text{F}/\text{Ceramic} \times 2$ ,  
 $C_{OUT} = 100\mu\text{F}/\text{Ceramic} \times 6$   $I_{OUT} = \text{No Load, 5, 10A}$

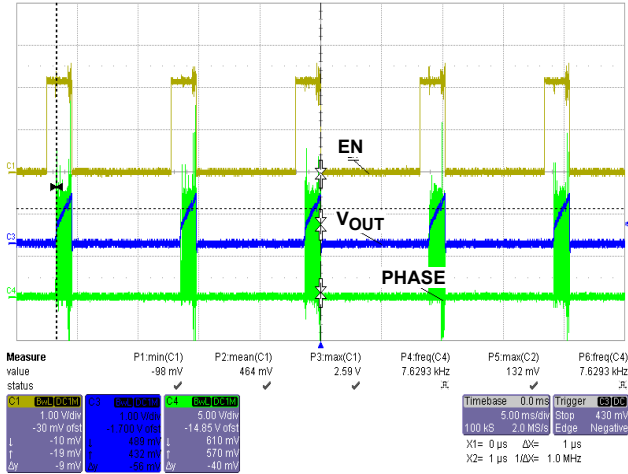

FIGURE 15. OVERCURRENT PROTECTION

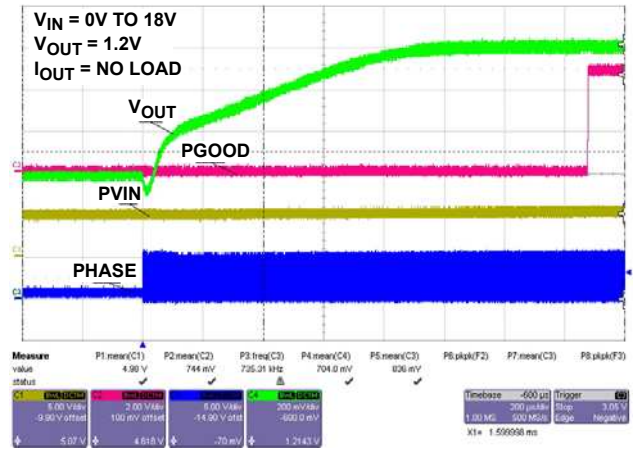

FIGURE 16. 50% PRE-BIAS START UP

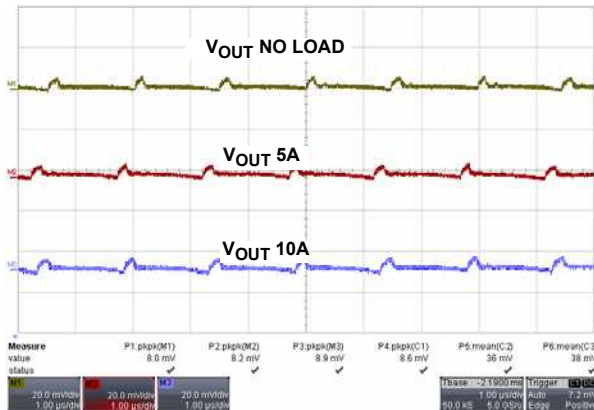

FIGURE 17. 1.2V OUTPUT RIPPLE

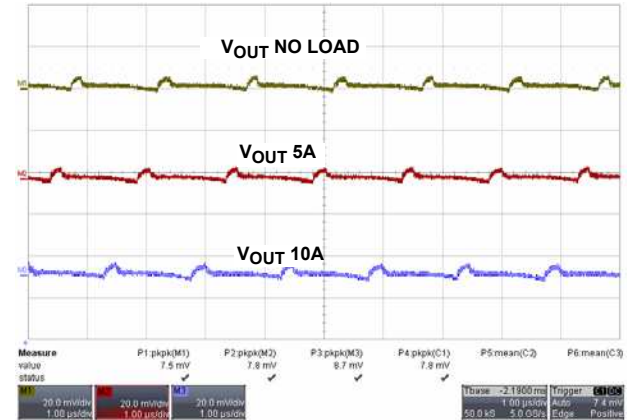

FIGURE 18. 1.5V OUTPUT RIPPLE

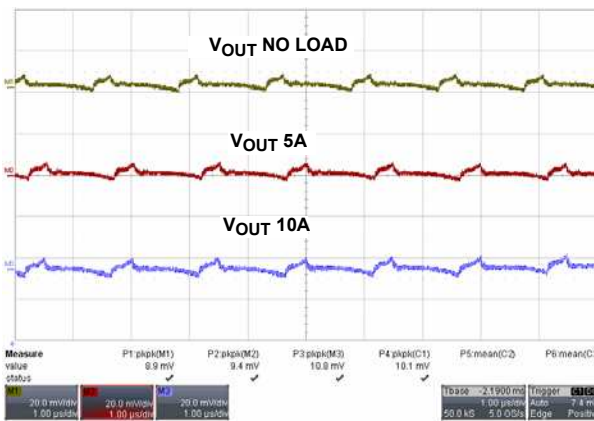

FIGURE 19. 2.5V OUTPUT RIPPLE

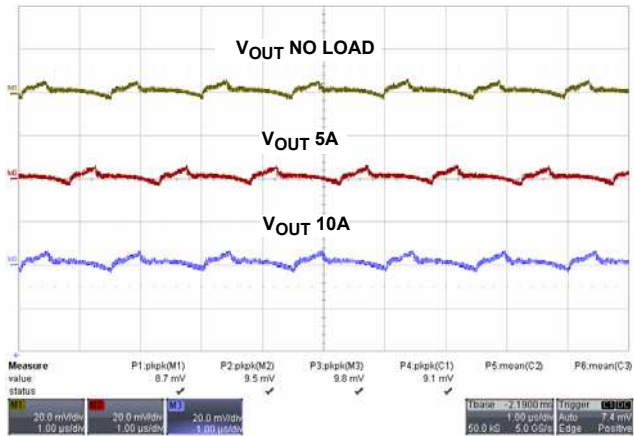

FIGURE 20. 3.3V OUTPUT RIPPLE

## Applications Information

### Programming the Output Voltage ( $R_{SET}$ )

The ISL8200AMMREP has an internal  $0.6V \pm 0.7\%$  reference voltage. Programming the output voltage requires a dividing resistor ( $R_{SET}$ ) between the  $V_{OUT\_SET}$  pin and the  $V_{OUT}$  regulation point. The output voltage can be calculated as shown in Equation 1:

$$V_{OUT} = 0.6 \times \left( 1 + \frac{R_{SET}}{R_{OS}} \right) \quad (EQ. 1)$$

Note: ISL8200AMMREP has integrated  $2.2k\Omega$  resistances into the module dividing resistor for the bottom side ( $R_{OS}$ ). The resistances for different output voltages in single phase operation are listed in Table 1. For a parallel setup, please refer to the current sharing application note (*Coming Soon*).

TABLE 1.  $V_{OUT} - R_{SET}$

$V_{OUT}$	0.6V	0.8V	1.0V	1.2V
$R_{SET}$	$0\Omega$	$732\Omega$	$1.47k\Omega$	$2.2k\Omega$
$V_{OUT}$	1.5V	1.8V	2.0V	2.5V
$R_{SET}$	$3.32k\Omega$	$4.42k\Omega$	$5.11k\Omega$	$6.98k\Omega$
$V_{OUT}$	3.3V	5.0V	6.0V	
$R_{SET}$	$10k\Omega$	$16.2k\Omega$	$20k\Omega$	

The output voltage accuracy can be improved by maintaining the impedance at  $V_{OUTSET}$  (internal  $V_{SEN1+}$ ) at or below  $1k\Omega$  effective impedance. Note: the impedance between  $V_{SEN1+}$  and  $V_{SEN1-}$  is about  $500k\Omega$ .

The module has a minimum input voltage at a given output voltage, which needs to be a minimum of 1.43 times the output voltage if operating at  $F_{SW} = 700kHz$  switching frequency. This is due to the Minimum PWM OFF Time ( $t_{MIN\_OFF}$ ).

The equation to determine the minimum  $PV_{IN}$  to support the required  $V_{OUT}$  is given by Equations 2 and 3; it is recommended to add 0.5V to the result to account for temperature variations.

$$PV_{IN\_MIN} = \frac{V_{OUT} \times t_{SW}}{t_{SW} - t_{MIN\_OFF}} \quad (EQ. 2)$$

$t_{SW}$  = switching period =  $1/F_{SW}$

for the 700kHz switching frequency = 1428ns

$$PV_{IN\_MIN} = 1.43 \times V_{OUT} \quad (EQ. 3)$$

For 3.3V input voltage operation, the  $V_{IN}$  voltage is recommended to be 5V for sufficient gate drive voltage. This can be accomplished by using a voltage greater than or equal to 5V on  $V_{IN}$ , or directly connecting the 5V source to both  $V_{IN}$  and  $PVCC$ .

$V_{IN}$  is the input to the internal LDO that powers the control circuitry while  $PVCC$  is the output of the aforementioned LDO.  $PV_{IN}$  is the power input to the power stage. Figure 21 shows a scenario where the power stage is running at 3.3V and the control circuitry is running at 5.0V; keep in mind that the  $PVCC$  pin is also at 5.0V to ensure that the LDO is not functioning. Figure 22 shows a setup where both the control circuitry and the

power stage is at a 5.0V rail. It is imperative to not cross 5.5V in this setup as that is the voltage limit on the  $PVCC$  pin. Figure 23 is a more general setup and can accommodate  $V_{IN}$  ranges up to 20V;  $PVCC$  is not tied to  $V_{IN}$  and hence the control circuitry is powered by the internal LDO.

The circuit shown in Figure 24 ensures proper startup by injecting current into the  $ISHARE$  line until all phases are ready to start regulating.

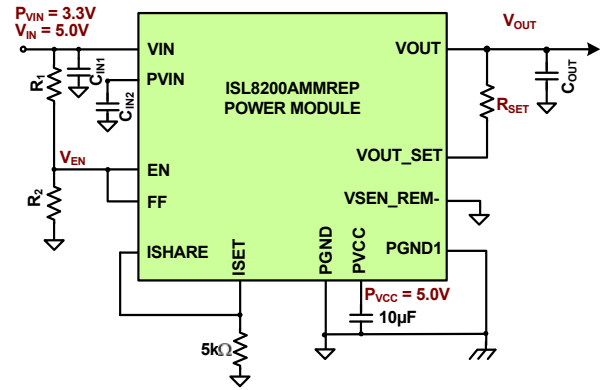

FIGURE 21. 3.3V OPERATION

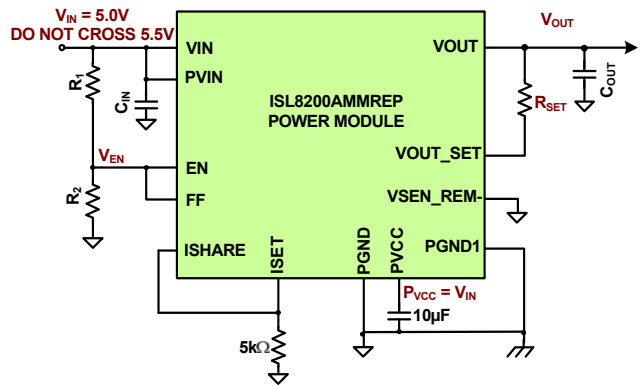

FIGURE 22. 5.0V OPERATION

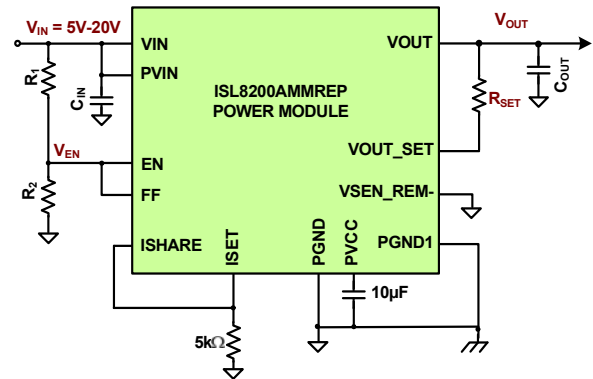

FIGURE 23. 5V TO 20V OPERATION

## Selection of the Input Capacitor

The input filter capacitor should be based on how much ripple the supply can tolerate on the DC input line. The larger the capacitor, the less ripple expected, but consideration should be taken for the higher surge current during power-up. The ISL8200AMMREP provides the soft-start function that controls and limits the current surge. The value of the input capacitor can be calculated by Equation 4:

$$C_{IN(MIN)} = I_O \cdot \frac{D \cdot (1 - D)}{V_{P-P(MAX)} \cdot F_S} \quad (EQ. 4)$$

Where:

$C_{IN(MIN)}$  is the minimum input capacitance ( $\mu F$ ) required

$I_O$  is the output current (A)

$D$  is the duty cycle ( $V_O/V_{IN}$ )

$V_{P-P(MAX)}$  is the maximum peak-to-peak voltage (V)

$F_S$  is the switching frequency (Hz)

In addition to the bulk capacitance, some low Equivalent Series Inductance (ESL) ceramic capacitance is recommended to decouple between the drain terminal of the high side MOSFET and the source terminal of the low side MOSFET. This is used to reduce the voltage ringing created by the switching current across parasitic circuit elements.

## Output Capacitors

The ISL8200AMMREP is designed for low output voltage ripple. The output voltage ripple and transient requirements can be met with bulk output capacitors ( $C_{OUT}$ ) with low enough Equivalent Series Resistance (ESR); the recommended ESR is  $<10m\Omega$ . When the total ESR is below  $4m\Omega$ , a capacitor ( $C_{FF}$ ) between  $2.2nF-10nF$  is recommended;  $C_{FF}$  is placed in parallel with RSET, in between the VOUT and VOUT\_SET pin.  $C_{OUT}$  can be a low ESR tantalum capacitor, a low ESR polymer capacitor or a ceramic capacitor. The typical capacitance is  $330\mu F$  and decoupled ceramic output capacitors are used per phase. The internally optimized loop compensation provides sufficient stability margins for all ceramic capacitor applications with a recommended total value of  $300\mu F$  per phase. Additional output filtering may be needed if further reduction of output ripple or dynamic transient spike is required.

## Using Multiple Phases

The ISL8200AMMREP can be easily connected in parallel with other ISL8200AMMREP modules and current share providing an additional 10A per phase. For 2 phases, simply follow the schematic shown in Figure 4. A rough summary shows that the modules share  $V_{IN}$ ,  $V_{OUT}$ , GND and have their ISHARE pins tied together with a  $10k\Omega$  resistor to ground (per phase). When using 3 phases or more, it is recommended that you add the following circuitry (see Figure 24) to ensure proper startup. The circuit shown in Figure 24 ensures proper startup by injecting current into the ISHARE line until all phases are ready to start regulating. For additional phases, the RC time constant, using  $R_{INC}$  and  $C_G$ , might have to be adjusted to increase the turn on time of the PFET (QSHR). For 3-4 phases, these are the values,  $R_{INC} = 243k$ ,  $R_{PH1} = 15k$ ,  $Q_{SHR} =$  Small Signal PFET,  $C_G = 22nF$ .

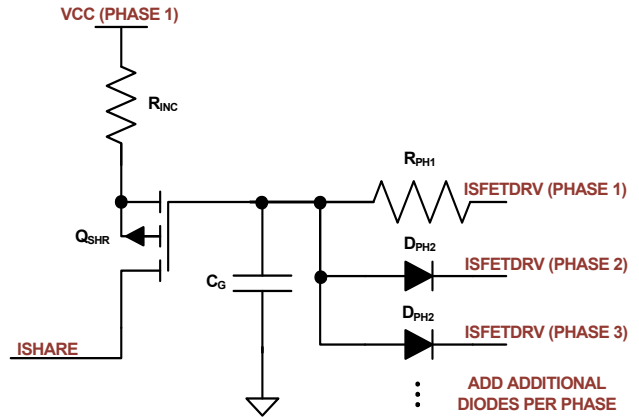

FIGURE 24. STARTUP CIRCUITRY

## Functional Description

### Initialization

The ISL8200AMMREP requires  $V_{CC}$  and  $PVCC$  to be biased by a single supply. Power-On Reset (POR) circuits continually monitor the bias voltages ( $PVCC$  and  $V_{CC}$ ) and the voltage at the EN pin. The POR function initiates soft-start operation 384 clock cycles after the EN pin voltage is pulled to be above 0.8V; all input supplies exceed their POR thresholds and the PLL locking time expires. The enable pin can be used as a voltage monitor and to set desired hysteresis with an internal  $30\mu A$  sinking current going through an external resistor divider. The sinking current is disengaged after the system is enabled. This feature is especially designed for applications that require higher input rail POR for better undervoltage protection. For example, in 12V applications,  $R_{UP} = 53.6k$  and  $R_{DOWN} = 5.23k$  will set the turn-on threshold ( $V_{EN\_RTH}$ ) to 10.6V and turn-off threshold ( $V_{EN\_FTH}$ ) to 9V, with 1.6V hysteresis ( $V_{EN\_HYS}$ ). These numbers are explained in Figure 29 on page 15.

During shutdown or fault conditions, the soft-start is quickly reset while UGATE and LGATE immediately change state ( $<100ns$ ) upon the input dropping below POR.

HIGH = ABOVE POR; LOW = BELOW POR

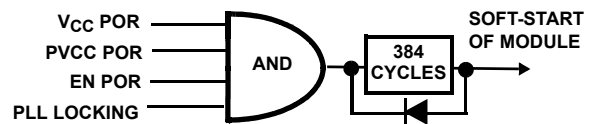

FIGURE 25. SOFT-START INITIALIZATION LOGIC

### Soft-Start

The ISL8200AMMREP has an internal digital pre-charged soft-start circuitry, which has a rise time inversely proportional to the switching frequency and is determined by a digital counter that increments with every pulse of the phase clock. The full soft-start time from 0V to 0.6V can be estimated by Equation 5.

$$t_{SS} = \frac{2560}{f_{SW}} \quad (EQ. 5)$$

# ISL8200AMM

The ISL8200AMMREP has the ability to work under a pre-charged output. The PWM outputs will not be fed to the drivers until the first PWM pulse is seen. The low side MOSFET is held low for the first clock cycle to provide charge for the bootstrap capacitor. If the pre-charged output voltage is greater than the final target level but less than the 113% setpoint, switching will not start until the output voltage is reduced to the target voltage and the first PWM pulse is generated. The maximum allowable pre-charged level is 113%. If the pre-charged level is above 113% but below 120%, the output will hiccup between 113% (LGATE turns on) and 87% (LGATE turns off) while EN is pulled low. If the pre-charged load voltage is above 120% of the targeted output voltage, then the controller will be latched off and not be able to power-up.

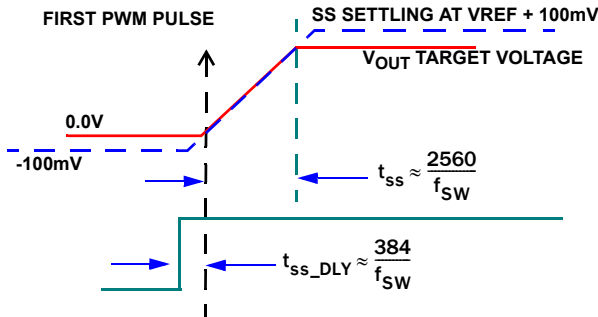

FIGURE 26. SOFT-START WITH  $V_{OUT} = 0V$

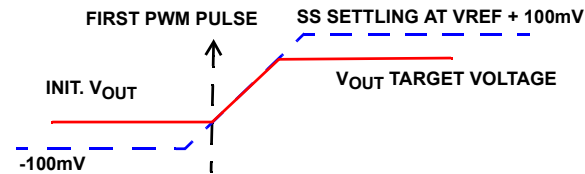

FIGURE 27. SOFT-START WITH  $V_{OUT} < TARGET VOLTAGE$

$$R_{UP} = \frac{V_{EN\_HYS}}{N \times I_{EN\_HYS}} \quad R_{DOWN} = \frac{R_{UP} \cdot V_{EN\_REF}}{V_{EN\_FTH} - V_{EN\_REF}}$$

where N is number of EN pins connected together

$$V_{EN\_FTH} = V_{EN\_RTH} - V_{EN\_HYS}$$

$$\Delta V_{RAMP} = \max(V_{CC\_FF} \times G_{RAMP}, V_{CC} - 1.4V - V_{RAMP\_OFFSET})$$

$$V_{CC\_FF} = \max(0.8V, V_{FF})$$

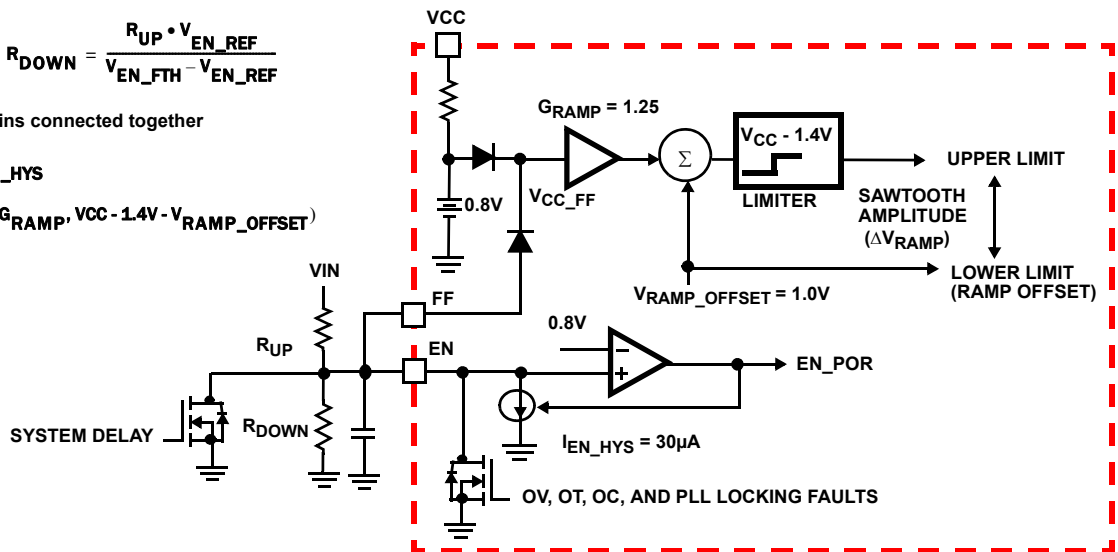

FIGURE 29. SIMPLIFIED ENABLE AND VOLTAGE FEEDFORWARD CIRCUIT

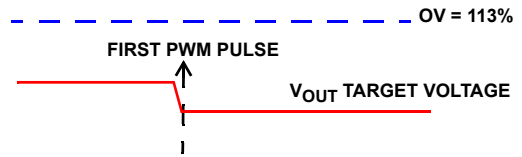

FIGURE 28. SOFT-START WITH  $V_{OUT}$  BELOW  $OV$  BUT ABOVE FINAL TARGET VOLTAGE

## Voltage Feedforward

The voltage applied to the FF pin is fed to adjust the sawtooth amplitude of the channel. The amplitude the sawtooth is set to is 1.25 times the corresponding FF voltage when the module is enabled. This configuration helps to maintain a constant gain ( $G_M = V_{IN} \cdot D_{MAX} / \Delta V_{RAMP}$ ) and input voltage to achieve optimum loop response over a wide input voltage range. The sawtooth ramp offset voltage is 1V (equal to  $0.8V \cdot 1.25$ ), and the peak of the sawtooth is limited to  $V_{CC} - 1.4V$ . With  $V_{CC} = 5.4V$ , the ramp has a maximum peak-to-peak amplitude of  $V_{CC} - 2.4V$  (equal to 3V); so the feed-forward voltage effective range is typically 3x as the ramp amplitude ranges from 1V to 3V.

A 384 cycle delay is added after the system reaches its rising POR and prior to the soft-start. The RC timing at the FF pin should be sufficiently small to ensure that the input bus reaches its static state and the internal ramp circuitry stabilizes before soft-start. A large RC could cause the internal ramp amplitude not to synchronize with the input bus voltage during output start-up or when recovering from faults. A 1nF capacitor is recommended as a starting value for typical applications. The voltage on the FF pin needs to be above 0.8V prior to soft-start and during PWM switching to ensure reliable regulation. In a typical application, FF pin can be shorted to the EN pin.

## Power Good

The Power-Good comparators monitor the voltage on the internal VMON1 pin. The trip points are shown in Figure 30. PGOOD will not be asserted until after the completion of the soft-start cycle. The PGOOD pulls low upon both EN's disabling it or the internal VMON1 pin's voltage is out of the threshold window. PGOOD will not be asserted until after the completion of the soft-start cycle. PGOOD will not pull low until the fault is present for three consecutive clock cycles.

The UV indication is not enabled until the end of soft-start. In a UV event, if the output drops below -13% of the target level due to some reason (cases when EN is not pulled low) other than OV, OC, OT, and PLL faults, PGOOD will be pulled low.

## Current Share

The IAVG\_CS is the current of the module. ISHARE and ISET pins source a copy of IAVG\_CS with 15µA offset, i.e., the full scale will be 126µA.

The share bus voltage ( $V_{ISHARE}$ ) set by an external resistor ( $R_{ISHARE} = R_{ISET}/NCTRL$ ) represents the average current of all active modules. The voltage ( $V_{ISET}$ ) set by  $R_{ISET}$  represents the average current of the corresponding module and is compared with the share bus ( $V_{ISHARE}$ ). The current share error signal (ICSH\_ER) is then fed into the current correction block to adjust each module's PWM pulse accordingly. The current share function provides at least 10% overall accuracy between ICs, up to 3 phases. The current share bus works for up to 6-phase. Figure 4 further illustrates the current sharing aspects of the ISL8200AMMREP.

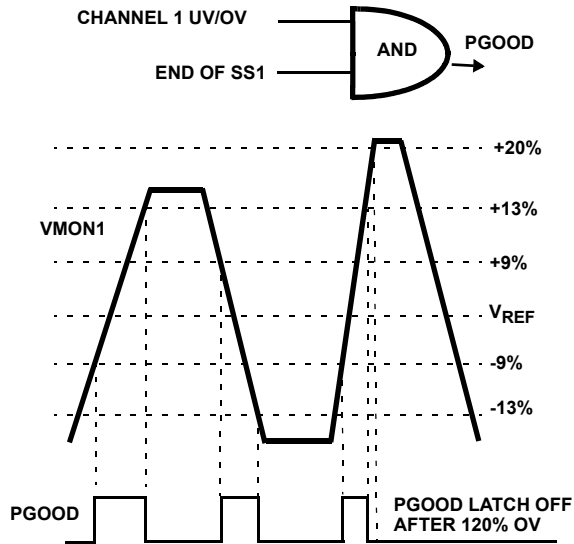

FIGURE 30. POWER-GOOD THRESHOLD WINDOW

When there is only one module in the system, the ISET and ISHARE pins can be shorted together and grounded via a single resistor to ensure zero share error - a resistor value of 5k (paralleling 10k on ISET and ISHARE) will allow operation up to the OCP level.

## Overvoltage Protection (OVP)

The Overvoltage (OV) protection indication circuitry monitors the voltage on the internal VMON1 pin.

OV protection is active from the beginning of soft-start. An OV condition (>120%) would latch the IC off (the high-side MOSFET to latch off permanently; the low-side MOSFET turns on immediately at the time of OV trip and then turns off permanently after the output voltage drops below 87%). The EN and PGOOD are also latched low at OV event. The latch condition can be reset only by recycling  $V_{CC}$ .

There is another non-latch OV protection (113% of target level). At the condition of EN low and the output over 113% OV, the lower side MOSFET will turn on until the output drops below 87%. This is to protect the overall power trains in case of a single channel of a multi-module system detecting OV. The low-side MOSFET always turns on at the conditions of EN = LOW and the output voltage above 113% (all EN pins are tied together) and turns off after the output drops below 87%. Thus, in a high phase count application (multi-module mode), all cascaded modules can latch off simultaneously via the EN pins (EN pins are tied together in multiphase mode), and each IC shares the same sink current to reduce the stress and eliminate the bouncing among phases.

## Over-Temperature Protection (OTP)

When the junction temperature of the IC is greater than +150°C (typically), EN pin will be pulled low to inform other cascaded channels via their EN pins. All connected ENs stay low and release after the IC's junction temperature drops below +125°C (typically), a +25°C hysteresis (typically).

## Overcurrent Protection (OCP)

The OCP function is enabled at startup. The load current sampling ICS1 is sensed by sampling the voltage across Q2 MOSFET  $r_{DS(ON)}$  during turn on through the resistor between OCSET and PHASE pin. IC1 is compared with the Channel Overcurrent Limit '111µA OCP' comparator, and waits 7-cycles before OCP condition is declared. The module's output current (ICS1) plus a fixed internal 15µA offset forms a voltage ( $V_{ISHARE}$ ) across the external resistor,  $R_{ISHARE}$ .  $V_{ISHARE}$  is compared with a precision internal 1.2V threshold for a second method to detect OCP condition.

Multi-module operation can be achieved by connecting the ISHARE pin of two or more modules together. In multi-module operation the voltage on the ISHARE pin correlates to the average current of all active channels. This scheme helps protect from damaging a module(s) in multi-module mode by not having a single module carrying more than 111µA. Note that it is not necessary for the  $R_{ISHARE}$  to be scaled to trip at the same level as the 111µA OCP comparator. Typically the ISHARE pin average current protection level should be higher than the phase current protection level.

With an internal  $R_{ISEN-IN}$  of 2.2kΩ, the OCP level is set to the default value. To lower the OCP level, an external  $R_{ISEN-EX}$  is connected between OCSET and PHASE pin. The relationships between the external  $R_{ISEN-EX}$  values and the typical output current  $I_{OUT(MAX)}$  OCP levels for ISL8200AMMREP are shown in Figures 31 through 33. It is important to note that the OCP level



shown in these graphs is the average output current and not the inductor ripple current.

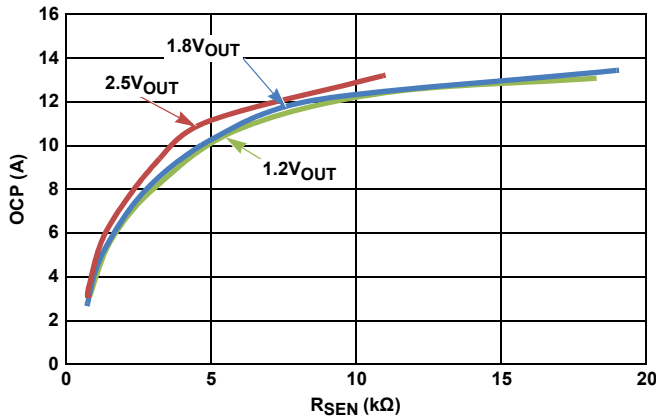

FIGURE 31. 5V<sub>IN</sub>

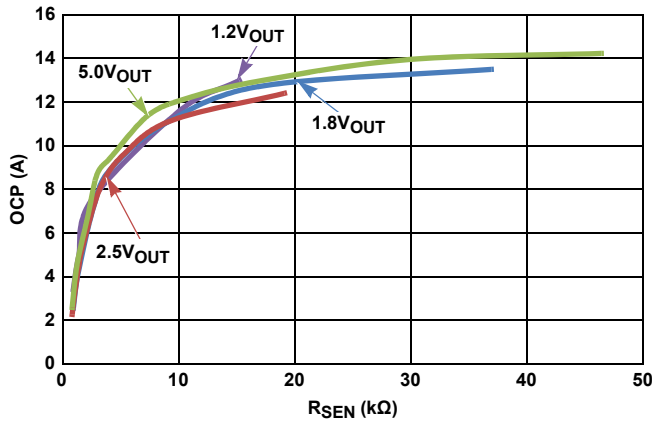

FIGURE 32. 12V<sub>IN</sub>

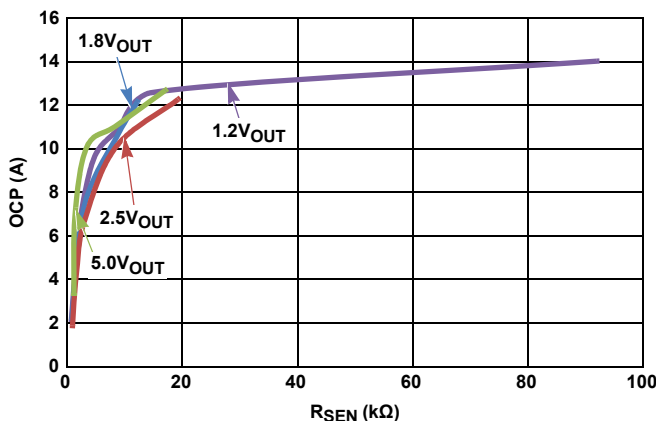

FIGURE 33. 20V<sub>IN</sub>

In a high input voltage, high output voltage application, such as 20V input to 5V output, the inductor ripple becomes excessive due to the fixed internal inductor value. In such applications, the output current will be limited from the rating to approximately 70% of the module's rated current.

When OCP is triggered, the controller pulls EN low immediately to turn off UGATE and LGATE.

For overload and hard short conditions, the overcurrent protection reduces the regulator RMS output current much less than full load by putting the controller into hiccup mode. A delay time, equal to 3 soft-start intervals, is entered to allow the disturbance to be cleared out. After the delay time, the controller then initiates a soft-start interval. If the output voltage comes up and returns to the regulation, PGOOD transitions high. If the OC trip is exceeded during the soft-start interval, the controller pulls EN low again. The PGOOD signal will remain low and the soft-start interval will be allowed to expire. Another soft-start interval will be initiated after the delay interval. If an overcurrent trip occurs again, this same cycle repeats until the fault is removed.

## Fault Handshake

In a multi-module system, with the EN pins wired OR'ed together, all modules can immediately turn off, at one time, when a fault condition occurs in one or more modules. A fault would pull the EN pin low, disabling all the modules and therefore not creating current bounce. Thus, no single channel would be overstressed when a fault occurs.

Since the EN pins are pulled down under fault conditions, the pull-up resistor ( $R_{UP}$ ) should be scaled to sink no more than 5mA current from EN pin. Essentially, the EN pins cannot be directly connected to  $V_{CC}$ .

## Oscillator

The Oscillator is a sawtooth waveform, providing for leading edge modulation with 350ns minimum dead time. The oscillator (Sawtooth) waveform has a DC offset of 1.0V. Each channel's peak-to-peak of the ramp amplitude is set to be proportional to the voltage applied to its corresponding FF pin.

## Frequency Synchronization and Phase Lock Loop

The FSYNC\_IN pin has two primary capabilities: fixed frequency operation and synchronized frequency operation. By tying a resistor (RFS) to PGND1 from the FSYNC\_IN pin, the switching frequency can be set at any frequency between 700kHz and 1.5MHz. The ISL8200AMMREP has an integrated 59kΩ resistor between FSYNC\_IN and PGND1, which sets the default frequency to 700kHz. The frequency setting curve shown in Figure 34 is provided to assist in selecting an externally connected resistor RFS-ext between FSYNC\_IN and PGND1 to increase the switching frequency.

# ISL8200AMM

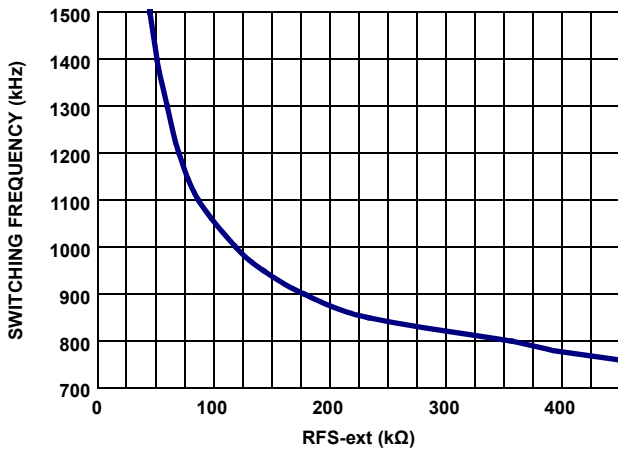

FIGURE 34. RFS-ext vs SWITCHING FREQUENCY

By connecting the FSYNC\_IN pin to an external square pulse waveform (such as the CLKOUT signal, typically 50% duty cycle from another ISL8200AMMREP), the ISL8200AMMREP will synchronize its switching frequency to the fundamental frequency of the input waveform. The voltage range on the FSYNC\_IN pin is  $V_{CC}/2$  to  $V_{CC}$ . The Frequency Synchronization feature will synchronize the leading edge of the CLKOUT signal with the falling edge of Channel 1's PWM clock signal. CLKOUT is not available until the PLL locks.

The locking time is typically 210μs for  $F_{SW} = 700\text{kHz}$ . EN is not released for a soft-start cycle until FSYNC\_IN is stabilized and the PLL is in locking. It is recommended to connect all EN pins together in multiphase configuration.

The loss of a synchronization signal for 13 clock cycles causes the IC to be disabled until the PLL returns locking, at which point a soft-start cycle is initiated and normal operation resumes. Holding FSYNC\_IN low will disable the IC.

## Setting Relative Phase-Shift on CLKOUT

Depending upon the voltage level at PH\_CNTRL, set by the  $V_{CC}$  resistor divider output, the ISL8200AMMREP operates with CLKOUT phase shifted, as shown in Table 2. The phase shift is latched as  $V_{CC}$  raises above POR so it cannot be changed on the fly.

TABLE 2.

DECODING PH_CNTRL RANGE	PHASE FOR CLKOUT WRT CHANNEL 1	REQUIRED PH_CNTRL
<29% of $V_{CC}$	-60°	15% $V_{CC}$
29% to 45% of $V_{CC}$	90°	37% $V_{CC}$
45% to 62% of $V_{CC}$	120°	53% $V_{CC}$
62% to $V_{CC}$	180°	$V_{CC}$

## Layout Guide

To achieve stable operation, low losses, and good thermal performance, some layout considerations are necessary, which are illustrated in Figures 35 and 36.

- The ground connection between PGND1 (pin 15) and PGND (pin 18) should be a solid ground plane under the module.

- Place a high frequency ceramic capacitor between (1) PVIN and PGND (pin 18) and (2) a 10μF between PVCC and PGND1 (pin 15) as close to the module as possible to minimize high frequency noise. High frequency ceramic capacitors close to the module between VOUT and PGND will help to minimize noise at the output ripple.
- Use large copper areas for power path (PVIN, PGND,  $V_{OUT}$ ) to minimize conduction loss and thermal stress. Also, use multiple vias to connect the power planes in different layers.
- Keep the trace connection to the feedback resistor short.
- Use remote sensed traces to the regulation point to achieve a tight output voltage regulation, and keep them in parallel. Route a trace from VSEN\_REM- to a location near the load ground, and a trace from feedback resistor to the point-of-load where the tight output voltage is desired.
- Avoid routing any sensitive signal traces, such as the  $V_{OUT}$  and VSENREM- sensing point near the PHASE pin or any other noise-prone areas.
- FSYNC\_IN is a sensitive pin. If it is not used for receiving an external synchronization signal, then keep the trace connecting to the pin short. A bypass capacitor value of 100pF, connecting between FSYNC\_IN pin and GND1, can help to bypass the noise sensitivity on the pin.

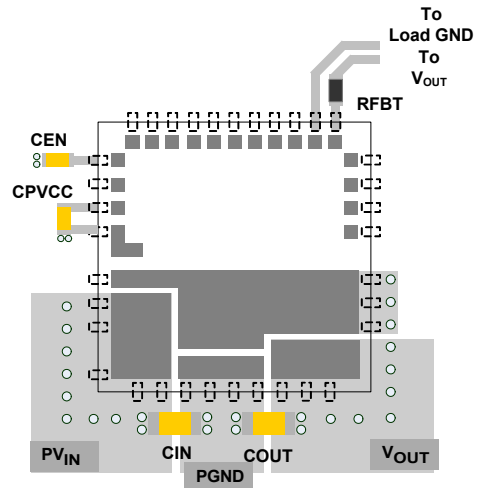

FIGURE 35. RECOMMENDED LAYOUT FOR SINGLE PHASE SETUP

The recommended layout considerations for operating multiple modules in parallel follows the single-phase guidelines as well as these additional points:

- Orient  $V_{OUT}$  towards the load on the same layer and connect with thick direct copper etch directly to minimize the loss.
- Place modules such that pins 1-11 point away from power pads (PD1-4) so that signal busses (EN, ISHARE, CLKOUT-to-FSYNCIN) can be routed without going under the module. Run them along the perimeter as in Figure 36.
- Keep remote sensing traces separate, and connect only at the regulation point. Four separate traces for VSEN\_REM- and RFBT (which stands for remote feedback) as in the example in Figure 36.

# ISL8200AMM

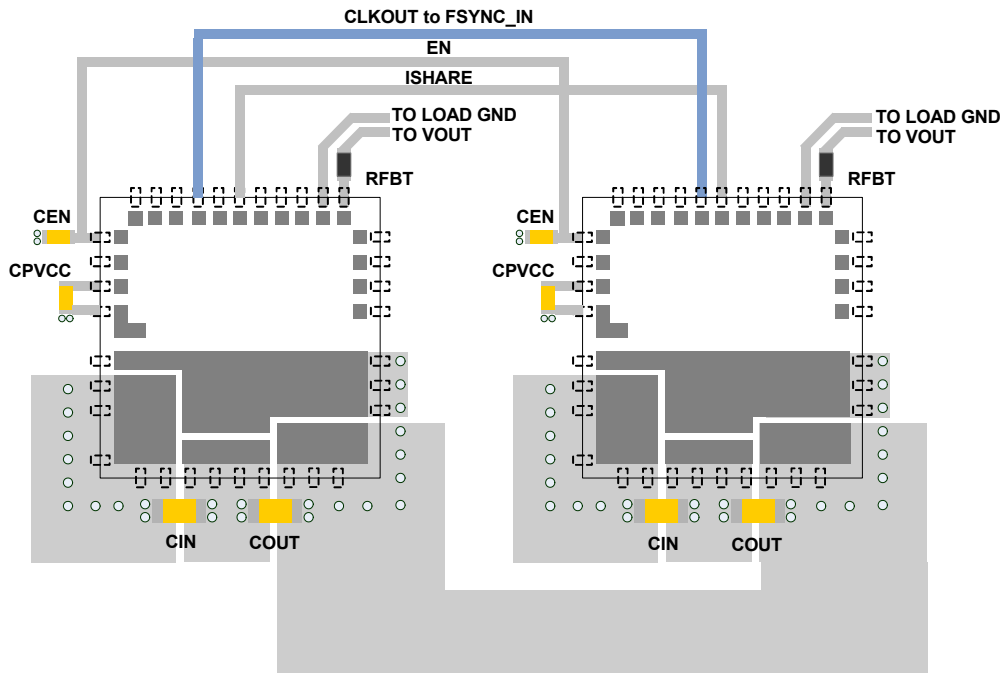

FIGURE 36. RECOMMENDED LAYOUT FOR DUAL PHASE SETUP

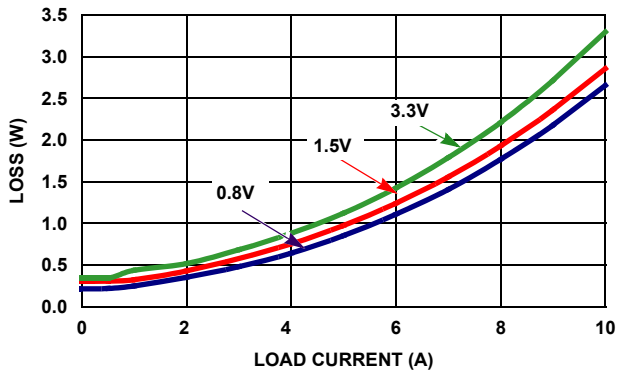

FIGURE 37. POWER LOSS vs LOAD CURRENT (5V<sub>IN</sub>) 0 LFM FOR VARIOUS OUTPUT VOLTAGES

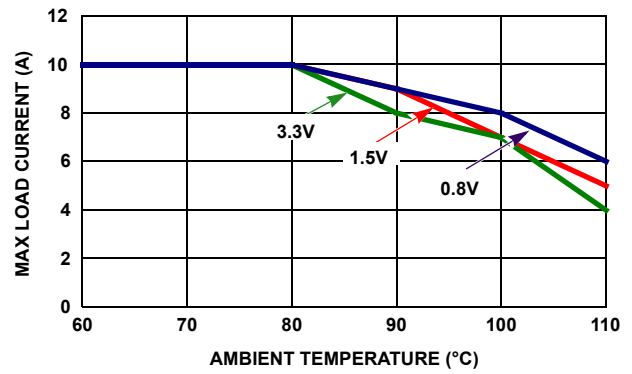

FIGURE 38. DERATING CURVE (5V<sub>IN</sub>) 0 LFM FOR VARIOUS OUTPUT VOLTAGES

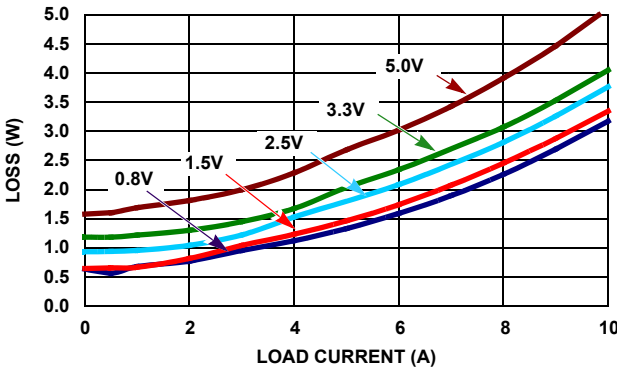

FIGURE 39. POWER LOSS vs LOAD CURRENT (12V<sub>IN</sub>) 0 LFM FOR VARIOUS OUTPUT VOLTAGES

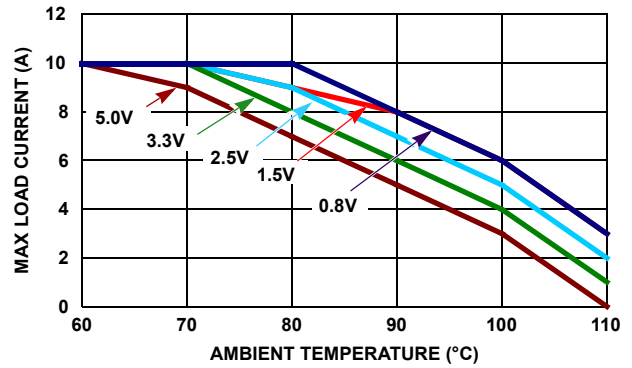

FIGURE 40. DERATING CURVE (12V<sub>IN</sub>) 0 LFM FOR VARIOUS OUTPUT VOLTAGES

## Thermal Considerations

Empirical power loss curves, shown in Figures 37 to 40, along with  $\theta_{JA}$  from thermal modeling analysis can be used to evaluate the thermal consideration for the module. The derating curves are derived from the maximum power allowed while maintaining the temperature below the maximum junction temperature of +125°C. In actual application, other heat sources and design margin should be considered.

## Package Description

The structure of the ISL8200AMMREP belongs to the Quad Flat-pack No-lead package (QFN). This kind of package has advantages, such as good thermal and electrical conductivity, low weight and small size. The QFN package is applicable for surface mounting technology and is being more readily used in the industry. The ISL8200AMMREP contains several types of devices, including resistors, capacitors, inductors and control ICs. The ISL8200AMMREP is a copper lead-frame based package with exposed copper thermal pads, which have good electrical and thermal conductivity. The copper lead frame and multi component assembly is overmolded with polymer mold compound to protect these devices.

The package outline and typical PCB layout pattern design and typical stencil pattern design are shown in the package outline drawing L23.15x15 on page 23. The module has a small size of 15mm x 15mm x 2.2mm. Figure 41 shows typical reflow profile parameters. These guidelines are general design rules. Users could modify parameters according to their application.

## PCB Layout Pattern Design

The bottom of ISL8200AMMREP is a lead-frame footprint, which is attached to the PCB by surface mounting process. The PCB layout pattern is shown in the Package Outline Drawing L23.15x15 on page 23. The PCB layout pattern is essentially 1:1 with the QFN exposed pad and I/O termination dimensions, except for the PCB lands being a slightly extended distance of 0.2mm (0.4mm max) longer than the QFN terminations, which allows for solder filleting around the periphery of the package. This ensures a more complete and inspectable solder joint. The thermal lands on the PCB layout should match 1:1 with the package exposed die pads.

## Thermal Vias

A grid of 1.0mm to 1.2mm pitch thermal vias, which drops down and connects to buried copper plane(s), should be placed under the thermal land. The vias should be from 0.3mm to 0.33mm in diameter with the barrel plated with 1.0 ounce copper. Although adding more vias (by decreasing via pitch) will improve the thermal performance, diminishing returns will be seen as more

and more vias are added. Simply use as many vias as practical for the thermal land size and your board design rules allow.

## Stencil Pattern Design

Reflowed solder joints on the perimeter I/O lands should have about a 50µm to 75µm (2mil to 3mil) standoff height. The solder paste stencil design is the first step in developing optimized, reliable solder joints. Stencil aperture size to land size ratio should typically be 1:1. The aperture width may be reduced slightly to help prevent solder bridging between adjacent I/O lands. To reduce solder paste volume on the larger thermal lands, it is recommended that an array of smaller apertures be used instead of one large aperture. It is recommended that the stencil printing area cover 50% to 80% of the PCB layout pattern. A typical solder stencil pattern is shown in the Package Outline Drawing L23.15x15 on page 24. The gap width between pad to pad is 0.6mm. The user should consider the symmetry of the whole stencil pattern when designing its pads. A laser cut, stainless steel stencil with electropolished trapezoidal walls is recommended. Electropolishing "smooths" the aperture walls resulting in reduced surface friction and better paste release, which reduces voids. Using a trapezoidal section aperture (TSA) also promotes paste release and forms a "brick like" paste deposit that assists in firm component placement. A 0.1mm to 0.15mm stencil thickness is recommended for this large pitch (1.3mm) QFN.

## Reflow Parameters

Due to the low mount height of the QFN, "No Clean" Type 3 solder paste per ANSI/J-STD-005 is recommended. Nitrogen purge is also recommended during reflow. A system board reflow profile depends on the thermal mass of the entire populated board, so it is not practical to define a specific soldering profile just for the QFN. The profile given in Figure 41 is provided as a guideline, to be customized for varying manufacturing practices and applications.

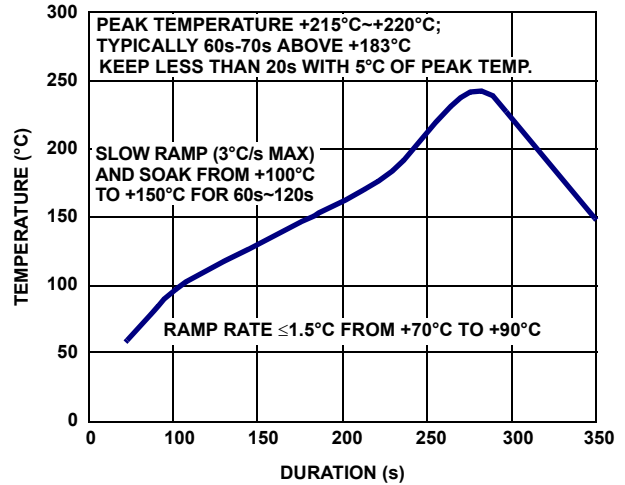

FIGURE 41. TYPICAL REFLOW PROFILE

# ISL8200AMM

## Revision History

The revision history provided is for informational purposes only and is believed to be accurate, but not warranted. Please go to web to make sure you have the latest Rev.

DATE	REVISION	CHANGE
November 27, 2012	FN8287.1	Abbreviated part number at top of all pages from ISL8200AMMREP to ISL8200AMM.
October 12, 2012	FN8287.0	Initial Release.

## Products

Intersil Corporation is a leader in the design and manufacture of high-performance analog semiconductors. The Company's products address some of the industry's fastest growing markets, such as, flat panel displays, cell phones, handheld products, and notebooks. Intersil's product families address power management and analog signal processing functions. Go to [www.intersil.com/products](http://www.intersil.com/products) for a complete list of Intersil product families.

For a complete listing of Applications, Related Documentation and Related Parts, please see the respective product information page. Also, please check the product information page to ensure that you have the most updated datasheet: [ISL8200AMM](http://www.intersil.com/products)

To report errors or suggestions for this datasheet, please go to [www.intersil.com/askourstaff](http://www.intersil.com/askourstaff)

FITs are available from our website at <http://rel.intersil.com/reports/search.php>

For additional products, see [www.intersil.com/product\\_tree](http://www.intersil.com/product_tree)

Intersil products are manufactured, assembled and tested utilizing ISO9000 quality systems as noted in the quality certifications found at [www.intersil.com/design/quality](http://www.intersil.com/design/quality)

*Intersil products are sold by description only. Intersil Corporation reserves the right to make changes in circuit design, software and/or specifications at any time without notice. Accordingly, the reader is cautioned to verify that data sheets are current before placing orders. Information furnished by Intersil is believed to be accurate and reliable. However, no responsibility is assumed by Intersil or its subsidiaries for its use; nor for any infringements of patents or other rights of third parties which may result from its use. No license is granted by implication or otherwise under any patent or patent rights of Intersil or its subsidiaries.*

For information regarding Intersil Corporation and its products, see [www.intersil.com](http://www.intersil.com)

# Package Outline Drawing

## L23.15x15

23 LEAD QUAD FLAT NO-LEAD PLASTIC PACKAGE (PUNCH QFN)

Rev 3, 10/10

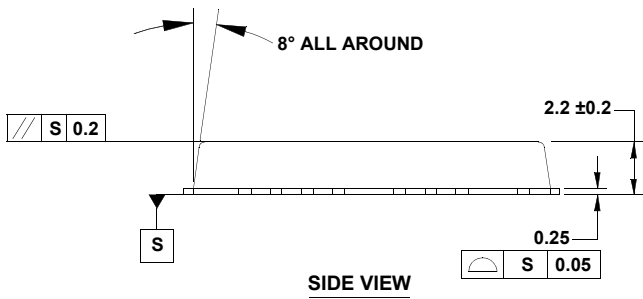
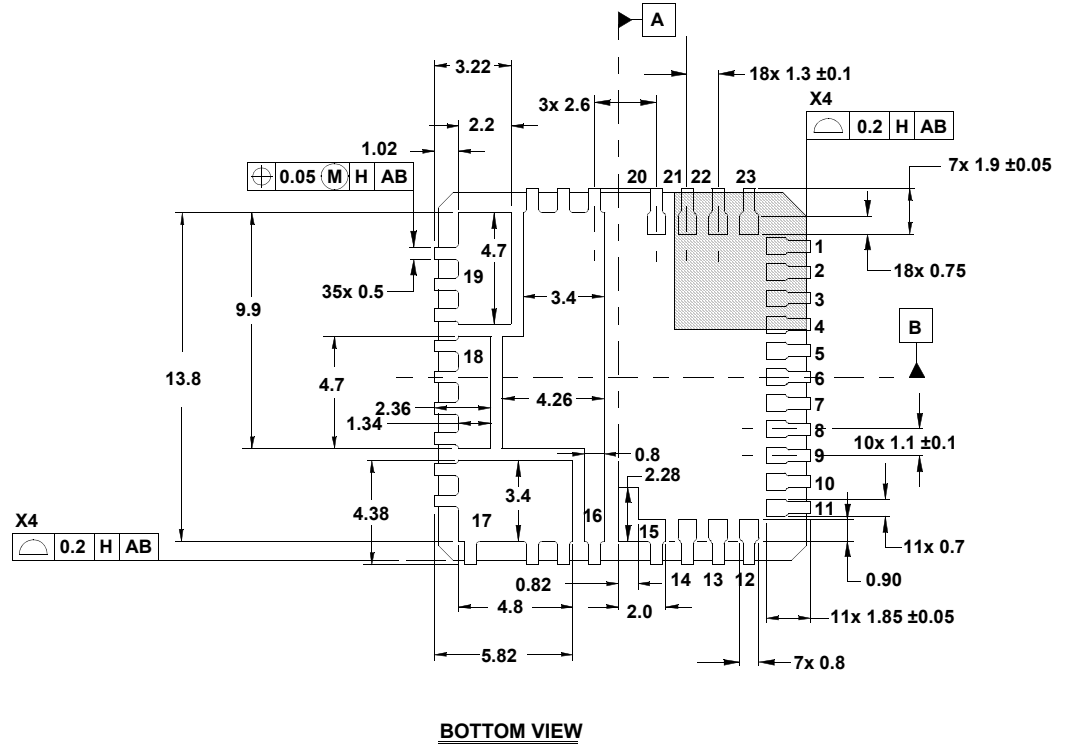
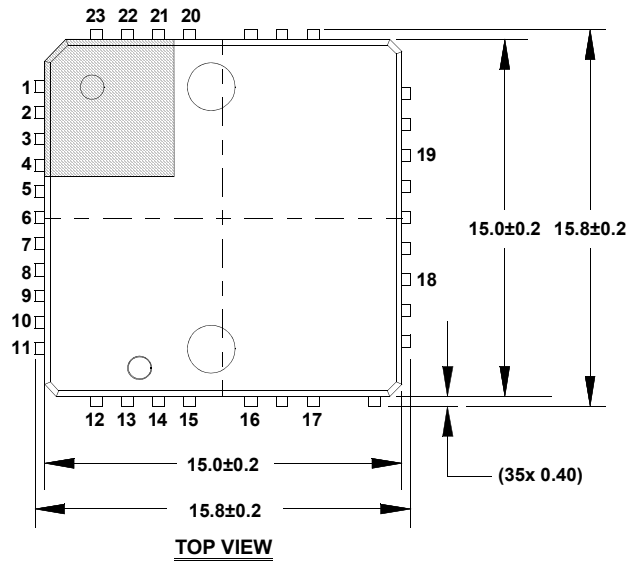

### NOTES:

1. Dimensions are in millimeters.
2. Unless otherwise specified, tolerance : Decimal ± 0.2; Body Tolerance ±0.2mm
3. The configuration of the pin #1 identifier is optional, but must be located within the zone indicated. The pin #1 identifier may be either a mold or mark feature.

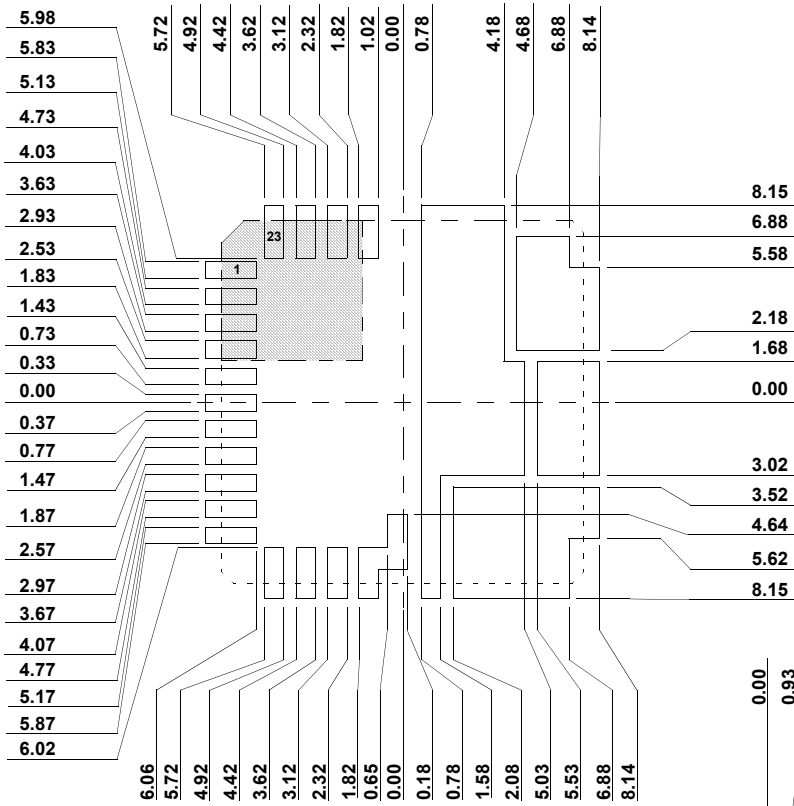

TYPICAL RECOMMENDED LAND PATTERN

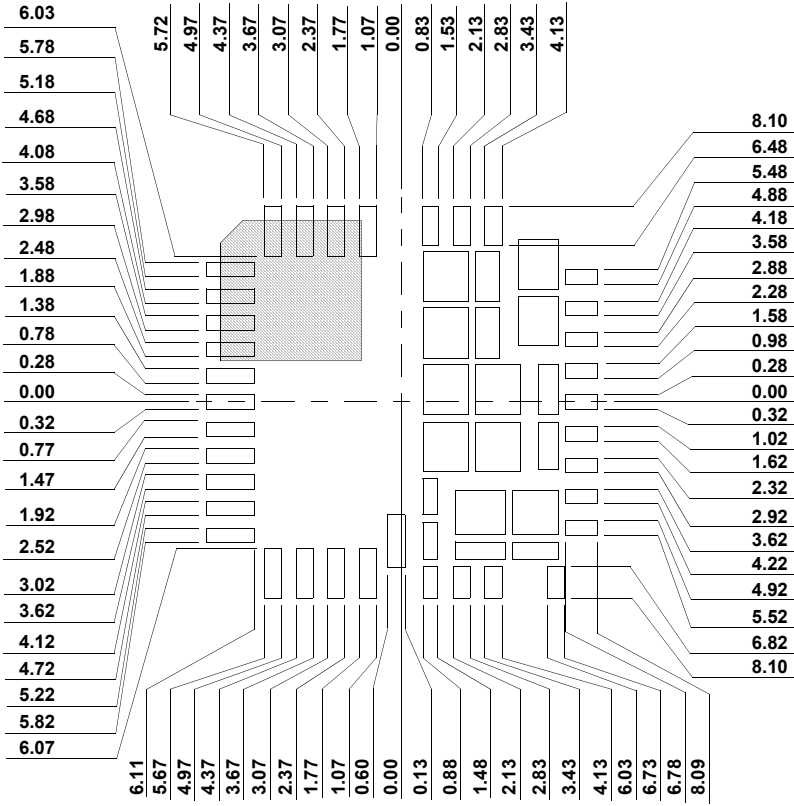

STENCIL PATTERN WITH SQUARE PADS-1

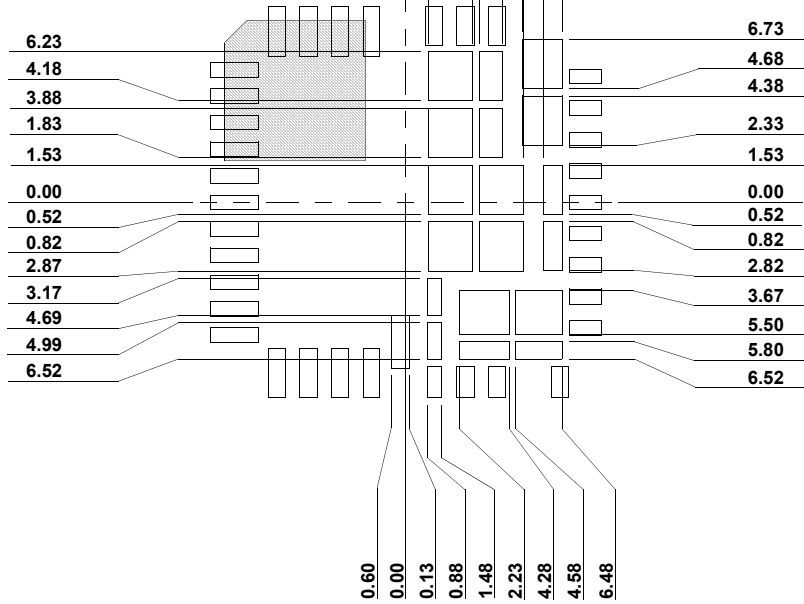

STENCIL PATTERN WITH SQUARE PADS-2