

High Efficiency 5V, 10A Buck Regulator

ISL95210

The ISL95210 is a high-efficiency step-down regulator that can deliver 10A of output current from a 5V input. The small 4mmx6mm QFN package and only four external components provide a very small total solution size. Low resistance internal MOSFETs deliver excellent efficiency and permit full power operation in a +90°C ambient without airflow.

The regulator operates from an input voltage of 2.97V to 5.5V, and provides a 0.6% accurate output voltage over the full operating temperature range. Intersil's patented R4™ control architecture provides exceptional transient response with no external compensation components. The output voltage may be programmed by an internal DAC or by an external resistor divider (see "Output Voltage Programming" on page 11 for more details).

Several digital control signals provide flexibility for users that want additional features. Switching frequency, switching mode, output voltage margining and daisy-chained power-good functions are all programmed by these pins. The ISL95210 also includes comprehensive internal protection for overvoltage, undervoltage, overcurrent and over-temperature conditions.

Related Literature

- See [AN1485](#), "ISL95210 10A Integrated FET Regulator Evaluation Board Setup Procedure"

Features

- 10A Continuous Output Current
- 2.97V to 5.5V Input Voltage Range
- Up to 95% Efficiency
- Full Power Operation in +90°C Ambient without Airflow
- R4™ Control Architecture Delivers Excellent Transient Response Without Compensation
- Pin Selectable Output Voltage Programming
- ±0.6% Output Voltage Accuracy Over Full Operating Temperature Range
- Programmable Enhanced Light-Load Efficiency Operation
- Output Voltage Margining and Power-good Monitor
- Small 6mmx4mm QFN Package

Applications

- Point-of-Load Power Supplies
- Notebook Computer Power
- General Purpose Power Rail Generation

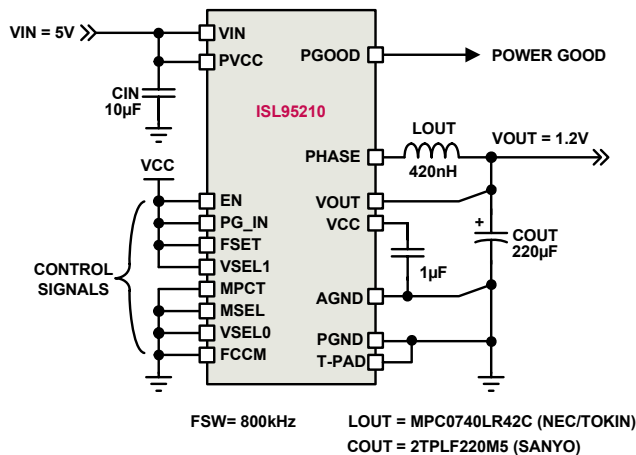

FIGURE 1. 10A DC/DC CONVERTER USING ONLY 4 EXTERNAL COMPONENTS

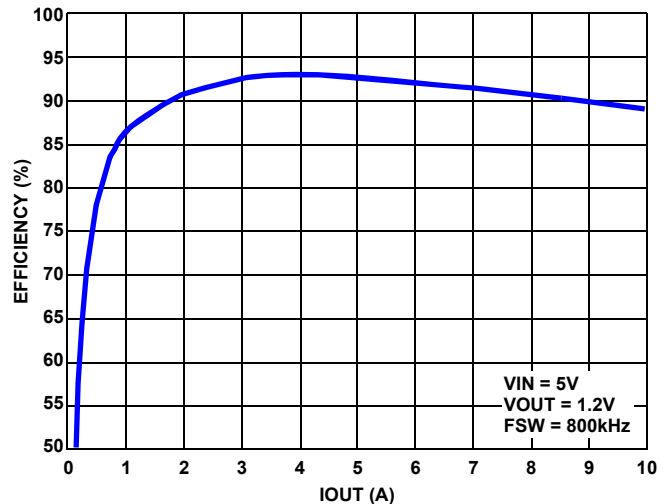
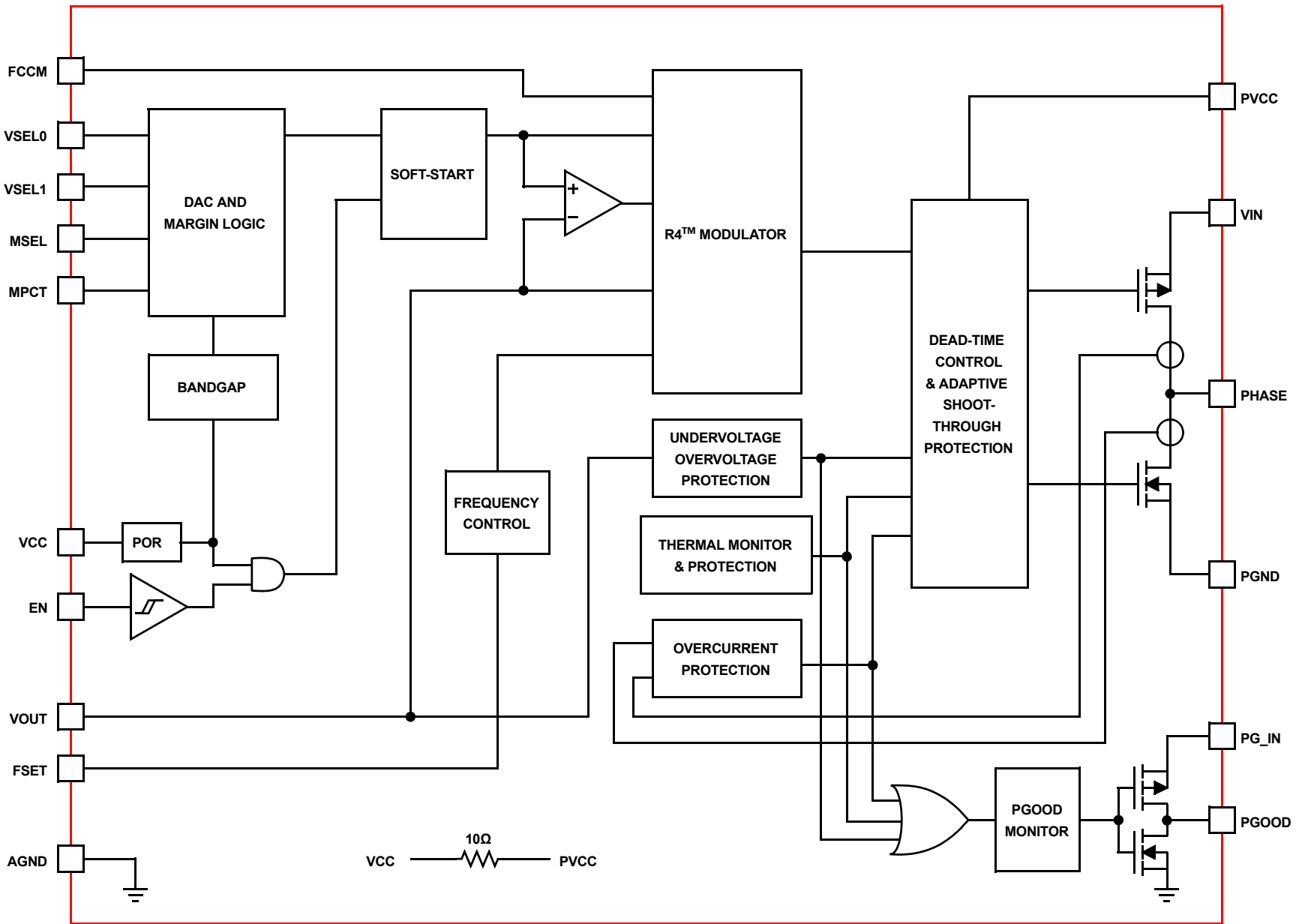
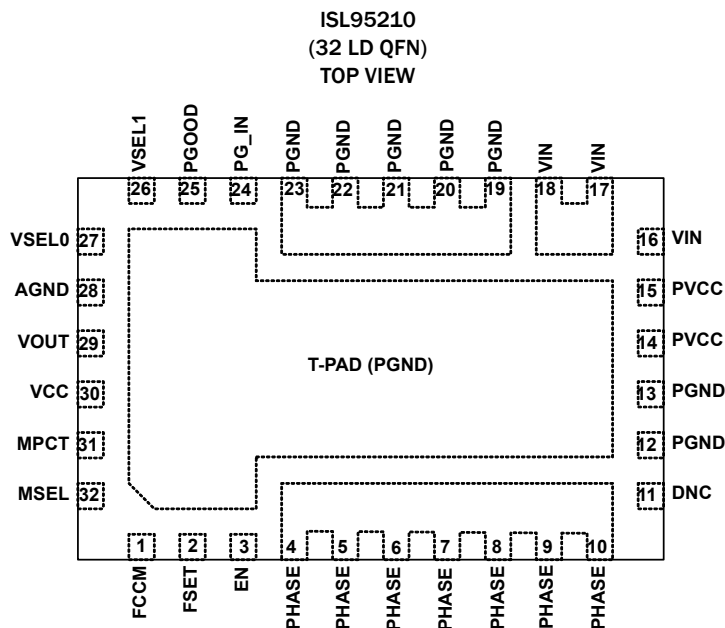

FIGURE 2. EFFICIENCY OF CIRCUIT SHOWN IN FIGURE 1 (INCLUDES INDUCTOR LOSSES)

Functional Block Diagram



Pin Configuration



Functional Pin Descriptions

PIN	NAME	FUNCTION
T-PAD (Thermal Pad)	PGND	Power ground. This thermal pad provides a return path for power stage and switching currents, as well as a thermal path for removing heat from the IC into the board. Place thermal vias in the pad to the PGND plane.
1	FCCM	Logic input for operating mode selection. Connect this pin to VCC for CCM regulation only. Connect this pin to AGND to allow discontinuous conduction mode for light-load efficiency. Float this pin for audio mode light-load switching.
2	FSET	Tri-state digital input for programming the regulator switching frequency. Pull this pin to VCC for 800kHz switching. Pull this pin to GND for 400kHz switching. Leave this pin floating for 533kHz switching.
3	EN	Logic input for enabling and disabling output voltage regulation. Pull this pin to VCC to begin regulation. Pull this pin to AGND to disable regulation.
4, 5, 6, 7, 8, 9, 10	PHASE	Power stage switching node for output voltage regulation. Connect to the output inductor. All PHASE pins must be electrically connected together on the printed circuit board.
11	DNC	Do not connect. This pin must be left floating under all conditions.
12, 13, 19, 20, 21, 22, 23	PGND	Power ground. This pin provides a return path for power stage and switching currents. All PGND pins must be electrically connected together on the printed circuit board.
14, 15	PVCC	Power input for the integrated MOSFET gate drivers. Connect to a 5V ($\pm 10\%$) supply. Both PVCC pins must be shorted on the printed circuit board. VIN and PVCC may be tied together (see Figure 1) when operating from a nominal 5V supply. However, PVCC requires a 5V ($\pm 10\%$) supply irrespective of VIN. It is connected to VCC through an integrated 10Ω resistor and therefore doubles as the power supply for IC bias. If VIN is below 4.5V, PVCC must receive a separate power supply input and decoupling capacitor ($1\mu\text{F}$ typical).
16, 17, 18	VIN	Power input for buck regulation stage. Bypass to PGND with one $10\mu\text{F}$ or $22\mu\text{F}$ ceramic capacitor. Connect to a 2.97V to 5.5V supply. All VIN pins must be electrically connected together on the printed circuit board.
24	PG_IN	Input voltage for the power-good CMOS output. Connect this pin to the desired PGOOD output high level.
25	PGOOD	Active CMOS output for power-good indication. High state is indicated when the output voltage is in regulation, and output is logic low otherwise. Logic high level is set by the voltage on the PG_IN pin.
26	VSEL1	DAC logic MSB input. Used to program preset output voltages of 0.60V, 0.75V, 0.90V, 1.00V, 1.05V, 1.10V, 1.20V, 1.50V, and 1.80V.
27	VSEL0	DAC logic LSB input. Used to program preset output voltages of 0.60V, 0.75V, 0.90V, 1.00V, 1.05V, 1.10V, 1.20V, 1.50V, and 1.80V.

ISL95210

Functional Pin Descriptions (Continued)

PIN	NAME	FUNCTION
28	AGND	Ground reference for analog signals. Connect this pin to the ground plane.
29	VOUT	Sense point for output voltage regulation and output soft-discharge. Connect to the desired regulation point. A resistor divider can be used to program VOUT away from preset DAC and MARGIN values. However, the divider must not set VOUT more than 5% from the programmed value. See "Output Voltage Programming" on page 11 and Figure 34 for more information on this implementation.
30	VCC	Power supply input used for regulator bias and precision references. Place a high frequency ceramic capacitor (0.1 μ F to 1 μ F) to AGND. PVCC provides power to VCC through an integrated 10 Ω resistor.
31	MPCT	3-state logic input for programming the amount of output voltage margining as controlled by the MSEL pin. Pull the pin to GND for \pm 15% margining, to VCC for \pm 20% margining, and float the pin for \pm 10% margining.
32	MSEL	Digital input for control of output voltage margining. Pull this pin to VCC to margin the output voltage to the high value. Leave this pin floating to margin the output voltage low. Pull this pin to AGND to regulate the nominally programmed output voltage value. The margin amount is dictated by the MPCT pin.

Ordering Information

PART NUMBER (Notes 1, 2, 3)	PART MARKING	TEMP RANGE (°C)	PACKAGE (Pb-free)	PKG. DWG. #
ISL95210HRZ	95210 HRZ	-10 to +100	32 Ld 6x4 QFN	L32.6x4B
ISL95210IRZ	95210 IRZ	-40 to +100	32 Ld 6x4 QFN	L32.6x4B
ISL95210EVAL1Z	Evaluation Board			

NOTES:

1. Add "-T*" suffix for tape and reel. Please refer to [TB347](#) for details on reel specifications.
2. These Intersil Pb-free plastic packaged products employ special Pb-free material sets, molding compounds/die attach materials, and 100% matte tin plate plus anneal (e3 termination finish, which is RoHS compliant and compatible with both SnPb and Pb-free soldering operations). Intersil Pb-free products are MSL classified at Pb-free peak reflow temperatures that meet or exceed the Pb-free requirements of IPC/JEDEC J STD-020.
3. For Moisture Sensitivity Level (MSL), please see device information page for [ISL95210](#). For more information on MSL please see techbrief [TB363](#).

ISL95210

Absolute Maximum Ratings

All pins	-0.3V to +6V (DC)
PHASE	-2V to +10V (< 10ns)
VIN	-0.3V to 8V (< 10ns)

Recommended Operating Conditions

VCC Supply Voltage	+5V ±10%
PVCC Supply Voltage	+5V ±10%
VIN Supply Voltage	+2.97V to +5.5V
Junction Temperature (ISL95210HRZ)	-10 °C to +125 °C
Junction Temperature (ISL95210IRZ)	-40 °C to +125 °C

Thermal Information

Thermal Resistance (Typical)	θ_{JA} (°C/W)	θ_{JC} (°C/W)
32 Ld QFN Package (Notes 4, 5)	40	4
Maximum Junction Temperature	+150 °C	
Maximum Storage Temperature Range	-65 °C to +150 °C	
Pb-Free Reflow Profile	see link below http://www.intersil.com/pbfree/Pb-FreeReflow.asp	

CAUTION: Do not operate at or near the maximum ratings listed for extended periods of time. Exposure to such conditions may adversely impact product reliability and result in failures not covered by warranty.

NOTES:

- θ_{JA} is measured in free air with the component mounted on a high effective thermal conductivity test board with “direct attach” features. See Tech Brief [TB379](#).
- For θ_{JC} , the “case temp” location is the center of the exposed metal pad on the package underside.

Electrical Specifications

Recommended Operating Conditions, Unless Otherwise Specified. **Boldface limits apply over the operating temperature range (-10 °C to +100 °C for ISL95210HRZ; -40 °C to +100 °C for ISL95210IRZ).**

PARAMETER	TEST CONDITIONS	MIN (Note 7)	TYP	MAX (Note 7)	UNITS
BIAS SUPPLIES					
Shutdown Supply Current [PVCC]	EN = low, VIN = PVCC = high		0.4	10	μA
Switching Supply Current [PVCC]	EN = high, VCC = high, FSET = GND(400kHz), FCCM = high		7.2		mA
	EN = high, VCC = high, FSET = FLOAT (533kHz), FCCM = high		8.9		mA
	EN = high, VCC = high, FSET = high (800kHz), FCCM = high		12.2		mA
Standby Supply Current [PVCC]	EN = high, VCC = high, FCCM = low, IOUT = 0A		1.9	2.7	mA
VCC POR (Power-On Reset) Threshold	VCC rising	4.25		4.50	V
	VCC falling	4.00		4.25	V
PWM MODULATOR					
Oscillator Frequency Accuracy, F_{SW} (ISL95210HRZ)	FSET = GND (400kHz)/FLOAT (533kHz)/VCC (800kHz), $T_A = +25 °C$	-5		5	%
	FSET = GND (400kHz)/FLOAT (533kHz)/VCC (800kHz), -10 °C to +100 °C	-10		10	%
Oscillator Frequency Accuracy, F_{SW} (ISL95210IRZ)	FSET = GND (400kHz)/FLOAT (533kHz)/VCC (800kHz), -40 °C to +100 °C	-15		15	%
CONTROL THRESHOLDS					
EN Rising Threshold				2.0	V
EN Falling Threshold		1.0			V
FCCM, MPCT, MSEL, FSET, VSEL_ Input Low Threshold		1.20	1.50	1.80	V
FCCM, MPCT, MSEL, FSET, VSEL_ Input Floating Voltage	Input impedance > 1MΩ	1.85	2.00	2.15	V
FCCM, MPCT, MSEL, FSET, VSEL_ Input High Threshold		2.2	2.50	2.8	V

ISL95210

Electrical Specifications Recommended Operating Conditions, Unless Otherwise Specified. **Boldface limits apply over the operating temperature range (-10°C to +100°C for ISL95210HRZ; -40°C to +100°C for ISL95210IRZ).** (Continued)

PARAMETER	TEST CONDITIONS	MIN (Note 7)	TYP	MAX (Note 7)	UNITS
REFERENCE AND DAC					
System Accuracy ISL95210HRZ -10°C to +100°C	VOUT = {0.700V to 2.1625V}, VIN = 5V	-0.60		0.60	%
	VOUT = {0.48125V to 0.700V}, VIN = 5V	-0.75		0.75	%
System Accuracy ISL95210IRZ -40°C to +100°C	VOUT = {0.700V to 2.1625V}, VIN = 5V	-0.75		0.75	%
	VOUT = {0.48125V to 0.700V}, VIN = 5V	-1		1	%
Line Regulation Accuracy	4.5V < VIN < 5.5V		0.05		%
Load Regulation Accuracy	FCCM = high, Inductor DCR = 2mΩ		0.08		%
SOFT-START RAMP					
Soft-Start and VSEL Slew Rate		1.6	2.3	3.0	mV/μs
PROTECTION					
Overcurrent Trip Level	Valley Current Limit (8 PWM Pulse Count)	10	12.5	14	A
	Peak Way-Overcurrent (~1μs delay)	28	35	43	A
Undervoltage Threshold	VOUT:VDAC	81	84	87	%
Overvoltage Rising Threshold	VOUT:VDAC	112	116	120	%
Overvoltage Falling Threshold	VOUT:VDAC	99	102	106	%
Power-Good Pull-Up Resistance		1.8	2.3	2.8	kΩ
Power-Good Pull-Down Resistance		30	50	70	Ω
VOUT Soft-Discharge Resistance	All Shutdown Conditions	25	45	65	Ω
POWER MOSFET ON-RESISTANCE					
High-Side PMOS	+25°C only			16.52	mΩ
High-Side PMOS			14.8	19.5	mΩ
Low-Side NMOS	+25°C only			4.28	mΩ
Low-Side NMOS			3.8	5.7	mΩ
OVER-TEMPERATURE SHUTDOWN (Note 6)					
Thermal Shutdown Setpoint			150		°C
Thermal Recovery Setpoint			125		°C

NOTES:

- Thermal impedance measured in still air on the ISL95210EVAL1Z REV B evaluation board with 800kHz setup. See [AN1485](#).
- Compliance to datasheet limits is assured by one or more methods: production test, characterization and/or design.

Typical Performance Curves

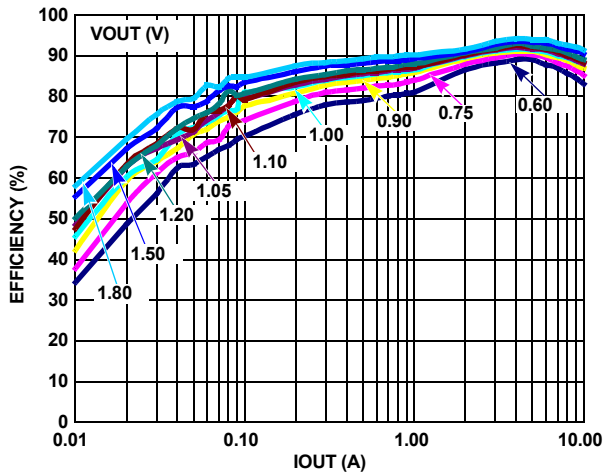

FIGURE 3. 800kHz EFFICIENCY FCCM = LOW

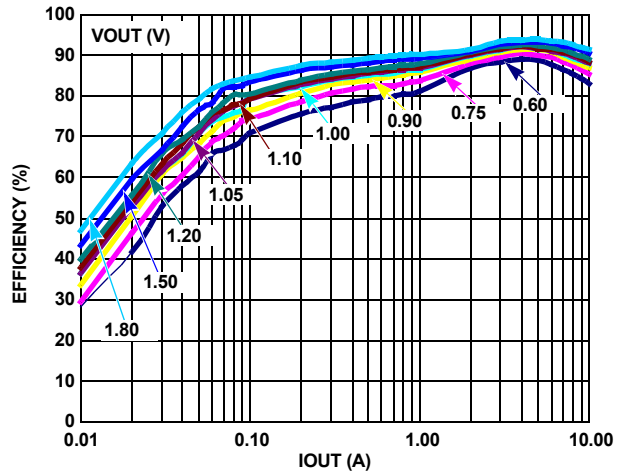

FIGURE 4. 800kHz EFFICIENCY FCCM = FLOAT

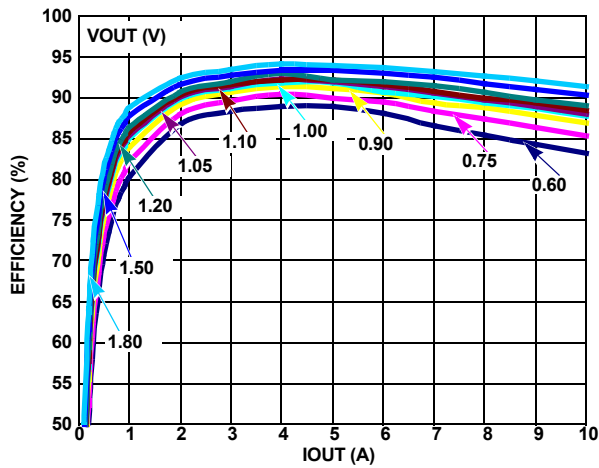

FIGURE 5. 800kHz EFFICIENCY FCCM = HIGH

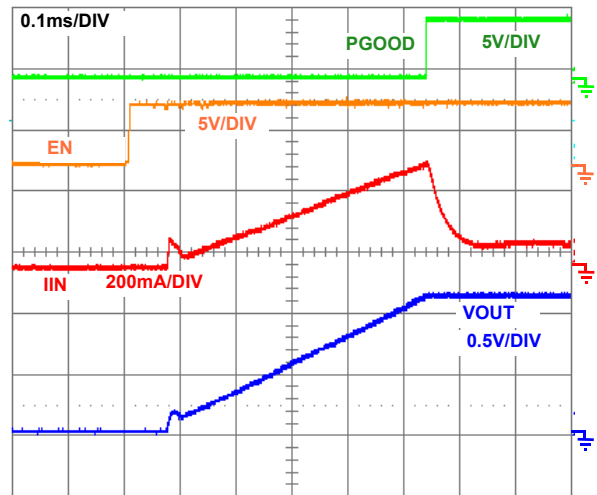

FIGURE 6. NORMAL START-UP

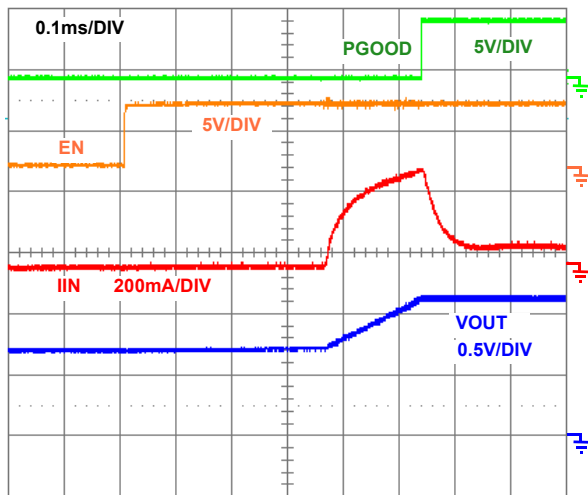

FIGURE 7. PRE-BIASED START-UP

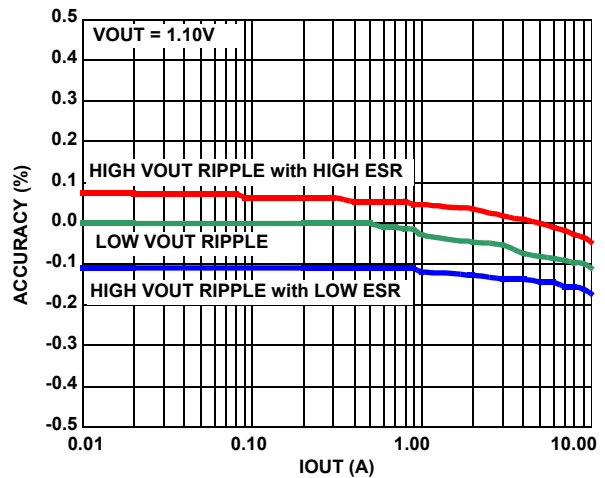

FIGURE 8. CCM OUTPUT VOLTAGE LOAD REGULATION

Typical Performance Curves (Continued)

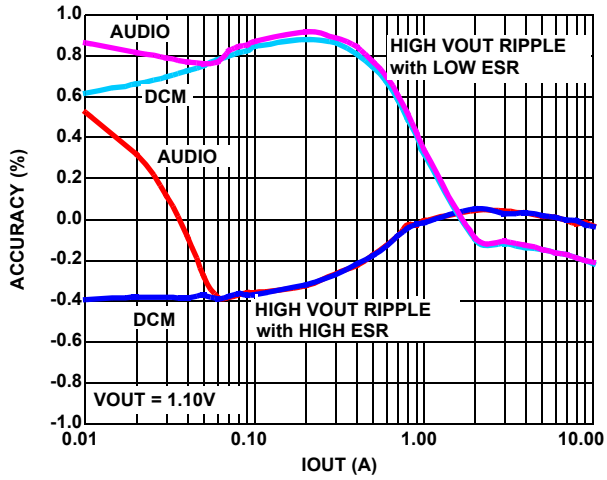

FIGURE 9. OUTPUT VOLTAGE LOAD REGULATION (LOG SCALE)

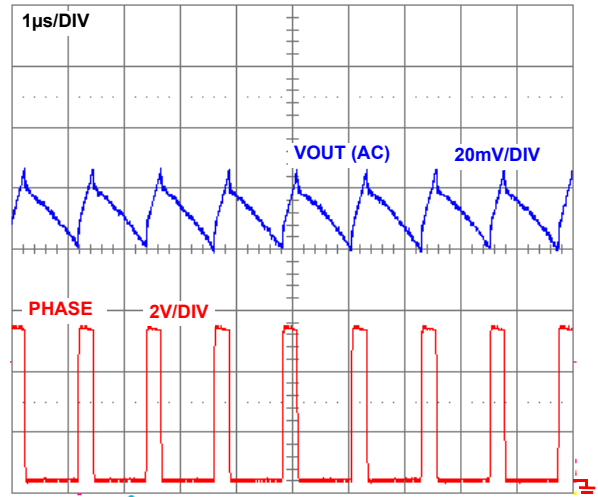

FIGURE 10. CCM STEADY-STATE

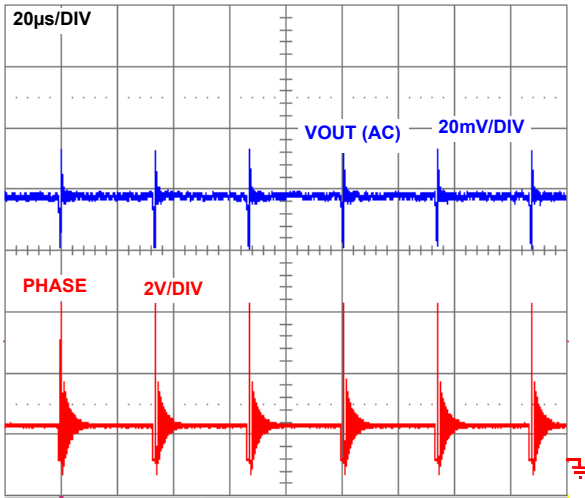

FIGURE 11. AUDIO MODE STEADY-STATE

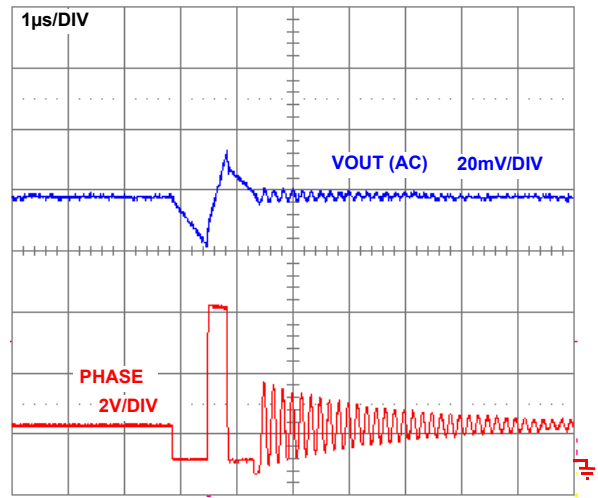

FIGURE 12. AUDIO MODE STEADY-STATE (ZOOM)

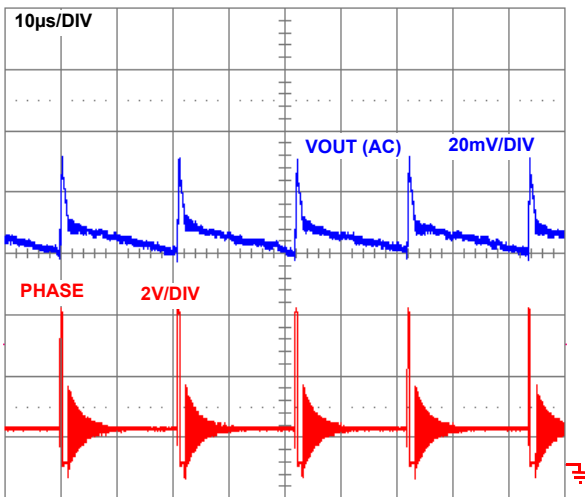

FIGURE 13. DCM STEADY-STATE (100mA)

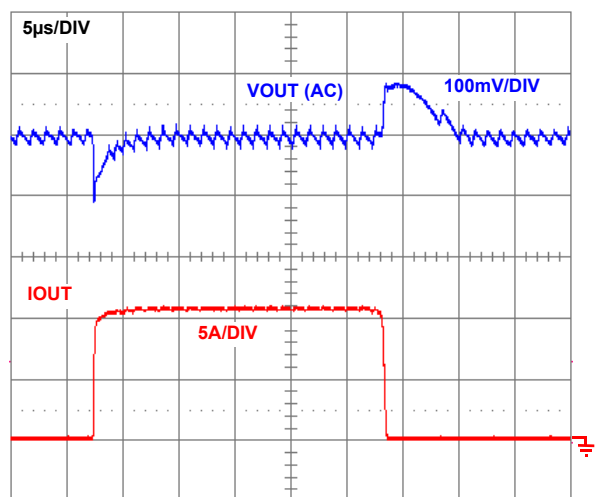

FIGURE 14. 10A LOAD TRANSIENT 50A/µs

Typical Performance Curves (Continued)

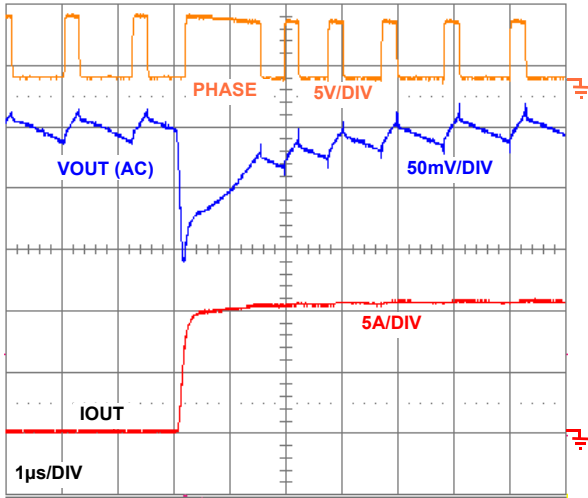

FIGURE 15. 10A LOAD TRANSIENT 50A/μs (ZOOM RISING EDGE)

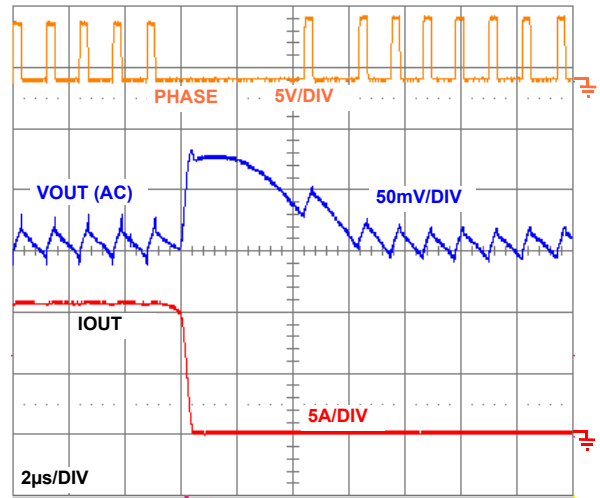

FIGURE 16. 10A LOAD TRANSIENT 50A/μs (ZOOM FALLING EDGE)

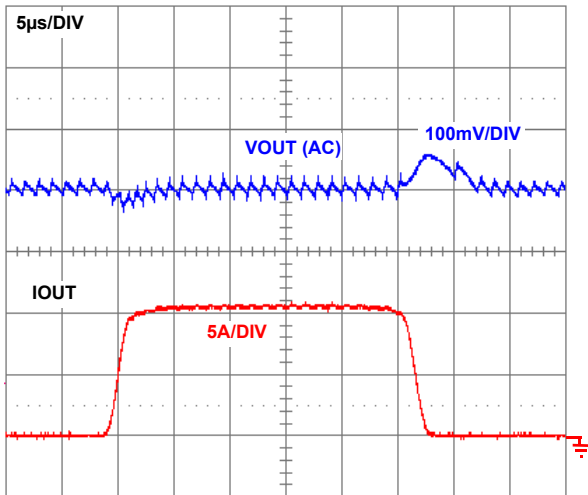

FIGURE 17. 10A LOAD TRANSIENT 5A/μs

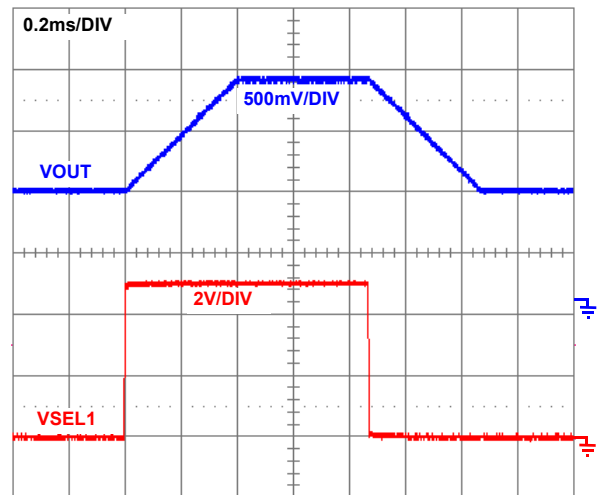

FIGURE 18. VSEL1 TRANSITIONS 0.90V TO 1.80V

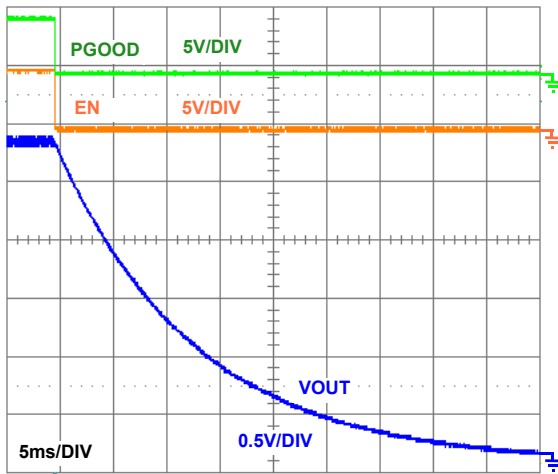

FIGURE 19. NORMAL SHUT-DOWN

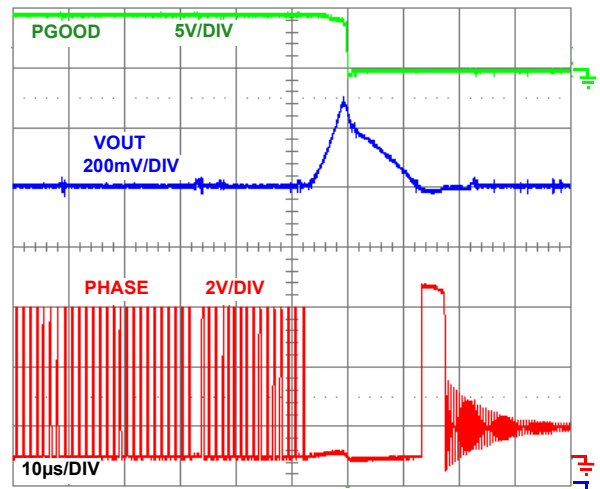

FIGURE 20. OVERVOLTAGE SHUT-DOWN (VDAC = 1.00V)

Typical Performance Curves (Continued)

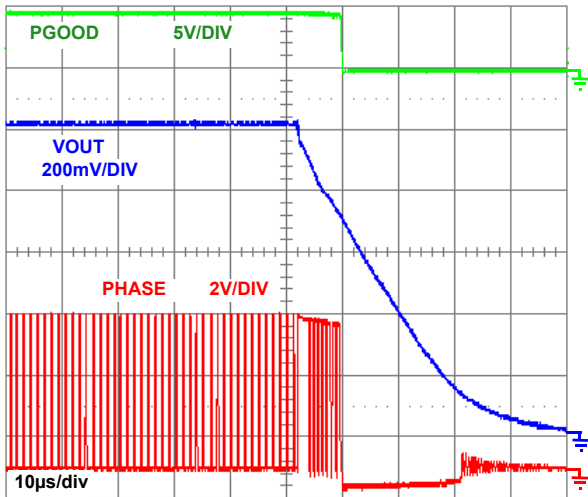

FIGURE 21. UNDERVOLTAGE SHUT-DOWN (VDAC = 1.00V)

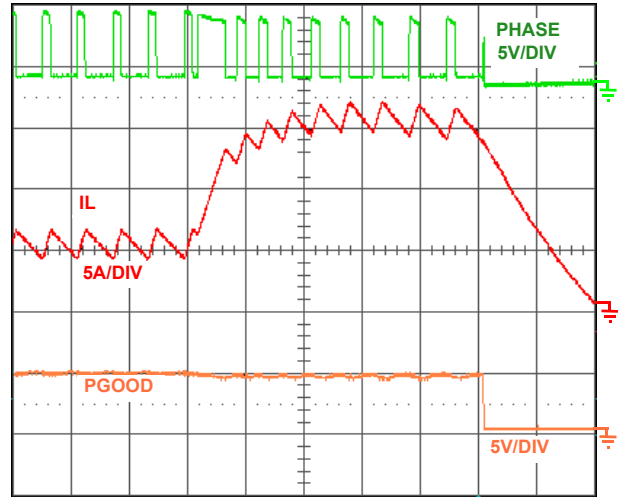

FIGURE 22. OVERCURRENT SHUTDOWN

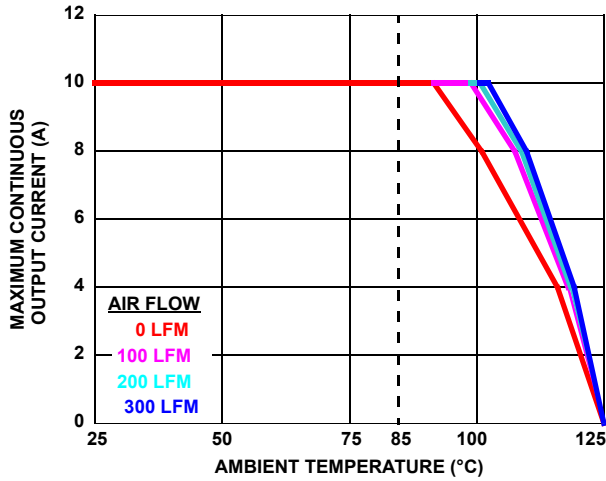

FIGURE 23. CURRENT DERATING OVER-TEMPERATURE

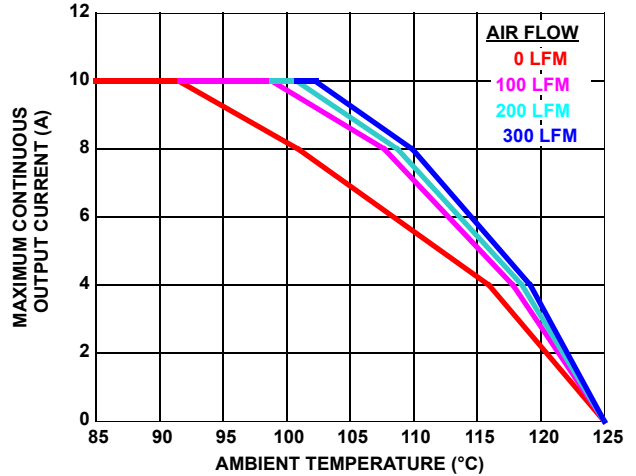

FIGURE 24. CURRENT DERATING OVER-TEMPERATURE (ZOOM)

NOTE: Figures 23 and 24 were generated on the ISL95210EVAL1Z REV B evaluation board (4-layers/2oz. copper). The test conditions were 5VIN and 1.8VOUT. The junction temperature was characterized by measuring the shift over-temperature of an integrated polysilicon resistor. All other above figures were generated with the typical application schematic found in Figure 1, unless otherwise specified. For more details on the layer stack up of the evaluation board, please see the ISL95210 Application Note ([AN1485](#)).

Theory of Operation

The following sections will provide a detailed description of the inner workings of the ISL95210 10A integrated FET regulator.

Start-Up

The ISL95210 will not respond to any logic inputs until VCC and PVCC are above the power-on reset (POR) level as described in the “Electrical Specifications” table on page 5. Once the POR condition is achieved, the ISL95210 will then acknowledge the states of its logic inputs. If the EN pin is pulled above the rising threshold, the regulator is commanded on and the soft-start sequence is initiated.

During soft-start, the programmed output voltage set point is determined by the logic states of VSEL0, VSEL1, MPCT and MSEL. The output then ramps digitally to the regulation voltage in 2.5mV/μs steps. Once the output voltage achieves regulation, the power-good monitor output (PGOOD) is toggled high to the voltage provided on the PG_IN pin. Figure 25 illustrates the ideal soft-start behavior.

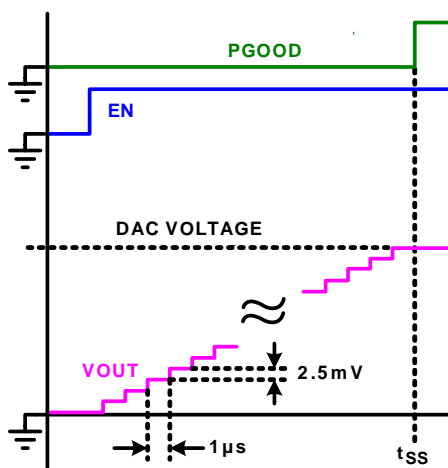

FIGURE 25. IDEALIZED SOFT-START WAVEFORM

Using the values in Tables 1 and 2, the soft-start interval can be easily calculated by Equation 1.

$$t_{SS} = \frac{V_{DAC}}{0.0025} \quad (\text{EQ. 1})$$

The units of Equation 1 are in microseconds. For example:

- VDAC = 1.200V
- $t_{SS} = 1.200V / 0.0025 = 480\mu s$

The fixed soft-start slew rate of 2.5mV/μs allows for easy calculation of the in-rush current.

$$I_{INRUSH} = (2500 \cdot C_{OUT}) \quad (\text{EQ. 2})$$

Consequently, the in-rush is manageable for all practical values of output capacitance. For example:

- COUT = 330μF
- Inrush Current = $2500 \cdot 330\mu F = 0.825A$

Output Voltage Programming

The highly integrated nature of the ISL95210 simplifies design and reduces component count. The VSEL0 and VSEL1 pins are 3-state logic inputs to an integrated DAC that controls the output voltage set point as prescribed in Table 1.

TABLE 1. DAC CONTROLLED OUTPUT VOLTAGE SETTINGS

VSEL1	VSEL0	VOUT (V)
0	0	0.600
0	FLOAT	0.750
0	1	0.900
FLOAT	0	1.000
FLOAT	FLOAT	1.050
FLOAT	1	1.100
1	0	1.200
1	FLOAT	1.500
1	1	1.800

NOTE: 1 = Input High, 0 = Input Low, FLOAT = Input unconnected or high-Z (see “Electrical Specifications” table for details).

This allows the user to program the output voltage without the use of a resistor divider network. However, if the user wishes to program values of VOUT away from the DAC values, a resistor divider can be used. However, because the input impedance of the VOUT pin is relatively low, the top resistor in the divider stack (R1 in Figure 31) **must** be kept small to minimize regulation error as the internal resistance changes over-temperature and process tolerances. A 100Ω resistor is recommended. The bottom resistor in the divider stack (R2 in Figure 31) can be derived from Equation 3:

$$R2 = \frac{R1 \cdot V_{DAC}}{V_{OUT} + \left(\frac{2 \cdot R1}{205k}\right) - \left(\frac{205k + R1}{205k}\right) \cdot V_{DAC}} \quad (\text{EQ. 3})$$

For example:

- Desired VOUT = 1.35V
- VDAC = 1.32V (1.2V +10% margin)
- R1 = 100Ω
- R2 = 4.351kΩ (select nearest standard value)

NOTE: The resistor divider should not be used to program VOUT more than 5% away from any preset DAC value. If this limit is exceeded, the modulator will be severely imbalanced and may result in loop instability and regulator shutdown.

The use of a resistor network also limits the soft discharge feature of the ISL95210. More detail on this operation can be found in the “Soft-Discharge” on page 15.

In addition to digitally controlled output voltage programming, the ISL95210 includes the ability to margin the output voltage up and down from the set point for use in end-of-line manufacturing reliability tests. The MPCT pin controls the amount of margining desired by the user and the MSEL pin determines when margining is engaged. In all margining conditions, the output voltage is slewed to the new value at the soft-start rate of

2.5mV/μs. Table 2 shows the output voltage as dictated by MPCT and MSEL.

TABLE 2. OUTPUT VOLTAGE MARGINING CONTROL

MSEL	MPCT	RESULT
0	0	NO MARGINING
0	FLOAT	NO MARGINING
0	1	NO MARGINING
FLOAT	0	MARGIN DOWN DAC - 15%
FLOAT	FLOAT	MARGIN DOWN DAC - 10%
FLOAT	1	MARGIN DOWN DAC - 20%
1	0	MARGIN UP DAC + 15%
1	FLOAT	MARGIN UP DAC + 10%
1	1	MARGIN UP DAC + 20%

NOTE: 1 = Input High, 0 = Input Low, FLOAT = Input unconnected or high-Z (see "Electrical Specifications" table for details).

Each of the margin targets represents the DAC code nearest to the desired value. Table 3 shows the actual targets for each margin setting (see Table 4 on page 17 for the full output truth table).

TABLE 3. OUTPUT VOLTAGE MARGIN TARGETS

VOUT	-20%	-15%	-10%	+10%	+15%	+20%
0.600	0.481	0.513	0.538	0.663	0.688	0.719
0.750	0.600	0.638	0.675	0.825	0.863	0.900
0.900	0.719	0.763	0.813	0.988	1.038	1.081
1.000	0.800	0.850	0.900	1.100	1.150	1.200
1.050	0.838	0.894	0.944	1.156	1.206	1.263
1.100	0.881	0.938	0.988	1.213	1.263	1.325
1.200	0.963	1.019	1.081	1.319	1.381	1.438
1.500	1.200	1.275	1.350	1.650	1.7250	1.800
1.800	1.438	1.531	1.619	1.981	2.069	2.163

Both the DAC and margining features can be used "on the fly", meaning the voltage can be changed during normal operation.

Regulation

R4™ MODULATOR

The R4 modulator is an advanced current-mode hysteretic control scheme that generates a synthetic current signal on chip instead of measuring real current. This has the benefit of producing a cleaner and lower jitter system versus conventional current-mode hysteretic architectures.

R4™ also employs a highly balanced architecture that greatly reduces the need for high DC loop gain traditionally required for output voltage regulation accuracy. This allows the R4™ modulator to accurately regulate without the need for an integrator in the feedback loop. Another benefit of the balanced system is that it does not require compensation for stability over a wide range of designs. The result is a power solution that is

flexible and easy to design with minimal components. A complete point of load regulator can be designed with the ISL95210 using only 4 external components.

Figure 26 shows the basic error-amplifier configuration for the R4™ controller. A hysteretic comparator monitors the synthetic current signal against the error voltage and corresponding window voltage to determine the PWM switching events.

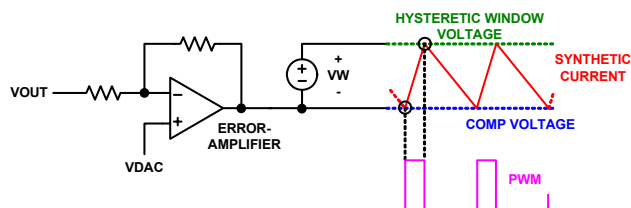

FIGURE 26. BASIC R4™ PWM SIGNAL GENERATION

STABILITY

The R4™ balanced architecture creates a control loop that does not require compensation for an extremely wide range of output filters (LOUT, COUT). However, there are corners of operation that will destabilize the loop and result in oscillatory behavior in VOUT.

The filters that push the control loop toward instability are ones that add a considerable amount of phase delay to the output voltage. In general, phase delay increases as output capacitance decreases in conjunction with reduced output capacitor equivalent series resistance (ESR). For this reason, output filters that are all-ceramic based have the most difficulty achieving stable regulation.

The first indication that the ISL95210 is nearing instability is when its step load response begins to have ring-back. Ring-back occurs when the PWM on pulse in response to a sharp increase in output load is so long as to cause the output voltage to overshoot the regulation point before fully recovering. Equation 4 approximates the boundary condition between normal recovery and ring-back as a function of operating parameters

$$[COUT \cdot ESR + K \cdot LOUT \cdot COUT] > ISTEP \cdot \frac{D \cdot \sqrt{D}}{FSW \cdot \Delta IL} \quad (EQ. 4)$$

where:

- COUT = Total output capacitance in Farads
- LOUT = Output inductance in Henries
- D = Steady-state duty cycle (VOUT / VIN)
- ESR = Output capacitor equivalent series resistance
- ISTEP = Expected load step (worst case is preferred)
- ΔIL = Inductor ripple current
- FSW = Switching frequency
- K = Modulator factor:
 - 3700 for 400kHz FSW
 - 4933 for 533kHz FSW
 - 7400 for 800kHz FSW

As good design practices dictate, a system should be designed safely away from this boundary to cover any tolerance shifts that may occur. For example, if the output capacitor in Figure 1 is replaced with low-ESR ceramics and reduced until the inequality

in Equation 4 is not met, transient ring-back performance similar to what is shown in Figure 27 will occur.

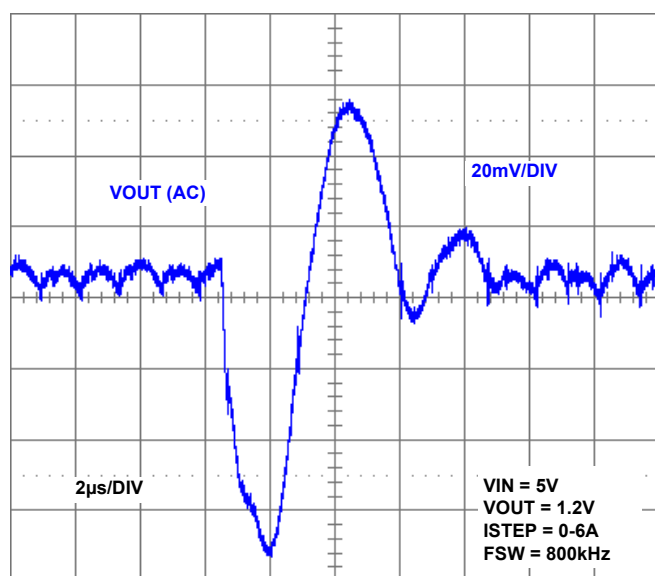

FIGURE 27. ISL95210 LOAD TRANSIENT RESPONSE WITH RING-BACK CONDITIONS FROM EXCESSIVE VOUT PHASE DELAY

In this example, the total output capacitance was 76µF with an ESR of approximately 1mΩ. When the values are put into Equation 4, the inequality is not met:

$$\times 3.12 \cdot 10^{-7} > 3.25 \cdot 10^{-7}$$

If additional ceramics are added to increase COUT to 120µF with an ESR of approximately 0.67mΩ, the ring-back condition is eliminated, providing the transient results seen in Figure 28.

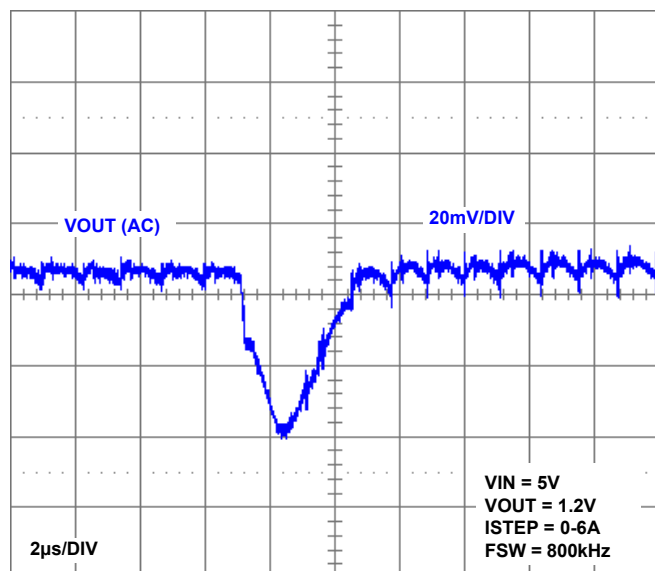

FIGURE 28. ISL95210 LOAD TRANSIENT RESPONSE WITHOUT RING-BACK CONDITIONS

When the new values are evaluated in Equation 4, the following results are observed:

$$\checkmark 4.53 \cdot 10^{-7} > 3.25 \cdot 10^{-7}$$

This result shows a clean, stable solution when the inequality is satisfied. It should be noted that when the capacitance in this example is decremented between 120µF and 76µF, the severity and frequency of ring-back increases. It can occur prior to violating Equation 4. This is due to the non-idealities that exist in real systems and some simplifications in the derivation process. Care should be taken to design away from the boundary condition. The above example became fully stable (zero ring-back) when the inequality's percentage difference was ~35%.

TRANSIENT RESPONSE

As with all current-mode hysteretic style controllers, the ISL95210 will increase and decrease switching frequency in response to load transient events. This oversampling quickens the converters response and minimizes output voltage deviation. The change in frequency is achieved by the movement on the COMP voltage seen in Figure 26. When the load current changes up or down, there is a proportional movement on COMP. The movement on COMP naturally changes the hysteretic window size for both PWM edges. Upward swings in COMP (due to increasing load current) make the effective hysteretic window larger during PWM on times and smaller during PWM off times. The result is increased switching frequency.

Conversely, downward swings in COMP (due to decreasing load current) make the effective hysteretic window smaller during PWM on times and larger during PWM off times. Switching frequency is reduced in this scenario. Figure 29 illustrates the idealized effect on switching frequency from movements in COMP in response to load transient events.

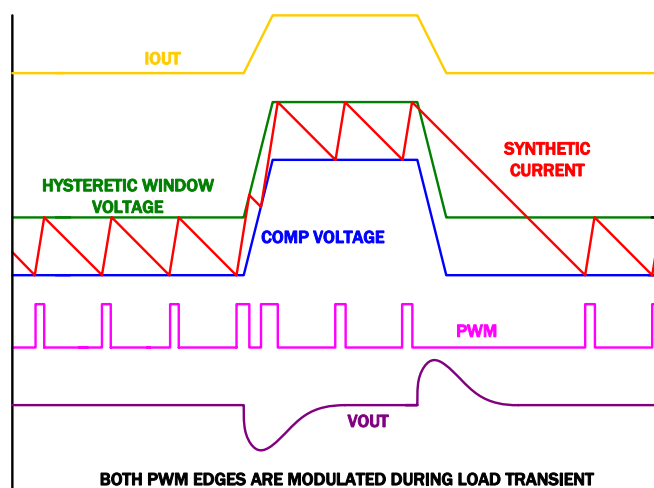

FIGURE 29. IDEALIZED EFFECT OF LOAD TRANSIENTS ON SWITCHING FREQUENCY

Unlike more traditional current-mode hysteretic architectures, R4™ does not require an error-integrating capacitor in the feedback loop. This removes significant delay in the control loop and produces extremely fast transient response to changes in load current.

The speed of response allows system designers to use less output capacitance and save on board area and cost.

Figure 30 depicts a comparison of the R4™ modulator vs. various classic architectures in response to a load step-up transient. The

dotted red and blue lines represent the time delayed behavior of VOUT and VCOMP when an integrator is used. The solid red and blue lines illustrate the increased response of R4™ in the absence of the integrating capacitor.

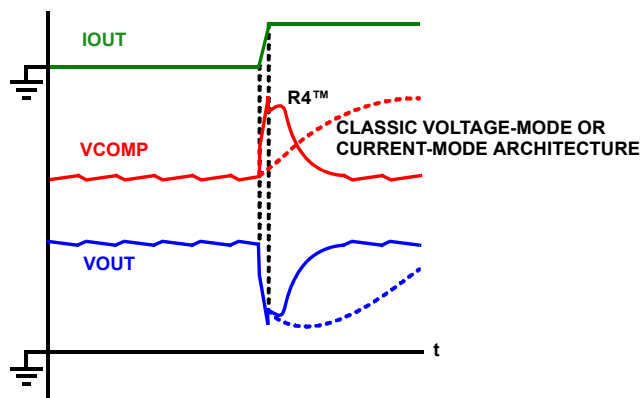

FIGURE 30. CLASSIC ARCHITECTURES vs R4™ IDEALIZED TRANSIENT RESPONSE

DISCONTINUOUS CONDUCTION MODES

The ISL95210 supports two power saving modes of operation during light load conditions. If FCCM is asserted high, the regulator remains in continuous conduction mode (CCM) which offers the best transient response and the most stable operating frequency.

If the FCCM pin is pulled to ground potential, the regulator is allowed to operate in full discontinuous conduction mode (DCM) when the load becomes sufficiently low. In this mode, the inductor current is monitored and prohibited from going negative. When the inductor current reaches zero, both internal power MOSFETs are turned off. The output voltage then decays solely as a function of load. The power FETs remain off until the output voltage droops enough to trigger a PWM on pulse. Because the rate of decay of VOUT scales proportionally with load, so does the switching frequency. This increases efficiency as the relatively fixed power loss associated with switching the power FETs is averaged over the switching period.

If the FCCM pin is left floating, the ISL95210 will operate in audio mode DCM. This mode operates largely the same as full DCM mode with one exception; the switching period is monitored cycle by cycle. If the load diminishes to a point where the switching frequency begins to drop below ~28kHz, the ISL95210 control loop will issue a PWM on pulse to ensure the frequency remains above the upper threshold for human hearing. This allows flexibility for designs that are sensitive to audio frequency interference.

The R4™ architecture seamlessly enters and exits all power saving modes to ensure accurate regulation.

Protection and Shutdown Features

The ISL95210 offers a full suite of protection features to reduce the risk of damage to the IC and load. They include under and overvoltage monitoring and protection as well as protection against excessive current and thermal operating conditions.

UNDERVOLTAGE PROTECTION

If the output voltage dips too low during normal operation, the ISL95210 recognizes a fault condition and shuts down. When VOUT goes 16% below VDAC, the power-good monitor flags PGOOD low and tri-states the PHASE node by turning off both integrated power MOSFETs. In addition, the soft-discharge MOSFET is turned on to gently pull the output voltage to ground potential for the next restart.

The undervoltage fault remains latched until a POR event or EN is toggled.

OVERVOLTAGE PROTECTION

During normal operation, the output voltage is monitored at all times to ensure it does not exceed the set point by more than 16%. Excessively high voltages can cause failure to output capacitors as well as the load. If VOUT goes above 116% of DAC, the power-good monitor is flagged by toggling PGOOD low and the IC enters overvoltage protection mode.

In overvoltage protection mode, the upper P-Channel MOSFET is latched off until the fault is cleared. In addition, VOUT is compared against the reference DAC voltage. If VOUT is above DAC, the lower N-channel MOSFET is turned on to pull VOUT down. If VOUT falls below DAC, the lower N-Channel MOSFET is turned off. This process repeats until the fault condition is cleared through VCC/PVCC POR or a recycling of the EN pin. This produces a soft-crowbar action that can effectively pull the output away from dangerously high voltage levels without causing the negative voltage swings on VOUT that are present with full crowbar implementations of overvoltage protection.

OVERCURRENT PROTECTION

If the current draw from the load becomes too high during operation, the IC protects itself and the load by latching off. The overcurrent mechanism is implemented as a two-fold protection scheme.

The ISL95210 continuously monitors the lower N-channel MOSFET current. It stores the valley of the inductor current each cycle and compares it against the lower overcurrent protection (OCP) threshold of 11A nominally. If the OCP threshold is achieved for 8 consecutive PWM cycles, an overcurrent fault is detected and the IC is shutdown. In this event, power-good monitor flags PGOOD low and tri-states both switching power MOSFETs and turns on the soft-discharge FET. Inductor valley current is used to ensure that the minimum OCP threshold is above the maximum ISL95210's normal maximum load of 10A regardless of chosen inductor value.

In addition to valley current limit, the upper P-Channel MOSFET current is continuously monitored. If a catastrophic overcurrent event is encountered (e.g. short circuit on VOUT), the ISL95210 immediately responds to protect the output by latching both MOSFETs off and engaging the soft-discharge FET. The power-good monitor flags PGOOD low and the IC remains latched off until POR or EN is toggled.

THERMAL PROTECTION

The ISL95210 actively monitors the die temperature to protect against harmful thermal operating conditions. If the silicon temperature exceeds +150°C, the controller will suspend

operation and shut down until the IC junction temperature falls below +135°C. Once the temperature has fallen below the lower protection threshold, the IC will resume normal operation following a POR event or toggling of the EN input.

POWER-GOOD MONITOR

A status indicator is provided to inform the system whether or not the ISL95210 output voltage is in regulation or if a fault has occurred. If VCC and PVCC are above the POR threshold, the part is enabled, and no faults have been detected, PGOOD will toggle high.

The power-good monitor is a CMOS configuration (refer to the “Functional Block Diagram” on page 2). This allows the user to provide any voltage to indicate when power is good. The voltage provided on to the PG_IN pin will be used as the logic high value for PGOOD. This has the advantage over open-drain configurations of saving a pull-up resistor. A pull-up resistor on PGOOD can still be used if desired. In this configuration, the PG_IN pin needs to be floated.

SOFT-DISCHARGE

To ensure a known operating condition when the ISL95210 is in a standby state, the VOUT pin is actively discharged to PGND through an integrated 45Ω MOSFET. The MOSFET is commanded on if the EN pin is pulled low or if any of the previously mentioned fault conditions are achieved with the exception of overvoltage, which actively pulls down on VOUT as a matter of protection.

It should be noted that if an external resistor divider is used to program VOUT to values not found in the DAC table, the soft-discharge feature will be negatively impacted. Figure 31 illustrates this condition.

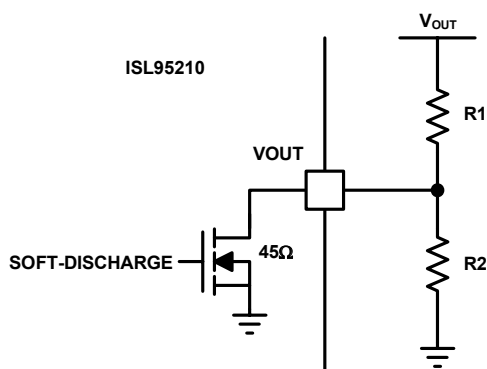

FIGURE 31. SIMPLIFIED SOFT-DISCHARGE CIRCUIT

The discharge resistance is increased by the presence of the resistor divider. The total discharge resistance is expressed in Equation 5:

$$R_{DCHRG} = \frac{45\Omega \cdot R2}{45\Omega + R2} + R1 \quad (\text{EQ. 5})$$

General Application Design Guide

This design guide is intended to provide a high-level explanation of the steps necessary to design a single-phase power converter. It is assumed that the reader is familiar with many of the basic skills

and techniques referenced in the following section. In addition to this guide, Intersil provides complete reference designs that include schematics, bills of materials, and example board layouts.

Selecting the LC Output Filter

The duty cycle of an ideal buck converter is a function of the input and the output voltage. This relationship is written as Equation 6:

$$D = \frac{V_O}{V_{IN}} \quad (\text{EQ. 6})$$

The output inductor peak-to-peak ripple current is written as Equation 7:

$$I_{PP} = \frac{V_O \cdot (1 - D)}{f_{SW} \cdot L} \quad (\text{EQ. 7})$$

A typical step-down DC/DC converter will have an $I_{P,P}$ of 20% to 40% of the maximum DC output load current. The value of $I_{P,P}$ is selected based upon several criteria such as MOSFET switching loss, inductor core loss, and the resistive loss of the inductor winding. The DC copper loss of the inductor can be estimated by Equation 8:

$$P_{COPPER} = I_{LOAD}^2 \cdot DCR \quad (\text{EQ. 8})$$

where I_{LOAD} is the converter output DC current.

The copper loss can be significant so attention has to be given to the DCR selection. Another factor to consider when choosing the inductor is its saturation characteristics at elevated temperature. A saturated inductor could cause destruction of circuit components, as well as nuisance OCP faults.

A DC/DC buck regulator must have output capacitance C_O into which ripple current $I_{P,P}$ can flow. Current $I_{P,P}$ develops a corresponding ripple voltage $V_{P,P}$ across C_O , which is the sum of the voltage drop across the capacitor ESR and of the voltage change stemming from charge moved in and out of the capacitor. These two voltages are written as Equation 9:

$$\Delta V_{ESR} = I_{P,P} \cdot ESR \quad (\text{EQ. 9})$$

and Equation 10:

$$\Delta V_C = \frac{I_{P,P}}{8 \cdot C_O \cdot F_{SW}} \quad (\text{EQ. 10})$$

If the output of the converter has to support a load with high pulsating current, several capacitors will need to be paralleled to reduce the total ESR until the required $V_{P,P}$ is achieved. The inductance of the capacitor can cause a brief voltage dip if the load transient has an extremely high slew rate. Low inductance capacitors should be considered in this scenario. A capacitor dissipates heat as a function of RMS current and frequency. Be sure that $I_{P,P}$ is shared by a sufficient quantity of paralleled capacitors so that they operate below the maximum rated RMS current at F_{SW} . Take into account that the rated value of a capacitor can fade as much as 50% as the DC voltage across it increases.

Selection of the Input Capacitor

The important parameters for the bulk input capacitance are the voltage rating and the RMS current rating. For reliable operation, select bulk capacitors with voltage and current ratings above the maximum input voltage and capable of supplying the RMS current required by the switching circuit. Their voltage rating should be at least 1.25x greater than the maximum input voltage, while a voltage rating of 1.5x is a preferred rating. Figure 32 is a graph of the input RMS ripple current, normalized relative to output load current, as a function of duty cycle and is adjusted for a converter efficiency of 80%. The ripple current calculation is written as Equation 11:

$$I_{IN_RMS_NORMALIZED} = \sqrt{(D - D^2) + \left(D \cdot \frac{x^2}{12}\right)} \quad (\text{EQ. 11})$$

where:

- x is a multiplier (0 to 1) corresponding to the inductor peak-to-peak ripple amplitude expressed as a percentage of I_{MAX} (0% to 100%)
- D is the duty cycle that is adjusted to take into account the efficiency of the converter, which is written as Equation 12:

$$D = \frac{V_O}{V_{IN} \cdot \text{EFF}} \quad (\text{EQ. 12})$$

In addition to the bulk capacitance, some low ESL ceramic capacitance is recommended to decouple between the drain of the high-side MOSFET and the source of the low-side MOSFET.

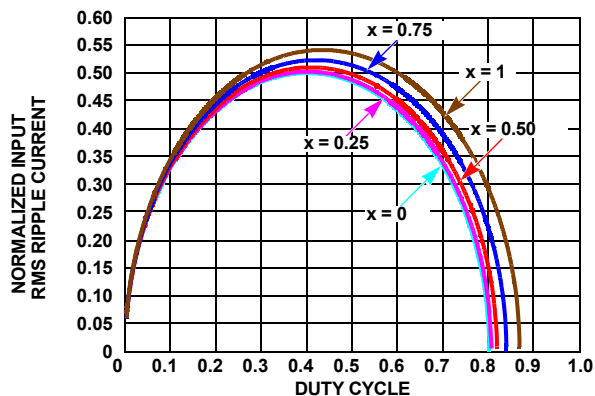

FIGURE 32. NORMALIZED RMS INPUT CURRENT

Typical Applications Circuits

There are two main variants to typical application schematic shown in Figure 1. The first of these is when an input voltage lower than 5V is desired. This requires the designer to provide separate power supplies to VIN and PVCC as the ISL95210 requires a 5V bias to operate properly. Figure 33 illustrates this configuration for a VIN of 3.3V.

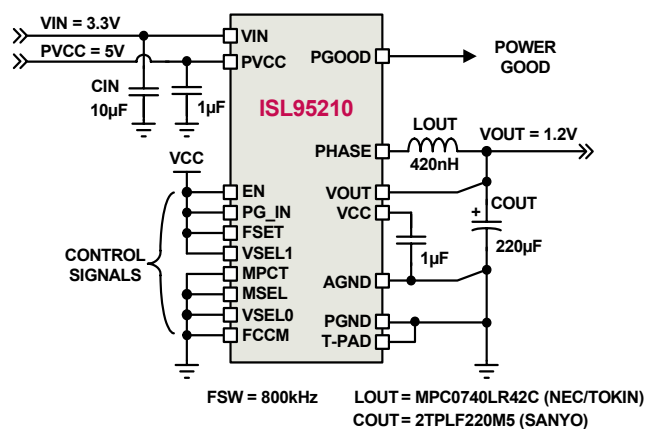

FIGURE 33. ISL95210 TYPICAL APPLICATION WITH VIN < 5V

The second typical application variant is when the designer wishes to program VOUT to a value not available in the DAC table. The component selection for this configuration is described in detail in “Output Voltage Programming” on page 11. Figure 34 shows a resistor divider programmed configuration for an output voltage of 2.25V.

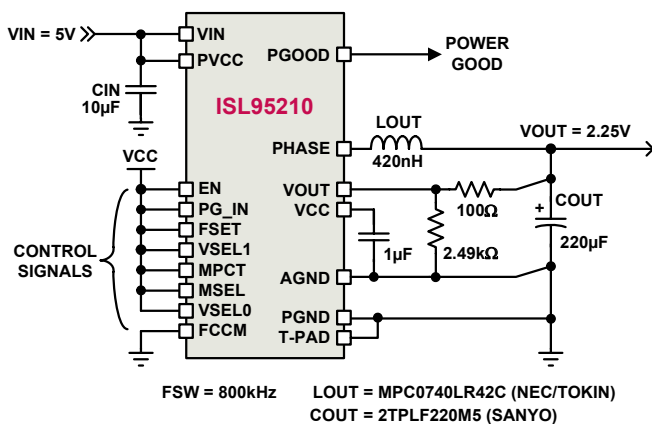

FIGURE 34. ISL95210 TYPICAL APPLICATION WITH VOUT = 2.5V

Layout Considerations

It is important to place power components as close as possible to the devices they decouple. Figure 35 provides an example of proper power component placement for the ISL95210. Input capacitors are placed directly across VIN and PGND to filter switching currents between the PMOS and NMOS power FETs. The output inductor is placed directly adjacent to the PHASE pins.

Its “north-south” arrangements easily allow for the output voltage decoupling capacitor to be placed with its ground terminal very near the input capacitors grounds and the PGND pins of the ISL95210. This provides a low impedance return path for the inductor ripple current. This is one possible arrangement that will result in a good layout.

The analog ground connection (not shown) should be connected directly to the ground plane through a via. The VCC decoupling capacitor should be placed next to the VCC and AGND pins for optimal noise rejection.

TABLE 4. OUTPUT VOLTAGE TRUTH TABLE (Continued)

MSEL	MPCT	VSEL1	VSELO	VOUT
0	1	FLOAT	1	1.10000
1	FLOAT	FLOAT	0	1.10000
1	0	FLOAT	0	1.15000
1	FLOAT	FLOAT	FLOAT	1.15625
0	0	1	0	1.20000
0	FLOAT	1	0	1.20000
0	1	1	0	1.20000
FLOAT	1	1	FLOAT	1.20000
1	1	FLOAT	0	1.20000
1	0	FLOAT	FLOAT	1.20625
1	FLOAT	FLOAT	1	1.21250
1	0	FLOAT	1	1.26250
1	1	FLOAT	FLOAT	1.26250
F	0	1	FLOAT	1.27500
1	FLOAT	1	0	1.31875
1	1	FLOAT	1	1.32500
FLOAT	FLOAT	1	FLOAT	1.35000
1	0	1	0	1.38125
FLOAT	1	1	1	1.43750
1	1	1	0	1.43750
0	0	1	FLOAT	1.50000
0	FLOAT	1	FLOAT	1.50000
0	1	1	FLOAT	1.50000
FLOAT	0	1	1	1.53125
FLOAT	FLOAT	1	1	1.61875
1	FLOAT	1	FLOAT	1.65000
1	0	1	FLOAT	1.72500
0	0	1	1	1.80000
0	FLOAT	1	1	1.80000
0	1	1	1	1.80000
1	1	1	FLOAT	1.80000
1	FLOAT	1	1	1.98125
1	0	1	1	2.06875
1	1	1	1	2.16250

NOTE: 1 = Input High, 0 = Input Low, FLOAT = Input unconnected or high-Z (see "Electrical Specifications" table for details).

ISL95210

Revision History

The revision history provided is for informational purposes only and is believed to be accurate, but not warranted. Please go to web to make sure you have the latest Rev.

DATE	REVISION	CHANGE
December 6, 2011	FN6938.4	In the "Recommended Operating Conditions" on page 5, changed the following from: VCC Supply Voltage.....41+5V ±10% VIN Supply Voltage.....+2.97V to +5V to: VCC Supply Voltage.....+5V ±10% VIN Supply Voltage.....+2.97V to +5.5V
November 1, 11	FN6938.3	"PG_OUT" pin renamed to "PGOOD." Multiple sections rewritten for clarity, specifically "Regulation" on page 12 to page 14.
May 18, 2011	FN6938.2	Added "32 Lead, 6mmx4mm QFN Package" to "Features" on page 1.
May 10, 2011	FN6938.1	Initial Release to web.

Products

Intersil Corporation is a leader in the design and manufacture of high-performance analog semiconductors. The Company's products address some of the industry's fastest growing markets, such as, flat panel displays, cell phones, handheld products, and notebooks. Intersil's product families address power management and analog signal processing functions. Go to www.intersil.com/products for a complete list of Intersil product families.

For a complete listing of Applications, Related Documentation and Related Parts, please see the respective device information page on intersil.com: [ISL95210](http://www.intersil.com/ISL95210)

To report errors or suggestions for this datasheet, please go to: www.intersil.com/askourstaff

FITs are available from our website at: <http://rel.intersil.com/reports/sear>

For additional products, see www.intersil.com/product_tree

Intersil products are manufactured, assembled and tested utilizing ISO9000 quality systems as noted in the quality certifications found at www.intersil.com/design/quality

Intersil products are sold by description only. Intersil Corporation reserves the right to make changes in circuit design, software and/or specifications at any time without notice. Accordingly, the reader is cautioned to verify that data sheets are current before placing orders. Information furnished by Intersil is believed to be accurate and reliable. However, no responsibility is assumed by Intersil or its subsidiaries for its use; nor for any infringements of patents or other rights of third parties which may result from its use. No license is granted by implication or otherwise under any patent or patent rights of Intersil or its subsidiaries.

For information regarding Intersil Corporation and its products, see www.intersil.com

Package Outline Drawing

L32.6x4B

32 LEAD QUAD FLAT NO-LEAD PLASTIC PACKAGE

Rev 0, 09/08

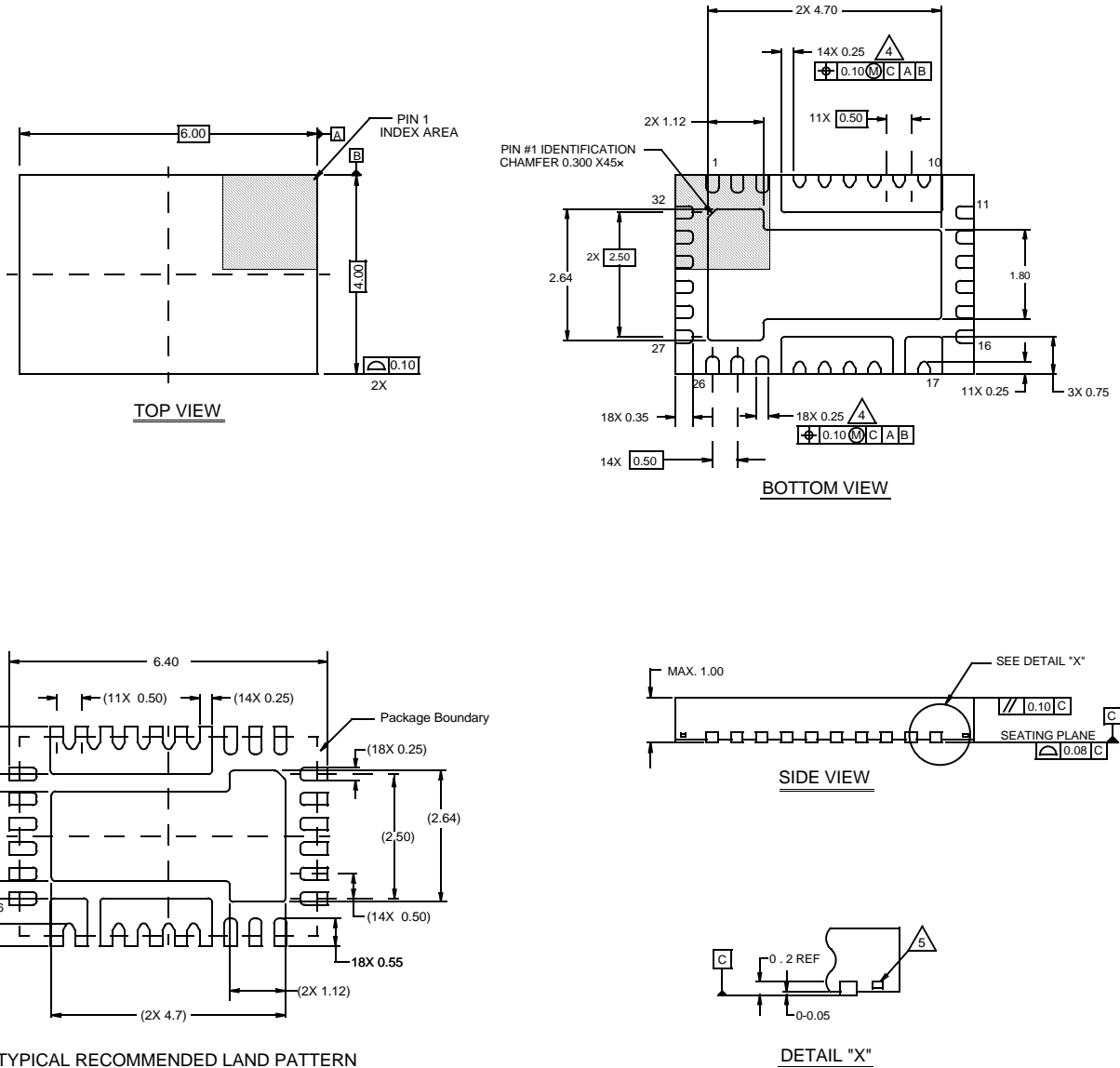

NOTES:

1. Dimensions are in millimeters.
Dimensions in () for Reference Only.
2. Dimensioning and tolerancing conform to AMSE Y14.5m-1994.
3. Unless otherwise specified, tolerance : Decimal ± 0.05
4. Dimension applies to the metallized terminal and is measured between 0.15mm and 0.30mm from the terminal tip.
5. Tiebar shown (if present) is a non-functional feature.
6. The configuration of the pin #1 identifier is optional, but must be located within the zone indicated. The pin #1 identifier may be either a mold or mark feature.