

3A Digital-DC Synchronous Step-Down DC/DC Converter

ZL2103

The ZL2103 is an innovative power conversion and management IC that combines an integrated synchronous step-down DC/DC converter with key power management functions in a small package, resulting in a flexible and integrated solution.

The ZL2103 can provide an output voltage from 0.54V to 5.5V (with margin) from an input voltage between 4.5V and 14V. Internal low $r_{DS(ON)}$ synchronous power MOSFETs enable the ZL2103 to deliver continuous loads up to 3A with high efficiency. An internal Schottky bootstrap diode reduces discrete component count. The ZL2103 also supports phase spreading to reduce system input capacitance.

Power management features such as digital soft-start delay and ramp, sequencing, tracking, and margining can be configured by simple pin-strapping or through an on-chip serial port. The ZL2103 uses the PMBus™ protocol for communication with a host controller and the Digital-DC bus for interoperability between other Zilker Labs devices.

Features

- Integrated MOSFET switches
- 3A continuous output current
- $\pm 1\%$ output voltage accuracy
- *Snapshot™* parametric capture
- I²C/SMBus interface, PMBus compatible
- Internal non-volatile memory (NVM)

Applications* (see page 27)

- Telecom, Networking, Storage equipment
- Test and Measurement equipment
- Industrial control equipment
- 5V and 12V distributed power systems

Related Literature

- See [AN2010](#) "Thermal and Layout Guidelines for Digital-DC™ Products"
- See [AN2033](#) "Zilker Labs PMBus Command Set-DDC Products PMBus Command Set"
- See [AN2035](#) "Compensation Using CompZL™"

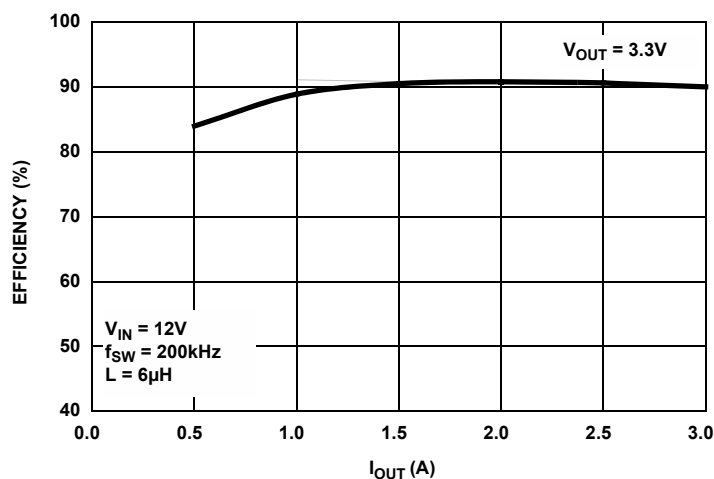
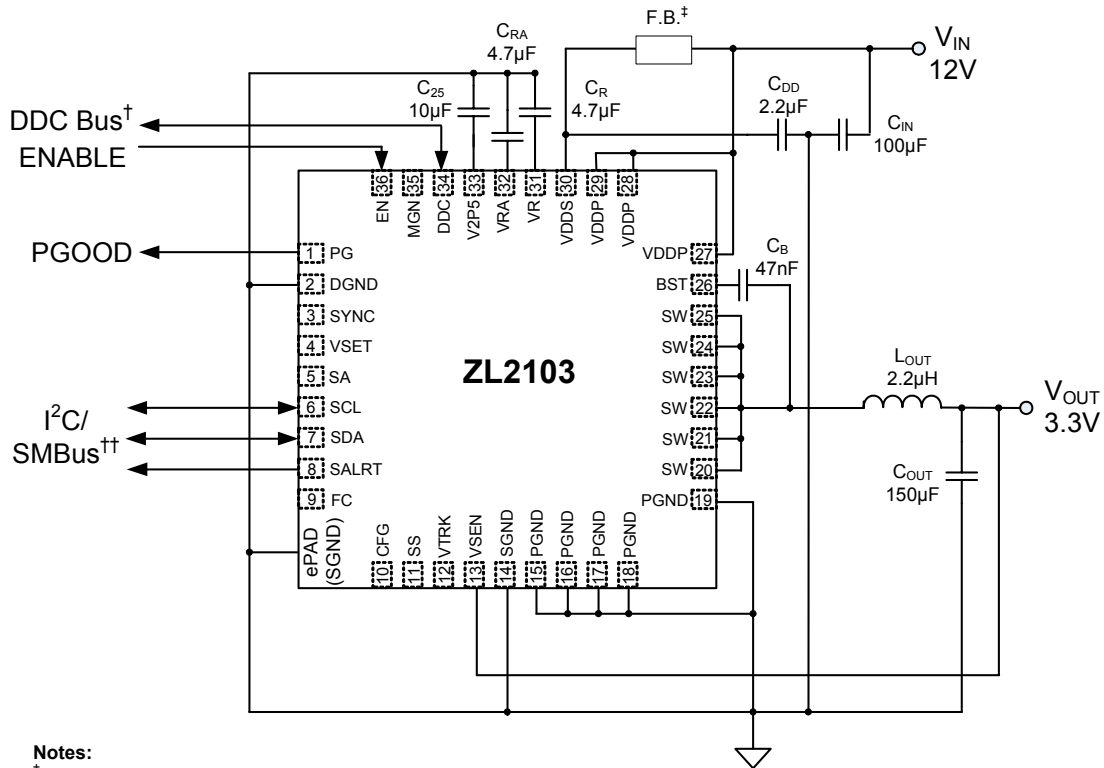

FIGURE 1. ZL2103 EFFICIENCY

ZL2103

Typical Application Circuit

The following application circuit represents a typical implementation of the ZL2103. For PMBus operation, it is recommended to tie the enable pin (EN) to SGND.



Notes:

‡ Ferrite bead is optional for input noise suppression.

† The DDC bus pull-up resistance will vary based on the capacitive loading of the bus, including the number of devices connected. The 10 kΩ default value, assuming a maximum of 100 pF per device, provides the necessary 1 µs pull-up rise time. Please refer to the Digital-DC Bus section for more details.

†† The I²C/SMBus pull-up resistance will vary based on the capacitive loading of the bus, including the number of devices connected. Please refer to the I²C/SMBus specifications for more details.

FIGURE 2. 12V TO 3.3V/3A APPLICATION CIRCUIT (5ms SS DELAY, 5ms SS RAMP)

Block Diagram

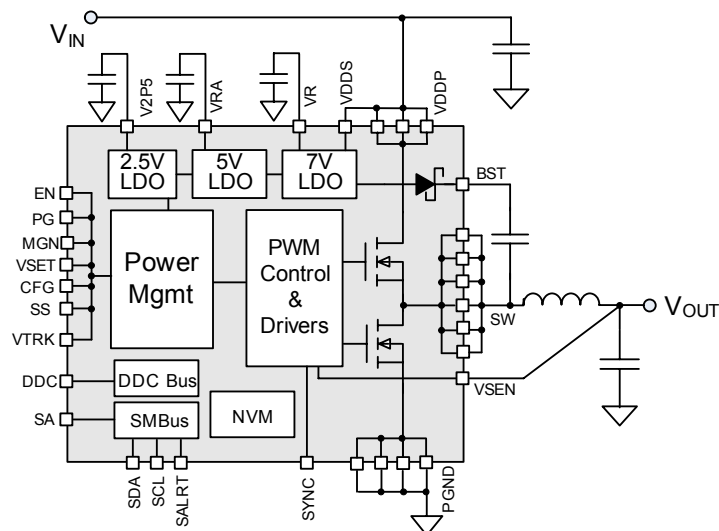

FIGURE 3. BLOCK DIAGRAM

ZL2103

Pin Configuration

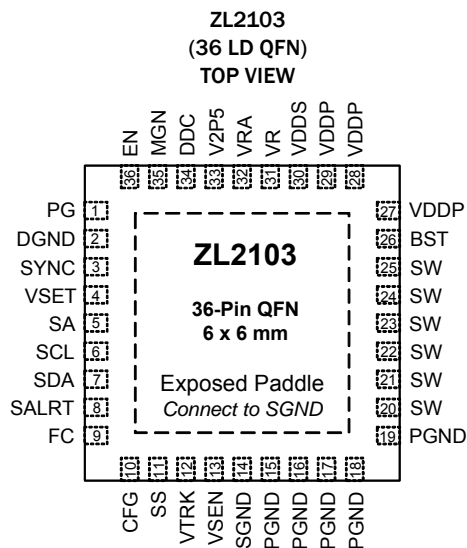

FIGURE 4.

Pin Descriptions

PIN	LABEL	TYPE (Note 1)	DESCRIPTION
1	PG	O	Power-good. This pin transitions high 100ms after output voltage stabilizes within regulation band. Selectable open drain or push-pull output. Factory default is open drain.
2	DGND	PWR	Digital ground. Common return for digital signals. Connect to low impedance ground plane.
3	SYNC	I/O, M (Note 2)	Clock synchronization pin. Used to set switching frequency of internal clock or for synchronization to external frequency reference.
4	VSET	I, M	Output voltage select pin. Used to set V_{OUT} set-point and V_{OUT} max.
5	SA	I, M	Serial address select pin. Used to assign unique SMBus address to each IC.
6	SCL	I/O	Serial clock. Connect to external host interface.
7	SDA	I/O	Serial data. Connect to external host interface.
8	SALRT	O	Serial alert. Connect to external host interface if desired.
9	FC	I, M	Loop compensation select pin. Used to set loop compensation.
10	CFG	I, M	Configuration pin. Used to control the SYNC pin, sequencing and enable tracking.
11	SS	I, M	Soft-start pin. Used to set the ramp delay and ramp time, sets UVLO and configure tracking.
12	VTRK	I	Track sense pin. Used to track an external voltage source.
13	VSEN	I	Output voltage positive feedback sensing pin.
14	SGND	PWR	Common return for analog signals. Connect to low impedance ground plane.
15, 16, 17, 18, 19	PGND	PWR	Power ground. Common return for internal switching MOSFETs. Connect to low impedance ground plane.
20, 21, 22, 23, 24, 25	SW	I/O	Switching node (level-shift common).
26	BST	PWR	Bootstrap voltage for level-shift driver (referenced to SW).
27, 28, 29	VDDP	PWR	Bias supply voltage for internal switching MOSFETs (return is PGND).
30	VDDS	PWR	IC supply voltage (return is SGND).

ZL2103

Pin Descriptions (Continued)

PIN	LABEL	TYPE (Note 1)	DESCRIPTION
31	VR	PWR	Regulated bias from internal 7V low-dropout regulator (return is PGND). Decouple with a 4.7 μ F capacitor to PGND.
32	VRA	PWR	Regulated bias from internal 5V low-dropout regulator for internal analog circuitry (return is SGND). Decouple with a 4.7 μ F capacitor to SGND.
33	V2P5	PWR	Regulated bias from internal 2.5V low-dropout regulator for internal digital circuitry (return is DGND). Decouple with a 10 μ F capacitor.
34	DDC	I/O	Digital-DC Bus (open drain). Interoperability between Zilker Labs devices.
35	MGN	I	Margin pin. Used to enable margining of the output voltage.
36	EN	I	Enable pin. Used to enable the device (active high).
ePad	SGND	PWR	Exposed thermal pad. Common return for analog signals. Connect to low impedance ground plane.

NOTES:

1. I = Input, O = Output, PWR = Power or Ground, M = Multi-mode pins. Please refer to Section "Multi-mode Pins" on page 12.
2. The SYNC pin can be used as a logic pin, a clock input or a clock output.

Ordering Information

PART NUMBER (Notes 4, 5)	PART MARKING	TEMP RANGE (°C)	PACKAGE (Pb-free)	PKG. DWG. #
ZL2103ALAF	2103	-40 to +85	36 Ld 6mmx6mm QFN	L36.6x6C
ZL2103ALAFT (Note 3)	2103	-40 to +85	36 Ld 6mmx6mm QFN	L36.6x6C
ZL2103ALAF TK (Note 3)	2103	-40 to +85	36 Ld 6mmx6mm QFN	L36.6x6C
ZL2103EVAL1Z	Evaluation Board			

NOTES:

3. Please refer to [TB347](#) for details on reel specifications.
4. These Intersil Pb-free plastic packaged products employ special Pb-free material sets, molding compounds/die attach materials, and 100% matte tin plate plus anneal (e3 termination finish, which is RoHS compliant and compatible with both SnPb and Pb-free soldering operations). Intersil Pb-free products are MSL classified at Pb-free peak reflow temperatures that meet or exceed the Pb-free requirements of IPC/JEDEC J STD-020.
5. For Moisture Sensitivity Level (MSL), please see device information page for [ZL2103](#). For more information on MSL please see techbrief [TB363](#).

Table of Contents

Absolute Maximum Ratings	6
Thermal Information	6
Recommended Operating Conditions	6
Electrical Specifications	6
Typical Performance Curves	9
ZL2103 Overview	10
Digital-DC Architecture	10
Power Conversion Overview	10
Power Management Overview	12
Multi-mode Pins	12
Power Conversion Functional Description	13
Internal Bias Regulators and Input Supply Connections	13
High-side Driver Boost Circuit	13
Output Voltage Selection	13
Start-up Procedure	14
Soft-start Delay and Ramp Times	14
Power-good (PG)	16
Switching Frequency and PLL	16
Component Selection	17
Current Sensing and Current Limit Threshold Selection	19
Loop Compensation	19
Driver Dead-time Control	20
Power Management Functional Description	20
Input Undervoltage Lockout	20
Output Overvoltage Protection	20
Output Pre-Bias Protection	21
Output Overcurrent Protection	22
Thermal Overload Protection	22
Voltage Tracking	22
Voltage Margining	23
I ² C/SMBus Communications	24
I ² C/SMBus Device Address Selection	24
Digital-DC Bus	24
Phase Spreading	25
Output Sequencing	25
Fault Spreading	26
Monitoring via I ² C/SMBus	26
Snapshot™ Parametric Capture	26
Non-Volatile Memory and Device Security Features	26
Revision History	27
Products	27
Package Outline Drawing	28

ZL2103

Absolute Maximum Ratings

DC Supply Voltage for VDDP, VDDS Pins	-0.3V to 17V
High-Side Supply Voltage for BST Pin	-0.3V to 25V
High-Side Boost Voltage for BST - SW Pins	-0.3V to 8V
Internal MOSFET Reference for VR Pin	-0.3V to 8.5V
Internal Analog Reference for VRA Pin	-0.3V to 6.5V
Internal 2.5 V Reference for V2P5 Pin	-0.3V to 3V
Logic I/O Voltage for EN, CFG, DDC, FC, MGN, PG, SDA, SCL, SA, SALRT, SS, SYNC, VTRK, VSET, VSEN Pins	-0.3V to 6.5V
Ground Differential for DGND - SGND, PGND - SGND Pins	±0.3V
MOSFET Drive Reference Current for VR Pin Internal Bias Usage	20mA
Switch Node Current for SW Pin Peak (Sink Or Source)	5A
ESD Rating Human Body Model Machine Model	2kV 500V
Latch-up	Tested to JESD78

Thermal Information

Thermal Resistance (Typical) 36 Ld QFN (Notes 6, 7)	θ_{JA} (°C/W)	θ_{JC} (°C/W)
	28	1
Junction Temperature Range	-55°C to +150°C	
Storage Temperature Range	-55°C to +150°C	
Dissipation Limits (Note 8)		
$T_A = +25^\circ\text{C}$	3.5W	
$T_A = +55^\circ\text{C}$	2.5W	
$T_A = +85^\circ\text{C}$	1.4W	
Pb-Free Reflow Profile	see link below http://www.intersil.com/pbfree/Pb-FreeReflow.asp	

Recommended Operating Conditions

Input Supply Voltage Range, VDDP, VDDS (See Figure 13) VDDS tied to VR, VRA	4.5V to 5.5V
VDDS tied to VR, VRA Floating	5.5V to 7.5V
VR, VRA Floating	7.5V to 14V
Output Voltage Range, V_{OUT} (Note 9)	0.54V to 5.5V
Operating Junction Temperature Range, T_J	-40°C to +125°C

CAUTION: Do not operate at or near the maximum ratings listed for extended periods of time. Exposure to such conditions may adversely impact product reliability and result in failures not covered by warranty.

NOTES:

- θ_{JA} is measured in free air with the component mounted on a high effective thermal conductivity test board with "direct attach" features. See Tech Brief [TB379](#).
- For θ_{JC} , the "case temp" location is the center of the exposed metal pad on the package underside.
- Thermal impedance depends on layout.
- Includes margin limits.

Electrical Specifications $V_{DDP} = V_{DDS} = 12V$, $T_A = -40^\circ\text{C}$ to $+85^\circ\text{C}$ unless otherwise noted. (Note 10) Typical values are at $T_A = +25^\circ\text{C}$. **Boldface limits apply over the operating temperature range, -40°C to $+85^\circ\text{C}$.**

PARAMETER	CONDITIONS	MIN (Note 20)	TYP	MAX (Note 20)	UNIT
Input and Supply Characteristics					
I_{DD} Supply Current	$f_{SW} = 200\text{kHz}$, no load	-	11	20	mA
	$f_{SW} = 1\text{MHz}$, no load	-	15	30	mA
I_{DDS} Shutdown Current	EN = 0V, No I ² C/SMBus activity	-	0.6	1	mA
VR Reference Output Voltage	$V_{DD} > 8V$, $I_{VR} < 10\text{mA}$	6.5	7.0	7.5	V
VRA Reference Output Voltage	$V_{DD} > 5.5V$, $I_{VRA} < 20\text{mA}$	4.5	5.1	5.5	V
V2P5 Reference Output Voltage	$I_{V2P5} < 20\text{mA}$	2.25	2.5	2.75	V
Output Characteristics					
Output Current	I_{RMS} , Continuous	-	-	3	A
Output Voltage Adjustment Range (Note 11)	$V_{IN} > V_{OUT}$	0.6	-	5.0	V
Output Voltage Setpoint Resolution	Set using resistors	-	10	-	mV
	Set using I ² C/SMBus	-	±0.025	-	% FS (Note 12)
Vsen Output Voltage Accuracy	Includes line, load, temp	-1	-	1	%
Vsen Input Bias Current	VSEN = 5.5V	-	110	200	µA
Soft-start Delay Duration Range (Note 13)	Set using SS pin or resistor	2	-	20	ms
	Set using I ² C/SMBus	0.002	-	500	s

ZL2103

Electrical Specifications $V_{DDP} = V_{DDS} = 12V$, $T_A = -40^{\circ}C$ to $+85^{\circ}C$ unless otherwise noted. (Note 10) Typical values are at $T_A = +25^{\circ}C$. **Boldface limits apply over the operating temperature range, $-40^{\circ}C$ to $+85^{\circ}C$. (Continued)**

PARAMETER	CONDITIONS	MIN (Note 20)	TYP	MAX (Note 20)	UNIT
Soft-start Delay Duration Accuracy	Turn-on delay (precise mode) (Notes 13, 14)	-	± 0.25	-	ms
	Turn-on delay (normal mode) (Note 15)	-	-0.25/+4	-	ms
	Turn-off delay (Note 15)	-	-0.25/+4	-	ms
Soft-start Ramp Duration Range	Set using SS pin or resistor	2	-	20	ms
	Set using I ² C/SMBus	0	-	200	ms
Soft-start Ramp Duration Accuracy		-	100	-	μs
Logic Input/output Characteristics					
Logic Input Leakage Current	Digital pins	-250	-	250	nA
Logic input low, V_{IL}		-	-	0.8	V
Logic input OPEN (N/C)	Multi-mode logic pins	-	1.4	-	V
Logic Input High, V_{IH}		2.0	-	-	V
Logic Output Low, V_{OL}	$I_{OL} \leq 4mA$	-	-	0.4	V
Logic Output High, V_{OH}	$I_{OH} \geq -2mA$	2.25	-	-	V
Oscillator and Switching Characteristics					
Switch Node Current, I_{SW}	Peak (source or sink) (Note 16)	-	-	4.5	A
Switching Frequency Range		200	-	1000	kHz
Switching Frequency Set-point Accuracy	Predefined settings (Table 9)	-5	-	5	%
PWM Duty Cycle (max)	Factory default (Note 17)	-	-	95 (Note 18)	%
SYNC Pulse Width (min)		150	-	-	ns
Input Clock Frequency Drift Tolerance	External clock source	-13	-	13	%
$r_{DS(ON)}$ of High Side N-channel FETs	$I_{SW} = 3A$, $V_{GS} = 6.5V$	-	60	85	$m\Omega$
$r_{DS(ON)}$ of Low Side N-channel FETs	$I_{SW} = 3A$, $V_{GS} = 12V$	-	43	65	$m\Omega$
Tracking					
VTRK Input Bias Current	VTRK = 5.5V	-	110	200	μA
VTRK Tracking Ramp Accuracy	100% Tracking, $V_{OUT} - VTRK$	-100	-	100	mV
VTRK Regulation Accuracy	100% Tracking, $V_{OUT} - VTRK$	-1	-	1	%
Fault Protection Characteristics					
UVLO Threshold Range	Configurable via I ² C/SMBus	2.85	-	16	V
UVLO Set-point Accuracy		-150	-	150	mV
UVLO Hysteresis	Factory default	-	3	-	%
	Configurable via I ² C/SMBus	0	-	100	%
UVLO Delay		-	-	2.5	μs
Power-good V_{OUT} Threshold	Factory default	-	90	-	% V_{OUT}
Power-good V_{OUT} Hysteresis	Factory default	-	5	-	%
Power-good Delay	Using pin-strap or resistor	2	-	20	ms
	Configurable via I ² C/SMBus)	0	-	500	s

ZL2103

Electrical Specifications $V_{DDP} = V_{DDS} = 1.2V$, $T_A = -40^{\circ}C$ to $+85^{\circ}C$ unless otherwise noted. (Note 10) Typical values are at $T_A = +25^{\circ}C$. **Boldface limits apply over the operating temperature range, $-40^{\circ}C$ to $+85^{\circ}C$. (Continued)**

PARAMETER	CONDITIONS	MIN (Note 20)	TYP	MAX (Note 20)	UNIT
VSEN Undervoltage Threshold	Factory default	-	85	-	% V_{OUT}
	Configurable via I ² C/SMBus	0	-	110	% V_{OUT}
VSEN Overvoltage Threshold	Factory default	-	115	-	% V_{OUT}
	Configurable via I ² C/SMBus	0	-	115	% V_{OUT}
VSEN Undervoltage Hysteresis		-	5	-	% V_{OUT}
VSEN Undervoltage/Overvoltage Fault Response Time	Factory default	-	16	-	μs
	Configurable via I ² C/SMBus	5	-	60	μs
Peak Current Limit Threshold	Factory default	-	-	4.5	A
	Configurable via I ² C/SMBus	0.2	-	4.5	A
Current Limit Set-point Accuracy		-	± 10	-	% FS (Note 12)
Current Limit Protection Delay	Factory default	-	5	-	t_{SW} (Note 19)
	Configurable via I ² C/SMBus	1	-	32	t_{SW} (Note 19)
Thermal Protection Threshold (Junction Temperature)	Factory default	-	125	-	$^{\circ}C$
	Configurable via I ² C/SMBus	-40	-	125	$^{\circ}C$
Thermal Protection Hysteresis		-	15	-	$^{\circ}C$

NOTES:

- Refer to Safe Operating Area in Figure 8 and thermal design guidelines in AN2010.
- Does not include margin limits.
- Percentage of Full Scale (FS) with temperature compensation applied.
- The device requires a delay period following an enable signal and prior to ramping its output. Precise timing mode limits this delay period to approx 2ms, where in normal mode it may vary up to 4ms.
- Precise ramp timing mode is only valid when using EN pin to enable the device rather than PMBus enable. Precise ramp timing mode is automatically disabled for a self-enabled device (EN pin tied high).
- The devices may require up to a 4ms delay following the assertion of the enable signal (normal mode) or following the de-assertion of the enable signal. Precise mode requires Re-Enable delay = $T_{OFF} + T_{FALL} + 10\mu s$.
- Switch node current should not exceed I_{RMS} of 3A.
- Factory default is the initial value in firmware. The value can be changed via PMBus commands.
- Maximum duty cycle is limited by the equation $MAX_DUTY(\%) = [1 - (150 \times 10^{-9} \times f_{SW})] \times 100$ and not to exceed 95%.
- $t_{SW} = 1/f_{SW}$, where f_{SW} is the switching frequency.
- Compliance to datasheet limits is assured by one or more methods: production test, characterization and/or design.

Typical Performance Curves

For some applications, ZL2103 operating conditions (input voltage, output voltage, switching frequency, temperature) may require de-rating to remain within the Safe Operating Area (SOA). $V_{IN} = V_{DDP} = V_{DDS}$, $T_J = +125^\circ\text{C}$.

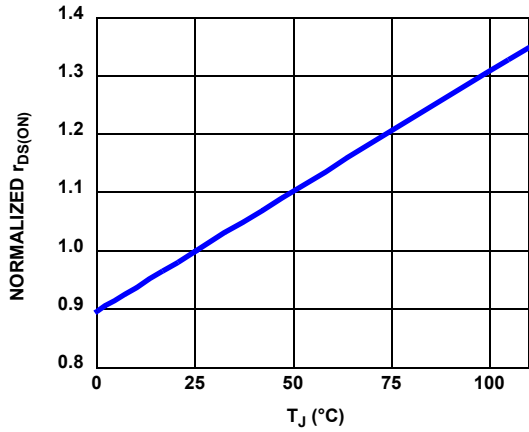

FIGURE 5. LOW-SIDE $r_{DS(ON)}$ vs T_J NORMALIZED FOR $T_J = +25^\circ\text{C}$ ($V_{DDS} = 12\text{V}$, $I_{DRAIN} = 0.3\text{A}$)

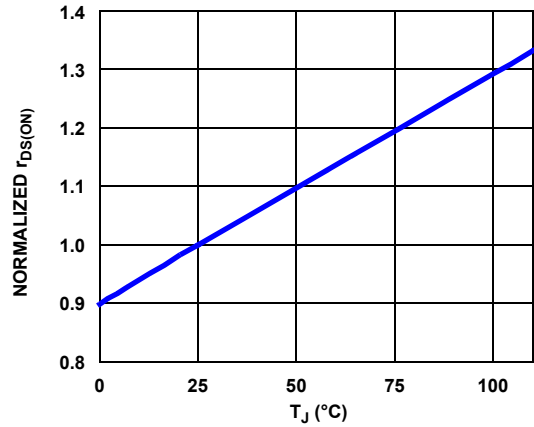

FIGURE 6. HIGH-SIDE $r_{DS(ON)}$ vs T_J NORMALIZED FOR $T_J = +25^\circ\text{C}$ ($V_{DDS} = 12\text{V}$, $BST - SW = 6.5\text{V}$, $I_{DRAIN} = 0.3\text{A}$)

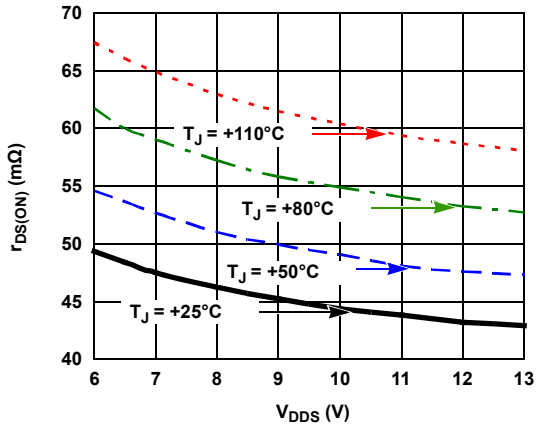

FIGURE 7. LOW-SIDE $r_{DS(ON)}$ vs V_{DD5} WITH T_J

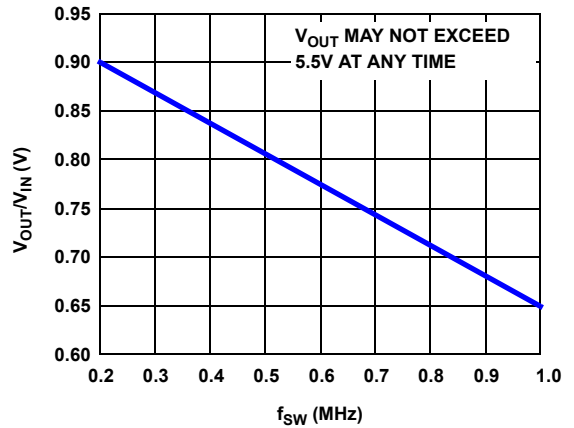

FIGURE 8. MAXIMUM CONVERSION RATIO, $T_J \leq +125^\circ\text{C}$

ZL2103 Overview

Digital-DC Architecture

The ZL2103 is an innovative mixed-signal power conversion and power management IC based on Zilker Labs patented Digital-DC technology that provides an integrated, high performance step-down converter for point of load applications. The ZL2103 integrates all necessary PWM control circuitry as well as low $r_{DS(ON)}$ synchronous power MOSFETs to provide an extremely small solution for supplying load currents up to 3A.

Its unique PWM loop utilizes an ideal mix of analog and digital blocks to enable precise control of the entire power conversion process with no software required, resulting in a very flexible device that is also very easy to use. An extensive set of power management functions are fully integrated and can be configured using simple pin connections. The user configuration can be saved in an internal non-volatile memory (NVM). Additionally, all functions can be configured and monitored via the SMBus hardware interface using standard PMBus commands, allowing ultimate flexibility.

Once enabled, the ZL2103 is immediately ready to regulate power and perform power management tasks with no programming required. Advanced configuration options and real-time configuration changes are available via the I²C/SMBus interface if desired and continuous monitoring of multiple operating parameters is possible with minimal interaction from a host controller. Integrated sub-regulation circuitry enables single supply operation from any external supply between 4.5V and 14V with no secondary bias supplies needed. The ZL2103 can also be configured to operate from a 3.3V or 5V standby supply when the main power rail is not present, allowing the user to configure and/or read diagnostic information from the device when the main power has been interrupted or is disabled.

The ZL2103 can be configured by simply connecting its pins according to the tables provided in the following sections. Additionally, a comprehensive set of application notes are available to help simplify the design process. An evaluation board is also available to help the user become familiar with the device. This board can be evaluated as a standalone platform using pin configuration settings. A Windows™-based GUI is also provided to enable full configuration and monitoring capability via the I²C/SMBus interface using an available computer and the included USB cable.

Power Conversion Overview

The ZL2103 operates as a voltage-mode, synchronous buck converter with a selectable constant frequency pulse width modulator (PWM) control scheme. The ZL2103 integrates dual low $r_{DS(ON)}$ synchronous MOSFETs to minimize the circuit footprint.

Figure 9 illustrates the basic synchronous buck converter topology showing the primary power train components. This converter is also called a step-down converter, as the output voltage must always be lower than the input voltage.

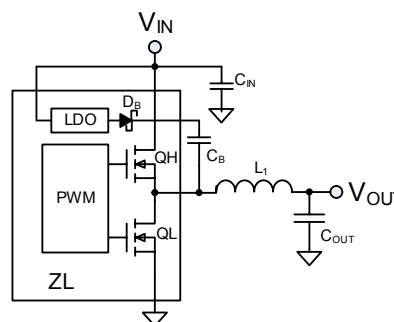

FIGURE 9. SYNCHRONOUS BUCK CONVERTER

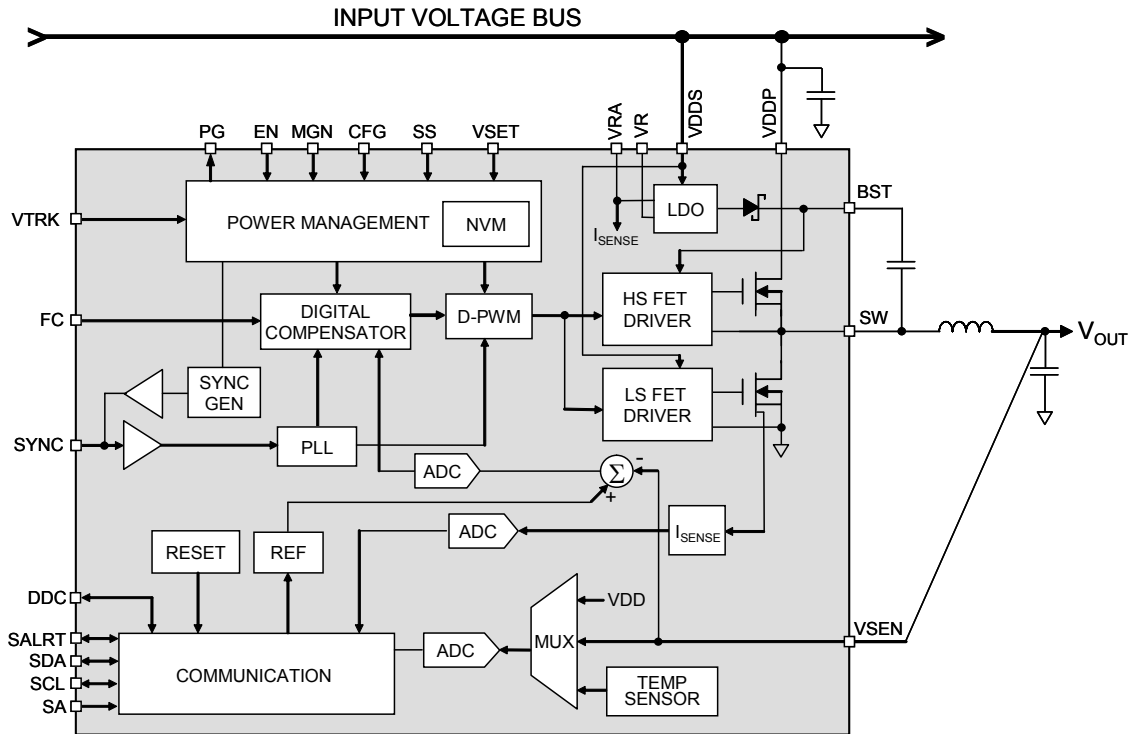

FIGURE 10. ZL2103 BLOCK DIAGRAM

The ZL2103 integrates two N-channel power MOSFETs; QH is the top control MOSFET and QL is the bottom synchronous MOSFET. The amount of time that QH is on as a fraction of the total switching period is known as the duty cycle D , which is described by Equation 1:

$$D \approx \frac{V_{OUT}}{V_{IN}} \quad (\text{EQ. 1})$$

During time D , QH is on and $V_{IN} - V_{OUT}$ is applied across the inductor. The output current ramps up as shown in Figure 11.

When QH turns off (time $1-D$), the current flowing in the inductor must continue to flow from the ground up through QL, during which the current ramps down. Since the output capacitor C_{OUT} exhibits low impedance at the switching frequency, the AC component of the inductor current is filtered from the output voltage so the load sees nearly a DC voltage.

The maximum conversion ratio is shown in Figure 9. Typically, buck converters specify a maximum duty cycle that effectively limits the maximum output voltage that can be realized for a given input voltage and switching frequency. This duty cycle limit ensures that the low-side MOSFET is allowed to turn on for a minimum amount of time during each switching cycle, which enables the bootstrap capacitor to be charged up and provide adequate gate drive voltage for the high-side MOSFET.

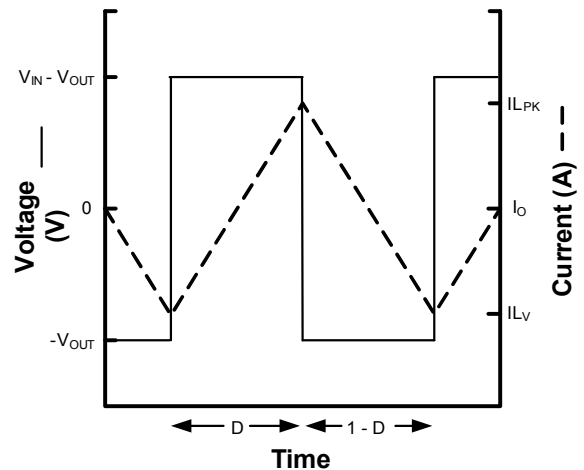

FIGURE 11. INDUCTOR WAVEFORM

In general, the size of components L_1 and C_{OUT} as well as the overall efficiency of the circuit are inversely proportional to the switching frequency, f_{SW} . Therefore, the highest efficiency circuit may be realized by switching the MOSFETs at the lowest possible frequency; however, this will result in the largest component size. Conversely, the smallest possible footprint may be realized by switching at the fastest possible frequency but this gives a somewhat lower efficiency. Each user should determine the optimal combination of size and efficiency when determining the switching frequency for each application.

The block diagram for the ZL2103 is illustrated in Figure 10. In this circuit, the target output voltage is regulated by connecting the VSEN pin directly to the output regulation point. The VSEN signal is then compared to an internal reference voltage that had been set to the desired output voltage level by the user. The error signal derived from this comparison is converted to a digital value with an analog to digital (A/D) converter. The digital signal is also applied to an adjustable digital compensation filter and the compensated signal is used to derive the appropriate PWM duty cycle for driving the internal MOSFETs in a way that produces the desired output.

Power Management Overview

The ZL2103 incorporates a wide range of configurable power management features that are simple to implement without additional components. Also, the ZL2103 includes circuit protection features that continuously safeguard the device and load from damage due to unexpected system faults. The ZL2103 can continuously monitor input voltage, output voltage/current and internal temperature. A Power-good output signal is also included to enable power-on reset functionality for an external processor.

All power management functions can be configured using either pin configuration techniques (see Figure 12) or via the I²C/SMBus interface. Monitoring parameters can also be pre-configured to provide alerts for specific conditions. See Application Note [AN2033](#) for more details on SMBus monitoring.

Multi-mode Pins

In order to simplify circuit design, the ZL2103 incorporates patented multi-mode pins that allow the user to easily configure many aspects of the device without programming. Most power management features can be configured using these pins. The multi-mode pins can respond to four different connections, as shown in Table 1. These pins are sampled when power is applied or by issuing a PMBus Restore command (see Application Note [AN2033](#)).

PIN-STRAP SETTINGS

This is the simplest method, as no additional components are required. Using this method, each pin can take on one of three possible states: LOW, OPEN, or HIGH. These pins can be connected to the V2P5 pin for logic HIGH settings as this pin provides a regulated voltage higher than 2V. Using a single pin one of three settings can be selected.

TABLE 1. MULTI-MODE PIN CONFIGURATION

PIN TIED TO	VALUE
LOW (Logic LOW)	< 0.8VDC
OPEN (N/C)	No connection
HIGH (Logic HIGH)	> 2.0VDC
Resistor to SGND	Set by resistor value

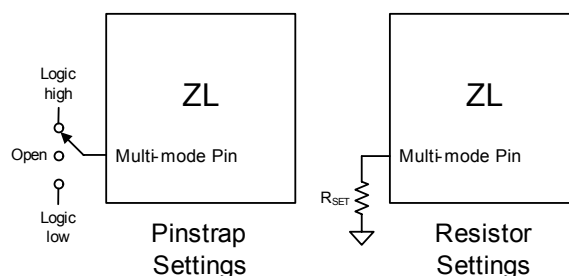

FIGURE 12. PIN-STRAP AND RESISTOR SETTING EXAMPLES

RESISTOR SETTINGS

This method allows a greater range of adjustability when connecting a finite value resistor (in a specified range) between the multi-mode pin and SGND.

Standard 1% resistor values are used, and only every fourth E96 resistor value is used so the device can reliably recognize the value of resistance connected to the pin while eliminating the error associated with the resistor accuracy. Up to 31 unique selections are available using a single resistor.

I²C/SMBUS METHOD

ZL2103 functions can be configured via the I²C/SMBus interface using standard PMBus commands. Additionally, any value that has been configured using the pin-strap or resistor setting methods can also be re-configured and/or verified via the I²C/SMBus. See Application Note [AN2033](#) for more details.

The SMBus device address and VOUT_MAX are the only parameters that must be set by external pins. All other device parameters can be set via the I²C/SMBus. The device address is set using the SA pin. VOUT_MAX is determined as 10% greater than the voltage set by the VSET pin.

Resistor pin-straps are recommended to be used for all available device parameters to allow a safe initial power-up before configuration is stored via the I²C/SMBus. For example, this can be accomplished by pin-strapping the undervoltage lockout threshold (using SS pin) to a value greater than the expected input voltage, thus preventing the device from enabling prior to loading a configuration file.

Power Conversion Functional Description

Internal Bias Regulators and Input Supply Connections

The ZL2103 employs three internal low dropout (LDO) regulators to supply bias voltages for internal circuitry, allowing it to operate from a single input supply. The internal bias regulators are as follows:

- **VR:** The VR LDO provides a regulated 7V bias supply for the high-side MOSFET driver circuit. It is powered from the VDDS pin and supplies bias current internally. A 4.7µF filter capacitor is required at the VR pin. The VDDS pin directly supplies the low-side MOSFET driver circuit.
- **VRA:** The VRA LDO provides a regulated 5V bias supply for the current sense circuit and other analog circuitry. It is powered from the VDDS pin and supplies bias current internally. A 4.7µF filter capacitor is required at the VRA pin.

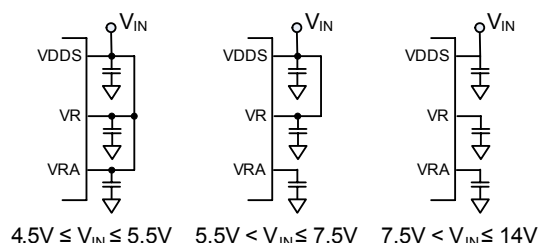

FIGURE 13. INPUT SUPPLY CONNECTIONS

- **V2P5:** The V2P5 LDO provides a regulated 2.5V bias supply for the main controller circuitry. It is powered from the VRA LDO and supplies bias current internally. A 10µF filter capacitor is required at the V2P5 pin.

When the input supply (VDDS) is higher than 7.5V, the VR and VRA pins should not be connected to any other pins. These pins should only have a filter capacitor attached. Due to the dropout voltage associated with the VR and VRA bias regulators, the VDDP pin must be connected to these pins for designs operating from a supply below 7.5V. Figure 13 illustrates the required connections for all cases.

Note: The internal bias regulators, VR and VRA, are not designed to be outputs for powering other circuitry. Do not attach external loads to any of these pins. Only the multi-mode pins may be connected to the V2P5 pin for logic HIGH settings.

High-side Driver Boost Circuit

The gate drive voltage for the high-side MOSFET driver is generated by a floating bootstrap capacitor, C_B (see Figure 9). When the lower MOSFET (QL) is turned on, the SW node is pulled to ground and the capacitor is charged from the internal VR bias regulator through diode D_B . When QL turns off and the upper MOSFET (QH) turns on, the SW node is pulled up to VDDP and the voltage on the bootstrap capacitor is boosted approximately 6.5V above VDDP to provide the necessary voltage to power the high-side driver. An internal Schottky diode is used with C_B to help maximize the high-side drive supply voltage.

Output Voltage Selection

The output voltage may be set to any voltage between 0.6V and 5.0V provided that the input voltage is higher than the desired output voltage by an amount sufficient to prevent the device from exceeding its maximum duty cycle specification. Using the pin-strap method, V_{OUT} can be set to one of three standard voltages as shown in Table 2.

TABLE 2. PIN-STRAP OUTPUT VOLTAGE SETTINGS

VSET	V_{OUT}
LOW	1.2V
OPEN	1.5V
HIGH	3.3V

TABLE 3. ZL2103 START-UP SEQUENCE

STEP #	STEP NAME	DESCRIPTION	TIME DURATION
1	Power Applied	Input voltage is applied to the ZL2103's VDD pins (VDDP and VDDS).	Depends on input supply ramp time
2	Internal Memory Check	The device will check for values stored in its internal memory. This step is also performed after a Restore command.	Approx 5ms to 10ms (device will ignore an enable signal or PMBus traffic during this period)
3	Multi-mode Pin Check	The device loads values configured by the multi-mode pins.	
4	Device Ready	The device is ready to accept an enable signal.	-
5	Pre-ramp Delay	The device requires approximately 2ms following an enable signal and prior to ramping its output. Additional pre-ramp delay may be configured using the SS pin.	Approximately 2ms

TABLE 4. RESISTORS FOR SETTING OUTPUT VOLTAGE

R _{SET} (kΩ)	V _{OUT} (V)
10	0.6
11	0.7
12.1	0.75
13.3	0.8
14.7	0.9
16.2	1.0
17.8	1.1
19.6	1.2
21.5	1.25
23.7	1.3
26.1	1.4
28.7	1.5
31.6	1.6
34.8	1.7
38.3	1.8
42.2	1.9
46.4	2.0
51.1	2.1
56.2	2.2
61.9	2.3
68.1	2.4
75	2.5
82.5	2.6
90.9	2.7
100	2.8
110	2.9
121	3.0
133	3.1
147	3.2
162	3.3
178	5.0

The resistor setting method can be used to set the output voltage to levels not available in Table 2. To set V_{OUT} using resistors, use Table 4 to select the resistor that corresponds to the desired voltage.

The output voltage may also be set to any value between 0.6V and 5.0V using the I²C interface. See Application Note [AN2033](#) for details.

Start-up Procedure

The ZL2103 follows a specific internal start-up procedure after power is applied to the VDD pins (VDDP and VDDS). Table 3 describes the start-up sequence.

If the device is to be synchronized to an external clock source, the clock frequency must be stable prior to asserting the EN pin. The device requires approximately 5ms to 10ms to check for specific values stored in its internal memory. If the user has stored values in memory, those values will be loaded. The device will then check the status of all multi-mode pins and load the values associated with the pin settings.

Once this process is completed, the device is ready to accept commands via the I²C/SMBus interface and the device is ready to be enabled. Once enabled, the device requires approximately 2ms before its output voltage may be allowed to start its ramp-up process. If a soft-start delay period less than 2ms has been configured (using PMBus commands), the device will default to a 2ms delay period. If a delay period greater than 2ms is configured, the device will wait for the configured delay period prior to starting to ramp its output.

After the delay period has expired, the output will begin to ramp towards its target voltage according to the pre-configured soft-start ramp time that has been set using the SS pin. It should be noted that if the EN pin is tied to VDDP or VDDS, the device will still require approximately 5ms to 10ms before the output can begin its ramp-up as described in Table 3.

Soft-start Delay and Ramp Times

It may be necessary to set a delay from when an enable signal is received until the output voltage starts to ramp to its target value. In addition, the designer may wish to set the time required for V_{OUT} to ramp to its target value after the delay period has expired. These features may be used as part of an overall inrush current management strategy or to control how fast a load IC is turned on. The ZL2103 gives the system designer several options for precisely and independently controlling both the delay and ramp time periods.

The soft-start delay period begins when the EN pin is asserted and ends when the delay time expires. The soft-start delay period is set using the SS pin. Precise ramp delay timing mode reduces the delay time variations and is available when the appropriate bit in the MISC_CONFIG register had been set. Please refer to Application Note [AN2033](#) for details.

The soft-start ramp timer enables a precisely controlled ramp to the nominal V_{OUT} value that begins once the delay period has expired. The ramp-up is guaranteed monotonic and its slope may be precisely set using the SS pin. Using the pin-strap method, the soft-start delay and ramp times can be set to one of three standard values according to Table 5.

TABLE 5. SOFT-START DELAY AND RAMP SETTINGS

SS PIN SETTING	DELAY AND RAMP TIME (ms)	UVLO
LOW	2	7.5V
OPEN	5	
HIGH	10	

If the desired soft-start delay and ramp times are not one of the values listed in Table 5, the times can be set to a custom value by connecting a resistor from the SS pin to SGND using the

ZL2103

appropriate resistor value from Table 6. The value of this resistor is measured upon start-up or Restore and will not change if the resistor is varied after power has been applied to the ZL2103 (see Figure 14).

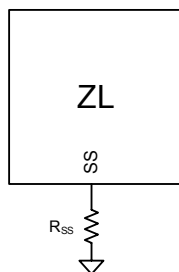

FIGURE 14. SS PIN RESISTOR CONNECTIONS

The soft-start delay and ramp times can also be set to custom values via the I²C/SMBus interface. When the SS delay time is set to 0ms, the device will begin its ramp-up after the internal circuitry has initialized (~2ms). When the soft-start ramp period is set to 0ms, the output will ramp up as quickly as the output load capacitance and loop settings will allow. It is generally recommended to set the soft-start ramp to a value greater than 500μs to prevent inadvertent fault conditions due to excessive inrush current.

TABLE 6. DELAY AND RAMP CONFIGURATION

R _{SS} (kΩ)	DELAY TIME (ms)	RAMP TIME (ms)	UVLO (V)
10	5	5	4.5
11	10		
12.1	20		
13.3	5	10	
14.7	10		
16.2	20		
17.8	5	2	5.5
19.6	10		
21.5	20		
23.7	5	5	
26.1	10		
28.7	20		
31.6	5	10	
34.8	10		
38.3	20		
42.2	5	20	
46.4	10		
51.1	20		
56.2	5	2	7.5
61.9	10		
68.1	20		
75	5	5	
82.5	10		
90.9	20		
100	5	10	
110	10		
121	20		
133	5	20	
147	10		
162	20		

Power-good (PG)

The ZL2103 provides a Power-good (PG) signal that indicates the output voltage is within a specified tolerance of its target level and no fault condition exists. By default, the PG pin will assert if the output is within +15%/-10% of the target voltage. These limits may be changed via the I²C/SMBus interface. See Application Note [AN2033](#) for details.

A PG delay period is the time from when all conditions for asserting PG are met and when the PG pin is actually asserted. This feature is commonly used instead of an external reset controller to signal the power supply is at its target voltage prior to enabling any powered circuitry. By default, the ZL2103 PG delay is set to 1ms and may be changed using the I²C/SMBus interface as described in [AN2033](#).

Switching Frequency and PLL

The ZL2103 incorporates an internal phase-locked loop (PLL) to clock the internal circuitry. The PLL can be driven by an external clock source connected to the SYNC pin. When using the internal oscillator, the SYNC pin can be configured as a clock source for other Zilker Labs devices.

The SYNC pin is a unique pin that can perform multiple functions depending on how it is configured. The CFG pin is used to select the operating mode of the SYNC pin as shown in Table 4. Figure 15 illustrates the typical connections for each mode.

TABLE 7. SYNC PIN FUNCTION SELECTION

CFG PIN	SYNC PIN FUNCTION
LOW	SYNC is configured as an input
OPEN	Auto detect mode
HIGH	SYNC is configured as an output $f_{sw} = 400kHz$

CONFIGURATION A: SYNC OUTPUT

When the SYNC pin is configured as an output (CFG pin is tied HIGH), the device will run from its internal oscillator and will drive the resulting internal oscillator signal (preset to 400kHz) onto the SYNC pin so other devices can be synchronized to it. The SYNC pin will not be checked for an incoming clock signal while in this mode.

CONFIGURATION B: SYNC INPUT

When the SYNC pin is configured as an input (CFG pin is tied LOW), the device will automatically check for an external clock signal on the SYNC pin each time the EN pin is asserted. The internal oscillator will then synchronize with the rising edge of the external clock. The incoming clock signal must be in the range of 200kHz to 1MHz with a minimum duty cycle and must be stable when the EN pin is asserted. The external clock signal must also exhibit the necessary performance requirements (see the “Electrical Specifications” table beginning on page 6).

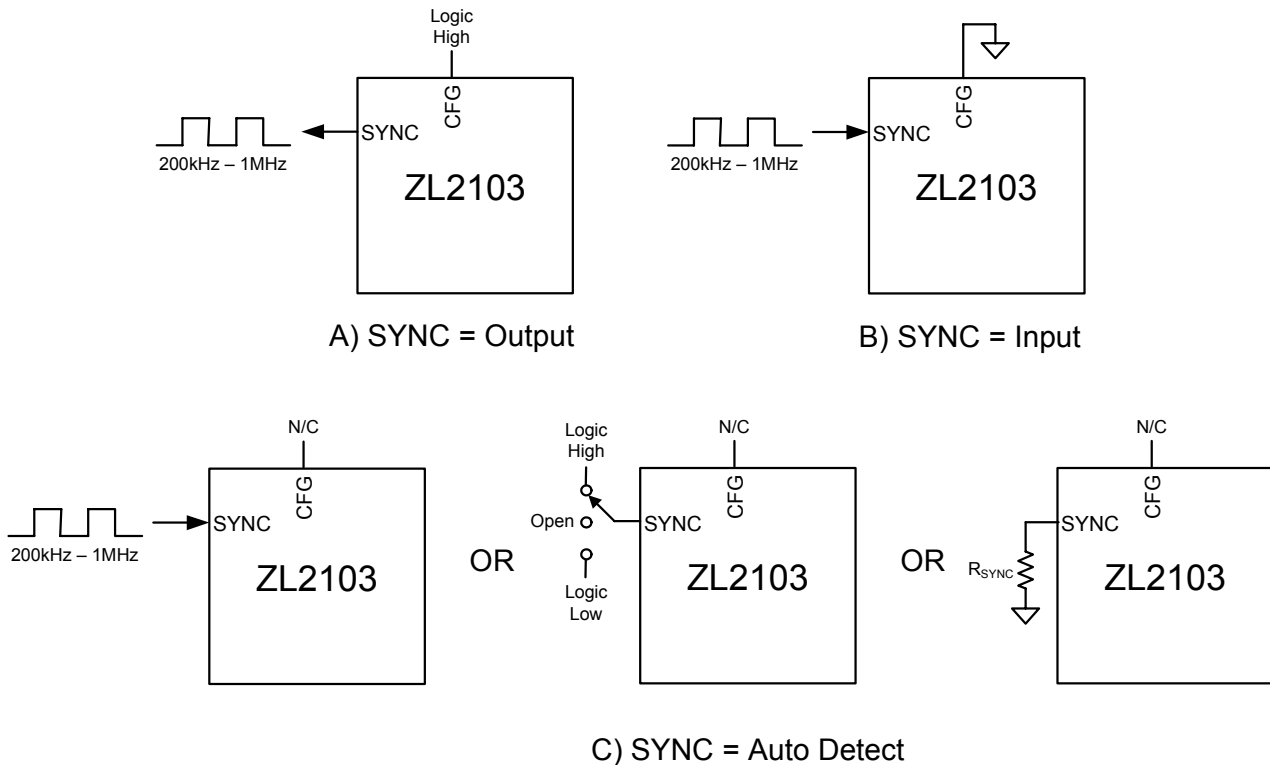

FIGURE 15. SYNC PIN CONFIGURATIONS

ZL2103

In the event of a loss of the external clock signal, the output voltage may show transient over/undershoot. If this happens, the ZL2103 will automatically switch to its internal oscillator and switch at a frequency close to the previous incoming frequency.

CONFIGURATION C: SYNC AUTO DETECT

When the SYNC pin is configured in auto detect mode (CFG pin is left OPEN), the device will automatically check for a clock signal on the SYNC pin after enable is asserted. If a valid clock signal is present, the ZL2103's oscillator will then synchronize with the rising edge of the external clock (refer to SYNC INPUT description).

If no incoming clock signal is present, the ZL2103 will configure the switching frequency according to the state of the SYNC pin as listed in Table 8. In this mode, the ZL2103 will only read the SYNC pin connection during the start-up sequence. Changes to the SYNC pin connection will not affect f_{SW} until the power (VDD5) is cycled off and on again.

TABLE 8. SWITCHING FREQUENCY SELECTION

SYNC PIN	FREQUENCY
LOW	200kHz
OPEN	400kHz
HIGH	1MHz
Resistor	See Table 9

If the user wishes to run the ZL2103 at a frequency not listed in Table 8, the switching frequency can be set using an external resistor, R_{SYNC} , connected between SYNC and SGND using Table 9.

TABLE 9. R_{SYNC} RESISTOR VALUES

R_{SYNC} (k Ω)	F_{SW} (kHz)
10	200
11	222
12.1	242
13.3	267
14.7	296
16.2	320
17.8	364
19.6	400
21.5	421
23.7	471
26.1	533
28.7	571
31.6	615
34.8	667
38.3	727
42.2	889
46.4	1000

The switching frequency can also be set to any value between 200kHz and 1MHz using the I²C/SMBus interface. The available frequencies are defined by $f_{SW} = 8MHz/N$, where whole number N is $8 \leq N \leq 40$. See Application Note [AN2033](#) for details.

If a value other than $f_{SW} = 8MHz/N$ is entered using a PMBus command, the internal circuitry will select the valid switching frequency value that is closest to the entered value. For example, if 810kHz is entered, the device will select 800kHz (N=10).

Note: The switching frequency read back using the appropriate PMBus command will differ slightly from the selected value in Table 9. The difference is due to hardware quantization.

When multiple Zilker Labs devices are used together, connecting the SYNC pins together will force all devices to synchronize with each other. The CFG pin of one device must set its SYNC pin as an output and the remaining devices must have their SYNC pins set as an input or as auto detect.

Note: Precise ramp timing I²C must be disabled to use SYNC clock auto detect.

Component Selection

The ZL2103 is a synchronous buck converter with integrated MOSFETs that uses an external inductor and capacitors to perform the power conversion process. The proper selection of the external components is critical for optimized performance.

To select the appropriate external components for the desired performance goals, the power supply requirements listed in Table 10 must be defined.

TABLE 10. POWER SUPPLY REQUIREMENTS

PARAMETER	RANGE	EXAMPLE VALUE
Input voltage (V_{IN})	4.5V to 14.0V	12V
Output voltage (V_{OUT})	0.6V to 5.0V	3.3V
Output current (I_{OUT})	0A to 3A	2A
Output voltage ripple (V_{orip})	< 3% of V_{OUT}	$\pm 1\%$ of V_{OUT}
Output load step (I_{ostep})	< I_o	$\pm 25\%$ of I_o
Output load step rate	-	2.5A/ μ s
Output deviation due to load step	-	$\pm 3\%$ of V_{OUT}
Maximum PCB temp.	+120 °C	+85 °C
Desired efficiency	-	85%
Other considerations	-	Optimize for small size

DESIGN GOAL TRADE-OFFS

The design of the buck power stage requires several compromises among size, efficiency and cost. The inductor core loss increases with frequency, so there is a trade-off between a

small output filter made possible by a higher switching frequency and getting better power supply efficiency. Size can be decreased by increasing the switching frequency at the expense of efficiency. Cost can be minimized by using through-hole inductors and capacitors; however these components are physically large.

To start the design, select a frequency based on Table 11. This frequency is a starting point and may be adjusted as the design progresses.

TABLE 11. CIRCUIT DESIGN CONSIDERATIONS

FREQUENCY RANGE	EFFICIENCY	CIRCUIT SIZE
200kHz to 400kHz	Highest	Larger
400kHz to 800kHz	Moderate	Smaller
800kHz to 1MHz	Lower	Smallest

INDUCTOR SELECTION

The output inductor selection process must include several trade-offs. A high inductance value will result in a low ripple current (I_{opp}), which will reduce output capacitance and produce a low output ripple voltage, but may also compromise output transient load performance. Therefore, a balance must be struck between output ripple and optimal load transient performance. A good starting point is to select the output inductor ripple equal to the expected load transient step magnitude (I_{ostep}):

$$I_{opp} = I_{ostep} \quad (\text{EQ. 2})$$

Now the output inductance can be calculated using Equation 3, where V_{INM} is the maximum input voltage:

$$L_{OUT} = \frac{V_{OUT} \times \left(1 - \frac{V_{OUT}}{V_{INM}}\right)}{f_{sw} \times I_{opp}} \quad (\text{EQ. 3})$$

The average inductor current is equal to the maximum output current. The peak inductor current (I_{Lpk}) is calculated using Equation 4 where I_{OUT} is the maximum output current:

$$I_{Lpk} = I_{OUT} + \frac{I_{opp}}{2} \quad (\text{EQ. 4})$$

Select an inductor rated for the average DC current with a peak current rating above the peak current computed in Equation 4.

In overcurrent or short-circuit conditions, the inductor may have currents greater than 2X the normal maximum rated output current. It is desirable to use an inductor that still provides some inductance to protect the load and the internal MOSFETs from damaging currents in this situation.

Once an inductor is selected, the DCR and core losses in the inductor are calculated. Use the DCR specified in the inductor manufacturer's data sheet.

$$P_{LDCR} = DCR \times I_{Lrms}^2 \quad (\text{EQ. 5})$$

I_{Lrms} is given by Equation 6:

$$I_{Lrms} = \sqrt{I_{OUT}^2 + \frac{(I_{opp})^2}{12}} \quad (\text{EQ. 6})$$

where I_{OUT} is the maximum output current. Next, calculate the core loss of the selected inductor. Since this calculation is specific to each inductor and manufacturer, refer to the chosen inductor data sheet. Add the core loss and the DCR loss and compare the total loss to the maximum power dissipation recommendation in the inductor data sheet.

OUTPUT CAPACITOR SELECTION

Several trade-offs must also be considered when selecting an output capacitor. Low ESR values are needed to have a small output deviation during transient load steps (V_{osag}) and low output voltage ripple (V_{orip}). However, capacitors with low ESR, such as semi-stable (X5R and X7R) dielectric ceramic capacitors, also have relatively low capacitance values. Many designs can use a combination of high capacitance devices and low ESR devices in parallel.

For high ripple currents, a low capacitance value can cause a significant amount of output voltage ripple. Likewise, in high transient load steps, a relatively large amount of capacitance is needed to minimize the output voltage deviation while the inductor current ramps up or down to the new steady state output current value.

As a starting point, apportion one-half of the output ripple voltage to the capacitor ESR and the other half to capacitance, as shown in Equations 7 and 8:

$$C_{OUT} = \frac{I_{opp}}{8 \times f_{sw} \times \frac{V_{orip}}{2}} \quad (\text{EQ. 7})$$

$$ESR = \frac{V_{orip}}{2 \times I_{opp}} \quad (\text{EQ. 8})$$

Use these values to make an initial capacitor selection, using a single capacitor or several capacitors in parallel.

After a capacitor has been selected, the resulting output voltage ripple can be calculated using Equation 9:

$$V_{orip} = I_{opp} \times ESR + \frac{I_{opp}}{8 \times f_{sw} \times C_{OUT}} \quad (\text{EQ. 9})$$

Because each part of this equation was made to be less than or equal to half of the allowed output ripple voltage, the V_{orip} should be less than the desired maximum output ripple.

INPUT CAPACITOR

It is highly recommended that dedicated input capacitors be used in any point-of-load design, even when the supply is powered from a heavily filtered 5V or 12V "bulk" supply from an off-line power supply. This is because of the high RMS ripple current that is drawn by the buck converter topology. This ripple (I_{CINrms}) can be determined from Equation 10:

$$I_{CINrms} = I_{OUT} \times \sqrt{D \times (1 - D)} \quad (\text{EQ. 10})$$

Without capacitive filtering near the power supply circuit, this current would flow through the supply bus and return planes, coupling noise into other system circuitry. The input capacitors should be rated at 1.2X the ripple current calculated in Equation 10 to avoid overheating of the capacitors due to the high ripple current, which can cause premature failure. Ceramic capacitors with X7R or X5R dielectric with low ESR and 1.1X the maximum expected input voltage are recommended.

BOOTSTRAP CAPACITOR SELECTION

The high-side driver boost circuit utilizes an internal Schottky diode (D_B) and an external bootstrap capacitor (C_B) to supply sufficient gate drive for the high-side MOSFET driver. C_B should be a 47nF ceramic type rated for at least 10V.

C_{V2P5} SELECTION

This capacitor is used to both stabilize and provide noise filtering for the 2.5V internal power supply. It should be between 4.7μF and 10μF, should use a semi-stable X5R or X7R dielectric ceramic with a low ESR (less than 10mΩ) and should have a rating of 4V or more.

C_{VR} SELECTION

This capacitor is used to both stabilize and provide noise filtering for the 7V reference supply. It should be between 4.7μF and 10μF, should use a semi-stable X5R or X7R dielectric ceramic capacitor with a low ESR (less than 10mΩ) and should have a rating of 10V or more. Because the current for the bootstrap supply is drawn from this capacitor, C_{VR} should be sized at least 10X the value of C_B so that a discharged C_B does not cause the voltage on it to droop excessively during a C_B recharge pulse.

C_{VRA} SELECTION

This capacitor is used to both stabilize and provide noise filtering for the analog 5V reference supply. It should be between 2.2μF and 10μF, should use a semi-stable X5R or X7R dielectric ceramic capacitor with a low ESR (less than 10mΩ) and should have a rating of 6.3V or more.

THERMAL CONSIDERATIONS

In typical applications, the ZL2103's high efficiency will limit the internal power dissipation inside the package. However, in applications that require a high ambient operating temperature the user must perform some thermal analysis to ensure that the ZL2103's maximum junction temperature is not exceeded.

The ZL2103 has a maximum junction temperature limit of +125°C, and the internal over-temperature limiting circuitry will force the device to shut down if its junction temperature exceeds this threshold. In order to calculate the maximum junction temperature, the user must first calculate the power dissipated inside the IC (P_Q) as expressed in Equation 11:

$$P_Q = (I_{LOAD}^2) [(R_{DS(ON)QH})(D) + (R_{DS(ON)QL})(1-D)] \quad (\text{EQ. 11})$$

The maximum operating junction temperature can then be calculated using Equation 12:

$$T_{jmax} = T_{PCB} + (P_Q \times \theta_{JC}) \quad (\text{EQ. 12})$$

Where T_{PCB} is the expected maximum printed circuit board temperature and θ_{JC} is the junction-to-case thermal resistance for the ZL2103 package.

Current Sensing and Current Limit Threshold Selection

The ZL2103 incorporates a patented "lossless" current sensing method across the internal low-side MOSFET that is independent of $r_{DS(ON)}$ variations, including temperature. The default value for the gain, which does not represent a $r_{DS(ON)}$ value, and the offset of the internal current sensing circuit can be modified by the IOUT_CAL_GAIN and IOUT_CAL_OFFSET commands.

The design should include a current limiting mechanism to protect the power supply from damage and prevent excessive current from being drawn from the input supply in the event that the output is shorted to ground or an overload condition is imposed on the output. Current limiting is accomplished by sensing the current through the circuit during a portion of the duty cycle. The current limit threshold is set to 4.5A by default. The current limit threshold can set to a custom value via the I²C/SMBus interface. Please refer to Application Note [AN2033](#) for further details.

Additionally, the ZL2103 gives the power supply designer several choices for the fault response during over or under current conditions. The user can select the number of violations allowed before declaring a fault, a blanking time and the action taken when a fault is detected. The blanking time represents the time when no current measurement is taken. This is to avoid taking a reading just after a current load step (less accurate due to potential ringing). Please refer to Application note [AN2033](#) for further details.

Loop Compensation

The ZL2103 operates as a voltage-mode synchronous buck controller with a fixed frequency PWM scheme. Although the ZL2103 uses a digital control loop, it operates much like a traditional analog PWM controller. Figure 16 is a simplified block diagram of the ZL2103 control loop, which differs from an analog control loop only by the constants in the PWM and compensation blocks. As in the analog controller case, the compensation block compares the output voltage to the desired voltage reference and compensation zeroes are added to keep the loop stable. The resulting integrated error signal is used to drive the PWM logic, converting the error signal to a duty cycle to drive the internal MOSFETs.

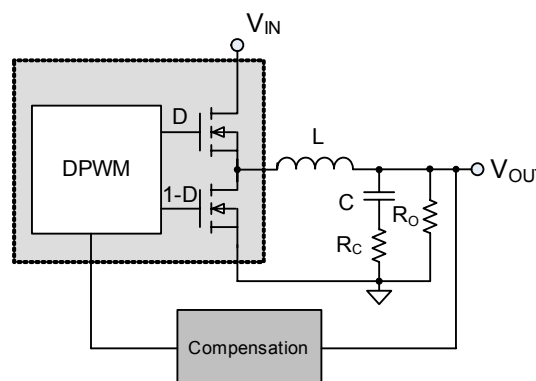

FIGURE 16. CONTROL LOOP BLOCK DIAGRAM

TABLE 12. RESISTOR SETTING FOR LOOP COMPENSATION

G _(dB)	Q	f _{sw} /f _n	FC (k)
24	0.150	115.000	Open or 11
27	0.150	115.000	Low or 10
27	0.150	69.147	13.3
27	0.150	41.577	14.7
27	0.300	115.000	16.2
27	0.300	69.147	17.8
27	0.300	41.577	19.6
27	0.300	25.000	21.5
27	0.600	69.147	23.7
27	0.600	41.577	26.1
27	0.600	25.000	28.7
30	0.150	115.000	High or 12.1
30	0.150	69.147	31.6
30	0.150	41.577	34.8
30	0.300	115.000	38.3
30	0.300	69.147	42.2
30	0.300	41.577	46.4
30	0.300	25.000	51.1
30	0.600	69.147	56.2
30	0.600	41.577	61.9
30	0.600	25.000	68.1
33	0.150	115.000	75.0
33	0.150	69.147	82.5
33	0.150	41.577	90.9
33	0.300	115.000	100.0
33	0.300	69.147	110.0
33	0.300	41.577	121.0
33	0.300	25.000	133.0
33	0.600	69.147	147.0
33	0.600	41.577	162.0
33	0.600	25.000	178.0

In the ZL2103, the compensation zeros are set by configuring the FC pin or via the I²C/SMBus interface once the user has calculated the required settings. This method eliminates the inaccuracies due to the component tolerances associated with using external resistors and capacitors required with traditional analog controllers.

The loop compensation coefficients can also be set via the I²C/SMBus interface. Please refer to Application Note [AN2033](#) for further details. Also refer to Application Note AN2035 for further technical details on setting loop compensation.

Driver Dead-time Control

The ZL2103 utilizes a predetermined fixed dead-time applied between the gate drive signals for the top and bottom MOSFETs.

In a synchronous buck converter, the MOSFET drive circuitry must be operated such that the top and bottom MOSFETs are never in

the conducting state at the same time. This is because potentially damaging currents flow in the circuit if both MOSFETs are on simultaneously for periods of time exceeding a few nanoseconds. Conversely, long periods of time in which both MOSFETs are off reduces overall circuit efficiency by allowing current to flow in their parasitic body diodes.

Therefore, it is advantageous to minimize the dead-time to provide peak optimal efficiency without compromising system reliability. The ZL2103 has optimized the dead-time for the integrated MOSFETs to maximizing efficiency.

Power Management Functional Description

Input Undervoltage Lockout

The input undervoltage lockout (UVLO) prevents the ZL2103 from operating when the input falls below a preset threshold, indicating the input supply is out of its specified range. The UVLO threshold (V_{UVLO}) can be set to either 4.5V or 10.8V using the SS pin according to Table 6.

The UVLO voltage can also be set to any value between 2.85V and 16V via the I²C/SMBus interface.

Once an input undervoltage fault condition occurs, the device can respond in a number of ways as follows:

1. Continue operating without interruption.
2. Continue operating for a given delay period, followed by shutdown if the fault still exists. The device will remain in shutdown until instructed to restart.
3. Initiate an immediate shutdown until the fault has been cleared. The user can select a specific number of retry attempts.

The default response from a UVLO fault is an immediate shutdown of the device. Please refer to Application Note [AN2033](#) for details on how to configure the UVLO threshold or to select specific UVLO fault response options via the I²C/SMBus interface.

Output Overvoltage Protection

The ZL2103 offers an internal output overvoltage protection circuit that can be used to protect sensitive load circuitry from being subjected to a voltage higher than its prescribed limits. A hardware comparator is used to compare the actual output voltage (seen at the VSEN pin) to a threshold set to 15% higher than the target output voltage (the default setting). If the VSEN voltage exceeds this threshold, the PG pin will de-assert and the device can then respond in a number of ways as follows:

1. Initiate an immediate shutdown until the fault has been cleared. The user can select a specific number of retry attempts.
2. Turn off the high-side MOSFET and turn on the low-side MOSFET. The low-side MOSFET remains on until the device attempts a restart.

The default response from an overvoltage fault is to immediately shut down. For continuous overvoltage protection when operating from an external clock, the only allowed response is an immediate shutdown. Please refer to Application Note [AN2033](#)

for details on how to select specific overvoltage fault response options via I²C/SMBus.

Output Pre-Bias Protection

An output pre-bias condition exists when an externally applied voltage is present on a power supply's output before the power supply's control IC is enabled. Certain applications require that the converter not be allowed to sink current during start up if a pre-bias condition exists at the output. The ZL2103 provides pre-bias protection by sampling the output voltage prior to initiating an output ramp.

If a pre-bias voltage lower than the target voltage exists after the pre-configured delay period has expired, the target voltage is set to match the existing pre-bias voltage and both drivers are enabled. The output voltage is then ramped to the final regulation value at the ramp rate set by the SS pin.

The actual time the output will take to ramp from the pre-bias voltage to the target voltage will vary depending on the pre-bias voltage but the total time elapsed from when the delay period expires and when the output reaches its target value will match the pre-configured ramp time (see Figure 17).

If a pre-bias voltage higher than the target voltage exists after the pre-configured delay period has expired, the target voltage is set to match the existing pre-bias voltage and both drivers are enabled with a PWM duty cycle that would ideally create the pre-bias voltage.

Once the pre-configured soft-start ramp period has expired, the PG pin will be asserted (assuming the pre-bias voltage is not higher than the overvoltage limit). The PWM will then adjust its duty cycle to match the original target voltage and the output will ramp down to the pre-configured output voltage.

If a pre-bias voltage higher than the overvoltage limit exists, the device will not initiate a turn-on sequence and will declare an overvoltage fault condition to exist. In this case, the device will respond based on the output overvoltage fault response method that has been selected. See "Output Overvoltage Protection" on page 20 for response options due to an overvoltage condition.

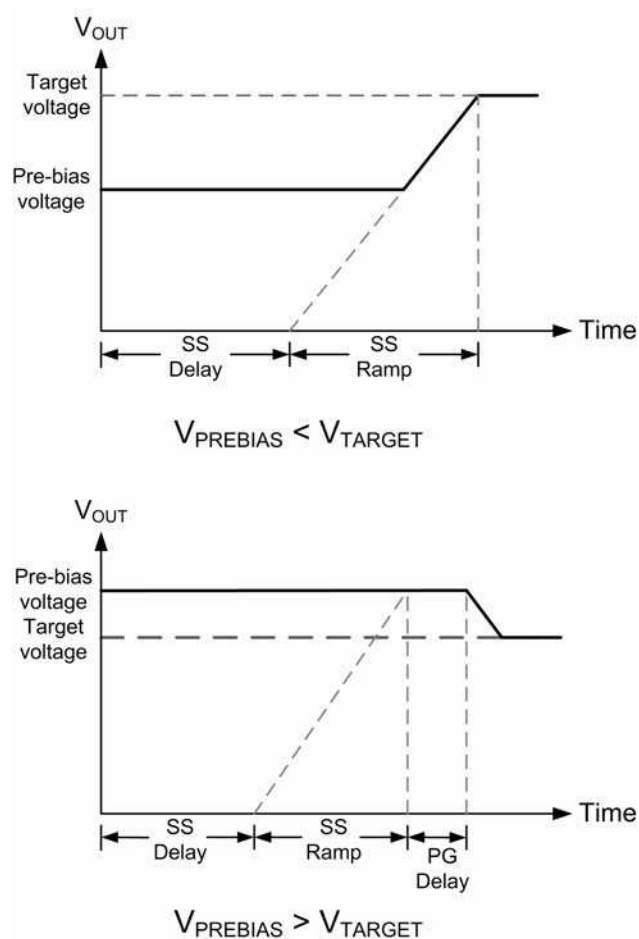

FIGURE 17. OUTPUT RESPONSES TO PRE-BIAS VOLTAGES

Output Overcurrent Protection

The ZL2103 can protect the power supply from damage if the output is shorted to ground or if an overload condition is imposed on the output. Once the current limit threshold has been selected (see “Current Sensing and Current Limit Threshold Selection” on page 19), the user may determine the desired course of action in response to the fault condition. The following overcurrent protection response options are available:

1. Initiate a shutdown and attempt to restart an infinite number of times with a preset delay period between attempts.
2. Initiate a shutdown and attempt to restart a preset number of times with a preset delay period between attempts.
3. Continue operating for a given delay period, followed by shutdown if the fault still exists.
4. Continue operating through the fault (this could result in permanent damage to the power supply).
5. Initiate an immediate shutdown.
6. The default response from an overcurrent fault is an immediate shutdown of the device. Please refer to Application Note [AN2033](#) for details on how to select specific overcurrent fault response options via I²C/SMBus.

Thermal Overload Protection

The ZL2103 includes an on-chip thermal sensor that continuously measures the internal temperature of the die and will shutdown the device when the temperature exceeds the preset limit. The factory default temperature limit is set to +125 °C, but the user may set the limit to a different value if desired. See Application Note [AN2033](#) for details. Note that setting a higher thermal limit via the I²C/SMBus interface may result in permanent damage to the device. Once the device has been disabled due to an internal temperature fault, the user may select one of several fault response options as follows:

1. Initiate a shutdown and attempt to restart an infinite number of times with a preset delay period between attempts.
2. Initiate a shutdown and attempt to restart a preset number of times with a preset delay period between attempts.
3. Continue operating for a given delay period, followed by shutdown if the fault still exists.
4. Continue operating through the fault (this could result in permanent damage to the power supply).
5. Initiate an immediate shutdown.

If the user has configured the device to restart, the device will wait the preset delay period (if configured to do so) and will then check the device temperature. If the temperature has dropped below a threshold that is approximately +15 °C lower than the selected temperature fault limit, the device will attempt to restart. If the temperature still exceeds the fault limit the device will wait the preset delay period and retry again.

The default response from a temperature fault is an immediate shutdown of the device. Please refer to Application Note [AN2033](#) for details on how to select specific temperature fault response options via I²C/SMBus.

Voltage Tracking

Numerous high performance systems place stringent demands on the order in which the power supply voltages are turned on. This is particularly true when powering FPGAs, ASICs, and other advanced processor devices that require multiple supply voltages to power a single die. In most cases, the I/O interface operates at a higher voltage than the core and therefore the core supply voltage must not exceed the I/O supply voltage according to the manufacturers' specifications.

Voltage tracking protects these sensitive ICs by limiting the differential voltage between multiple power supplies during the power-up and power down sequence. The ZL2103 integrates a lossless tracking scheme that allows its output to track a voltage that is applied to the VTRK pin with no additional components required. The VTRK pin is an analog input that, when tracking mode is enabled, configures the voltage applied to the VTRK pin to act as a reference for the device's output regulation.

The ZL2103 offers two modes of tracking. Figure 18 illustrates the output voltage waveform for the two tracking modes.

1. *Coincident*. This mode configures the ZL2103 to ramp its output voltage at the same rate as the voltage applied to the VTRK pin.
2. *Ratiometric*. This mode configures the ZL2103 to ramp its output voltage at a rate that is a percentage of the voltage applied to the VTRK pin. The default setting is 50%, but an external resistor may be used to configure a different tracking ratio.

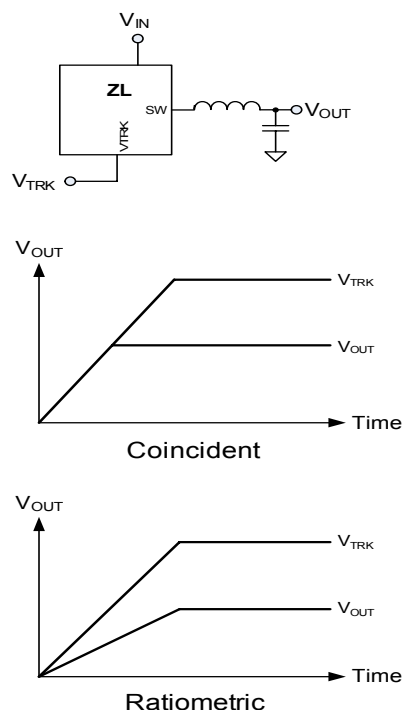

FIGURE 18. TRACKING MODES

The master device in a tracking group is defined as the device that has the highest target output voltage within the group. This master device will control the ramp rate of all tracking devices and is not configured for tracking mode. A delay of at least 10ms must be configured into the master device using the SS pin, and

ZL2103

the user may also configure a specific ramp rate using the SS pin. Tracking mode is enabled through the CFG pin, as shown in Table 16, and configured through the SS pin, as shown in Table 13.

Any device that is configured for tracking mode will ignore its soft-start delay and ramp time settings (SS pin) and its output will take on the turn-on/turn-off characteristics of the reference voltage present at the VTRK pin. All of the ENABLE pins in the tracking group must be connected together and driven by a single logic source.

Tracking mode can also be configured via the I²C/SMBus interface by using the TRACK_CONFIG PMBus command. Please refer to Application Note [AN2033](#) for more information on configuring tracking mode using PMBus.

Voltage Margining

The ZL2103 offers a simple means to vary its output higher or lower than its nominal voltage setting in order to determine whether the load device is capable of operating over its specified supply voltage range. The MGN command is set by driving the MGN pin or through the I²C/SMBus interface. The MGN pin is a tri-level input that is continuously monitored and can be driven directly by a processor I/O pin or other logic-level output.

The ZL2103's output will be forced higher than its nominal set point when the MGN command is set HIGH, and the output will be forced lower than its nominal set point when the MGN command is set LOW. Default margin limits of $V_{NOM} \pm 5\%$ are pre-loaded in the factory, but the margin limits can be modified through the I²C/SMBus interface to as high as $V_{NOM} + 10\%$ or as low as 0V, where V_{NOM} is the nominal output voltage set point determined by the VSET pin. A safety feature prevents the user from configuring the output voltage to exceed $V_{NOM} + 10\%$ under any conditions.

The margin limits and the MGN command can both be set individually through the I²C/SMBus interface. Additionally, the transition rate between the nominal output voltage and either margin limit can be configured through the I²C/SMBus interface. Please refer to Application Note [AN2033](#) for detailed instructions on modifying the margining configurations.

TABLE 13. TRACKING MODE CONFIGURATION

R _{SS} (kΩ)	UVLO (V)	TRACKING RATIO (%)	UPPER TRACK LIMIT	RAMP-UP/DOWN BEHAVIOR
19.6	5.5	100	Limited by target voltage	Output not allowed to decrease before PG
21.5				Output will always follow VTRK
23.7			Limited by VTRK pin voltage	Output not allowed to decrease before PG
26.1				Output will always follow VTRK
28.7		50	Limited by target voltage	Output not allowed to decrease before PG
31.6				Output will always follow VTRK
34.8			Limited by VTRK pin voltage	Output not allowed to decrease before PG
38.3				Output will always follow VTRK
56.2	7.5	100	Limited by target voltage	Output not allowed to decrease before PG
61.9				Output will always follow VTRK
68.1			Limited by VTRK pin voltage	Output not allowed to decrease before PG
75				Output will always follow VTRK
82.5		50	Limited by target voltage	Output not allowed to decrease before PG
90.9				Output will always follow VTRK
100			Limited by VTRK pin voltage	Output not allowed to decrease before PG
110				Output will always follow VTRK

I²C/SMBus Communications

The ZL2103 provides an I²C/SMBus digital interface that enables the user to configure all aspects of the device operation as well as monitor the input and output parameters. The ZL2103 can be used with any standard 2-wire I²C host device.

In addition, the device is compatible with SMBus version 2.0 and includes an SALRT line to help mitigate bandwidth limitations related to continuous fault monitoring. Pull-up resistors are required on the I²C/SMBus as specified in the SMBus 2.0 specification. The ZL2103 accepts most standard PMBus commands. When controlling the device with PMBus commands, it is recommended that the enable pin is tied to SGND.

I²C/SMBus Device Address Selection

When communicating with multiple devices using the I²C/SMBus interface, each device must have its own unique address so the host can distinguish between the devices. The device address can be set according to the pin-strap options listed in Table 14. Address values are right-justified.

TABLE 14. SMBus DEVICE ADDRESS SELECTION

SA PIN SETTING	SMBus ADDRESS
LOW	0x20
OPEN	0x21
HIGH	0x22

If additional device addresses are required, a resistor can be connected to the SA pin according to Table 15 to provide up to 30 unique device addresses.

Digital-DC Bus

The Digital-DC Communications (DDC) bus is used to communicate between Zilker Labs Digital-DC devices. This dedicated bus provides the communication channel between devices for features such as sequencing and fault spreading. The DDC pin on all Digital-DC devices in an application should be connected together. A pull-up resistor is required on the DDC bus in order to guarantee the rise time as expressed in Equation 13:

$$Rise\ time = R_{PU} \cdot C_{LOAD} \approx 1\mu s \quad (EQ. 13)$$

Where R_{PU} is the DDC bus pull-up resistance and C_{LOAD} is the bus loading. The pull-up resistor may be tied to VRA or to an external 3.3V or 5V supply as long as this voltage is present prior to or during device power-up. As rules of thumb, each device connected to the DDC bus presents approximately 10pF of capacitive loading, and each inch of FR4 PCB trace introduces approximately 2pF. The ideal design will use a central pull-up resistor that is well matched to the total load capacitance. In power module applications, the user should consider whether to place the pull-up resistor on the module or on the PCB of the end application.

The minimum pull-up resistance should be limited to a value that enables any device to assert the bus to a voltage that will ensure a logic 0 (typically 0.8V at the device monitoring point) given the pull-up voltage (5V if tied to VRA) and the pull-down current capability of the ZL2103 (nominally 4mA).

TABLE 15. SMBus ADDRESS VALUES

R _{SA} (kΩ)	SMBus Address
10	0x20
11	0x21
12.1	0x22
13.3	0x23
14.7	0x24
16.2	0x25
17.8	0x26
19.6	0x27
21.5	0x28
23.7	0x29
26.1	0x2A
28.7	0x2B
31.6	0x2C
34.8	0x2D
38.3	0x2E
42.2	0x2F
46.4	0x30
51.1	0x31
56.2	0x32
61.9	0x33
68.1	0x34
75	0x35
82.5	0x36
90.9	0x37
100	0x38
110	0x39
121	0x3A
133	0x3B
147	0x3C
162	0x3D

Phase Spreading

When multiple point of load converters share a common DC input supply, it is desirable to adjust the clock phase offset of each device such that not all devices start to switch simultaneously. Setting each converter to start its switching cycle at a different point in time can dramatically reduce input capacitance requirements and efficiency losses. Since the peak current drawn from the input supply is effectively spread out over a period of time, the peak current drawn at any given moment is reduced and the power losses proportional to the I_{RMS}^2 are reduced dramatically.

In order to enable phase spreading, all converters must be synchronized to the same switching clock. The CFG pin is used to set the configuration of the SYNC pin for each device as described in “Switching Frequency and PLL” on page 16.

Selecting the phase offset for the device is accomplished by selecting a device address according to the following equation:

$$\text{Phase offset} = \text{device address} \times 45^\circ$$

For example:

- A device address of 0x00 or 0x20 would configure no phase offset
- A device address of 0x01 or 0x21 would configure 45° of phase offset
- A device address of 0x02 or 0x22 would configure 90° of phase offset

The phase offset of each device may also be set to any value between 0° and 360° in 22.5° increments via the I²C/SMBus interface. Refer to Application Note [AN2033](#) for further details.

Output Sequencing

A group of Zilker Labs devices may be configured to power up in a predetermined sequence. This feature is especially useful when powering advanced processors, FPGAs, and ASICs that require one supply to reach its operating voltage prior to another supply reaching its operating voltage in order to avoid latch-up from occurring. Multi-device sequencing can be achieved by configuring each device through the I²C/SMBus interface or by using Zilker Labs patented autonomous sequencing mode.

Autonomous sequencing mode configures sequencing by using events transmitted between devices over the DDC bus.

The sequencing order is determined using each device’s SMBus address. Using autonomous sequencing mode (configured using the CFG pin), the devices must be assigned sequential SMBus addresses with no missing addresses in the chain. This mode will also constrain each device to have a phase offset according to its SMBus address as described in section “Phase Spreading” on page 25.

TABLE 16. CFG PIN CONFIGURATIONS FOR SEQUENCING AND TRACKING

R _{CFG}	SYNC PIN CONFIGURATION	SEQUENCING CONFIGURATION
Low	Input	Sequencing and Tracking are disabled.
Open	Auto detect	
High	Output	
10kΩ	Input	Sequencing and Tracking are disabled.
11kΩ	Auto detect	
12.1kΩ	Output	
14.7kΩ	Input	Device is FIRST in nested sequence. Tracking disabled.
16.2kΩ	Auto detect	
17.8kΩ	Output	
21.5kΩ	Input	Device is LAST in nested sequence. Tracking disabled.
23.7kΩ	Auto detect	
26.1kΩ	Output	
31.6kΩ	Input	Device is MIDDLE in nested sequence. Tracking disabled.
34.8kΩ	Auto detect	
38.3kΩ	Output	
46.4kΩ	Input	Sequence disabled. Tracking enabled as defined in Table 13.
51.1kΩ	Auto detect	
56.2kΩ	Output	

The sequencing group will turn on in order starting with the device with the lowest SMBus address and will continue through to turn on each device in the address chain until all devices connected have been turned on. When turning off, the device with the highest SMBus address will turn off first followed in reverse order by the other devices in the group.

Sequencing is configured by connecting a resistor from the CFG pin to ground as described in Table 16. The CFG pin is also used to set the configuration of the SYNC pin as well as to determine the sequencing method and order. Please refer to section “Switching Frequency and PLL” on page 16 for more details on the operating parameters of the SYNC pin.

Multiple device sequencing may also be achieved by issuing PMBus commands to assign the preceding device in the sequencing chain as well as the device that will follow in the sequencing chain. This method places fewer restrictions on the SMBus address (no need of sequential address) and also allows the user to assign any phase offset to any device irrespective of its SMBus device address.

The Enable pins of all devices in a sequencing group must be tied together and driven high to initiate a sequenced turn-on of the group. Enable must be driven low to initiate a sequenced turnoff of the group. Please refer to Application Note [AN2033](#) for details on sequencing via the I²C/SMBus interface.

Fault Spreading

Digital-DC devices can be configured to broadcast a fault event over the DDC bus to the other devices in the group. When a non-destructive fault occurs and the device is configured to shut down on a fault, the device will shut down and broadcast the fault event over the DDC bus. The other devices on the DDC bus will shut down together if configured to do so, and will attempt to re-start in their prescribed order if configured to do so.

Monitoring via I²C/SMBus

A system controller can monitor a wide variety of different ZL2103 system parameters through the I²C/SMBus interface. The device can monitor for fault conditions by monitoring the SALRT pin, which will be pulled low when any number of pre-configured fault conditions occur.

The device can also be monitored continuously for any number of power conversion parameters including input voltage, output voltage, output current, internal junction temperature, switching frequency and duty cycle.

The PMBus host should respond to SALRT as follows:

1. ZL device pulls SALRT low.
2. PMBus host detects that SALRT is now low, performs transmission with Alert Response Address to find which ZL device is pulling SALRT low.
3. PMBus host talks to the ZL device that has pulled SALRT low. The actions that the host performs are up to the system designer.

If multiple devices are faulting, SALRT will still be low after doing the above steps and will require transmission with the Alert Response Address repeatedly until all faults are cleared. Please refer to Application Note [AN2033](#) for details on how to monitor specific parameters via the I²C/SMBus interface.

Snapshot™ Parametric Capture

The ZL2103 offers a special feature that enables the user to capture parametric data during normal operation or following a fault. The Snapshot functionality is enabled by setting bit 1 of MISC_CONFIG to 1.

See [AN2033](#) for details on using Snapshot in addition to the parameters supported. The Snapshot feature enables the user to read the parameters via a block read transfer through the SMBus. This can be done during normal operation, although it should be noted that reading the 22 bytes will occupy the SMBus for some time.

The SNAPSHOT_CONTROL command enables the user to store the snapshot parameters to Flash memory in response to a pending fault as well as to read the stored data from Flash memory after a fault has occurred. Table 17 describes the usage of this command. Automatic writes to Flash memory following a fault are triggered when any fault threshold level is exceeded, provided that the specific fault's response is to shut down (writing to Flash memory is not allowed if the device is configured to re-try following the specific fault condition).

It should also be noted that the device's V_{DD} voltage must be maintained during the time when the device is writing the data to Flash memory; a process that requires between 700µs to

1400µs depending on whether the data is set up for a block write. Undesirable results may be observed if the device's V_{DD} supply drops below 3.0V during this process.

TABLE 17. SNAPSHOT_CONTROL COMMAND

DATA VALUE	DESCRIPTION
1	Copies current SNAPSHOT values from Flash memory to RAM for immediate access using SNAPSHOT command.
2	Writes current SNAPSHOT values to Flash memory. Only available when device is disabled.

In the event that the device experiences a fault and power is lost, the user can extract the last SNAPSHOT parameters stored during the fault by writing a 1 to SNAPSHOT_CONTROL (transfers data from Flash memory to RAM) and then issuing a SNAPSHOT command (reads data from RAM via SMBus).

Non-Volatile Memory and Device Security Features

The ZL2103 has internal non-volatile memory where user configurations are stored. Integrated security measures ensure that the user can only restore the device to a level that has been made available to them. Refer to "Start-up Procedure" on page 14 for details on how the device loads stored values from internal memory during start-up.

During the initialization process, the ZL2103 checks for stored values contained in its internal memory. The ZL2103 offers two internal memory storage units that are accessible by the user as follows:

1. **Default Store:** A power supply module manufacturer may want to protect the module from damage by preventing the user from being able to modify certain values that are related to the physical construction of the module. In this case, the module manufacturer would use the Default Store and would allow the user to restore the device to its default setting but would restrict the user from restoring the device to the factory settings.
2. **User Store:** The manufacturer of a piece of equipment may want to provide the ability to modify certain power supply settings while still protecting the equipment from modifying values that can lead to a system level fault. The equipment manufacturer would use the User Store to achieve this goal.

Please refer to Application Note [AN2033](#) for details on how to set specific security measures via the I²C/SMBus interface.

ZL2103

Revision History

The revision history provided is for informational purposes only and is believed to be accurate, but not warranted. Please go to web to make sure you have the latest Rev.

DATE	REVISION	CHANGE
4/6/2011	FN6966.5	<p>-Updated order info on page 4 as follows: Ld finish note updated matching intrepid. Replaced parts ZL2103ALAN with ZL2103ALAF. Replaced Pkg DWG# L36.6x6A with L36.6x6C</p> <p>-Abs Max Ratings on page 6, changed following from: High-Side Sup Voltage for BST Pin. . -0.3V to 30V to High-Side Sup Voltage for BST Pin. . -0.3V to 25V</p> <p>-Updated over-temp note in MIN MAX columns of spec table on page 8 from "Parameters with MIN and/or MAX limits are 100% tested at +25°C, unless otherwise specified. Temperature limits established by characterization & are not production tested." to "Compliance to datasheet limits is assured by one or more methods: production test, characterization and/or design." -Removed "Limits established by characterization & are not production tested" note</p> <p>-Replaced on page 28 POD L36.6x6A with L36.6x6C matching ordering info.</p>
12/8/2010	FN6966.4	Added following statement to disclaimer on page 27: "This product is subject to a license from Power One, Inc. related to digital power technology as set forth in U.S. Patent No. 7,000,125 and other related patents owned by Power One, Inc. These license rights do not extend to stand-alone POL regulators unless a royalty is paid to Power One, Inc."
6/24/2010	FN6966.3	Corrected a typo in Table 15 on page 24. In the first column, swapped 34.8 and 31.6 so that 31.6 is for address 0x2C and 34.8 is for address 0x2D.
2/11/2010	FN6966.2	Added "LatchupTested to JESD78" to "Absolute Maximum Ratings" on page 6.
01/22/2010	FN6966.1	Changed order information parts from "ZL2103ALAF, ZL2103ALAFT, ZL2103ALAFTK" TO "ZL2103ALAN, ZL2103ALANT, ZL2103ALANTK"
12/15/2009	FN6966.0	Initial release.

Products

Intersil Corporation is a leader in the design and manufacture of high-performance analog semiconductors. The Company's products address some of the industry's fastest growing markets, such as, flat panel displays, cell phones, handheld products, and notebooks. Intersil's product families address power management and analog signal processing functions. Go to www.intersil.com/products for a complete list of Intersil product families.

*For a complete listing of Applications, Related Documentation and Related Parts, please see the respective device information page on intersil.com: [ZL2103](http://www.intersil.com/products/ZL2103)

To report errors or suggestions for this datasheet, please go to www.intersil.com/askourstaff

FITs are available from our website at <http://rel.intersil.com/reports/search.php>

For additional products, see www.intersil.com/product_tree

Intersil products are manufactured, assembled and tested utilizing ISO9000 quality systems as noted in the quality certifications found at www.intersil.com/design/quality

Intersil products are sold by description only. Intersil Corporation reserves the right to make changes in circuit design, software and/or specifications at any time without notice. Accordingly, the reader is cautioned to verify that data sheets are current before placing orders. Information furnished by Intersil is believed to be accurate and reliable. However, no responsibility is assumed by Intersil or its subsidiaries for its use; nor for any infringements of patents or other rights of third parties which may result from its use. No license is granted by implication or otherwise under any patent or patent rights of Intersil or its subsidiaries.

This product is subject to a license from Power One, Inc. related to digital power technology as set forth in U.S. Patent No. 7,000,125 and other related patents owned by Power One, Inc. These license rights do not extend to stand-alone POL regulators unless a royalty is paid to Power One, Inc.

For information regarding Intersil Corporation and its products, see www.intersil.com

Package Outline Drawing

L36.6x6C

36 LEAD QUAD FLAT NO-LEAD PLASTIC PACKAGE

Rev 0, 4/10

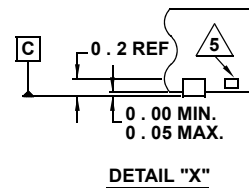
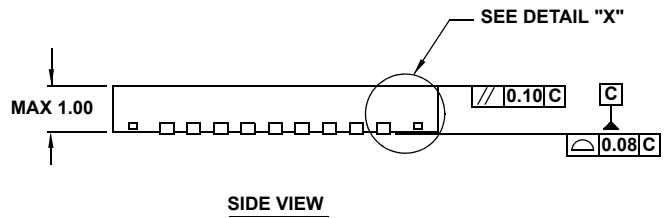
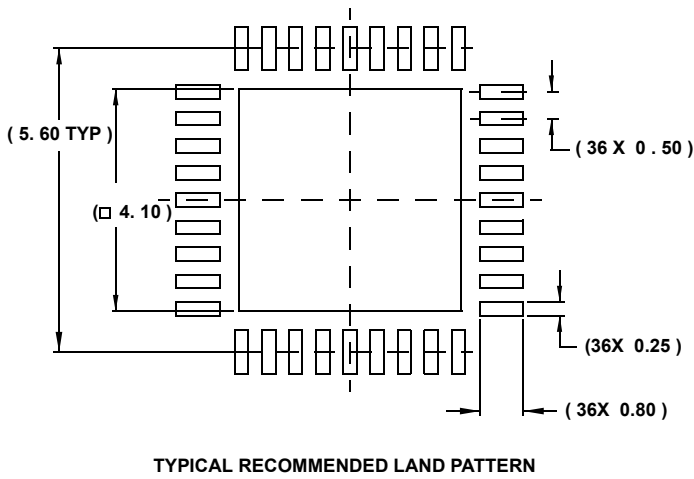
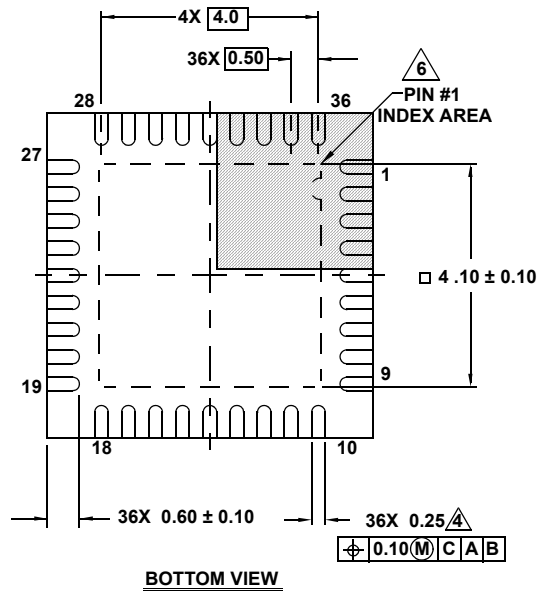
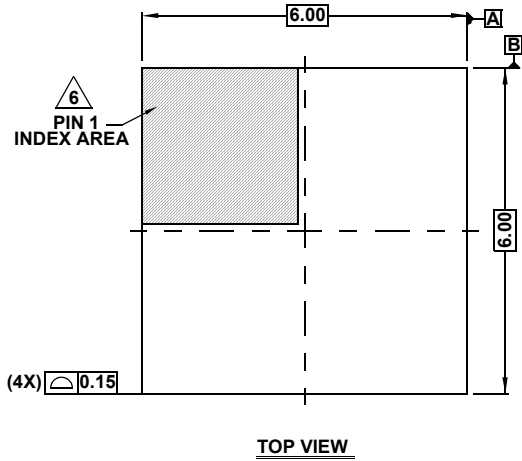

NOTES:

1. Dimensions are in millimeters.
Dimensions in () for Reference Only.
2. Dimensioning and tolerancing conform to ASME Y14.5m-1994.
3. Unless otherwise specified, tolerance : Decimal ± 0.05
4. Dimension applies to the metallized terminal and is measured between 0.15mm and 0.30mm from the terminal tip.
5. Tiebar shown (if present) is a non-functional feature.
6. The configuration of the pin #1 identifier is optional, but must be located within the zone indicated. The pin #1 identifier may be either a mold or mark feature.
7. JEDEC reference drawing: MO-220VJJD.