

3A Integrated Digital DC-DC Converter

Description

The ZL2105 is an innovative power conversion and management IC that combines an integrated synchronous step-down DC-DC converter with key power management functions in a small package, resulting in a flexible and integrated solution. Zilker Labs Digital-DC™ technology enables unparalleled power management integration while delivering industry-leading performance in a tiny footprint.

The ZL2105 can provide an output voltage from 0.6 V to 5.5 V from an input voltage between 4.5 V and 14 V. Internal 4.5 A low $R_{DS(ON)}$ synchronous power MOSFETs enable the ZL2105 to deliver continuous loads up to 3 A with high efficiency, and an internal Schottky bootstrap diode further reduces discrete component count. The ZL2105 also supports phase spreading for reduced system capacitance.

Power management features such as digital soft-start delay and ramp, sequencing, tracking, and margining can be configured by simple pin-strapping or through an on-chip serial port. The ZL2105 uses standard PMBus™ protocol for communicating with other devices to provide intelligent system power management.

Features

Power Conversion

- High efficiency
- 3 A continuous output current
- Integrated MOSFET switches
- 4.5 V to 14 V input range
- 0.54 V to 5.5 V output range (with margin)
- ±1% output voltage accuracy
- 200 kHz to 2 MHz switching frequency
- Supports phase spreading
- Small footprint (6 x 6 mm QFN package)

Power Management

- Digital soft start/stop
- Precision delay and ramp-up
- Power good/enable
- Voltage tracking, sequencing, and margining
- Output voltage/current monitoring
- Thermal monitor w/ shutdown
- Non-volatile memory
- I²C/SMBus™ communication bus
- PMBus compatible

Applications

- Telecom and storage equipment
- Digital set-top box
- Industrial supplies
- 12 V distributed power systems
- Point of load converters

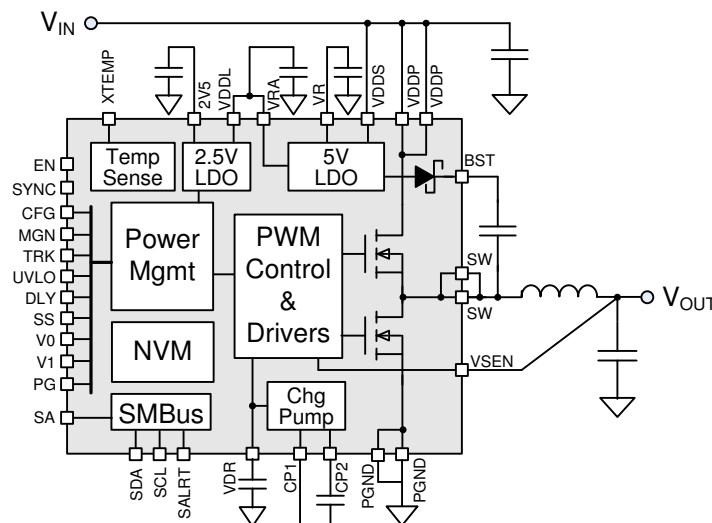

Figure 1. Block Diagram

Table of Contents

1. Electrical Characteristics	3
2. Pin Descriptions	6
3. Typical Application Circuit	8
4. ZL2105 Overview	10
4.1 Digital-DC Architecture	10
4.2 Power Conversion Overview	11
4.3 Power Management Overview	12
4.4 Multi-mode Pins	12
5. Power Conversion Functional Description	13
5.1 Internal Bias Regulators and Input Supply Connections	13
5.2 High-side Driver Boost Circuit	13
5.3 Low-side Driver Supply Options	13
5.4 Dual Input Supply Configuration	14
5.5 Output voltage Selection	15
5.6 Start-up Procedure	15
5.7 Soft Start Delay and Ramp Times	16
5.8 Switching Frequency and PLL	17
5.9 Component Selection	19
5.10 Current Sensing and Current Limit Threshold Selection	22
5.11 Loop Compensation	22
5.12 Non-linear Response (NLR) Settings	23
5.13 Efficiency Optimized Drive Dead-time Control	24
6. Power Management Functional Description	24
6.1 Input Undervoltage Lockout	24
6.2 Power Good (PG) and Output Overvoltage Protection	25
6.3 Output Overvoltage Protection	25
6.4 Output Pre-Bias Protection	25
6.5 Output Overcurrent Protection	26
6.6 Thermal Overload Protection	26
6.7 Voltage Tracking	27
6.8 Voltage Margining	28
6.9 I ² C/SMBus Communications	29
6.10 I ² C/SMBus Device Address Selection	29
6.11 Phase Spreading	29
6.12 Output Sequencing	30
6.13 Monitoring via I ² C/SMBus	31
6.14 Temperature Monitoring using the XTEMP Pin	31
6.15 Non-Volatile Memory and Device Security Features	32
7. Package Dimensions	33
8. Ordering Information	34
9. Related Documentation	34
10. Revision History	35

1. Electrical Characteristics

Table 1. Absolute Maximum Ratings

Voltage measured with respect to SGND. Operating beyond these limits may cause permanent damage to the device. Functional operation beyond the Recommended Operating Conditions is not implied.

Parameter	Pin	Comments	Value	Unit
DC Supply Voltage	VDDP, VDDS, VDR		-0.3 to 17	V
Logic Supply Voltage	VDDL	Optional	-0.3 to 6.5	V
High Side Supply Voltage	BST		-0.3 to 25	V
High Side Boost Voltage	BST - SW		-0.3 to 8	V
Switch Node Current	SW	Sink or Source	4.5	A
Internal Drive References	VR, VRA		-0.3 to 6.5	V
Internal 2.5 V Reference	V25		-0.3 to 3	V
Logic I/O Voltage	EN, MGN, PG, SDA, SCL, SA, SALRT, SS, DLY, SYNC, VTRK, UVLO, V(0,1), ILIM, VSEN, CFG		-0.3 to 6.5	V
Ground Differential	DGND - SGND PGND - SGND		±0.3	V
MOSFET Drive Reference Current	VR		30	mA
Analog Reference Current	VRA		150	mA
2.5 V Reference Current	V25		60	mA
Junction Temperature	–		-55 to 150	°C
Storage Temperature	–		-55 to 150	°C
Lead Temperature	All	Soldering, 10 s	300	°C

Table 2. Recommended Operating Conditions and Thermal Information

Parameter	Symbol	Min	Typ	Max	Unit
Input Supply Voltage Range, VDDP, VDDS (See Figure 8)	VDDS tied to VR, VRA	4.5	–	5.5	V
	VR, VRA floating	5	–	14	V
Logic Supply Voltage Range, VDDL	VDDL (optional)	3.0	–	5.5	V
Internal Driver Supply, VDR	VDR	10	–	14	V
Output Voltage Range ¹	V _{OUT}	0.54	–	5.5	V
Operating Junction Temperature Range	T _J	-40	–	125	°C
Junction to Ambient Thermal Impedance ²	Θ _{JA}	–	35	–	°C/W
Junction to Case Thermal Impedance ³	Θ _{JC}	–	5	–	°C/W

Notes:

- Includes margin
- Θ_{JA} is measured in free air with the device mounted on a multi-layer FR4 test board and the exposed metal pad soldered to a low impedance ground plane using multiple vias.
- For Θ_{JC}, the “case” temperature is measured at the center of the exposed metal pad. See Figure 4 for thermal derating.

Table 3. Electrical Specifications

$V_{DDP} = V_{DDS} = 12\text{ V}$, $T_A = -40^\circ\text{C}$ to 85°C unless otherwise noted. Typical values are at $T_A = 25^\circ\text{C}$.

Parameter	Conditions	Min (Note 3)	Typ	Max (Note 3)	Unit
Input and Supply Characteristics					
I _{DDS} supply current	f _{SW} = 200 kHz, no load	–	2	3	mA
	f _{SW} = 1 MHz, no load	–	5	6	mA
I _{DDL} supply current	f _{SW} = 200 kHz, no load	–	8	16	mA
	f _{SW} = 1 MHz, no load	–	10	20	mA
I _{DDS} shutdown current	EN = 0 V, VDDL tied to VRA, No I ² C/SMBus activity	–	0.7	2	mA
I _{DDL} shutdown current	EN = 0 V, VDDL = 5 V, No I ² C/SMBus activity	–	225	500	μA
VR reference output voltage	V _{DD} > 5.5 V, I _{VR} < 5 mA	4.5	5.2	5.5	V
VRA reference output voltage	V _{DD} > 5.5 V, I _{VRA} < 35 mA	4.5	5.2	5.5	V
V25 reference output voltage	I _{V25} < 50 mA	2.25	2.5	2.75	V
Output Characteristics					
Output Current		–	–	3	A
Output voltage adjustment range ¹	V _{IN} > V _{OUT}	0.6	–	5.0	V
Output voltage setpoint resolution	Set using resistors	–	10	–	mV
	Set using I ² C/SMBus	–	±0.025	–	% FS
VSEN output voltage accuracy	Includes line, load, temp	-1	–	1	%
VSEN input bias current	VSEN = 5.5 V	–	100	200	μA
Soft start delay duration range ²	Set using DLY pin or resistor	7	–	200	ms
	Set using I ² C/SMBus	0.007	–	500	s
Soft start delay duration accuracy		–	6	–	ms
Soft start ramp duration range	Set using SS pin	10	–	100	ms
	Set using resistor or via I ² C	0	–	200	ms
Soft start ramp duration accuracy		–	100	–	μs
Logic Input/Output Characteristics					
Logic input current	EN, SCL, SDA pins	-250		250	nA
Logic input low, V _{IL}		–	–	0.8	V
Logic input OPEN (N/C)	Multi-mode logic pins	–	1.4	–	V
Logic input high, V _{IH}		2.0	–	–	V
Logic output low, V _{OL}	I _{OL} ≤ 4 mA	–	–	0.4	V
Logic output high, V _{OH}	I _{OH} ≥ -2 mA	2.25	–	–	V
Tracking					
VTRK input bias current	VTRK = 5.5 V	–	110	200	μA
VTRK tracking accuracy	100% Tracking, V _{OUT} - VTRK	- 100	–	+ 100	mV

Notes:

- Does not include margin
- The device requires approximately 6 ms following an enable signal and prior to output ramp. The minimum settable delay is 7 ms.
- Compliance to datasheet limits is assured by one or more methods: production test, characterization and/or design.

Table 3 is continued on the following page

Table 3. Electrical Characteristics (continued)

$V_{DDP} = V_{DDS} = 12\text{ V}$, $T_A = -40^\circ\text{C}$ to 85°C unless otherwise noted. Typical values are at $T_A = 25^\circ\text{C}$.

Parameter	Conditions	Min (Note 3)	Typ	Max (Note 3)	Unit
Oscillator and Switching Characteristics					
Switch node current, I_{SW}	Sourcing or Sinking	–	3	4.0	A
Switching frequency range		200	–	2000	kHz
Switching frequency set-point accuracy	Predefined settings	-5	–	5	%
Minimum SYNC pulse width		150	–	–	ns
Input clock frequency drift tolerance	External clock source	-13	–	13	%
Maximum duty cycle		90	–	–	%
$R_{DS(ON)}$ of High Side N-channel FETs	$I_{SW} = 1\text{ A}$, $V_{GS} = 4.7\text{ V}$	–	125	180	m Ω
$R_{DS(ON)}$ of Low Side N-channel FETs	$I_{SW}=1\text{A}$, $V_{GS}=8.5\text{V}$, Charge Pump	–	123	140	m Ω
	$I_{SW}=1\text{A}$, $V_{GS}=12\text{V}$	–	114	130	m Ω
Fault Protection Characteristics					
UVLO threshold range		3.79	–	13.2	V
UVLO setpoint accuracy		-2	–	2	%
UVLO hysteresis	Factory default	–	3	–	%
	Configurable via I ² C/SMBus	0	–	100	%
UVLO delay		–	–	2.5	μs
Power good low threshold	Factory default	–	90	–	% V_{OUT}
Power good high threshold	Factory default	–	115	–	% V_{OUT}
Power good hysteresis	Factory default	–	5	–	%
Power good delay	Using pin-strap or resistor ¹	0	–	200	ms
	Configurable via I ² C/SMBus	0	–	500	s
VSEN undervoltage threshold	Factory default	–	85	–	% V_{OUT}
	Configurable via I ² C/SMBus	0	–	110	% V_{OUT}
VSEN overvoltage threshold	Factory default	–	115	–	% V_{OUT}
	Configurable via I ² C/SMBus	0	–	115	% V_{OUT}
VSEN undervoltage hysteresis		–	5	–	% V_O
VSEN undervoltage/ overvoltage fault response time	Factory default	–	16	–	μs
	Configurable via I ² C/SMBus	5	–	60	μs
Peak current limit threshold		0.2	–	4.5	A
Current limit setpoint accuracy	Using ILIM pin or via I ² C/SMBus	–	± 100	–	mA
Current limit shutdown delay	Factory default	–	5	–	t_{SW}^2
	Configurable via I ² C/SMBus	1	–	32	t_{SW}^2
Thermal protection threshold (junction temperature)	Factory default	–	125	–	$^\circ\text{C}$
	Configurable via I ² C/SMBus	-40	–	125	$^\circ\text{C}$
Thermal protection hysteresis		–	15	–	$^\circ\text{C}$

Notes:

1. Factory default Power Good delay is set to the same value as the soft start ramp time.
2. $t_{SW} = 1/f_{SW}$, where f_{SW} is the switching frequency.
3. Compliance to datasheet limits is assured by one or more methods: production test, characterization and/or design.

2. Pin Descriptions

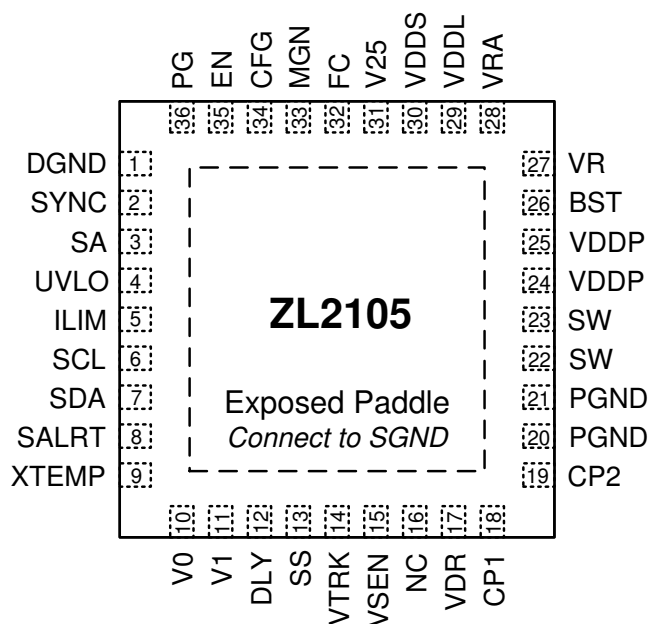

Figure 2. ZL2105 Pin Configurations (top view)

Table 4. Pin Descriptions

Pin	Label	Type ¹	Description
1	DGND	PWR	Digital ground. Common return for digital signals. Connect to low impedance ground plane.
2	SYNC	I/O, M	Clock synchronization input. Used to set switching frequency of internal clock or for synchronization to external frequency reference. Programmable open drain output. Factory default is push-pull
3	SA	I,M	Serial address pin used to assign unique SMBus address to each IC.
4	UVLO	I,M	Sets the input undervoltage lockout threshold that disables the device.
5	ILIM	I,M	Sets the current limit threshold level.
6	SCL	I/O	Serial clock signal for system communications.
7	SDA	I/O	Serial data signal for system communications.
8	SALRT	O	SMBus alert signal.
9	XTEMP	I	External temperature sensor input.
10,11	V0, V1	I,M	Output voltage select pins. Used to set the output voltage.
12	DLY	I,M	Soft start delay select pin. Sets the delay from when EN is asserted until the output voltage starts to ramp.
13	SS	I,M	Digital soft-start/stop. Sets the ramp period for the output to reach the desired regulation point (after soft-start delay period, if applicable).
14	VTRK	I	Track input. Allows the output to track another voltage.
15	VSEN	I	Output voltage positive feedback sensing node.
16	NC	-	No internal connection.
17	VDR	PWR	Supply pin for internal drivers.
18, 19	CP1,CP2	I/O	Level-shift charge pump for 5 V operation. Connect external capacitor.

Notes:

1. I = Input, O = Output, PWR = Power or Ground. M = Multi-mode pins.

Table 4. Pin Descriptions (continued)

Pin	Label	Type ¹	Description
20,21	PGND	PWR	Power ground. Common return for internal switching MOSFETs.
22,23	SW	I/O	Switching node (level-shift common).
24,25	VDDP	PWR	Bias power for internal switching MOSFETs (return is PGND).
26	BST	PWR	Bootstrap V_{DD} for level-shift driver (referenced to SW).
27	VR	PWR	Regulated bias from internal 5V low-dropout regulator (return is PGND). Decouple with a 4.7 μ F capacitor to PGND. Connect 91 Ω resistor between VR and VRA.
28	VRA	PWR	Regulated 5 V bias for internal analog circuitry (return is SGND). Decouple with a 4.7 μ F capacitor to SGND. Connect 91 Ω resistor between VR and VRA.
29	VDDL	PWR	Internal logic supply. Connect to VRA or apply a 3.0-5.5 V external supply. Return is SGND.
30	VDDS	PWR	IC supply voltage (return is SGND).
31	V25	PWR	Regulated bias from internal 2.5 V low-dropout regulator. Decouple with a 10 μ F capacitor.
32	FC	I	Frequency compensation select pin. Used to set loop compensation.
33	MGN	I	Signal that enables margining of output voltage.
34	CFG	I	Configuration pin. Sets switching phase delay and sequencing order.
35	EN	I	Enable input. Active high signal enables the device.
36	PG	O	Power good output. This pin transitions high 100 ms after output voltage stabilizes within regulation band. Programmable open drain output. Factory default is open drain.
ePad	SGND	PWR	Exposed thermal pad. Common return for analog signals; internal connection to SGND. Connect to low impedance ground plane.

Notes:

1. I = Input, O = Output, PWR = Power or Ground. M = Multi-mode pins. Please refer to Section 4.4 “Multi-mode Pins,” on page 12.

3. Typical Application Circuit

The following application circuit represents a typical implementation of the ZL2105.

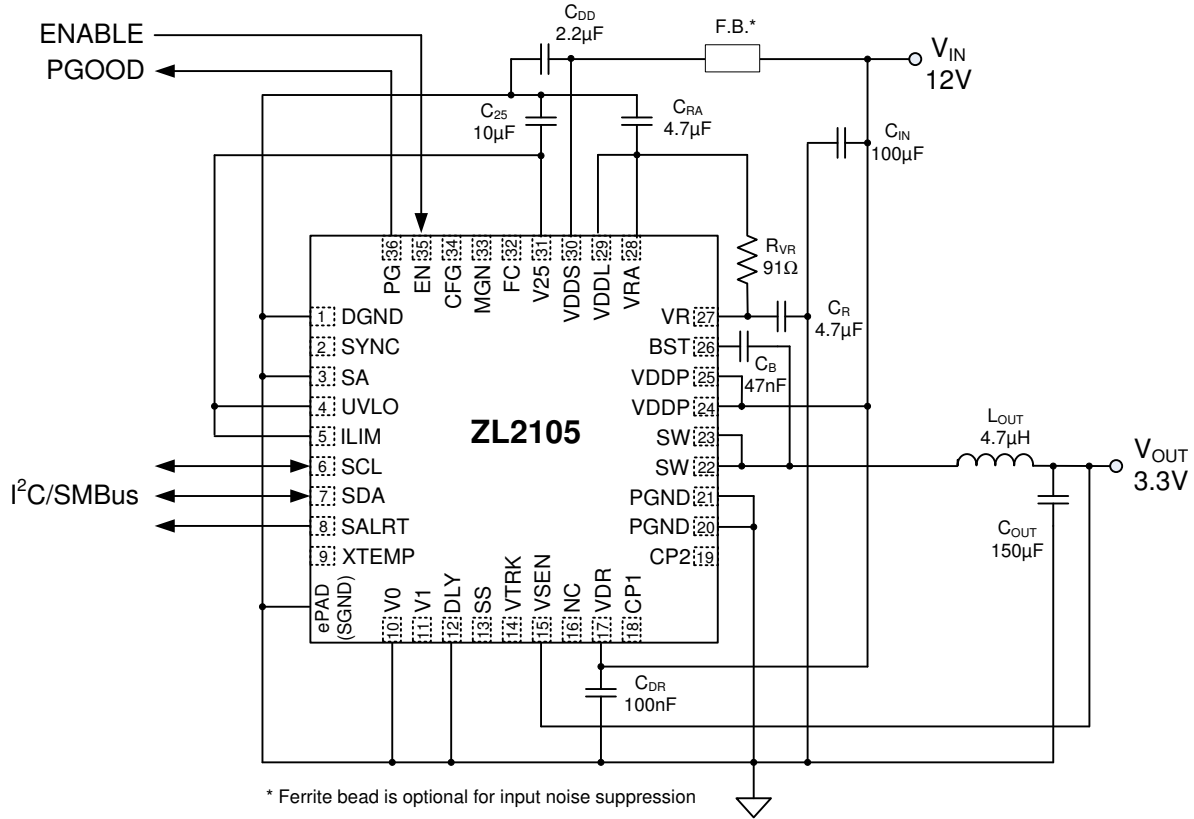

Figure 3. 12 V to 3.3 V / 3 A Application Circuit
 (10.8 V UVLO, 10 ms SS delay, 50 ms SS ramp, 12 V used for low-side FET driver)

For all applications, the ZL2105 must be derated according to the Safe Operating Area (SOA) curves.

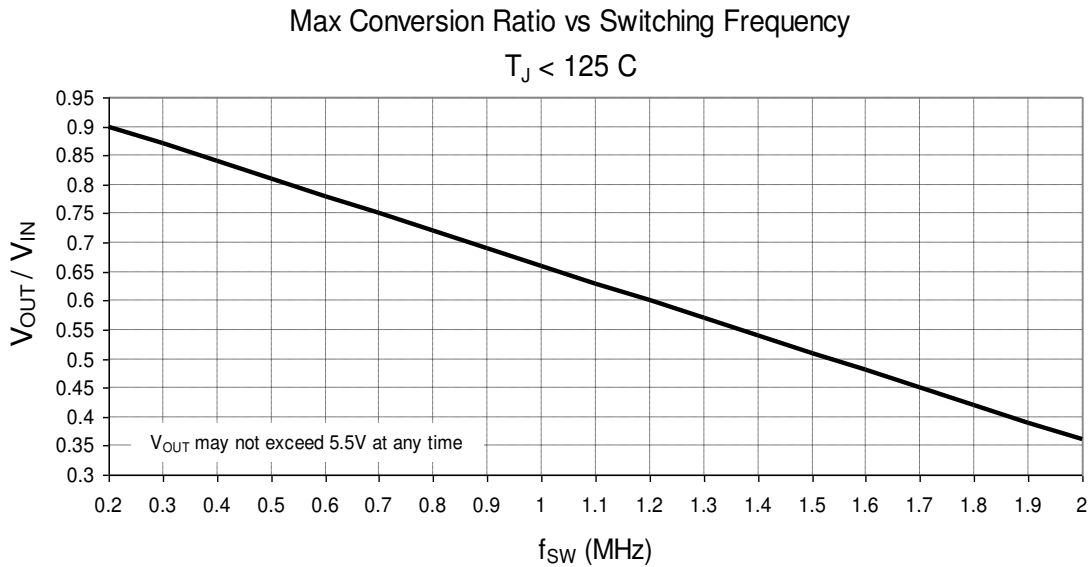
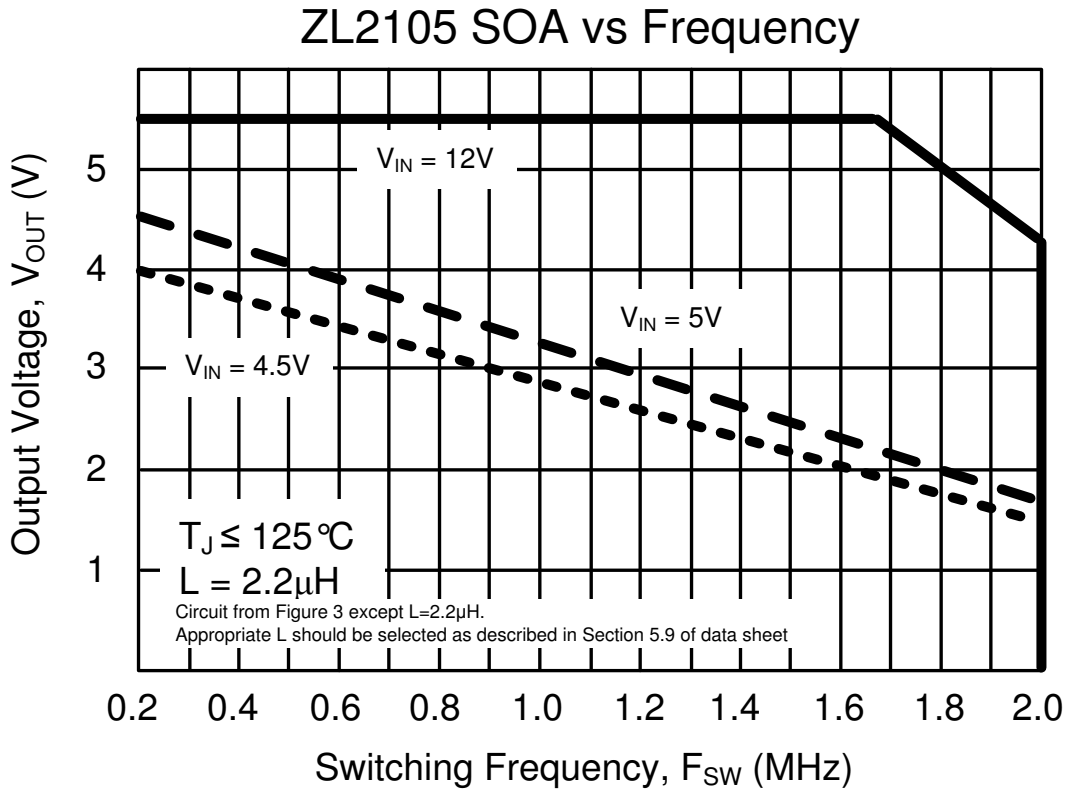

Figure 4. ZL2105 SOA Curves

4. ZL2105 Overview

4.1 Digital-DC Architecture

The ZL2105 is an innovative mixed-signal power conversion and power management IC based on Zilker Labs patented Digital-DC technology that provides an integrated, high performance step-down converter for point of load applications. The ZL2105 integrates all necessary PWM control circuitry as well as synchronous 4.5 A N-channel MOSFETs in order to provide an extremely small solution for providing load currents up to 3 A. Its unique PWM loop utilizes an ideal mix of analog and digital blocks to enable precise control of the entire power conversion process with no software required, resulting in a very flexible device that is also very easy to use. An extensive set of power management functions are fully integrated and can be configured using simple pin connections. The user configuration can be saved in an internal non-volatile memory (NVM). Additionally, all functions can be configured and monitored via the SMBus hardware interface using standard PMBus commands, allowing ultimate flexibility.

Once enabled, the ZL2105 is immediately ready to regulate power and perform power management tasks with no programming required. Advanced configuration options and real-time configuration changes are available via the I²C/SMBus interface if desired and continuous monitoring of multiple operating parameters is possible with minimal interaction from a host controller. Integrated sub-regulation circuitry enables single supply operation from any supply between 4.5 V and 14 V with no secondary bias supplies needed. The ZL2105

can also be configured to operate from a 3.3 V or 5 V standby supply when the main power rail is not present, allowing the user to configure and/or read diagnostic information from the device when the main power has been interrupted or is disabled.

The ZL2105 can be configured by simply connecting its pins according to the tables provided in the following sections. Additionally, a comprehensive set of tools and application notes are available to help simplify the design process. An evaluation board is also available to help the user become familiar with the device. This board can be evaluated as a standalone platform using pin configuration settings. A Windows™-based GUI is also provided to enable full configuration and monitoring capability via the I²C/SMBus interface using an available computer and the included USB cable.

Application notes and reference designs are available to assist the user in designing to specific application demands. Please register for My ZL on www.intersil.com/zilkerlabs/ to access the most up-to-date documentation or call your local Zilker Labs sales office to order an evaluation kit.

4.2 Power Conversion Overview

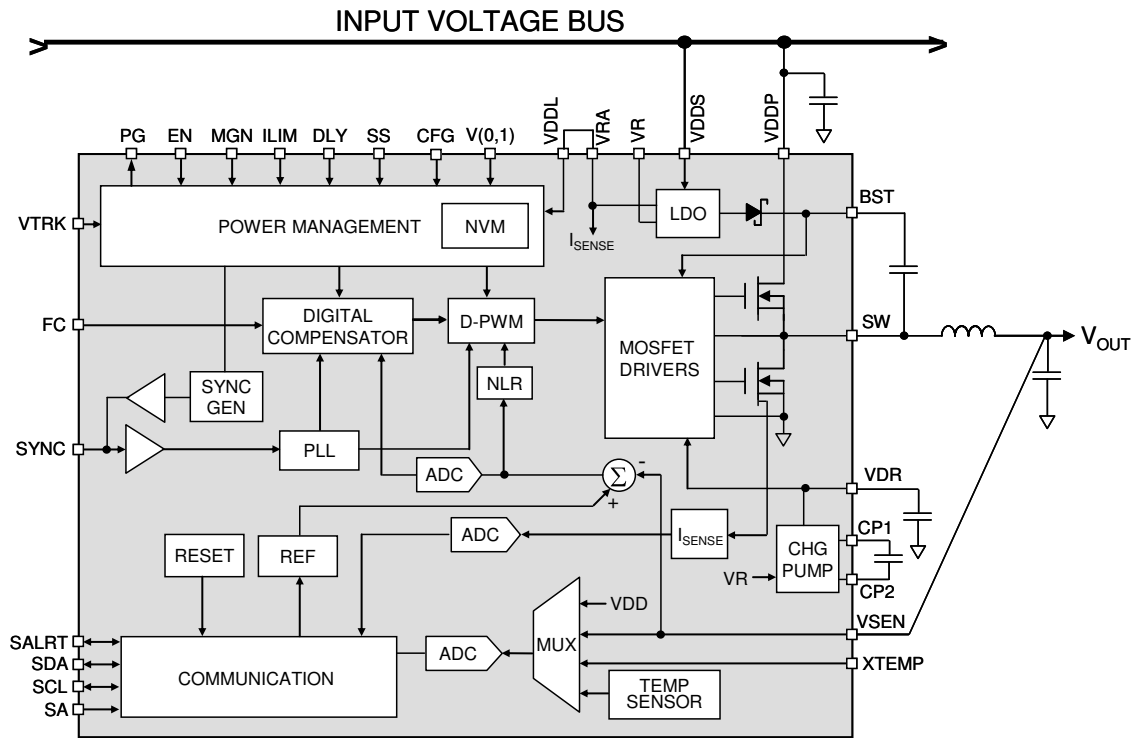

Figure 5. ZL2105 Block Diagram

The ZL2105 operates as a voltage-mode, synchronous buck converter with a selectable constant frequency PWM control scheme. The ZL2105 incorporates dual low $R_{DS(ON)}$ synchronous MOSFETs to help minimize the required circuit footprint.

is known as the duty cycle D , which is described by the following equation:

$$D = \frac{V_{OUT}}{V_{IN}}$$

During time D , QH is on and $V_{IN} - V_{OUT}$ is applied across the inductor.

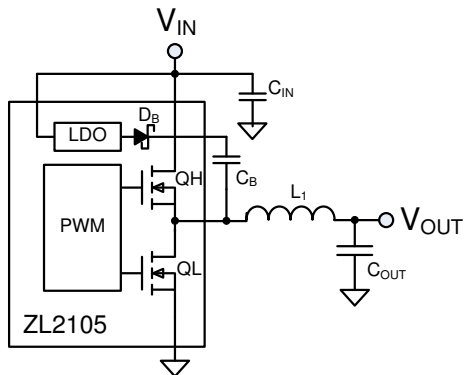

Figure 6. Synchronous Buck Converter

Figure 6 illustrates the basic synchronous buck converter topology showing the primary power train components. This converter is also called a step-down converter, as the output voltage must always be lower than the input voltage. The ZL2105 integrates two MOSFETs; QH is the top control MOSFET and QL is the bottom synchronous MOSFET. The amount of time that QH is on as a fraction of the total switching period

As shown in Figure 5, the output voltage is directly applied to the VSEN pin. The VSEN signal is then compared to an internal programmable reference voltage that is set to the desired output voltage level. The error signal derived from this comparison is converted to a digital value with a fast analog to digital (A/D) converter. The digital signal is also applied to an adjustable digital compensation filter, and the compensated signal is used to derive the appropriate PWM duty cycle for driving the internal MOSFETs. The ZL2105 also incorporates a non-linear response (NLR) loop to improve the response time and reduce the output deviation as a result of a load transient. The ZL2105 monitors the power converter’s operating conditions and continuously adjusts the turn-on and turn-off timing of the high-side and low-side MOSFETs to optimize the overall efficiency of the power supply.

4.3 Power Management Overview

The ZL2105 incorporates a wide range of configurable power management features that are simple to implement with no external components. Additionally, the ZL2105 includes circuit protection features that continuously safeguard the device and load from damage due to unexpected system faults. The ZL2105 can continuously monitor input voltage, output voltage/current, internal temperature, and the temperature of an external thermal diode. A Power Good output signal is also included to enable power-on reset functionality for an external processor.

All power management functions can be configured using either pin configuration techniques (see Figure 7) or via the I²C/SMBus interface. Monitoring parameters can also be pre-configured to provide alerts for specific conditions. See Application Note AN2013 for more details on SMBus monitoring.

4.4 Multi-mode Pins

Most power management features can be configured using the multi-mode pins. The multi-mode pins can respond to four different connections as shown in Table 5. These pins are sampled when power is applied or by issuing a PMBus Restore command (See Application Note AN2013).

Pin-strap Settings: Using this method, each pin can take on one of three possible states: LOW, OPEN, or HIGH. These pins can be connected to the VR or V25 pins for logic HIGH settings, as either pin provides a regulated voltage higher than 2 V. Using a single pin one of three settings can be selected, and using two pins the user can select one of nine settings.

Table 5. Multi-mode Pin Configuration

Pin Tied To	Value
LOW (Logic LOW)	< 0.8 VDC
OPEN (N/C)	No connection
HIGH (Logic HIGH)	> 2.0 VDC
Resistor to SGND	Set by resistor value

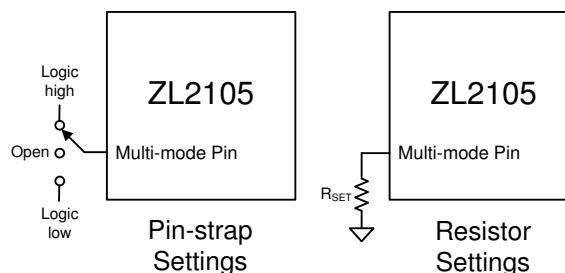

Figure 7. Pin-strap and Resistor Setting Examples

Resistor Settings: This method allows a greater range of adjustability when connecting a finite value resistor (in a specified range) between the multi-mode pin and SGND. Standard 1% resistor values are used, and only every fourth E96 resistor value is used so the device can reliably recognize the value of resistance connected to the pin while eliminating the error associated with the resistor accuracy. A total of 25 unique selections are available using a single resistor.

I²C/SMBus Method: Almost any ZL2105 function can be configured via the I²C/SMBus interface using standard PMBus commands. Additionally, any value that has been configured using the pin-strap or resistor setting methods can also be re-configured and/or verified via the I²C/SMBus. See Application Note AN2013 for more details.

The SMBus device address and VOUT_MAX are the only parameters that must be set by external pins. All other device parameters can be set via the I²C/SMBus. The device address is set using the SA pin. VOUT_MAX is determined as 10% greater than the voltage set by the V0 and V1 pins.

5. Power Conversion Functional Description

5.1 Internal Bias Regulators and Input Supply Connections

The ZL2105 employs three internal low dropout (LDO) regulators to supply bias voltages for internal circuitry as follows:

VR: The VR LDO provides a regulated 5 V bias supply for the MOSFET driver circuits. It is powered from the VDDS pin. A 4.7 μF filter capacitor is required at the VR pin.

VRA: The VRA LDO provides a regulated 5 V bias supply for the current sense circuit and other analog circuitry. It is powered from the VDDS pin. A small filter capacitor is required at the VRA pin. For single supply operation, this pin should be connected to the VDDL pin so the VRA LDO can be used to power the digital core logic circuitry.

V25: The V25 LDO provides a regulated 2.5 V bias supply for the main controller circuitry. It is powered from the VDDL pin. A 10 μF filter capacitor is required at the V25 pin.

When the input supply (VDDS) is higher than 5.5 V, the VR and VRA pins should not be connected to any other pins. They should have a filter capacitor and a 91 Ω resistor attached as shown in Figure 8. Due to the dropout voltage associated with the VR and VRA bias regulators, the VDDS pin must be connected to the VR and VRA pins for designs operating from a supply below 5.5 V. Figure 8 illustrates the required connections for both cases.

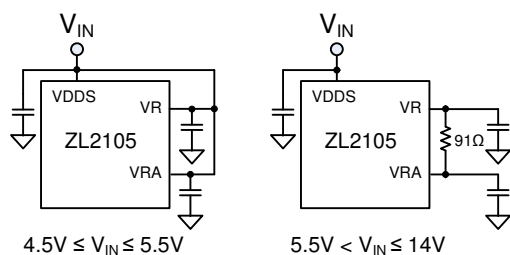

Figure 8. Input Supply Connections

Note: the internal bias regulators, VR and VRA, are not designed to be outputs for powering other circuitry. Do not attach external loads to either of these pins. The multi-mode pins may be connected to the V25 pin for logic HIGH settings.

5.2 High-side Driver Boost Circuit

The gate drive voltage for the high-side MOSFET driver is generated by a floating bootstrap capacitor, C_B (see Figure 6). When the lower MOSFET (QL) is turned on, the SW node is pulled to ground and the capacitor is charged from the internal VR bias regulator through diode D_B . When QL turns off and the upper MOSFET (QH) turns on, the SW node is pulled up to V_{DDP} and the voltage on the bootstrap capacitor is boosted approximately 5V above V_{DDP} to provide the necessary voltage to power the high-side driver. An internal Schottky diode is used with C_B to help maximize the high-side drive supply voltage.

5.3 Low-side Driver Supply Options

The ZL2105 provides multiple options for powering the internal low-side MOSFET drivers as follows:

12 V Supply: When operating from a 12 V input supply (or any supply 9 V or higher), efficiency can be optimized by operating the low-side MOSFET driver directly from the input supply. Connecting the input supply to the VDR pin (with no external capacitor connected between CP1 and CP2) applies the input supply directly to the low-side driver. This is the simplest method of powering the low-side driver and requires the fewest components. Figure 9 illustrates the required connections for implementing this configuration.

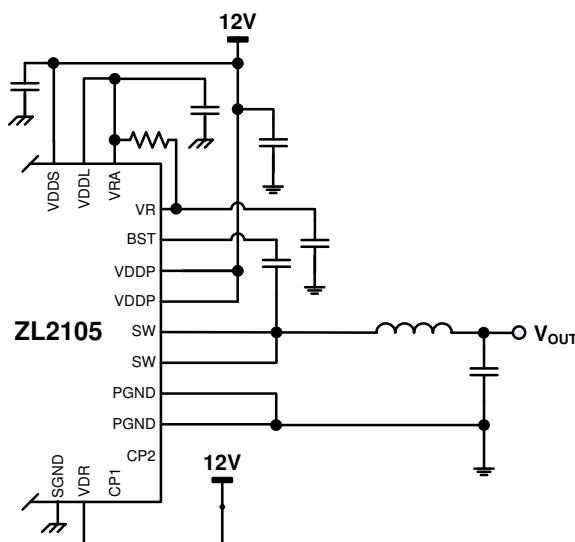

Figure 9. Using an External 12 V Supply to Power the Low-side Driver

Internal Charge Pump: A voltage doubler circuit can be used to optimize efficiency when operating from an input supply that is below 9 V or may occasionally drop below 9 V. The internal charge pump is enabled by connecting a 10 nF capacitor between the CP1 and CP2 pins and a 100 nF capacitor between VDR and PGND. The charge pump provides a low-side driver supply based on the equation below:

$$V_{CP} = (VR - 0.5V) \times 2$$

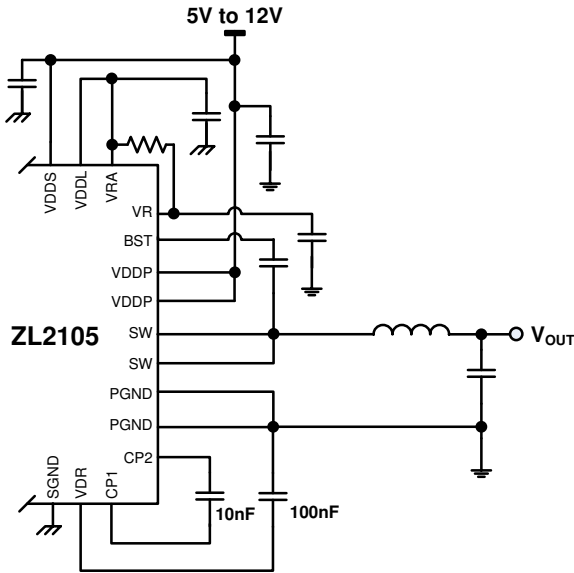

Figure 10. Using the Internal Charge Pump to Power the Low-side Driver

The required connections are shown in Figure 10.

Note: when the input supply is always lower than 5.5 V, the VDDDS pin must be connected to the VR pin as shown in Figure 11. The resistor between VR and VRA is not required when VDDL and VDDDS are tied directly to VR and VRA since this configuration overrides the internal LDOs.

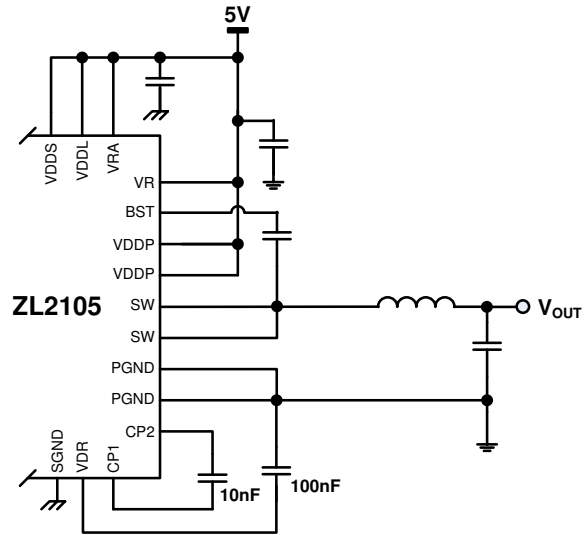

Figure 11. Powering the Low-side Driver When VDDDS ≤ 5.5 V

5.4 Dual Input Supply Configuration

The ZL2105 allows the use of two unique input supplies to enable communication with the device when the primary power rail is not present. Typical applications of this scenario use a 12 V supply as the main power input and either a 3.3 V or 5 V standby supply to power the device during periods when the primary power supply is disabled or not operational. This configuration allows a host controller to communicate with the ZL2105 when the 12 V main supply is not available. Figure 12 shows the typical connections required for this configuration. This figure uses the 12 V supply for powering the low-side driver.

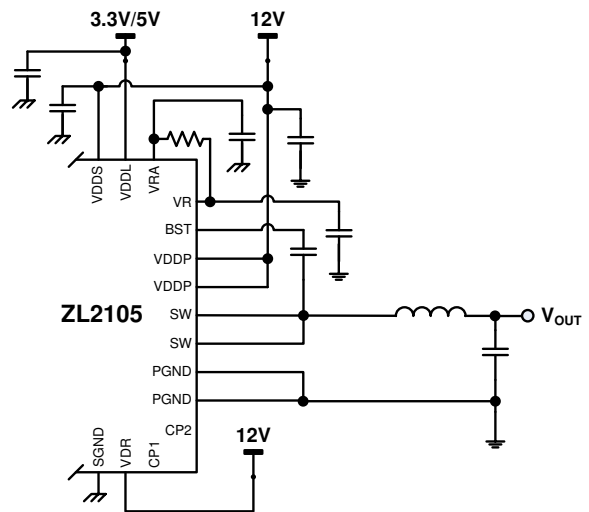

Figure 12. Dual Input Supply Operation

5.5 Output voltage Selection

The output voltage may be set to any voltage between 0.6 V and 5.0 V provided that the input voltage is higher than the desired output voltage by an amount sufficient to prevent the device from exceeding its maximum duty cycle specification. Using the pin-strap method, V_{OUT} can be set to any of nine standard voltages as shown in Table 6.

Table 6. Pin-strap Output Voltage Settings

		V0		
		LOW	OPEN	HIGH
V1	LOW	0.6 V	0.8 V	1.0 V
	OPEN	1.2 V	1.5 V	1.8 V
	HIGH	2.5 V	3.3 V	5.0 V

The resistor setting method can be used to set the output voltage to levels not available in Table 6. Resistors R0 and R1 are selected to produce a specific voltage between 0.6 V and 5.0 V in 10 mV steps. Resistor R1 provides a coarse setting and resistor R0 provides a fine adjustment, thus eliminating the additional errors associated with using two 1% resistors (this typically adds 1.4% error).

To set V_{OUT} using resistors, follow the steps below to calculate an index value and then use Table 7 to select the resistor that corresponds to the calculated index value as follows:

1. Calculate Index1:

$$\text{Index1} = 4 \times V_{OUT} \quad (V_{OUT} \text{ in } 10 \text{ mV steps})$$
2. Round the result down to the nearest whole number.
3. Select the value of R1 from Table 7 using the Index1 rounded value from step 2.
4. Calculate Index0:

$$\text{Index0} = 100 \times V_{OUT} - (25 \times \text{Index1})$$
5. Select the value of R0 from Table 7 using the Index0 value from step 4.

Table 7. Resistors for Setting Output Voltage

Index	R0 or R1	Index	R0 or R1
0	10 kΩ	13	34.8 kΩ
1	11 kΩ	14	38.3 kΩ
2	12.1 kΩ	15	42.2 kΩ
3	13.3 kΩ	16	46.4 kΩ
4	14.7 kΩ	17	51.1 kΩ
5	16.2 kΩ	18	56.2 kΩ
6	17.8 kΩ	19	61.9 kΩ
7	19.6 kΩ	20	68.1 kΩ
8	21.5 kΩ	21	75 kΩ
9	23.7 kΩ	22	82.5 kΩ
10	26.1 kΩ	23	90.9 kΩ
11	28.7 kΩ	24	100 kΩ
12	31.6 kΩ		

Example: For $V_{OUT} = 1.33 \text{ V}$,

$$\text{Index1} = 4 \times 1.33 \text{ V} = 5.32;$$

From Table 7, R1 = 16.2 kΩ

$$\text{Index0} = (100 \times 1.33 \text{ V}) - (25 \times 5) = 8;$$

From Table 7, R0 = 21.5 kΩ

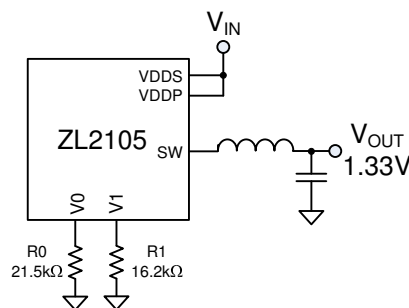

Figure 13. Output Voltage Resistor Setting Example

The output voltage may also be set to any value between 0.6 V and 5.5 V using the I²C interface. See Application Note AN2013 for details.

5.6 Start-up Procedure

The ZL2105 follows a specific internal start-up procedure after power is applied to the VDD pins (VDDL, VDDP, and VDDS). Table 8 describes the start-up sequence.

If the device is to be synchronized to an external clock source, the clock frequency must be stable prior to asserting the EN pin. The device requires approximately 10-20 ms to check for specific values stored in its internal memory. If the user has stored values in memory, those values will be loaded. The device will then check the status of all multi-mode pins and load the values associated with the pin settings.

Once this process is completed, the device is ready to accept commands via the I²C/SMBus interface and the device is ready to be enabled. Once enabled, the device requires approximately 7 ms before its output voltage may be allowed to start its ramp-up process. If a soft-start delay period less than 7 ms has been configured (using PMBus commands), the device will default to a 7 ms delay period. If a delay period greater than 7 ms is configured, the device will wait for the configured delay period prior to starting to ramp its output.

After the delay period has expired, the output will begin to ramp towards its target voltage according to the pre-configured soft-start ramp time that has been set using the SS pin.

5.7

Soft Start Delay and Ramp Times

In some applications, it may be necessary to set a delay from when an enable signal is received until the output voltage starts to ramp to its target value. In addition, the designer may wish to precisely set the time required for V_{OUT} to ramp to its target value after the delay period has expired. These features may be used as part of an overall inrush current management strategy or to precisely control how fast a load IC is turned on. The ZL2105 gives the system designer several options for precisely and independently controlling both the delay and ramp time periods.

The soft-start delay period begins when the EN pin is asserted and ends when the delay time expires. The soft-start delay period is set using the DLY pin.

The soft-start ramp timer enables a precisely controlled ramp to the nominal V_{OUT} value that begins once the delay period has expired. The ramp-up is guaranteed monotonic and its slope may be precisely set using the SS pin.

The soft-start delay and ramp times can be set to one of three standard values according to Table 9 and Table 10 respectively.

Table 9. Soft Start Delay Settings

DLY Pin Setting	Soft Start Delay Time
LOW	10 ms
OPEN	50 ms
HIGH	100 ms

Table 8. ZL2105 Start-up Sequence

Step #	Step Name	Description	Time Duration
1	Power Applied	Input voltage is applied to the ZL2105's VDD pins (VDDL, VDDP, VDDS)	Depends on input supply ramp time
2	Internal Memory Check	The device will check for values stored in its internal memory. This step is also performed after a Restore command.	Approx 10-20 ms (device will ignore an enable signal or PMBus traffic during this period)
3	Multi-mode Pin Check	The device loads values configured by the multi-mode pins.	
4	Device Ready	The device is ready to accept an enable signal.	—
5	Pre-ramp Delay	The device requires approximately 6 ms following an enable signal and prior to ramping its output. Additional pre-ramp delay may be configured using the DLY pin.	Approximately 6 ms

Table 10. Soft Start Ramp Settings

SS Pin Setting	Soft Start Ramp Time
LOW	10 ms
OPEN	50 ms
HIGH	100 ms

If the desired soft start delay and ramp times are not one of the values listed in Table 9 and Table 10, the times can be set to a custom value by connecting a resistor from the DLY or SS pin to SGND using the appropriate resistor values from Table 11. The value of this resistor is measured upon start-up or Restore and will not change if the resistor is varied after power has been applied to the ZL2105. See Figure 14 for typical connections using resistors.

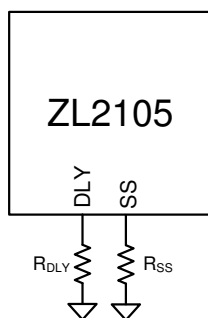

Figure 14. DLY and SS Pin Resistor Connections

Table 11. DLY and SS Resistor Values

DLY or SS	R _{DLY} or R _{SS}	DLY or SS	R _{DLY} or R _{SS}
0 ms	10 kΩ	110 ms	28.7 kΩ
10 ms	11 kΩ	120 ms	31.6 kΩ
20 ms	12.1 kΩ	130 ms	34.8 kΩ
30 ms	13.3 kΩ	140 ms	38.3 kΩ
40 ms	14.7 kΩ	150 ms	42.2 kΩ
50 ms	16.2 kΩ	160 ms	46.4 kΩ
60 ms	17.8 kΩ	170 ms	51.1 kΩ
70 ms	19.6 kΩ	180 ms	56.2 kΩ
80 ms	21.5 kΩ	190 ms	61.9 kΩ
90 ms	23.7 kΩ	200 ms	68.1 kΩ
100 ms	26.1 kΩ		

The soft start delay and ramp times can also be set to custom values via the I²C/SMBus interface. When the SS delay time is set to 0 ms, the device will begin its ramp-up after the internal circuitry has initialized (approx. 6 ms). When the soft-start ramp period is set to 0 ms, the output will ramp up as quickly as the output load capacitance will allow.

5.8 Switching Frequency and PLL

The ZL2105 incorporates an internal phase-locked loop (PLL) to clock the internal circuitry. The PLL can be driven by an external clock source connected to the SYNC pin. When using the internal oscillator, the SYNC pin can be configured as a clock source for other Zilker Labs devices.

The CFG pin is used to select the operating mode of the SYNC pin, configure sequencing, and enable tracking. Table 12 describes the operating modes for the SYNC pin. Section 6.12 “Output Sequencing,” on Page 30 describes sequencing and tracking. Figure 15 illustrates the typical connections for each SYNC configuration.

Table 12. SYNC Pin Function Selection

CFG Pin	SYNC Pin Function
LOW	SYNC is configured as an input
OPEN	Auto detect mode
HIGH	SYNC is configured as an output f _{sw} = 400 kHz

Configuration A: SYNC OUTPUT

When the SYNC pin is configured as an output (CFG pin is tied HIGH), the device will run from its internal oscillator and will drive the resulting internal oscillator signal (preset to 400 kHz) onto the SYNC pin so other devices can be synchronized to it. The SYNC pin will not be checked for an incoming clock signal while in this mode.

Configuration B: SYNC INPUT

When the SYNC pin is configured as an input (CFG pin is tied LOW), the device will automatically check for a clock signal on the SYNC pin each time the EN pin is asserted. The ZL2105’s oscillator will then synchronize both frequency and phase with the rising edge of the external clock signal. The incoming clock signal must be in the range of 200 kHz to 2 MHz with a minimum duty cycle, and must be stable when the EN pin is asserted. See Table 3 for a complete list of performance requirements for the incoming clock signal.

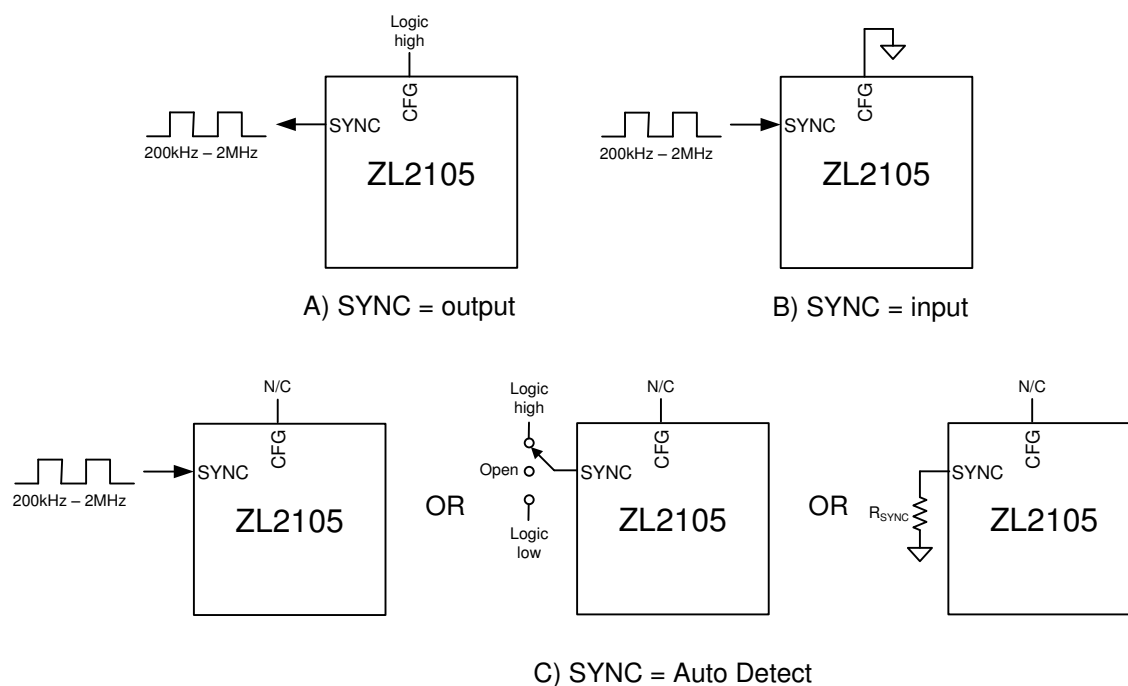

Figure 15. SYNC Pin Configurations.

Configuration C: SYNC AUTO DETECT

When the SYNC pin is configured in auto detect mode (CFG pin is left OPEN), the device will automatically check for a clock signal on the SYNC pin after enable is asserted.

- If a valid clock signal is present, the ZL2105's oscillator will then synchronize both frequency and phase with the rising edge of the external clock signal. The incoming clock signal must be in the range of 200 kHz to 2 MHz with a minimum duty cycle, and must be stable when the EN pin is asserted. See Table 3 for a complete list of performance requirements for the incoming clock signal.

- If no incoming clock signal is present, the ZL2105 will configure the switching frequency according to the state of the SYNC pin as listed in Table 13. In this configuration, the SYNC pin is sampled only on start-up and will not modify its switching frequency if the SYNC pin is re-configured after start-up (unless the power is recycled).

Table 13. Switching Frequency Selection

SYNC Pin	Frequency
LOW	200 kHz
OPEN	400 kHz
HIGH	1 MHz
Resistor	See Table 14

If the user wishes to run the ZL2105 at a frequency not listed in Table 13, the switching frequency can be set using an external resistor, R_{SYNC} , connected between SYNC and SGND using Table 14.

Table 14. R_{SYNC} Resistor Values

F _{SW}	R _{SYNC}	F _{SW}	R _{SYN}
200 kHz	10 kΩ	571 kHz	28.7 kΩ
222 kHz	11 kΩ	615 kHz	31.6 kΩ
242 kHz	12.1 kΩ	667 kHz	34.8 kΩ
267 kHz	13.3 kΩ	727 kHz	38.3 kΩ
296 kHz	14.7 kΩ	889 kHz	46.4 kΩ
320 kHz	16.2 kΩ	1000 kHz	51.1 kΩ
364 kHz	17.8 kΩ	1143 kHz	56.2 kΩ
400 kHz	19.6 kΩ	1333 kHz	68.1 kΩ
421 kHz	21.5 kΩ	1600 kHz	82.5 kΩ
471 kHz	23.7 kΩ	2000 kHz	100 kΩ
533 kHz	26.1 kΩ		

The switching frequency can also be set to any value between 200 kHz and 2 MHz using the I²C/SMBus interface. The available frequencies are bounded by $f_{SW} = 8 \text{ MHz}/N$, where $4 \leq N \leq 40$. See Application Note AN2013 for details.

If multiple Zilker Labs devices are used together, connecting the SYNC pins together will force all devices to synchronize with each other. The CFG pin of one device must set its SYNC pin as an output and the remaining devices must have their SYNC pins set as an input.

Note: The switching frequency read back using the appropriate PMBus command will differ slightly from the selected value in Table 14. The difference is due to hardware quantization.

5.9 Component Selection

The ZL2105 is a synchronous buck converter with integrated MOSFETs that uses an external inductor and capacitors to perform the power conversion process. The proper selection of the external components is critical for optimized performance. For more detailed guidelines regarding component selection, refer to Application Note AN2011.

To select the appropriate external components for the desired performance goals, the power supply requirements listed in Table 15 must be known.

Table 15. Power Supply Requirements

Parameter	Range	Example Value
Input voltage (V _{IN})	4.5–14.0 V	12 V
Output voltage (V _{OUT})	0.6–5.5 V	1.2 V
Output current (I _{OUT})	0 to 3 A	2 A
Output voltage ripple (V _{orip})	< 3% of V _{OUT}	1% of V _{OUT}
Output load step (I _{ostep})	< I _o	50% of I _o
Output load step rate	—	10 A/μS
Output deviation due to load step	—	50 mV
Maximum PCB temp.	120°C	85°C
Desired efficiency	—	85%
Other considerations	—	Optimize for small size

5.9.1 Design Goal Trade-offs

The design of the buck power stage requires several compromises among size, efficiency, and cost. The inductor core loss increases with frequency, so there is a trade-off between a small output filter made possible by a higher switching frequency and getting better power supply efficiency. Size can be decreased by increasing the switching frequency at the expense of efficiency. Cost can be minimized by using through-hole inductors and capacitors; however these components are physically large.

To start the design, select a frequency based on Table 16. This frequency is a starting point and may be adjusted as the design progresses.

Table 16. Circuit Design Considerations

Frequency Range	Efficiency	Circuit Size
200–400 kHz	Highest	Larger
400–800 kHz	Moderate	Smaller
800 kHz – 2 MHz	Lower	Smallest

5.9.2 Inductor Selection

The output inductor selection process must include several trade-offs. A high inductance value will result in a low ripple current (I_{opp}), which will reduce output capacitance and produce a low output ripple voltage, but may also compromise output transient load performance. Therefore, a balance must be struck between output ripple and optimal load transient

performance. A good starting point is to select the output inductor ripple equal to the expected load transient step magnitude (I_{ostep}):

$$I_{opp} = I_{ostep}$$

Now the output inductance can be calculated using the following equation, where V_{INM} is the maximum input voltage:

$$L_{OUT} = \frac{V_{OUT} \times \left(1 - \frac{V_{OUT}}{V_{INM}}\right)}{f_{sw} \times I_{opp}}$$

The average inductor current is equal to the maximum output current. The peak inductor current (I_{Lpk}) is calculated using the following equation where I_{OUT} is the maximum output current:

$$I_{Lpk} = I_{OUT} + \frac{I_{opp}}{2}$$

Select an inductor rated for the average DC current with a peak current rating above the peak current computed above.

In over-current or short-circuit conditions, the inductor may have currents greater than 2X the normal maximum rated output current. It is desirable to use an inductor that still provides some inductance to protect the load and the internal MOSFETs from damaging currents in this situation.

Once an inductor is selected, the DCR and core losses in the inductor are calculated. Use the DCR specified in the inductor manufacturer's datasheet:

$$P_{LDCR} = DCR \times I_{Lrms}^2$$

I_{Lrms} is given by

$$I_{Lrms} = \sqrt{I_{OUT}^2 + \frac{I_{opp}^2}{12}}$$

where I_{OUT} is the maximum output current. Next, calculate the core loss of the selected inductor. Since this calculation is specific to each inductor and manufacturer, refer to the chosen inductor datasheet. Add the core loss and the ESR loss and compare the total loss to the maximum power dissipation recommendation in the inductor datasheet.

5.9.3 Output Capacitor Selection

Several trade-offs must also be considered when selecting an output capacitor. Low ESR values are needed to have a small output deviation during transient load steps (V_{osag}) and low output voltage ripple (V_{orip}). However, capacitors with low ESR, such as semi-stable (X5R and X7R) dielectric ceramic capacitors, also have relatively low capacitance values. Many designs can use a combination of high capacitance devices and low ESR devices.

For high ripple currents, a low capacitance value can cause a significant amount of output voltage ripple. Likewise, in high transient load steps, a relatively large amount of capacitance is needed to minimize the output voltage deviation while the inductor current ramps up or down to the new steady state output current value.

As a starting point, apportion one-half of the output ripple voltage to the capacitor ESR and the other half to capacitance, as shown in the following equations:

$$C_{OUT} = \frac{I_{opp}}{8 \times f_{sw} \times \frac{V_{orip}}{2}}$$

$$ESR = \frac{V_{orip}}{2 \times I_{opp}}$$

Use these values to make an initial capacitor selection, using a single or capacitor several capacitors in parallel.

After a capacitor has been selected, the resulting output voltage ripple can be calculated using the following equation:

$$V_{\text{orip}} = I_{\text{opp}} \times \text{ESR} + \frac{I_{\text{opp}}}{8 \times f_{\text{sw}} \times C_{\text{OUT}}}$$

Because each part of this equation was made to be less than or equal to half of the allowed output ripple voltage, the V_{orip} should be less than the desired maximum output ripple.

For more information on the performance of the power supply in response to a transient load, refer to Application Note AN2011.

5.9.4 Input Capacitor

It is highly recommended that dedicated input capacitors be used in any point-of-load design, even when the supply is powered from a heavily filtered 5 or 12 V “bulk” supply from an off-line power supply. This is because of the high RMS ripple current that is drawn by the buck converter topology. This ripple (I_{CINrms}) can be determined from the following equation:

$$I_{\text{CINrms}} = I_{\text{OUT}} \times \sqrt{D \times (1 - D)}$$

Without capacitive filtering near the power supply circuit, this current would flow through the supply bus and return planes, coupling noise into other system circuitry. The input capacitors should be rated at 1.4X the ripple current calculated above to avoid overheating of the capacitors due to the high ripple current, which can cause premature failure. Ceramic capacitors with X7R or X5R dielectric with low ESR and 1.1X the maximum expected input voltage are recommended.

5.9.5 Bootstrap Capacitor Selection

The high-side driver boost circuit utilizes an internal Schottky diode (D_B) and an external bootstrap capacitor (C_B) to supply sufficient gate drive for the high-side MOSFET driver. C_B should be a 47 nF ceramic type rated for at least 6.3V.

5.9.6 C_{V25} Selection

This capacitor is used to both stabilize and provide noise filtering for the 2.5 V internal power supply. It should be between 4.7 and 10 μF , and should use a semi-stable X5R or X7R dielectric ceramic with a low (less than 10 m Ω) ESR, and should have a rating of 4 V or more.

5.9.7 C_{VR} Selection

This capacitor is used to both stabilize and provide noise filtering for the 5 V reference supply (V_R). It should be between 4.7 and 10 μF , and be a semi-stable X5R or X7R dielectric ceramic capacitor with a low ESR less than 10 m Ω , and be rated 6.3 V or more. Because the current for the bootstrap supply is drawn from this capacitor, C_{VR} should be sized at least 10X the value of C_B so that a discharged C_B does not cause the voltage on it to droop excessively during a C_B recharge pulse.

5.9.8 C_{VRA} Selection

This capacitor is used to both stabilize and provide noise filtering for the analog 5 V reference supply (V_{RA}). It should be between 2.2 and 10 μF , be a semi-stable X5R or X7R dielectric ceramic capacitor with a low ESR less than 10 m Ω , and be rated 6.3 V or more.

5.9.9 R_{VR} Selection

A 91 Ω resistor should be placed between VR and VRA to reduce noise and help the stability of the VR and VRA regulators over all operating conditions.

5.9.10 Thermal Considerations

In typical applications, the ZL2105's high efficiency will limit the internal power dissipation inside the package. However, in applications that require a high ambient operating temperature the user must perform some thermal analysis to ensure that the ZL2105's maximum junction temperature is not violated.

The ZL2105 has a maximum junction temperature limit of 125°C, and the internal over temperature limiting circuitry will force the device to shut down if its junction temperature exceeds this threshold. In order to calculate the maximum junction temperature, the user must first calculate the power dissipated inside the IC (P_Q) as follows:

$$P_Q = (I_{\text{LOAD}})^2 [R_{\text{DS(ON)QH}}(\text{DC}) + (R_{\text{DS(ON)QL}})(1-\text{DC})]$$

The maximum operating junction temperature can then be calculated using the following equation:

$$T_{\text{jmax}} = T_{\text{PCB}} + P_Q \times \theta_{\text{JC}}$$

Where T_{PCB} is the expected maximum printed circuit board temperature, and θ_{JC} is the junction-to-case thermal resistance for the ZL2105 package.

5.10 Current Sensing and Current Limit Threshold Selection

It is recommended that the user include a current limiting mechanism in their design to protect the power supply from damage and prevent excessive current from being drawn from the input supply in the event that the output is shorted to ground or an overload condition is imposed on the output. Current limiting is accomplished by sensing the current through the circuit during a portion of the duty cycle.

The ZL2105 incorporates MOSFET sensing across the internal low-side MOSFET. The user can select one of the three current limit thresholds using the ILIM pin according to Table 17.

Table 17. Current Limit Selections

ILIM Pin	Current Limit Threshold
LOW	3.0 A
OPEN	4.0 A
HIGH	4.5 A

If the desired current limit threshold is not available in Table 17, the current limit threshold can be set in 200 mA increments using an external resistor, R_{LIM} , connected between the ILIM pin and SGND using resistor values from Table 18.

The current limit threshold can also be set to a custom value via the I²C/SMBus interface. Please refer to Application Note AN2013 for further details.

Table 18. Current Limit Threshold Settings

I_{LIM}	R_{LIM}	I_{LIM}	R_{LIM}
0.2 A	11 k Ω	2.6 A	34.8 k Ω
0.4 A	12.1 k Ω	2.8 A	38.3 k Ω
0.6 A	13.3 k Ω	3.0 A	42.2 k Ω
0.8 A	14.7 k Ω	3.2 A	46.4 k Ω
1.0 A	16.2 k Ω	3.4 A	51.1 k Ω
1.2 A	17.8 k Ω	3.6 A	56.2 k Ω
1.4 A	19.6 k Ω	3.8 A	61.9 k Ω
1.6 A	21.5 k Ω	4.0 A	68.1 k Ω
1.8 A	23.7 k Ω	4.2 A	75 k Ω
2.0 A	26.1 k Ω	4.4 A	82.5 k Ω
2.2 A	28.7 k Ω	4.6 A	90.9 k Ω
2.4 A	31.6 k Ω		

5.11 Loop Compensation

The ZL2105 operates as a voltage-mode synchronous buck controller with a fixed frequency PWM scheme. Although the ZL2105 uses a digital control loop, it operates much like a traditional analog PWM controller. Figure 16 is a simplified block diagram of the ZL2105 control loop, which differs from an analog control loop only by the constants in the PWM and compensation blocks. As in the analog controller case, the compensation block compares the output voltage to the desired voltage reference and compensation zeroes are added to keep the loop stable. The resulting integrated error signal is used to drive the PWM logic, converting the error signal to a duty cycle to drive the internal MOSFETs.

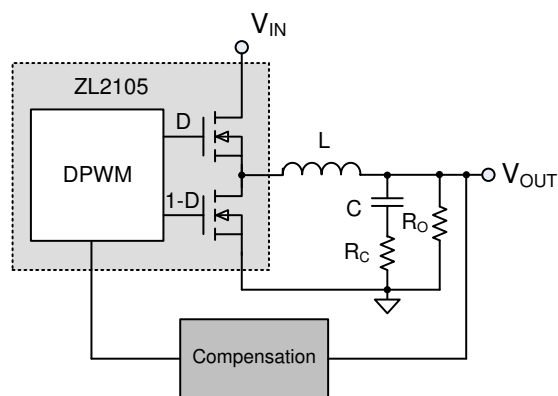

Figure 16. Control Loop Block Diagram

Table 19. Resistor Settings for Loop Compensation

NLR	f_n Range	f_{zesr} Range	R_{FC}
Off	$f_{sw}/60 < f_n < f_{sw}/30$	$f_{zesr} > f_{sw}/10$	10 k Ω
		$f_{sw}/10 > f_{zesr} > f_{sw}/30$	11 k Ω
		$f_{sw}/30 > f_{zesr} > f_{sw}/60$	12.1 k Ω
	$f_{sw}/120 < f_n < f_{sw}/60$	$f_{zesr} > f_{sw}/10$	13.3 k Ω
		$f_{sw}/10 > f_{zesr} > f_{sw}/30$	14.7 k Ω
		$f_{sw}/30 > f_{zesr} > f_{sw}/60$	16.2 k Ω
	$f_{sw}/240 < f_n < f_{sw}/120$	$f_{zesr} > f_{sw}/10$	17.8 k Ω
		$f_{sw}/10 > f_{zesr} > f_{sw}/30$	19.6 k Ω
		$f_{sw}/30 > f_{zesr} > f_{sw}/60$	21.5 k Ω
On	$f_{sw}/60 < f_n < f_{sw}/30$	$f_{zesr} > f_{sw}/10$	23.7 k Ω
		$f_{sw}/10 > f_{zesr} > f_{sw}/30$	26.1 k Ω
		$f_{sw}/30 > f_{zesr} > f_{sw}/60$	28.7 k Ω
	$f_{sw}/120 < f_n < f_{sw}/60$	$f_{zesr} > f_{sw}/10$	31.6 k Ω
		$f_{sw}/10 > f_{zesr} > f_{sw}/30$	34.8 k Ω
		$f_{sw}/30 > f_{zesr} > f_{sw}/60$	38.3 k Ω
	$f_{sw}/240 < f_n < f_{sw}/120$	$f_{zesr} > f_{sw}/10$	42.2 k Ω
		$f_{sw}/10 > f_{zesr} > f_{sw}/30$	46.4 k Ω
		$f_{sw}/30 > f_{zesr} > f_{sw}/60$	51.1 k Ω

In the ZL2105, the compensation zeros are set by configuring the FC pin or via the I²C/SMBus interface once the user has calculated the required settings. This method eliminates the inaccuracies due to the component tolerances associated with using external resistors and capacitors required with traditional analog controllers. Utilizing the loop compensation settings shown in Table 19 will yield a conservative crossover frequency at a fixed fraction of the switching frequency ($f_s/20$) and 60° of phase margin.

Step 1: Using the following equation, calculate the resonant frequency of the LC filter, f_n .

$$f_n = \frac{1}{2\pi\sqrt{L \times C}}$$

Step 2: Calculate the ESR zero frequency (f_{zesr}).

$$f_{zesr} = \frac{1}{2\pi CRc}$$

Step 3: Based on Table 19, determine the appropriate resistor, R_{FC} .

The FC pin can be pin-strapped as LOW, OPEN, or HIGH. These three positions are the same as the first three entries in Table 19.

The loop compensation coefficients can also be set via the I²C/SMBus interface. Please refer to Application Note AN2013 for further details. Refer to Application Note AN2016 for further technical details on setting loop compensation.

5.12 Non-linear Response (NLR) Settings

The ZL2105 incorporates a non-linear response (NLR) loop that decreases the response time and the output voltage deviation in the event of a sudden output load current step. The NLR loop incorporates a secondary error signal processing path that bypasses the primary error loop when the output begins to transition outside of the standard regulation limits. This scheme results in a higher equivalent loop bandwidth than what is possible using a traditional linear loop.

When a load current step function imposed on the output causes the output voltage to drop below the lower regulation limit, the NLR circuitry will force a positive correction signal that will turn on the upper MOSFET and quickly force the output to increase. Conversely, a negative load step (i.e. removing a large load current) will cause the NLR circuitry to force a negative correction signal that will turn on the lower MOSFET and quickly force the output to decrease.

The NLR loop is enabled through the FC pin by selecting the appropriate resistor value for the loop compensation settings in Table 19. When operating the ZL2105 with a switching frequency greater than 1333 kHz, NLR must be disabled.

5.13 Efficiency Optimized Drive Dead-time Control

The ZL2105 utilizes a closed loop algorithm to optimize the dead-time applied between the gate drive signals for the top and bottom MOSFETs. In a synchronous buck topology, potentially damaging currents can flow in the circuit of both top and bottom MOSFETs are turned on simultaneously for periods of time exceeding a few nanoseconds, and system efficiency can be adversely affected if both MOSFETs are turned off for too long. Therefore, it is advantageous to minimize the dead-time to provide peak optimal efficiency without compromising system reliability.

The duty cycle of a buck converter is determined to a first-order degree by the input and output voltage ratio. However, non-idealities exist that cause the real duty cycle to extend beyond the ideal value. Dead-time is one of the non-idealities that can be manipulated to improve efficiency. The ZL2105 has an internal algorithm that can continuously adjust the dead-time to optimize duty cycle, thus maximizing efficiency.

6. Power Management Functional Description

6.1 Input Undervoltage Lockout

The input undervoltage lockout (UVLO) prevents the ZL2105 from operating when the input falls below a preset threshold, indicating the input supply is out of its specified range. The UVLO threshold (V_{UVLO}) can be set between 4.5 V and 10.2 V using the UVLO pin. The simplest implementation is to connect the UVLO pin as shown in Table 20. If the UVLO pin is left unconnected, the UVLO threshold will default to 6.5V.

Table 20. UVLO Pin Settings

Pin Setting	UVLO Threshold
LOW	4.5 V
OPEN	6.5 V
HIGH	10.2 V

If the desired UVLO threshold is not on of the listed choices, the user can configure a threshold between 3.79 V and 13.2 V by connecting a resistor between the UVLO pin and GND by selecting the appropriate resistor from Table 21.

V_{UVLO} can also be set to any value between 3.79 V and 13.2 V via the I²C/SMBus interface.

Table 21. UVLO Resistor Values

UVLO	R _{UVLO}	UVLO	R _{UVLO}
3.79 V	23.7 kΩ	7.42 V	46.4 kΩ
4.18 V	26.1 kΩ	8.18 V	51.1 kΩ
4.59 V	28.7 kΩ	8.99 V	56.2 kΩ
5.06 V	31.6 kΩ	9.90 V	61.9 kΩ
5.57 V	34.8 kΩ	10.90 V	68.1 kΩ
6.13 V	38.3 kΩ	12.00 V	75 kΩ
6.75 V	42.2 kΩ	13.20 V	82.5 kΩ

Once an input undervoltage fault condition occurs, the device can respond in a number of ways as follows:

1. Continue operating without interruption
2. Continue operating for a given delay period, followed by shutdown if the fault still exists. The device will remain in shutdown until instructed to restart.
3. Initiate an immediate shutdown until the fault has been cleared. The user can select a specific number of retry attempts.

6.2 Power Good (PG) and Output Overvoltage Protection

The ZL2105 provides a Power Good (PG) signal that indicates the output voltage is within a specified tolerance of its target level and no fault condition exists. By default, the PG pin will assert if the output is within +15%/-10% of the target voltage. These limits may be changed via the I²C/SMBus interface.

A PG delay period is defined as the time from when all conditions for asserting PG are met and when the PG pin is actually asserted. This feature is commonly used instead of an external reset controller to signal the power supply is at its target voltage prior to enabling any powered circuitry. By default, the ZL2105 PG delay is set equal to the soft-start ramp time setting. Thus if the soft-start ramp time is set to 10ms, the PG pin will assert 10ms after the output is within its specified tolerance band. The PG delay period can be set independent of the soft-start ramp time via the I²C/SMBus interface.

6.3 Output Overvoltage Protection

The ZL2105 offers an internal output overvoltage protection circuit that can be used to protect sensitive load circuitry from being subjected to a voltage higher than its prescribed limits. A hardware comparator is used to compare the actual output voltage (seen at the VSEN pin) to a threshold set to 15% higher than the target output voltage (the default setting). If the VSEN voltage exceeds this threshold, the PG pin will de-assert and the device can then respond in a number of ways as follows:

1. Initiate an immediate shutdown until the fault has been cleared. The user can select a specific number of retry attempts.
2. Turn off the high-side MOSFET and turn on the low-side MOSFET. The low-side MOSFET remains on until the device attempts a restart.

The default response from an overvoltage fault is to immediately shut down. The device will continuously check for the presence of the fault condition, and when the fault condition no longer exists the device will be re-enabled.

For continuous overvoltage protection when operating from an external clock, the only allowed response is an immediate shutdown.

Please refer to Application Note AN2013 for details on how to select specific overvoltage fault response options via I²C/SMBus.

6.4 Output Pre-Bias Protection

An output pre-bias condition exists when an externally applied voltage is present on a power supply's output before the power supply's control IC is enabled. Certain applications require that the converter not be allowed to sink current during start up if a pre-bias condition exists at the output. The ZL2105 provides pre-bias protection by sampling the output voltage prior to initiating an output ramp.

If a pre-bias voltage lower than the target voltage exists after the pre-configured delay period has expired, the target voltage is set to match the existing pre-bias voltage and both drivers are enabled. The output voltage is then ramped to the final regulation value at the ramp rate set by the SS pin. The actual time the output will take to ramp from the pre-bias voltage to the target voltage will vary depending on the pre-bias voltage but the total time elapsed from when the delay period expires and when the output reaches its target value will match the pre-configured ramp time. See Figure 17.

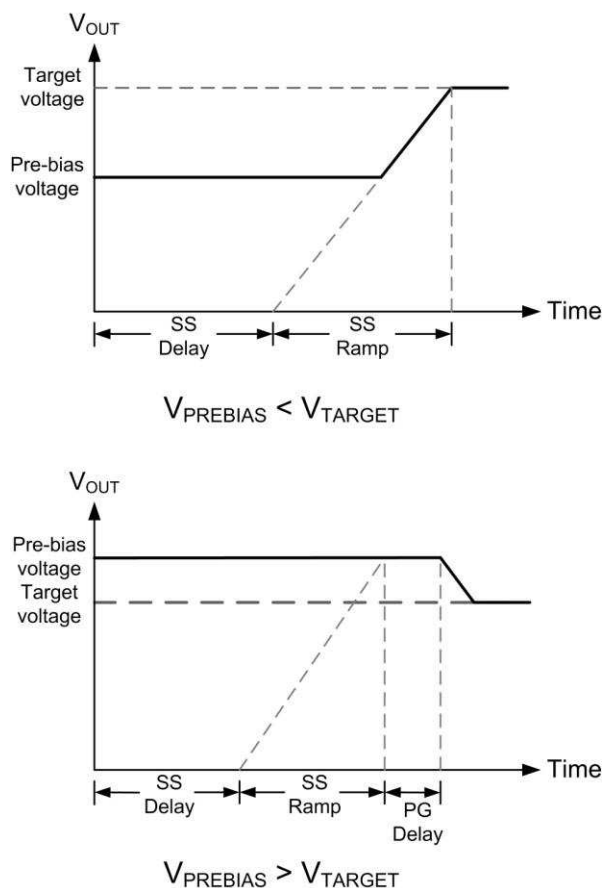

Figure 17. Output Responses to Pre-bias Voltages

If a pre-bias voltage higher than the target voltage exists after the pre-configured delay period has expired, the target voltage is set to match the existing pre-bias voltage and both drivers are enabled with a PWM duty cycle that would ideally create the pre-bias voltage. Once the pre-configured soft-start ramp period has expired, the PG pin will be asserted (assuming the pre-bias voltage is not higher than the overvoltage limit). The PWM will then adjust its duty cycle to match the original target voltage and the output will ramp down to the pre-configured output voltage.

If a pre-bias voltage higher than the overvoltage limit exists, the device will not initiate a turn-on sequence and will declare an overvoltage fault condition to exist. In this case, the device will respond based on the output overvoltage fault response method that has been selected. See Section 6.3 “Output Overvoltage Protection,” for response options due to an overvoltage condition.

6.5 Output Overcurrent Protection

The ZL2105 can protect the power supply from damage if the output is shorted to ground or if an

overload condition is imposed on the output. Once the current limit threshold has been selected (see Section 5.10 “Current Limit Threshold Selection”), the user may determine the desired course of action in response to the fault condition. The following overcurrent protection response options are available:

1. Initiate a shutdown and attempt to restart an infinite number of times with a preset delay period between attempts.
2. Initiate a shutdown and attempt to restart a preset number of times with a preset delay period between attempts.
3. Continue operating for a given delay period, followed by shutdown if the fault still exists.
4. Continue operating through the fault (this could result in permanent damage to the power supply).
5. Initiate an immediate shutdown.

The default response from an overcurrent fault is an immediate shutdown of the device. The device will continuously check for the presence of the fault condition, and if the fault condition no longer exists the device will be re-enabled.

Please refer to Application Note AN2013 for details on how to select specific overcurrent fault response options via I²C/SMBus.

6.6 Thermal Overload Protection

The ZL2105 includes an on-chip thermal sensor that continuously measures the internal temperature of the die and shuts down the device when the temperature exceeds the preset limit. The default temperature limit is set to 125°C in the factory, but the user may set the limit to a different value if desired. The user may select one of the following overtemperature protection response options:

1. Initiate a shutdown and attempt to restart an infinite number of times with a preset delay period between attempts.
2. Initiate a shutdown and attempt to restart a preset number of times with a preset delay period between attempts.
3. Continue operating for a given delay period, followed by shutdown if the fault still exists.

4. Continue operating through the fault (this could result in permanent damage to the power supply).
5. Initiate an immediate shutdown.

If the user has configured the device to restart, the device will wait the preset delay period (if so chosen) and will then check the device temperature. If the temperature has dropped below a threshold that is approx 15°C lower than the selected temperature fault limit, the device will attempt to re-start. If the temperature still exceeds the fault limit the device will wait the preset delay period and retry again.

The default response from a temperature fault is an immediate shutdown of the device. The device will continuously check for the fault condition, and once the fault has cleared the ZL2105 will be re-enabled.

Please refer to Application Note AN2013 for details on how to select specific over-temperature fault response options via I²C/SMBus.

6.7 Voltage Tracking

Numerous high performance systems place stringent demands on the order in which the power supply voltages are turned on. This is particularly true when powering FPGAs, ASICs, and other advanced processor devices that require multiple supply voltages to power a single die. In most cases, the I/O interface operates at a higher voltage than the core and therefore the core supply voltage must not exceed the I/O supply voltage according to the manufacturers' specifications.

Voltage tracking protects these sensitive ICs by limiting the differential voltage between multiple power supplies during the power-up and power down sequence. The ZL2105 integrates a lossless tracking scheme that allows its output to track a voltage that is applied to the VTRK pin with no external components required. The VTRK pin is an analog input that, when tracking mode is enabled, configures the voltage applied to the VTRK pin to act as a reference for the device's output regulation.

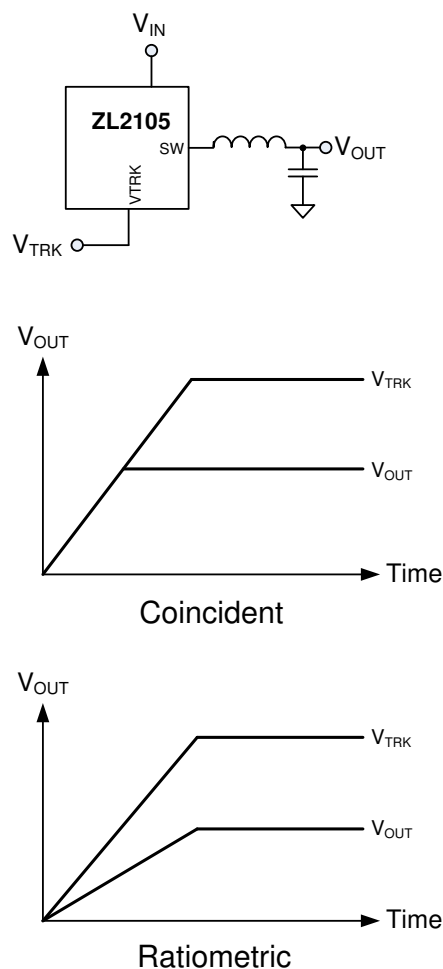

Figure 18. Tracking Modes

Table 22. Tracking Mode Configuration

R_{SS}	Tracking Ratio	Upper Track Limit	Ramp-up/ramp-down Behavior
10 k Ω	100%	Limited by target voltage	Output not allowed to decrease before PG
11 k Ω			Output will always follow VTRK
12.1 k Ω		Limited by VTRK pin voltage	Output not allowed to decrease before PG
13.3 k Ω			Output will always follow VTRK
14.7 k Ω	50%	Limited by target voltage	Output not allowed to decrease before PG
16.2 k Ω			Output will always follow VTRK
17.8 k Ω		Limited by VTRK pin voltage	Output not allowed to decrease before PG
19.6 k Ω			Output will always follow VTRK

The ZL2105 offers two mode of tracking as follows:

1. Coincident. This mode configures the ZL2105 to ramp its output voltage at the same rate as the voltage applied to the VTRK pin.
2. Ratiometric. This mode configures the ZL2105 to ramp its output voltage at a rate that is a percentage of the voltage applied to the VTRK pin. The default setting is 50%, but an external resistor string may be used to configure a different tracking ratio.

Figure 18 illustrates the typical connection and the two tracking modes.

The master ZL2105 device in a tracking group is defined as the device that has the highest target output voltage within the group. This master device will control the ramp rate of all tracking devices and is not configured for tracking mode. A delay of at least 10 ms must be configured into the master device using the DLY pin, and the user may also configure a specific ramp rate using the SS pin. Tracking mode is enabled through the CFG pin as shown in Table 25 on Page 30. Any device that is configured for tracking mode will ignore its soft-start delay and ramp time settings (SS and DLY pins) and its output will take on the turn-on/turn-off characteristics of the reference voltage present at the VTRK pin. The tracking mode for all other devices can be set by connecting a resistor from the SS pin to ground according to Table 22. All of the ENABLE pins in the tracking group must be connected together and driven by a single logic source. Tracking mode can also be configured via the I²C/SMBus interface by using the TRACK_CONFIG PMBus command. Please refer to Application Note AN2013 for more information on configuring tracking mode using PMBus.

6.8 Voltage Margining

The ZL2105 offers a simple means to vary its output higher or lower than its nominal voltage setting in order to determine whether the load device is capable of operating over its specified supply voltage range. The MGN pin is a TTL-compatible input that can be driven directly by a processor I/O pin or other logic-level output.

The ZL2105's output will be forced higher than its nominal set point when the MGN pin is driven HIGH, and the output will be forced lower than its nominal set point when the MGN pin is driven LOW. When the MGN pin is left floating (high impedance), the ZL2105's output voltage will be set to its nominal voltage set point determined by the V0 and V1 pins and/or the I²C/SMBus settings. Default margin limits of $V_{NOM} \pm 5\%$ are pre-loaded in the factory, but the margin limits can be modified through the I²C/SMBus interface to as high as $V_{NOM} + 10\%$ or as low as 0V, where V_{NOM} is the nominal output voltage set point determined by the V0 and V1 pins. A safety feature prevents the user from configuring the output voltage to exceed $V_{NOM} + 10\%$ under any conditions.

The margin limits and the MGN pin command can both be set individually through the I²C/SMBus interface. Additionally, the transition rate between the nominal output voltage and either margin limit can be configured through the I²C interface. Please refer to Application Note AN2013 for detailed instructions on modifying the margining configurations.

6.9 I²C/SMBus Communications

The ZL2105 provides an I²C/SMBus digital interface that enables the user to configure all aspects of the device operation as well as monitor the input and output parameters. The ZL2105 can be used with any standard 2-wire I²C host device. In addition, the device is compatible with SMBus version 2.0 and includes an SALRT line to help mitigate bandwidth limitations related to continuous fault monitoring. Pull-up resistors are required on the I²C/SMBus. The ZL2105 accepts most standard PMBus commands.

6.10 I²C/SMBus Device Address Selection

When communicating with multiple PMBus devices using the I²C/SMBus interface, each device must have its own unique address so the host can distinguish between the devices. The device address can be set according to the pin-strap options listed in Table 23. Address values are right-justified.

Table 23. SMBus Device Address Selection

SA Pin Setting	SMBus Address
LOW	0x20
OPEN	0x21
HIGH	Reserved

If additional device addresses are required, a resistor can be connected to the SA pin according to Table 24 to provide up to 25 unique device addresses.

Table 24. Additional SMBus Address Values

SMBus Address	R _{SA}	SMBus Address	R _{SA}
0x20	10 kΩ	0x2D	34.8 kΩ
0x21	11 kΩ	0x2E	38.3 kΩ
0x22	12.1 kΩ	0x2F	42.2 kΩ
0x23	13.3 kΩ	0x30	46.4 kΩ
0x24	14.7 kΩ	0x31	51.1 kΩ
0x25	16.2 kΩ	0x32	56.2 kΩ
0x26	17.8 kΩ	0x33	61.9 kΩ
0x27	19.6 kΩ	0x34	68.1 kΩ
0x28	21.5 kΩ	0x35	75 kΩ
0x29	23.7 kΩ	0x36	82.5 kΩ
0x2A	26.1 kΩ	0x37	90.9 kΩ
0x2B	28.7 kΩ	0x38	100 kΩ
0x2C	31.6 kΩ		

6.11 Phase Spreading

When multiple point of load converters share a common DC input supply, it is desirable to adjust the clock phase offset of each device such that not all devices start to switch simultaneously. Setting each converter to start its switching cycle at a different point in time can dramatically reduce input capacitance requirements and efficiency losses. Since the peak current drawn from the input supply is effectively spread out over a period of time, the peak current drawn at any given moment is reduced and the power losses proportional to the I_{RMS}^2 are reduced dramatically.

In order to enable phase spreading, all converters must be synchronized to the same switching clock. The CFG pin is used to set the configuration of the SYNC pin for each device as described in Section 5.8 “Switching Frequency and PLL,” on Page 17.

Selecting the phase offset for the device is accomplished by selecting a device address according to the following equation:

$$\text{Phase offset} = \text{device address} \times 45^\circ$$

For example:

- A device address of 0x00 or 0x20 would configure no phase offset
- A device address of 0x01 or 0x21 would configure 45° of phase offset
- A device address of 0x02 or 0x22 would configure 90° of phase offset

The phase offset of each device may also be set to any value between 0° and 337.5° in 22.5° increments via the I²C/SMBus interface. Refer to Application Note AN2013 for further details.

6.12 Output Sequencing

A group of Zilker Labs devices (both ZL2005 and ZL2105) may be configured to power up in a predetermined sequence. This feature is especially useful when powering advanced processors, FPGAs, and ASICs that require one supply to reach its operating voltage prior to another supply reaching its operating voltage in order to avoid latch-up from occurring. Multi-device sequencing can be achieved by configuring each device through the I²C/SMBus interface or by using Zilker Labs patented autonomous sequencing mode.

Autonomous sequencing mode configures sequencing by using events transmitted between devices over the I²C/SMBus pins SCL and SDA. No I²C or SMBus host device is involved in this method, but the SCL and SDA pins must be interconnected between all devices that the user wishes to sequence using this method. (note: pull-up resistors on SCL and SDA are required and should be selected using the criteria in the SMBus 2.0 specification).

The sequencing order is determined using each device's I²C/SMBus device address. Using autonomous sequencing mode (configured using the CFG pin), the devices must exhibit sequential device addresses with no missing addresses in the chain. This mode will also constrain each device to have a phase offset according to its device address as described in Phase Spreading.

The group will turn on in order starting with the device with the lowest address and will continue through to

turn on each device in the address chain until all devices connected have been turned on. When turning off, the device with the highest address will turn off first followed in reverse order by the other devices in the group.

Table 25. CFG Pin Configurations for Sequencing and Tracking

R _{CFG}	SYNC Pin Config	Sequencing Configuration
10 kΩ	Input	Sequencing and Tracking are disabled
11 kΩ	Auto detect	
12.1 kΩ	Output	
14.7 kΩ	Input	Device is the first device in a nested sequencing group. Turn-on order is based on device address.
16.2 kΩ	Auto detect	
17.8 kΩ	Output	
21.5 kΩ	Input	Device is a last device in a nested sequencing group. Turn-on order is based on device address.
23.7 kΩ	Auto detect	
26.1 kΩ	Output	
31.6 kΩ	Input	Device is the middle device in a nested sequencing group. Turn-on order is based on device address.
34.8 kΩ	Auto detect	
38.3 kΩ	Output	
42.2 kΩ	Input	Sequencing is Disabled. Voltage Tracking enabled as defined in Table 22.
46.4 kΩ	Auto detect	
51.1 kΩ	Output	

Sequencing is configured by connecting a resistor from the CFG pin to ground as described in Table 25. The CFG pin is used to set the configuration of the SYNC pin as well as to determine the sequencing method and order. Refer to Section 5.8 “Switching Frequency and PLL,” on Page 17 for more details on the operating parameters of the SYNC pin.

Multiple device sequencing may also be achieved by issuing PMBus commands to assign the preceding device in the sequencing chain as well as the device that will follow in the sequencing chain. This method places fewer restrictions on device address (no need of sequential address) and also allows the user to assign any phase offset to any device irrespective of its device address.

Note: Event based sequencing and fault spreading are broadcast in address groups of up to eight Zilker Labs Digital-DC devices. An address group consists of all devices whose addresses differ in only the three least

significant bits of the address. For example, addresses 0x20, 0x25 and 0x27 are all within the same group. Addresses 0x1F, 0x20 and 0x28 are all in different groups. Device in the same address group can broadcast power on and power down sequencing and fault spreading events with each other. Devices in different group cannot.

The Enable pins of all devices in a sequencing group must be tied together and driven high to initiate a sequenced turn-on of the group. Enable must be driven low to initiate a sequenced turnoff of the group.

Refer to Application Note AN2013 for details on sequencing via the I²C/SMBus interface.

6.13 Monitoring via I²C/SMBus

A system controller can monitor a wide variety of different ZL2105 system parameters through the I²C/SMBus interface. The device can monitor for fault conditions by monitoring the SALRT pin, which will be asserted when any number of pre-configured fault conditions occur.

The device can also be monitored continuously for any number of power conversion parameters including but not limited to the following:

- Input voltage
- Output voltage
- Output current
- Internal junction temperature
- Temperature of an external device
- Switching frequency
- Duty cycle

Please refer to Application Note AN2013 for details on how to monitor specific parameters via the I²C/SMBus interface.

6.14 Temperature Monitoring using the XTEMP Pin

The ZL2105 supports measurement of an external device temperature using either a thermal diode integrated in a processor, FPGA or ASIC, or using a discrete diode-connected NPN transistor such as a 2N3904 or equivalent. Figure 19 illustrates the typical connections required.

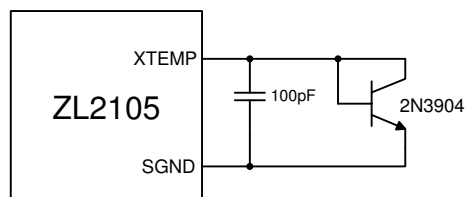

Discrete NPN

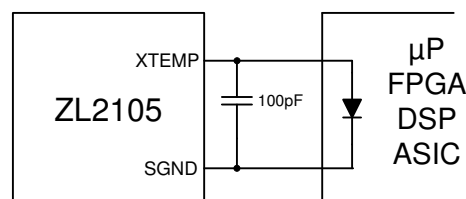

Embedded Thermal Diode

Figure 19. External Temperature Monitoring

6.15 Non-Volatile Memory and Device Security Features

The ZL2105 has internal non-volatile memory where user configurations are stored. Integrated security measures ensure that the user can only restore the device to a level that has been made available to them. Refer to Section 5.6 “Start-up Procedure,” for details on how the device loads stored values from internal memory during start-up. During the initialization process, the ZL2105 checks for stored values contained in its internal memory. The ZL2105 offers two internal memory storage units that are accessible by the user as follows:

1. **Default Store:** A power supply module manufacturer may want to protect the module from damage by preventing the user from being able to modify certain values that are related to the physical construction of the module. In this case, the module manufacturer would use the Default Store and would allow the user to restore the device to its default setting but would restrict the user from restoring the device to the factory settings.
2. **User Store:** The manufacturer of a piece of equipment may want to provide the ability to modify certain power supply settings while still protecting the equipment from modifying values that can lead to a system level fault. The equipment manufacturer would use the User Store to achieve this goal.

Please refer to Application Note AN2013 for details on how to set specific security measures via the I²C/SMBus interface.

7. Package Dimensions

Package Outline Drawing

L36.6x6C

36 LEAD QUAD FLAT NO-LEAD PLASTIC PACKAGE

Rev 0, 4/10

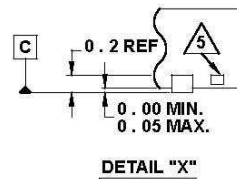
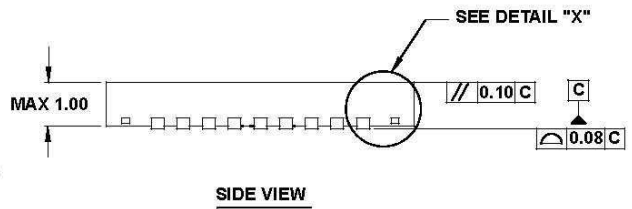
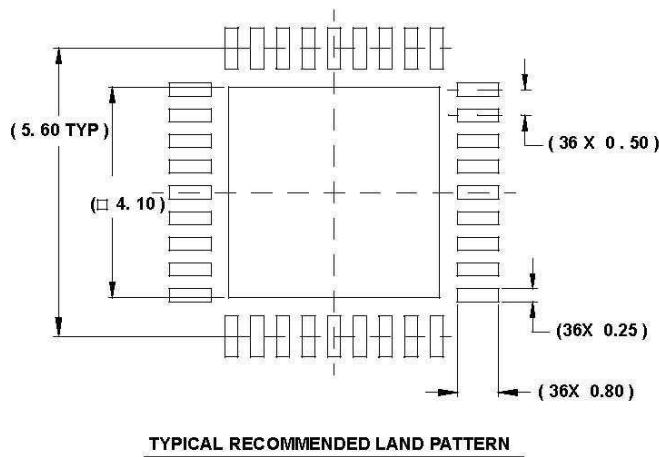
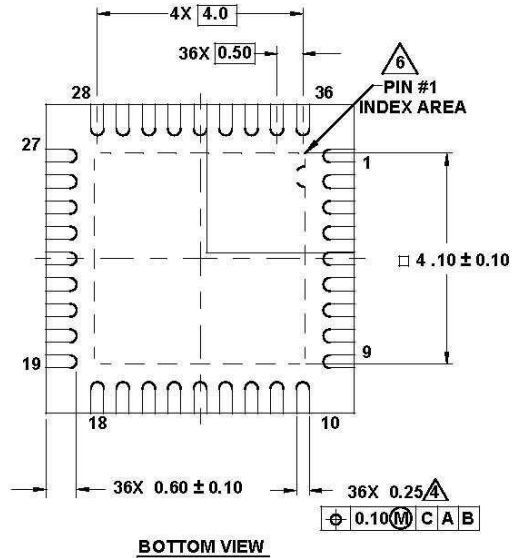
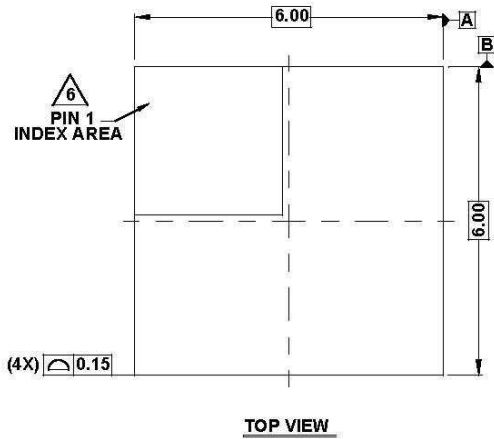

NOTES:

1. Dimensions are in millimeters.
Dimensions in () for Reference Only.
2. Dimensioning and tolerancing conform to ASME Y14.5m-1994.
3. Unless otherwise specified, tolerance : Decimal ± 0.05
4. Dimension applies to the metallized terminal and is measured between 0.15mm and 0.30mm from the terminal tip.
5. Tiebar shown (if present) is a non-functional feature.
6. The configuration of the pin #1 identifier is optional, but must be located within the zone indicated. The pin #1 identifier may be either a mold or mark feature.
7. JEDEC reference drawing: MO-220VJJD.

8. Ordering Information

PART NUMBER (Notes 2, 3)	PART MARKING	TEMP RANGE (°C)	PACKAGE (Pb-free)	PKG. DWG. #
ZL2105ALNF	2105	-40 to +85	36 Ld QFN	L36.6X6C
ZL2105ALNFT (Note 1)	2105	-40 to +85	36 Ld QFN	L36.6X6C
ZL2105ALNFT1 (Note 1)	2105	-40 to +85	36 Ld QFN	L36.6X6C
ZL2105EVK2	Evaluation Board			

Notes:

1. Please refer to [TB347](#) for details on reel specifications.
2. These Intersil Pb-free plastic packaged products employ special Pb-free material sets, molding compounds/die attach materials, and 100% matte tin plate plus anneal (e3 termination finish, which is RoHS compliant and compatible with both SnPb and Pb-free soldering operations). Intersil Pb-free products are MSL classified at Pb-free peak reflow temperatures that meet or exceed the Pb-free requirements of IPC/JEDEC J STD-020
3. For Moisture Sensitivity Level (MSL), please see device information page for [ZL2105](#). For more information on MSL please see techbrief [TB363](#).

9. Related Documentation

The following application support documents and tools are available to help simplify your design.

Item	Description
ZL2105EVK2	Evaluation Kit – 3A Integrated Digital DC-DC Converter
AN2010	Application Note: Thermal and Layout Guidelines for Digital-DC™ Products
AN2011	Application Note: Digital-DC Component Selection Guide
AN2013	Application Note: Zilker Labs PMBus Command Set
AN2016	Application Note: Digital-DC™ Control Loop Compensation

10. Revision History

Rev. #	Description	Date
0.8	Preliminary Release	July 2006
1.0	Updated Table 1 and Table 3 to remove TBDs. Release to production.	4/12/07
1.1	Added R_{FC} to Fig. 3. Added charge pump cap value to Figs. 10 and 11. Added R_{VR} to Figs. 8, 9, 10, and 12. Added SOA curve on Page 9. Added R_{VR} description on Page 20.	5/15/07
1.2	Changed max switching frequency from 2MHz to 1.2MHz Removed R_{FC} from Fig. 3. Updated SOA curve on Page 9. Added ferrite bead to applications circuit on Page 8 Added 100pF cap to temp circuit on Page 30	11/29/07
1.3	Changed max switching frequency from 1.2MHz to 2MHz Updated SOA curves on Page 9.	1/10/08
1.4	Updated Ordering Information on Page 34 Corrected OV response description on Page 25	May 2008
FN6851.0	Assigned file number FN6851 to datasheet as this will be the first release with an Intersil file number. Replaced header and footer with Intersil header and footer. Updated disclaimer information to read "Intersil and its subsidiaries including Zilker Labs, Inc." No changes to datasheet content	February 2009
FN6851.1	Added following statement to disclaimer on page 36: "This product is subject to a license from Power One, Inc. related to digital power technology as set forth in U.S. Patent No. 7,000,125 and other related patents owned by Power One, Inc. These license rights do not extend to stand-alone POL regulators unless a royalty is paid to Power One, Inc."	December 2010
FN6851.2	Page 3, Table 1, 3rd entry, High Side Supply Voltage, changed max value from 30 to 25. Page 4, Table 3, IDSS Shutdown Current, changed Max limit from 1 to 2. Page 4, Table 3, Removed row "Logic input bias current" and replaced with "Logic input current" conditions "EN, SCL, SDA pins" Min -250 Max 250 Unit nA Page 4, Table 3, Removed row "MGN pin current" Pages 4-5, Table 3, Added footnote "Compliance to datasheet limits is assured by one or more methods: production test, characterization and/or design." Page 34, Updated Ordering Information. Added ZL2105ALNF, ZL2105ALNFT1, ZL2105EVK2, tape and reel note, Pb-free note based on lead finish and MSL note. Changed Pkg. Dwg. # from L36.6x6A to L36.6x6C Page 34, corrected Application Note numbers in Related Documentation. Page 33, updated Package Outline Drawing from L36.6x6A to L36.6x6C (Max dimension in Side View changed from 0.90 to 1.00)	March 2011



Zilker Labs, Inc.
900 S. Capital of Texas Highway
Suite 250
Austin, TX 78746
Tel: 512-382-8300
Fax: 512-382-8329

www.intersil.com/zilkerlabs/

© 2008, Zilker Labs, Inc. All rights reserved. Zilker Labs, Digital-DC, and the Zilker Labs Logo are trademarks of Zilker Labs, Inc. All other products or brand names mentioned herein are trademarks of their respective holders.

This document contains information on a product under development. Specifications are subject to change without notice. Pricing, specifications and availability are subject to change without notice. Please see www.zilkerlabs.com for updated information. This product is not intended for use in connection with any high-risk activity, including without limitation, air travel, life critical medical operations, nuclear facilities or equipment, or the like.

The reference designs contained in this document are for reference and example purposes only. THE REFERENCE DESIGNS ARE PROVIDED "AS IS" AND "WITH ALL FAULTS" AND INTERSIL CORPORATION AND ITS SUBSIDIARIES INCLUDING ZILKER LABS, INC. DISCLAIMS ALL WARRANTIES, WHETHER EXPRESS OR IMPLIED. ZILKER LABS SHALL NOT BE LIABLE FOR ANY DAMAGES, WHETHER DIRECT, INDIRECT, CONSEQUENTIAL (INCLUDING LOSS OF PROFITS), OR OTHERWISE, RESULTING FROM THE REFERENCE DESIGNS OR ANY USE THEREOF. Any use of such reference designs is at your own risk and you agree to indemnify Intersil Corporation and its subsidiaries including Zilker Labs, Inc. for any damages resulting from such use.

This product is subject to a license from Power One, Inc. related to digital power technology as set forth in U.S. Patent No. 7,000,125 and other related patents owned by Power One, Inc. These license rights do not extend to stand-alone POL regulators unless a royalty is paid to Power One, Inc.