

450MHz Differential Twisted-Pair Drivers

EL5173, EL5373

The EL5173 and EL5373 are single and triple high bandwidth amplifiers with a fixed gain of 2. They are primarily targeted for applications such as driving twisted-pair lines in component video applications. The inputs can be in either single-ended or differential form but the outputs are always in differential form.

The output common mode level for each channel is set by the associated REF pin, which has a -3dB bandwidth of over 190MHz. Generally, these pins are grounded but can be tied to any voltage reference.

All outputs are short circuit protected to withstand temporary overload condition.

The EL5173 and EL5373 are specified for operation over the full -40°C to +85°C temperature range.

Features

- Fully differential inputs and outputs
- Differential input range $\pm 2.3V$
- 450MHz 3dB bandwidth at fixed gain of 2
- 900V/ μs slew rate (EL5173)
- 1100V/ μs slew rate (EL5373)
- Single 5V or dual $\pm 5V$ supplies
- 40mA maximum output current
- Low power - 12mA per channel
- Pb-free available (RoHS compliant)

Applications

- Twisted-pair drivers
- Differential line drivers
- VGA over twisted-pairs
- ADSL/HDSL drivers
- Single-ended to differential amplification
- Transmission of analog signals in a noisy environment

Pinouts

EL5173
(8 LD SOIC, MSOP)
TOP VIEW

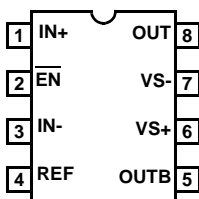

EL5373
(24 LD QSOP)
TOP VIEW

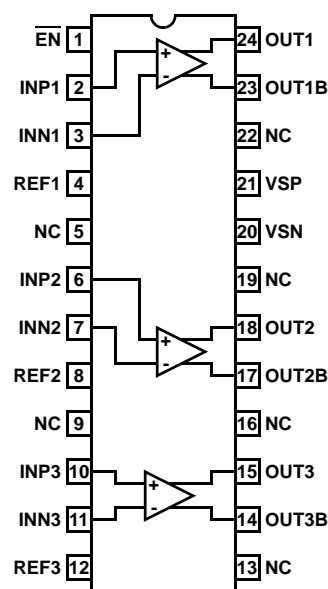

EL5173, EL5373

Pin Descriptions

EL5173		EL5373		PIN FUNCTION
PIN NUMBER	PIN NAME	PIN NUMBER	PIN NAME	
1	IN+	2, 6, 10	INP1, INP2, INP3	Non-inverting inputs
2	$\overline{\text{EN}}$	1	$\overline{\text{EN}}$	$\overline{\text{ENABLE}}$
3	IN-	3, 7, 11	INN1, INN2, INN3	Inverting inputs, note that on EL5173, this pin is also the REF pin
4	REF	4, 8, 12	REF1, REF2, REF3	Reference inputs, sets common-mode output voltage
5	OUTB	14, 17, 23	OUT3B, OUT2B, OUT1B	Inverting outputs
6	VS+	21	VSP	Positive supply
7	VS-	20	VSN	Negative supply
8	OUT	15, 18, 24	OUT3, OUT2, OUT1	Non-inverting outputs
-	NC	5, 9, 13, 16, 19, 22	NC	No connect; grounded for best crosstalk performance

Ordering Information

PART NUMBER (Notes 1, 2, 3)	PART MARKING	PACKAGE (Pb-free)	PKG. DWG. #
EL5173ISZ	5173ISZ	8 Ld SOIC	M8.15E
EL5173IYZ	BAAYA	8 Ld MSOP	M8.118A
EL5373IUZ	EL5373IUZ	24 Ld QSOP	MDP0040

NOTES:

1. Add "-T*" suffix for tape and reel. Please refer to [TB347](#) for details on reel specifications.
2. These Intersil Pb-free plastic packaged products employ special Pb-free material sets, molding compounds/die attach materials, and 100% matte tin plate plus anneal (e3 termination finish, which is RoHS compliant and compatible with both SnPb and Pb-free soldering operations). Intersil Pb-free products are MSL classified at Pb-free peak reflow temperatures that meet or exceed the Pb-free requirements of IPC/JEDEC J STD-020.
3. For Moisture Sensitivity Level (MSL), please see device information page for [EL5173](#), [EL5373](#). For more information on MSL please see tech brief [TB363](#).

EL5173, EL5373

Absolute Maximum Ratings (T_A = +25°C)

Supply Voltage (V _{S+} to V _{S-})	12.6V
Supply Voltage Slew Rate	.1V/μs max.
Supply Voltage Rate-of-rise (dV/dT)	1V/μs
Input Voltage (IN+, IN- to V _{S+} , V _{S-})	V _{S-} - 0.3V to V _{S+} + 0.3V
Differential Input Voltage (IN+ to IN-)	±4.8V
Maximum Output Current	±60mA

Thermal Information

Operating Junction Temperature	+135°C
Recommended Operating Temperature	-40°C to +85°C
Storage Temperature Range	-65°C to +150°C
Power Dissipation	See Curves
Pb-Free Reflow Profile	see link below http://www.intersil.com/pbfree/Pb-FreeReflow.asp

CAUTION: Do not operate at or near the maximum ratings listed for extended periods of time. Exposure to such conditions may adversely impact product reliability and result in failures not covered by warranty.

IMPORTANT NOTE: All parameters having Min/Max specifications are guaranteed. Typ values are for information purposes only. Unless otherwise noted, all tests are at the specified temperature and are pulsed tests, therefore: T_J = T_C = T_A

Electrical Specifications V_{S+} = +5V, V_{S-} = -5V, T_A = +25°C, V_{IN} = 0V, R_{LD} = 200Ω, C_{LD} = 1pF, Unless Otherwise Specified.

PARAMETER	DESCRIPTION	CONDITIONS	MIN (Note 4)	TYP	MAX (Note 4)	UNIT
AC PERFORMANCE						
BW	-3dB Bandwidth			450		MHz
BW	±0.1dB Bandwidth			60		MHz
SR	Slew Rate - EL5173	V _{OUT} = 2V _{P-P} , 20% to 80%	750	900		V/μs
	Slew Rate - EL5373	V _{OUT} = 2V _{P-P} , 20% to 80%	900	1100		V/μs
t _{STL}	Settling Time to 0.1%	V _{OUT} = 2V _{P-P}		10		ns
OS	Overshoot	V _{ODP-P} = 2V		10		%
t _{OVR}	Output Overdrive Recovery Time			10		ns
V _{REF} BW (-3dB)	V _{REF} -3dB Bandwidth	A _V = 1, C _{LD} = 2.7pF		190		MHz
V _{REF} SR+	V _{REF} Slew Rate - Rise	V _{OUT} = 2V _{P-P} , 20% to 80%		200		V/μs
V _{REF} SR-	V _{REF} Slew Rate - Fall	V _{OUT} = 2V _{P-P} , 20% to 80%		125		V/μs
V _N	Input Voltage Noise	f = 10kHz		25		nV/√Hz
HD2	Second Harmonic Distortion	V _{OUT} = 2V _{P-P} , 5MHz		84		dBc
HD2	Second Harmonic Distortion	V _{OUT} = 2V _{P-P} , 20MHz		71		dBc
HD3	Third Harmonic Distortion	V _{OUT} = 2V _{P-P} , 5MHz		62		dBc
HD3	Third Harmonic Distortion	V _{OUT} = 2V _{P-P} , 20MHz		53		dBc
dG	Differential Gain at 3.58MHz	R _{LD} = 300Ω, A _V = 2		0.05		%
dθ	Differential Phase at 3.58MHz	R _{LD} = 300Ω, A _V = 2		0.08		°
e _S	Channel Separation - for EL5373 only	at 1MHz		90		dB
INPUT CHARACTERISTICS						
V _{OS}	Input Referred Offset Voltage			±3	±30	mV
I _{IN}	Input Bias Current (V _{IN} , V _{INB})	EL5173	-21	-11	-5	μA
		EL5373	-21	-13	-5	μA
I _{REF}	INput Bias Current at REF	V _{REF} = +3.2V	1		5	μA
		V _{REF} = -3.2V	-1		+1	μA
Gain	Gain Accuracy	V _{IN} = ±1V	1.97	1.99	2.01	V
R _{IN}	Differential Input Resistance			150		kΩ
C _{IN}	Differential Input Capacitance			1		pF
DMIR	Differential Mode Input Range		±2	±2.3		V

EL5173, EL5373

Electrical Specifications $V_{S+} = +5V$, $V_{S-} = -5V$, $T_A = +25^\circ C$, $V_{IN} = 0V$, $R_{LD} = 200\Omega$, $C_{LD} = 1pF$, Unless Otherwise Specified. (Continued)

PARAMETER	DESCRIPTION	CONDITIONS	MIN (Note 4)	TYP	MAX (Note 4)	UNIT
CMIR+	Common Mode Positive Input Range at V_{IN+} , V_{IN-}		3.1	3.4		V
CMIR-	Common Mode Negative Input Range at V_{IN+} , V_{IN-}			-4.5	-4.2	V
V_{REFIN+}	Reference Input - Positive	$V_{IN+} = V_{IN-} = 0V$	3.3	3.7		V
V_{REFIN-}	Reference Input - Negative	$V_{IN+} = V_{IN-} = 0V$		-3.3	-3	V
V_{REFOS}	Output Offset Relative to V_{REF}		-100	50	+100	mV
CMRR	Input Common Mode Rejection Ratio	$V_{IN} = \pm 2.5V$	60	80		dB
OUTPUT CHARACTERISTICS						
V_{OUT} (EL5173)	Positive Output Voltage Swing	$R_{LD} = 200\Omega$	3.3	3.67		V
	Negative Output Voltage Swing			-3.3	-3	V
V_{OUT} (EL5373)	Positive Output Voltage Swing	$R_{LD} = 200\Omega$	3.7	4		V
	Negative Output Voltage Swing			-3.7	-3.4	V
$I_{OUT(Max)}$	Maximum Output Current	$R_L = 10\Omega$ (EL5173)	± 45	± 55		mA
		$R_L = 10\Omega$ (EL5373)	± 40	± 50		mA
R_{OUT}	Output Impedance			60		m Ω
SUPPLY						
V_{SUPPLY}	Supply Operating Range	V_{S+} to V_{S-}	4.75		11	V
$I_{S(ON)}$	Power Supply Current - Per Channel		9	12	14	mA
$I_{S(OFF)+}$ (EL5173)	Positive Power Supply Current - Disabled	\overline{EN} pin tied to 4.8V	60	80	100	μA
$I_{S(OFF)-}$ (EL5173)	Negative Power Supply Current - Disabled		-150	-120	-90	μA
$I_{S(OFF)+}$ (EL5373)	Positive Power Supply Current - Disabled	\overline{EN} pin tied to 4.8V	0.5	2	10	μA
$I_{S(OFF)-}$ (EL5373)	Negative Power Supply Current - Disabled		-150	-120	-90	μA
PSRR	Power Supply Rejection Ratio	V_S from $\pm 4.5V$ to $\pm 5.5V$	60	73		dB
ENABLE						
t_{EN}	Enable Time			100		ns
t_{DS}	Disable Time			1.2		μs
V_{IH}	\overline{EN} Pin Voltage for Power-Up				$V_{S+} - 1.5$	V
V_{IL}	\overline{EN} Pin Voltage for Shut-Down		$V_{S+} - 0.5$			V
I_{IH-EN}	\overline{EN} Pin Input Current High - Per Channel	At $V_{EN} = 5V$		40	60	μA
I_{IL-EN}	\overline{EN} Pin Input Current Low - Per Channel	At $V_{EN} = 0V$	-5	-2.5		μA

NOTE:

- Parameters with MIN and/or MAX limits are 100% tested at $+25^\circ C$, unless otherwise specified. Temperature limits established by characterization and are not production tested.

Connection Diagrams

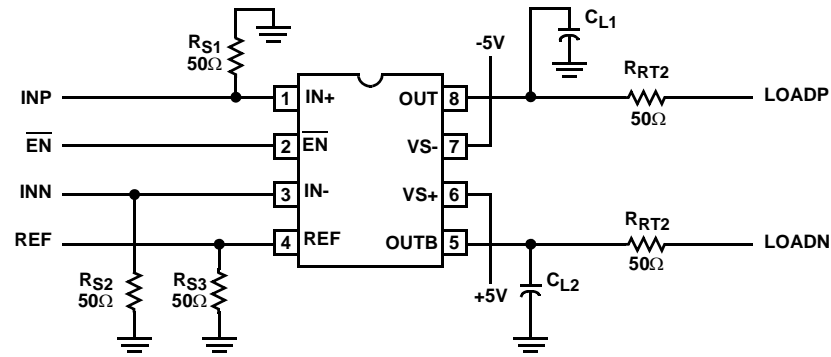

FIGURE 1. EL5173

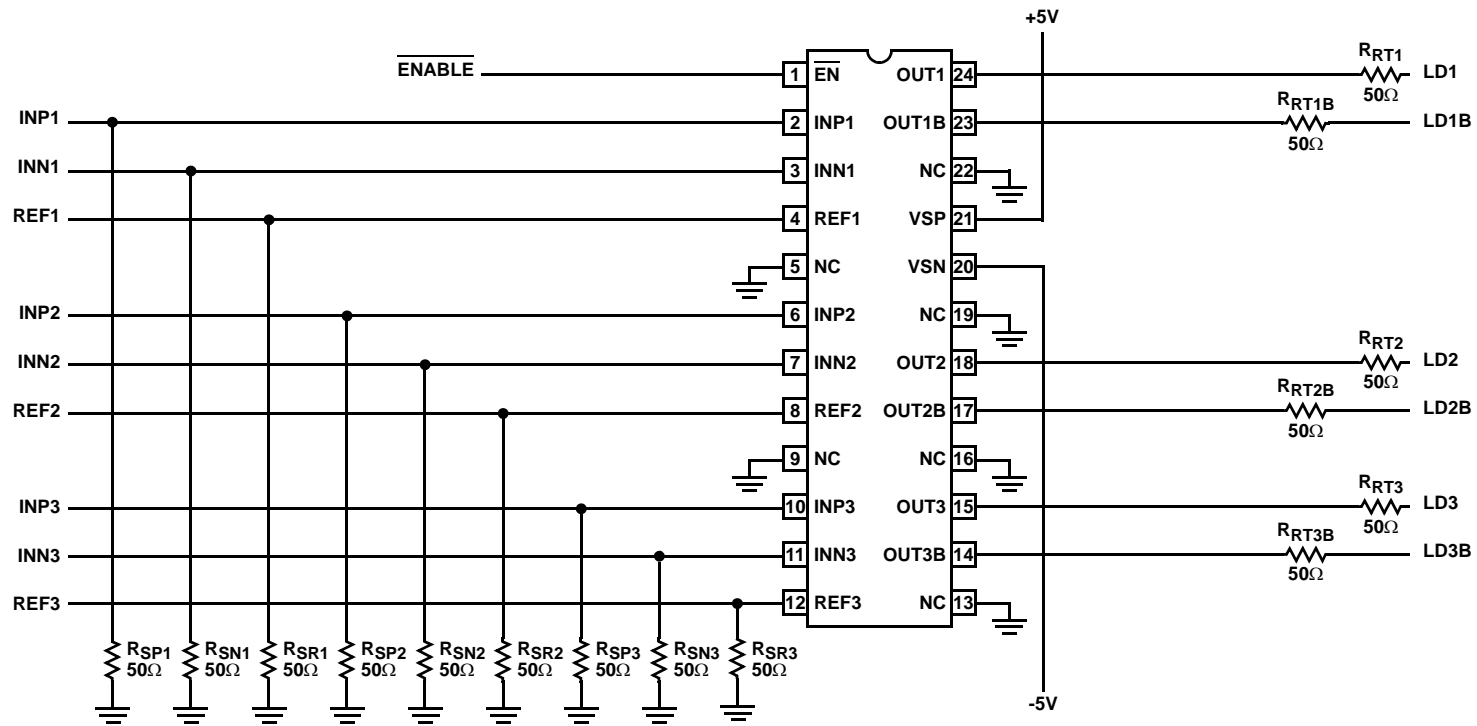

FIGURE 2. EL5373

Typical Performance Curves

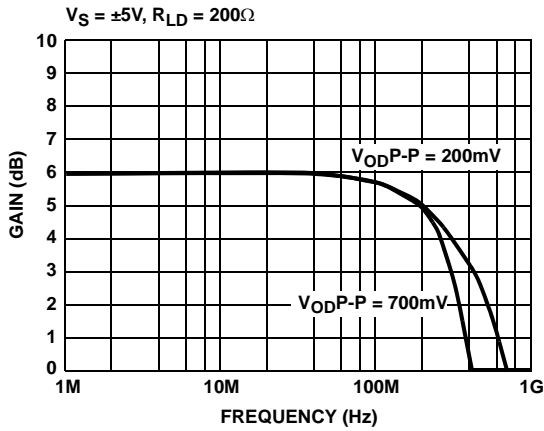

FIGURE 3. FREQUENCY RESPONSE

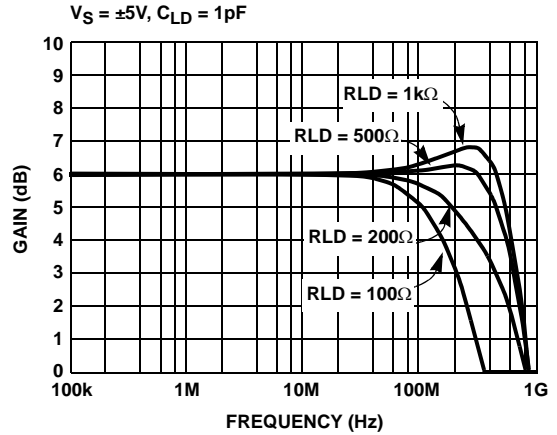

FIGURE 4. FREQUENCY RESPONSE vs R_{LD}

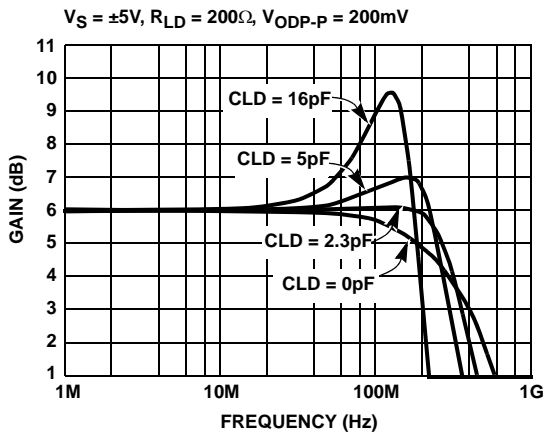

FIGURE 5. SMALL SIGNAL FREQUENCY RESPONSE vs C_{LD}

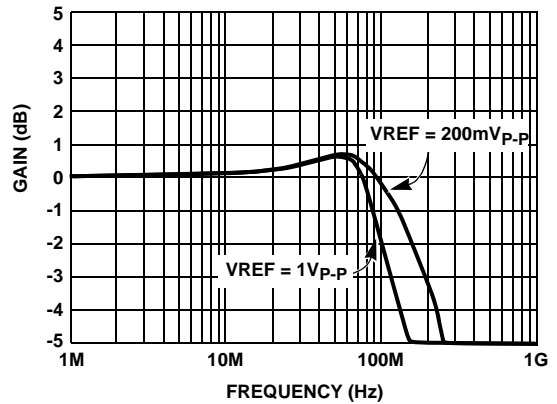

FIGURE 6. FREQUENCY RESPONSE vs V_{REF}

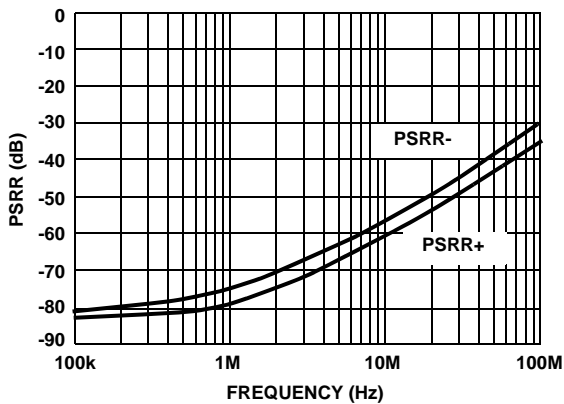

FIGURE 7. PSRR vs FREQUENCY

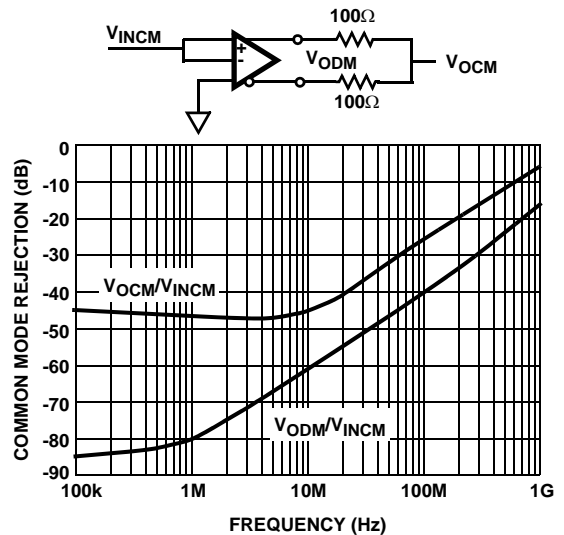

FIGURE 8. COMMON MODE REJECTION vs FREQUENCY

Typical Performance Curves (Continued)

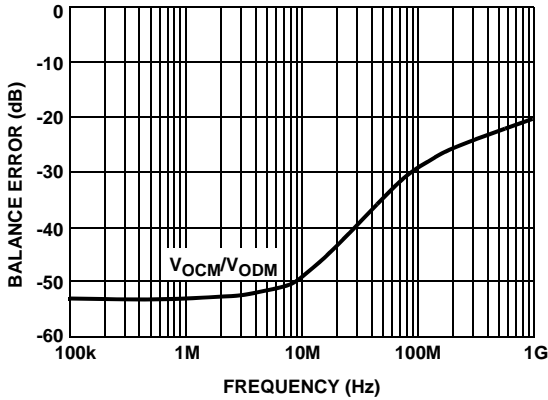
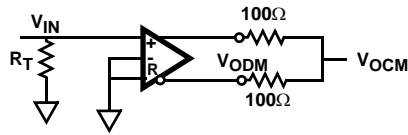

FIGURE 9. DIFFERENTIAL MODE OUTPUT BALANCE ERROR vs FREQUENCY

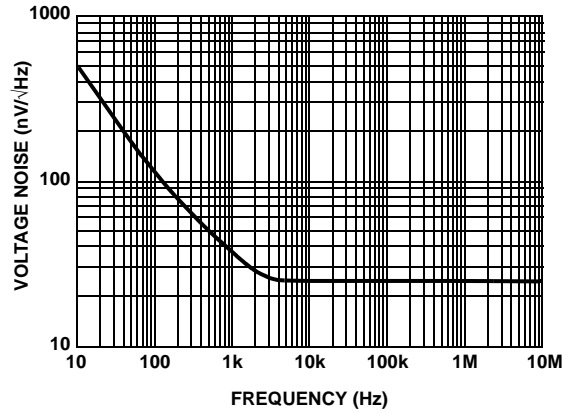

FIGURE 10. INPUT VOLTAGE NOISE vs FREQUENCY

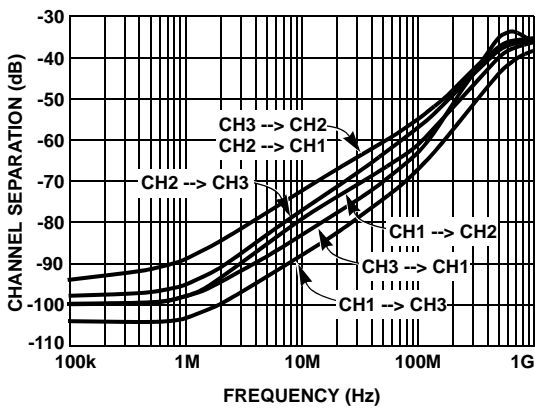

FIGURE 11. CHANNEL SEPARATION vs FREQUENCY

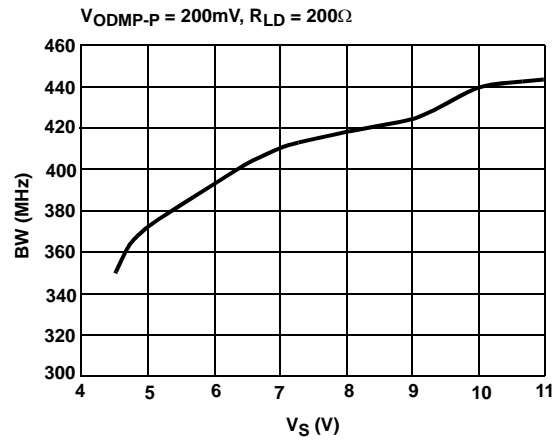

FIGURE 12. SMALL SIGNAL BANDWIDTH vs SUPPLY VOLTAGE

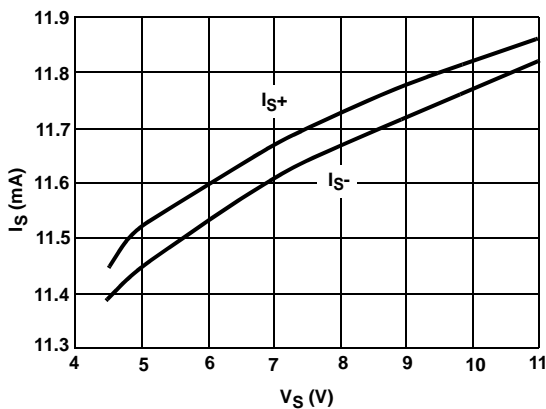

FIGURE 13. SUPPLY CURRENT vs SUPPLY VOLTAGE

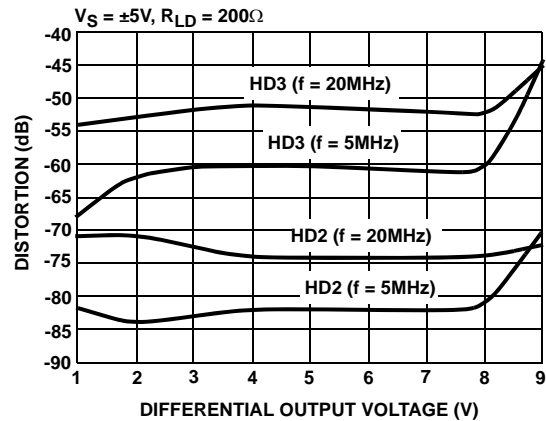

FIGURE 14. HARMONIC DISTORTION vs DIFFERENTIAL OUTPUT VOLTAGE

Typical Performance Curves (Continued)

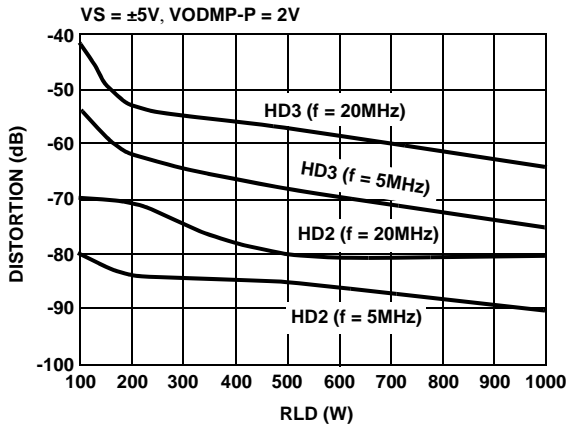

FIGURE 15. HARMONIC DISTORTION vs R_{LD}

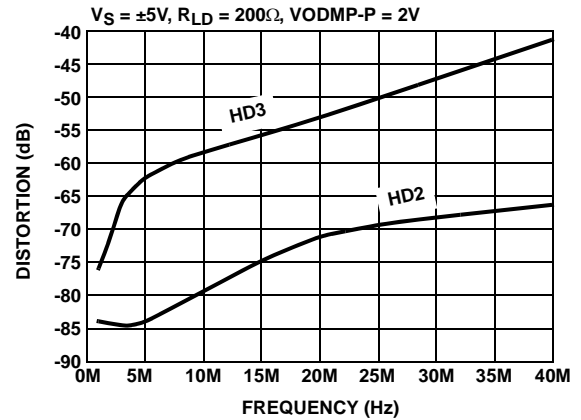

FIGURE 16. HARMONIC DISTORTION vs FREQUENCY

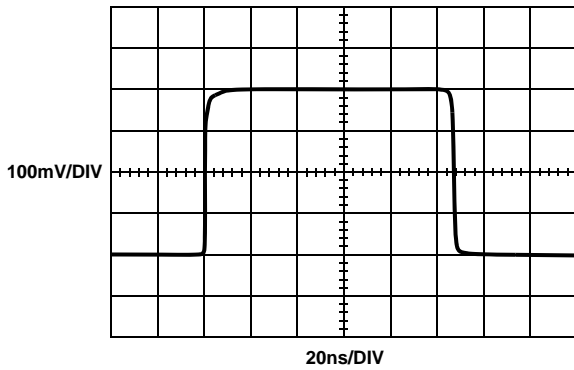

FIGURE 17. SMALL SIGNAL TRANSIENT RESPONSE

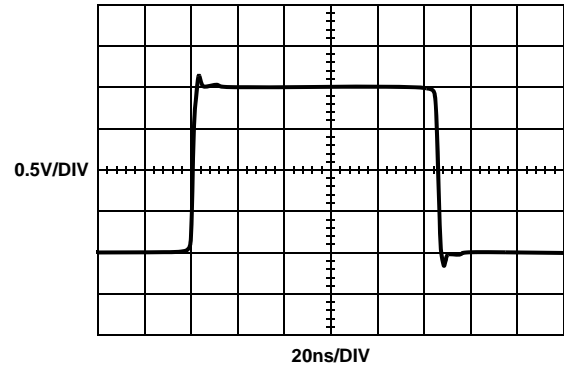

FIGURE 18. LARGE SIGNAL TRANSIENT RESPONSE

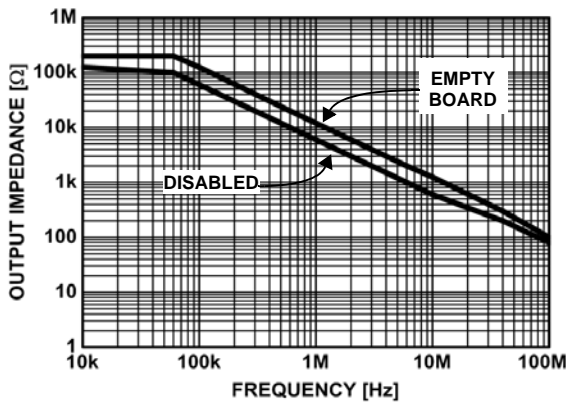

FIGURE 19. OUTPUT IMPEDANCE (DISABLED)

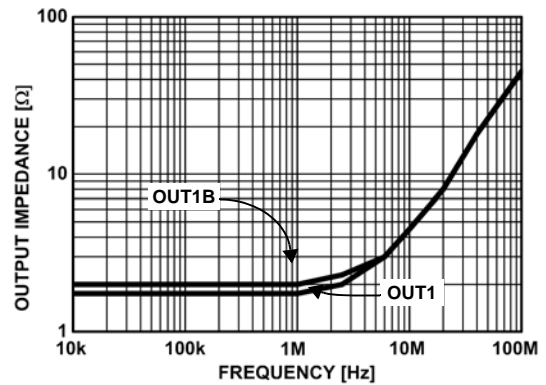

FIGURE 20. OUTPUT IMPEDANCE (ENABLED)

Typical Performance Curves (Continued)

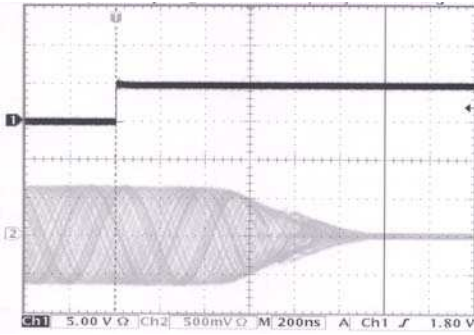

FIGURE 21. DISABLED RESPONSE

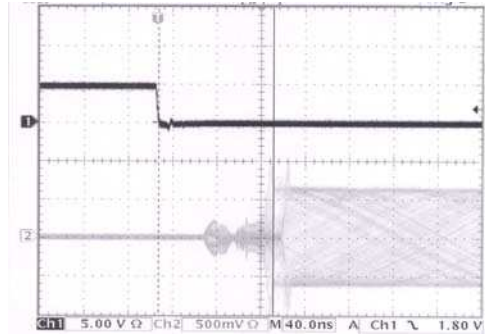

FIGURE 22. ENABLED RESPONSE

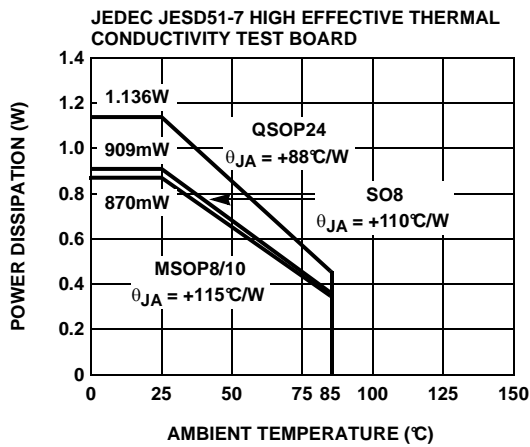

FIGURE 23. PACKAGE POWER DISSIPATION vs AMBIENT TEMPERATURE

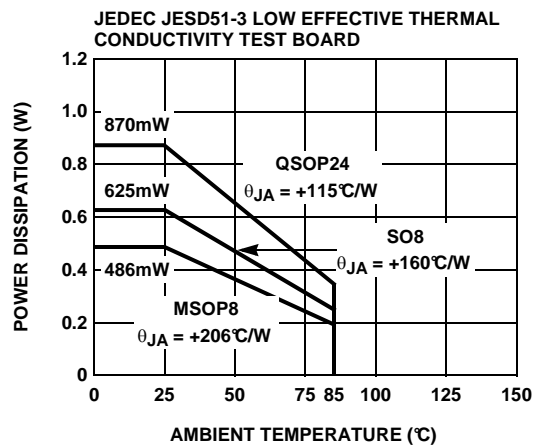
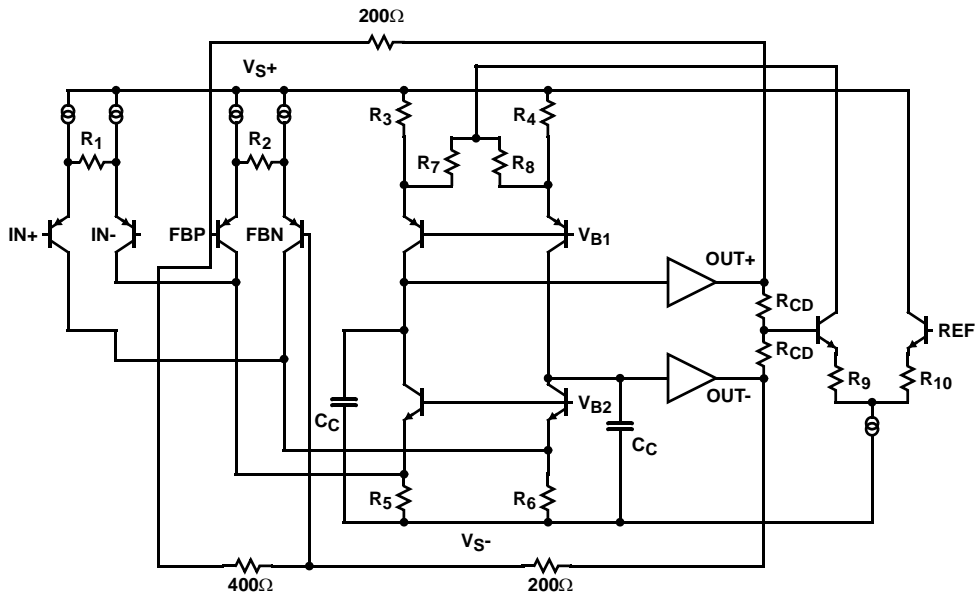

FIGURE 24. PACKAGE POWER DISSIPATION vs AMBIENT TEMPERATURE

Simplified Schematic



Description of Operation and Application Information

Product Description

The EL5173 and EL5373 are wide bandwidth, low power and single/differential ended to differential output amplifiers. They have a fixed gain of 2. The EL5173 is a single channel differential amplifier. The EL5373 is a triple channel differential amplifier. The EL5173 and EL5373 have a -3dB bandwidth of 450MHz while driving a 200Ω differential load. The EL5173 and EL5373 are available with a power-down feature to reduce the power while the amplifiers are disabled.

Input, Output and Supply Voltage Range

The EL5173 and EL5373 have been designed to operate with a single supply voltage of 5V to 10V or split supplies with its total voltage from 5V to 10V. The amplifiers have an input common mode voltage range from -4.5V to 3.4V for ±5V supply. The differential mode input range (DMIR) between the two inputs is from -2.3V to +2.3V. The input voltage range at the REF pin is from -3.3V to 3.7V. If the input common mode or differential mode signal is outside the above-specified ranges, it will cause the output signal to become distorted.

The output of the EL5173 and EL5373 can swing from -3.3V to 3.6V at 200Ω differential load at ±5V supply. As the load resistance becomes lower, the output swing is reduced.

Differential and Common Mode Gain Settings

As shown in the “Simplified Schematic” on page 9, since the feedback resistors RF and the gain resistor are integrated with 200Ω and 400Ω, the EL5173 and EL5373 have a fixed gain of 2. The common mode gain is always one.

Driving Capacitive Loads and Cables

The EL5173 and EL5373 can drive 16pF differential capacitor in parallel with 200Ω differential load with less than 3.5dB of peaking. If less peaking is desired in applications, a small series resistor (usually between 5Ω to 50Ω) can be placed in series with each output to eliminate most peaking. However, this will reduce the gain slightly.

When used as a cable driver, double termination is always recommended for reflection-free performance. For those applications, a back-termination series resistor at the amplifier’s output will isolate the amplifier from the cable and allow extensive capacitive drive. However, other applications may have high capacitive loads without a back-termination resistor. Again, a small series resistor at the output can help to reduce peaking.

Disable/Power-Down

The EL5173 and EL5373 can be disabled and placed their outputs in a high impedance state. The turn-off time is about 1.2μs and the turn-on time is about 100ns. When disabled, the amplifier’s supply current is reduced to 40μA for I_{S+} and 2.5μA for I_{S-} typically, thereby effectively eliminating the power consumption. The amplifier’s power-down can be controlled by standard CMOS signal levels at the ENABLE pin. The applied

logic signal is relative to V_{S+} pin. Letting the $\overline{\text{EN}}$ pin float or applying a signal that is less than 1.5V below V_{S+} will enable the amplifier. The amplifier will be disabled when the signal at $\overline{\text{EN}}$ pin is above V_{S+} - 0.5V.

Output Drive Capability

The EL5173 and EL5373 have internal short circuit protection. Its typical short circuit current is ±55mA. If the output is shorted indefinitely, the power dissipation could easily increase such that the part will be destroyed. Maximum reliability is maintained if the output current never exceeds ±60mA. This limit is set by the design of the internal metal interconnect.

Power Dissipation

With the high output drive capability of the EL5173 and EL5373, it is possible to exceed the +125°C absolute maximum junction temperature under certain load current conditions. Therefore, it is important to calculate the maximum junction temperature for the application to determine if the load conditions or package types need to be modified for the amplifier to remain in the safe operating area.

The maximum power dissipation allowed in a package is determined according to Equation 1:

$$PD_{MAX} = \frac{T_{JMAX} - T_{AMAX}}{\theta_{JA}} \quad (\text{EQ. 1})$$

Where:

- T_{JMAX} = Maximum junction temperature
- T_{AMAX} = Maximum ambient temperature
- θ_{JA} = Thermal resistance of the package

The maximum power dissipation actually produced by an IC is the total quiescent supply current times the total power supply voltage, plus the power in the IC due to the load, or as expressed in Equation 2:

$$PD = i \times \left(V_{STOT} \times I_{SMAX} + (V_{STOT} - \Delta V_O) \times \frac{\Delta V_O}{R_{LD}} \right) \quad (\text{EQ. 2})$$

Where:

V_{STOT} = Total supply voltage = V_{S+} - V_{S-}

I_{SMAX} = Maximum quiescent supply current per channel

ΔV_O = Maximum differential output voltage of the application

R_{LD} = Differential load resistance

I_{LOAD} = Load current

i = Number of channels

By setting the two PD_{MAX} equations equal to each other, we can solve the output current and R_{LOAD} to avoid the device overheat.

Power Supply Bypassing and Printed Circuit Board Layout

As with any high frequency device, a good printed circuit board layout is necessary for optimum performance. Lead lengths should be as short as possible. The power supply pin must be well bypassed to reduce the risk of oscillation. For normal single supply operation, where the V_{S-} pin is connected to the ground plane, a single $4.7\mu\text{F}$ tantalum capacitor in parallel with a $0.1\mu\text{F}$ ceramic capacitor from V_{S+} to GND will suffice. This same capacitor combination should be placed at each supply pin to ground if split supplies are to be used. In this case, the V_{S-} pin becomes the negative supply rail.

For good AC performance, parasitic capacitance should be kept to minimum. Use of wire-wound resistors should be avoided because of their additional series inductance. Use of sockets should also be avoided if possible. Sockets add parasitic inductance and capacitance that can result in compromised performance. Minimizing parasitic capacitance at the amplifier's inverting input pin is very important. The feedback resistor should be placed very close to the inverting input pin. Strip line design techniques are recommended for the signal traces.

Typical Applications

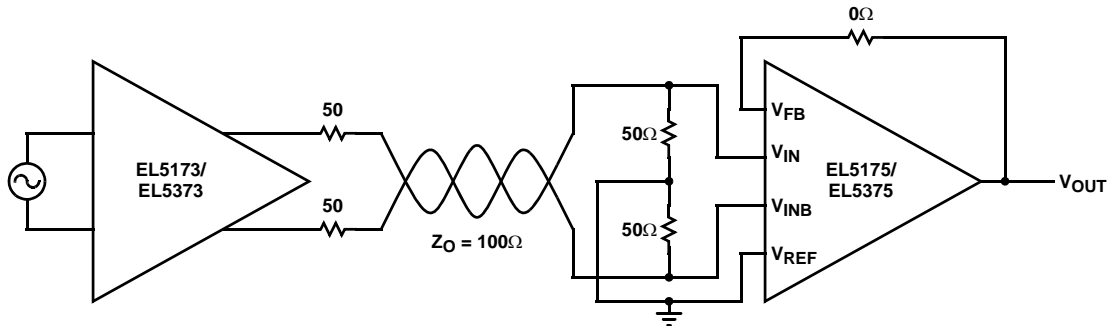

FIGURE 25. TWISTED PAIR CABLE DRIVER

Package Outline Drawing

M8.15E

8 LEAD NARROW BODY SMALL OUTLINE PLASTIC PACKAGE

Rev 0, 08/09

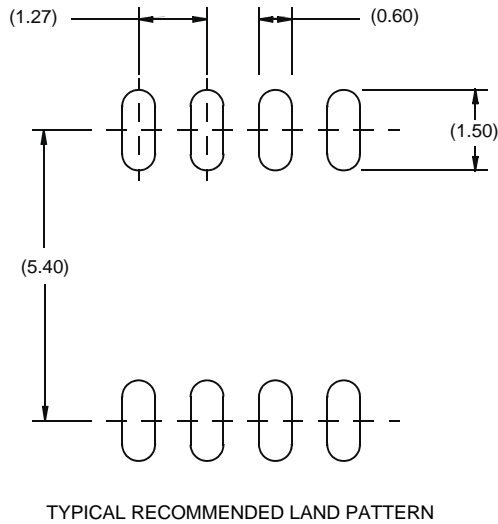
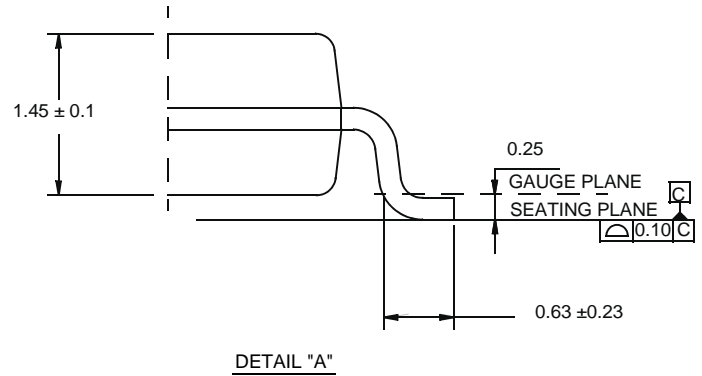
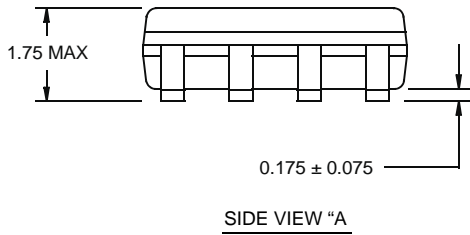
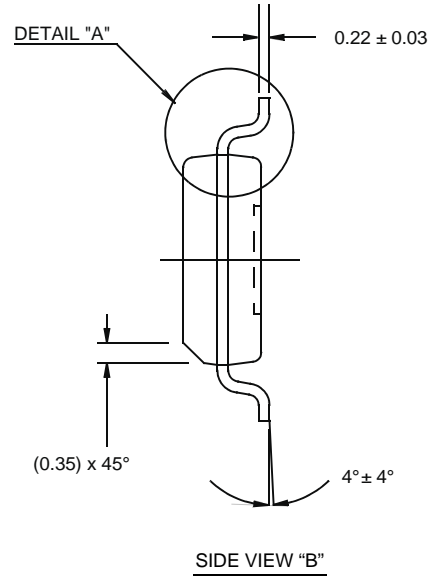
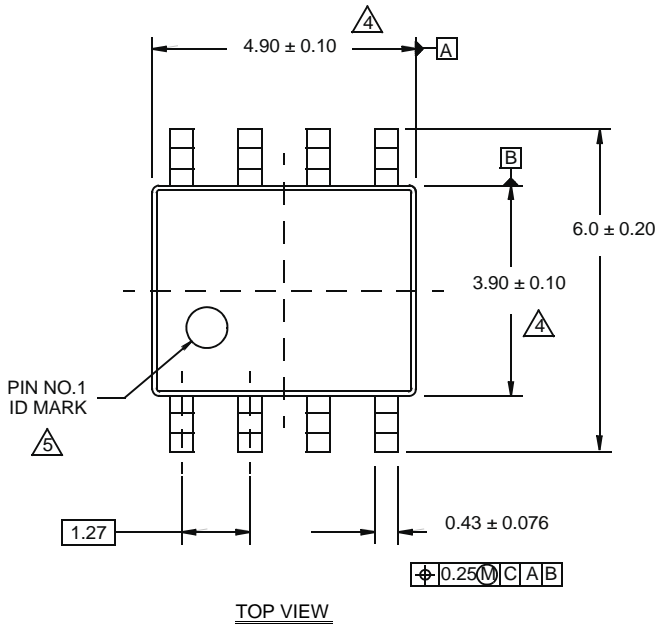

NOTES:

1. Dimensions are in millimeters.
Dimensions in () for Reference Only.
2. Dimensioning and tolerancing conform to AMSE Y14.5m-1994.
3. Unless otherwise specified, tolerance : Decimal ± 0.05
4. Dimension does not include interlead flash or protrusions.
Interlead flash or protrusions shall not exceed 0.25mm per side.
5. The pin #1 identifier may be either a mold or mark feature.
6. Reference to JEDEC MS-012.

Package Outline Drawing

M8.118A

8 LEAD MINI SMALL OUTLINE PLASTIC PACKAGE (MSOP)

Rev 0, 9/09

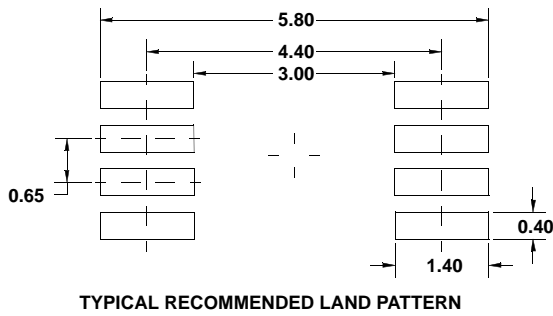
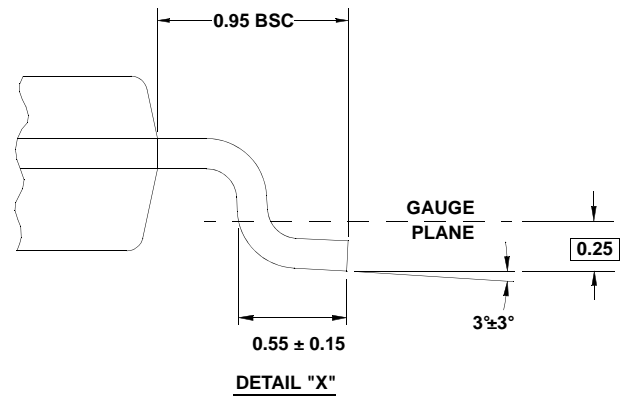
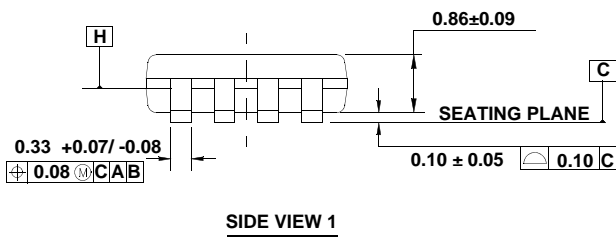
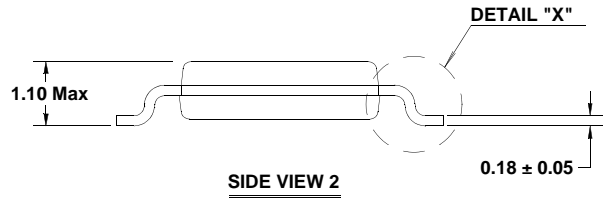
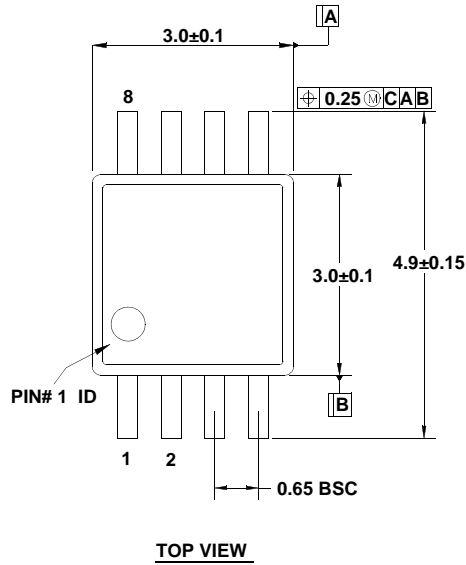

NOTES:

1. Dimensions are in millimeters.
2. Dimensioning and tolerancing conform to JEDEC MO-187-AA and AMSE Y14.5m-1994.
3. Plastic or metal protrusions of 0.15mm max per side are not included.
4. Plastic interlead protrusions of 0.25mm max per side are not included.
5. Dimensions "D" and "E1" are measured at Datum Plane "H".
6. This replaces existing drawing # MDP0043 MSOP 8L.

EL5173, EL5373

Quarter Size Outline Plastic Packages Family (QSOP)

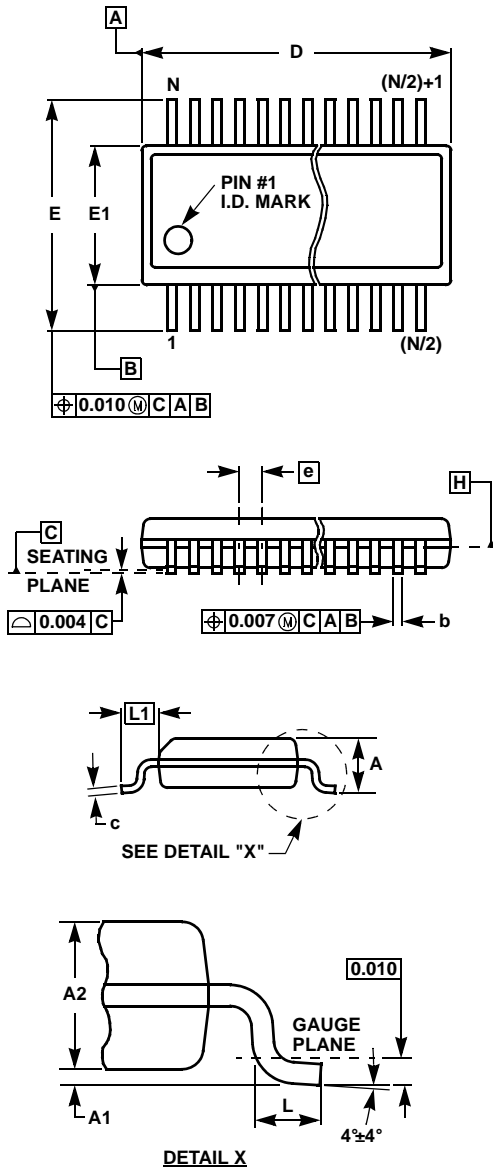

MDP0040

QUARTER SIZE OUTLINE PLASTIC PACKAGES FAMILY

SYMBOL	INCHES			TOLERANCE	NOTES
	QSOP16	QSOP24	QSOP28		
A	0.068	0.068	0.068	Max.	-
A1	0.006	0.006	0.006	± 0.002	-
A2	0.056	0.056	0.056	± 0.004	-
b	0.010	0.010	0.010	± 0.002	-
c	0.008	0.008	0.008	± 0.001	-
D	0.193	0.341	0.390	± 0.004	1, 3
E	0.236	0.236	0.236	± 0.008	-
E1	0.154	0.154	0.154	± 0.004	2, 3
e	0.025	0.025	0.025	Basic	-
L	0.025	0.025	0.025	± 0.009	-
L1	0.041	0.041	0.041	Basic	-
N	16	24	28	Reference	-

Rev. F 2/07

NOTES:

1. Plastic or metal protrusions of 0.006" maximum per side are not included.
2. Plastic interlead protrusions of 0.010" maximum per side are not included.
3. Dimensions "D" and "E1" are measured at Datum Plane "H".
4. Dimensioning and tolerancing per ASME Y14.5M-1994.

For additional products, see www.intersil.com/product_tree

Intersil products are manufactured, assembled and tested utilizing ISO9000 quality systems as noted in the quality certifications found at www.intersil.com/design/quality

Intersil products are sold by description only. Intersil Corporation reserves the right to make changes in circuit design, software and/or specifications at any time without notice. Accordingly, the reader is cautioned to verify that data sheets are current before placing orders. Information furnished by Intersil is believed to be accurate and reliable. However, no responsibility is assumed by Intersil or its subsidiaries for its use; nor for any infringements of patents or other rights of third parties which may result from its use. No license is granted by implication or otherwise under any patent or patent rights of Intersil or its subsidiaries.

For information regarding Intersil Corporation and its products, see www.intersil.com