

0.5MHz, Low Supply Voltage, Low Input Current BiMOS Operational Amplifier

The CA3420 is an integrated circuit operational amplifier that combines PMOS transistors and bipolar transistors on a single monolithic chip. The CA3420 BiMOS operational amplifier features gate protected PMOS transistors in the input circuit to provide very high input impedance, very low input currents (less than 1pA). The internal bootstrapping network features a unique guardbanding technique for reducing the doubling of leakage current for every 10°C increase in temperature. The CA3420 operates at total supply voltages from 2V to 20V either single or dual supply. This operational amplifier is internally phase compensated to achieve stable operation in the unity gain follower configuration. Additionally, it has access terminals for a supplementary external capacitor if additional frequency roll-off is desired. Terminals are also provided for use in applications requiring input offset voltage nulling. The use of PMOS in the input stage results in common mode input voltage capability down to 0.45V below the negative supply terminal, an important attribute for single supply application. The output stage uses a feedback OTA type amplifier that can swing essentially from rail-to-rail. The output driving current of 1.5mA (Min) is provided by using nonlinear current mirrors.

Ordering Information

PART NUMBER	PART MARKING	TEMP. RANGE (°C)	PACKAGE	PKG. DWG. #
CA3420E	CA3420E	-55 to 125	8 Ld PDIP	E8.3
CA3420EZ (Note)	CA3420EZ	-55 to 125	8 Ld PDIP* (Pb-free)	E8.3

*Pb-free PDIPs can be used for through hole wave solder processing only. They are not intended for use in Reflow solder processing applications.

NOTE: Intersil Pb-free plus anneal products employ special Pb-free material sets; molding compounds/die attach materials and 100% matte tin plate termination finish, which are RoHS compliant and compatible with both SnPb and Pb-free soldering operations. Intersil Pb-free products are MSL classified at Pb-free peak reflow temperatures that meet or exceed the Pb-free requirements of IPC/JEDEC J STD-020.

Features

- 2V Supply at 300µA Supply Current
- 1pA Input Current (Typ) (Essentially Constant to 85°C)
- Rail-to-Rail Output Swing (Drive ±2mA into 1kΩ Load)
- Pin Compatible with 741 Operational Amplifiers
- Pb-Free Plus Anneal Available (RoHS Compliant)

Applications

- pH Probe Amplifiers
- Picoammeters
- Electrometer (High Z) Instruments
- Portable Equipment
- Inaccessible Field Equipment
- Battery-Dependent Equipment (Medical and Military)

Functional Diagram

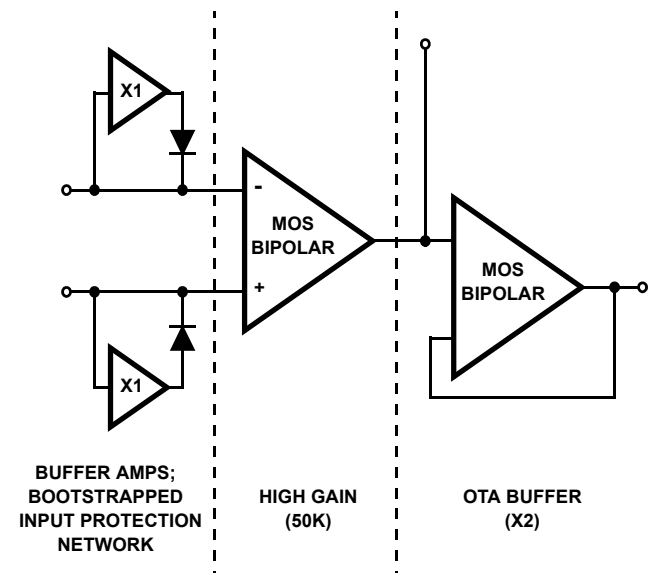

Pinout

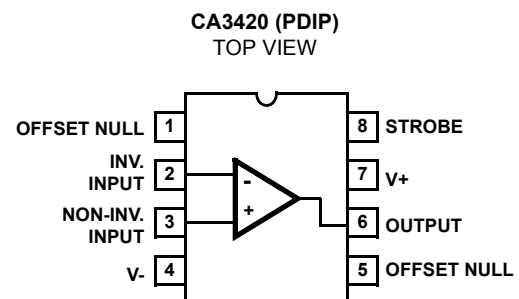

Absolute Maximum Ratings

Supply Voltage (V+ to V-)	.22V
Differential Input Voltage	.15V
DC Input Voltage	(V+ + 8V) to (V- -0.5V)
Input Current	1mA
Output Short Circuit Duration (Note 1)	Indefinite

Operating Conditions

Temperature Range	-55°C to 125°C
-------------------	----------------

Thermal Information

Thermal Resistance (Typical, Note 2)	θ_{JA} (°C/W)	θ_{JC} (°C/W)
PDIP Package*	105	N/A
Maximum Junction Temperature (Plastic Package)	150°C	
Maximum Storage Temperature Range	-65°C to 150°C	
Maximum Lead Temperature (Soldering 10s)	300°C	

*Pb-free PDIPs can be used for through hole wave solder processing only. They are not intended for use in Reflow solder processing applications.

CAUTION: Stresses above those listed in "Absolute Maximum Ratings" may cause permanent damage to the device. This is a stress only rating and operation of the device at these or any other conditions above those indicated in the operational sections of this specification is not implied.

NOTES:

- Short circuit may be applied to ground or to either supply.
- θ_{JA} is measured with the component mounted on an evaluation PC board in free air.

Electrical Specifications Typical Values Intended Only for Design Guidance, $V_{SUPPLY} = \pm 10V$, $T_A = 25^\circ C$

PARAMETER		SYMBOL	TEST CONDITIONS		TYP	UNITS
Input Resistance		R_I			150	$T\Omega$
Input Capacitance		C_I			4.9	pF
Output Resistance		R_O			300	Ω
Equivalent Input Noise Voltage		e_N	f = 1kHz	$R_S = 100\Omega$	62	nV/\sqrt{Hz}
			f = 10kHz		38	nV/\sqrt{Hz}
Short-Circuit Current	Source	I_{OM+}			2.6	mA
To Opposite Supply	Sink	I_{OM-}			2.4	mA
Gain Bandwidth Product		f_T			0.5	MHz
Slew Rate		SR			0.5	V/ μs
Transient Response	Rise Time	t_R	$R_L = 2k\Omega$, $C_L = 100pF$		0.7	μs
	Overshoot	OS			15	%
Current from Terminal 8	To V-	I_{g+}			20	μA
	To V+	I_{g-}			2	mA

Electrical Specifications For Equipment Design, At $V_{SUPPLY} = \pm 1V$, $T_A = 25^\circ C$, Unless Otherwise Specified

PARAMETER	SYMBOL	TEST CONDITIONS	MIN	TYP	MAX	UNITS
Input Offset Voltage	$ V_{IO} $		-	5	10	mV
Input Offset Current (Note 3)	$ I_{IO} $		-	0.01	4	pA
Input Current (Note 3)	$ I_I $		-	1	5	pA
Large Signal Voltage Gain	A_{OL}	$R_L = 10k\Omega$	10	100	-	kV/V
			80	100	-	dB
Common Mode Rejection Ratio	CMRR		-	560	1800	$\mu V/V$
			55	65	-	dB
Common Mode Input Voltage Range	V_{ICR+}		0.2	0.5	-	V
	V_{ICR-}		-	-1.3	-	V
Power Supply Rejection Ratio	PSRR	$\Delta V_{IO}/\Delta V$	-	100	1000	$\mu V/V$
			60	80	-	dB
Max Output Voltage	V_{OM+}	$R_L = \infty$	0.90	0.95	-	V
	V_{OM-}		-0.85	-0.91	-	V
Supply Current	$I+$		-	350	650	μA
Device Dissipation	P_D		-	0.7	1.1	mW
Input Offset Voltage Temperature Drift	$\Delta V_{IO}/\Delta T$		-	4	-	$\mu V/^\circ C$

NOTE:

- The maximum limit represents the levels obtainable on high speed automatic test equipment. Typical values are obtained under laboratory conditions.

Electrical Specifications For Equipment Design, at $V_{SUPPLY} = \pm 10V$, $T_A = 25^\circ C$, Unless Otherwise Specified

PARAMETER	SYMBOL	TEST CONDITIONS	MIN	TYP	MAX	UNITS
Input Offset Voltage	$ V_{IO} $		-	5	10	mV
Input Offset Current (Note 4)	$ I_{IO} $		-	0.03	4	pA
Input Current (Note 4)	$ I_I $		-	0.05	5	pA
Large Signal Voltage Gain	A_{OL}	$R_L = 10k\Omega$	10	100	-	kV/V
			80	100	-	dB
Common Mode Rejection Ratio	CMRR		-	100	320	$\mu V/V$
			70	80	-	dB
Common Mode Input Voltage Range	V_{ICR+}		8.5	9.3	-	V
	V_{ICR-}		-10	-10.3	-	V
Power Supply Rejection Ratio	PSRR	$\Delta V_{IO}/\Delta V$	-	32	320	$\mu V/V$
			70	90	-	dB
Max Output Voltage	V_{OM+}	$R_L = \infty$	9.7	9.9	-	V
	V_{OM-}		-9.7	-9.85	-	V
Supply Current	$I+$		-	450	1000	μA
Device Dissipation	P_D		-	9	14	mW
Input Offset Voltage Temperature Drift	$\Delta V_{IO}/\Delta T$		-	4	-	$\mu V/^\circ C$

NOTE:

- 4. The maximum limit represents the levels obtainable on high speed automatic test equipment. Typical values are obtained under laboratory conditions.

Typical Applications

Picoammeter Circuit

The exceptionally low input current (typically 0.2pA) makes the CA3420 highly suited for use in a picoammeter circuit. With only a single 10GΩ resistor, this circuit covers the range from ±1.5pA. Higher current ranges are possible with suitable switching techniques and current scaling resistors. Input transient protection is provided by the 1MΩ resistor in series with the input. Higher current ranges require that this resistor be reduced. The 10MΩ resistor connected to pin 2 of the CA3420 decouples the potentially high input capacitance often associated with lower current circuits and reduces the tendency for the circuit to oscillate under these conditions.

High Input Resistance Voltmeter

Advantage is taken of the high input impedance of the CA3420 in a high input resistance DC voltmeter. Only two 1.5V "AA" type penlite batteries power this exceedingly high-input resistance (>1,000,000MΩ) DC voltmeter. Full-scale deflection is ±500mV, ±150mV, and ±15mV. Higher voltage ranges are easily added with external input voltage attenuator networks.

The meter is placed in series with the gain network, thus eliminating the meter temperature coefficient error term.

Supply current in the standby position with the meter undeflected is 300μA. At full-scale deflection this current rises to 800μA. Carbon-zinc battery life should be in excess of 1,000 hours.

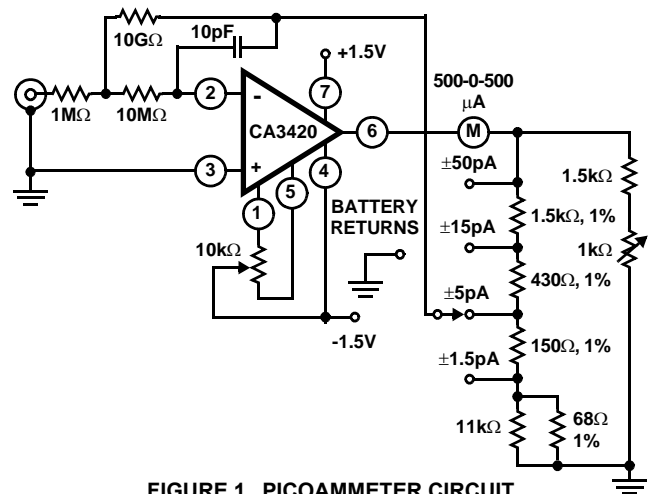

FIGURE 1. PICOAMMETER CIRCUIT

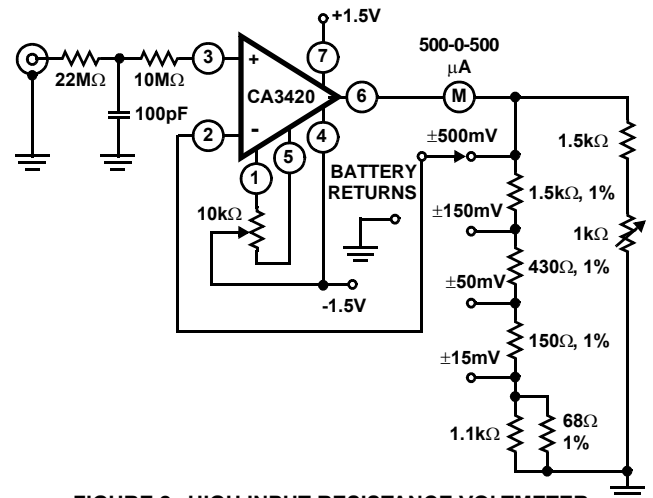

FIGURE 2. HIGH INPUT RESISTANCE VOLTMETER

Typical Performance Curves

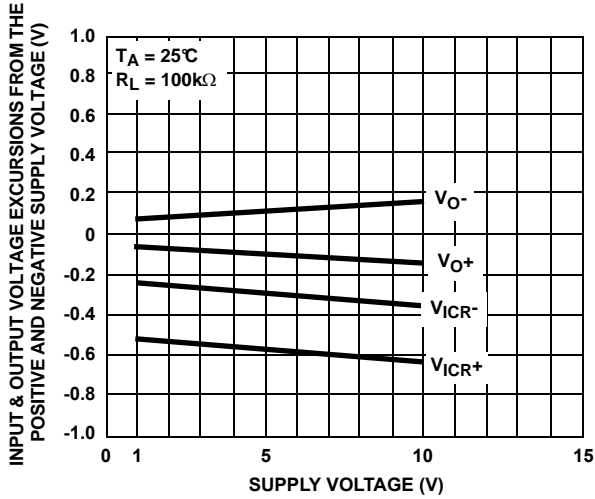

FIGURE 3. OUTPUT VOLTAGE SWING AND COMMON MODE INPUT VOLTAGE RANGE vs SUPPLY VOLTAGE

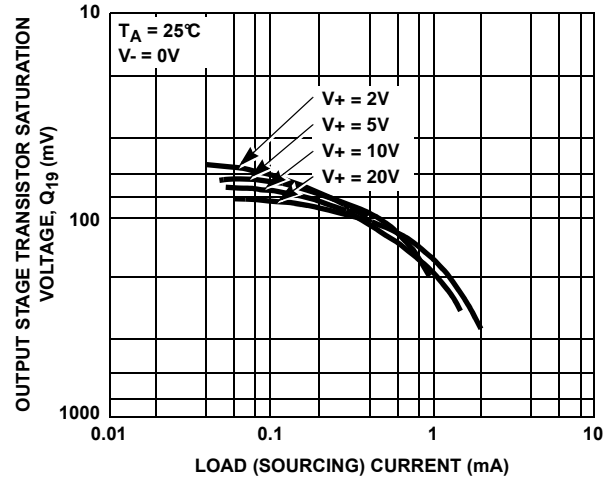

FIGURE 4. OUTPUT VOLTAGE vs LOAD SOURCING CURRENT

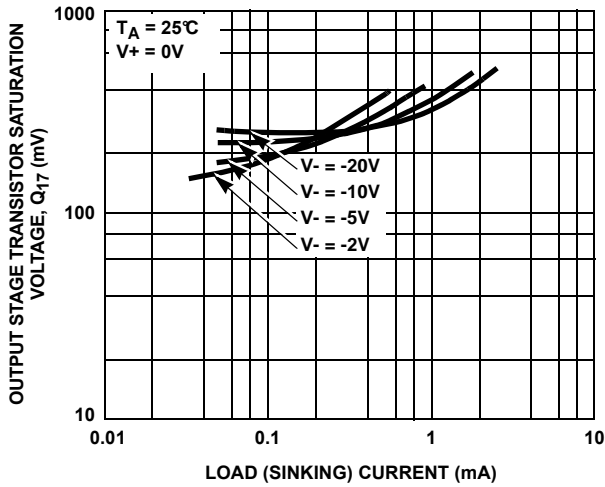

FIGURE 5. OUTPUT VOLTAGE vs LOAD SINKING CURRENT

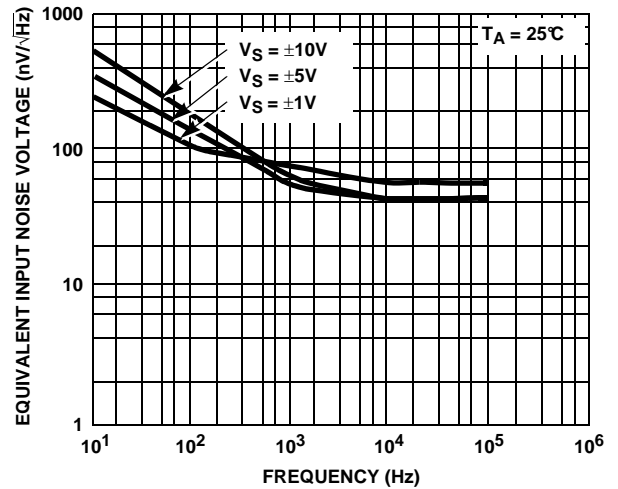

FIGURE 6. INPUT NOISE VOLTAGE vs FREQUENCY

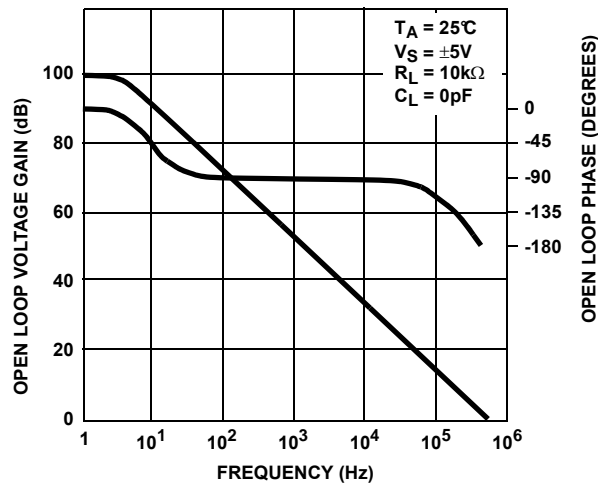
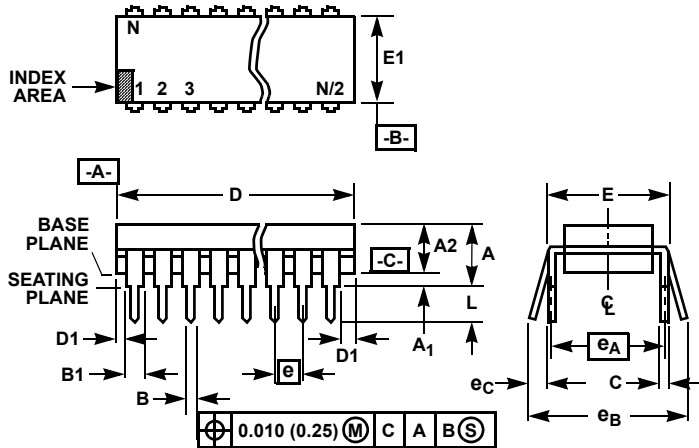

FIGURE 7. OPEN LOOP GAIN AND PHASE SHIFT RESPONSE

Dual-In-Line Plastic Packages (PDIP)



NOTES:

- Controlling Dimensions: INCH. In case of conflict between English and Metric dimensions, the inch dimensions control.
- Dimensioning and tolerancing per ANSI Y14.5M-1982.
- Symbols are defined in the "MO Series Symbol List" in Section 2.2 of Publication No. 95.
- Dimensions A, A1 and L are measured with the package seated in JEDEC seating plane gauge GS-3.
- D, D1, and E1 dimensions do not include mold flash or protrusions. Mold flash or protrusions shall not exceed 0.010 inch (0.25mm).
- E and e_A are measured with the leads constrained to be perpendicular to datum $-C-$.
- e_B and e_C are measured at the lead tips with the leads unconstrained. e_C must be zero or greater.
- B1 maximum dimensions do not include dambar protrusions. Dambar protrusions shall not exceed 0.010 inch (0.25mm).
- N is the maximum number of terminal positions.
- Corner leads (1, N, N/2 and N/2 + 1) for E8.3, E16.3, E18.3, E28.3, E42.6 will have a B1 dimension of 0.030 - 0.045 inch (0.76 - 1.14mm).

E8.3 (JEDEC MS-001-BA ISSUE D)
8 LEAD DUAL-IN-LINE PLASTIC PACKAGE

SYMBOL	INCHES		MILLIMETERS		NOTES
	MIN	MAX	MIN	MAX	
A	-	0.210	-	5.33	4
A1	0.015	-	0.39	-	4
A2	0.115	0.195	2.93	4.95	-
B	0.014	0.022	0.356	0.558	-
B1	0.045	0.070	1.15	1.77	8, 10
C	0.008	0.014	0.204	0.355	-
D	0.355	0.400	9.01	10.16	5
D1	0.005	-	0.13	-	5
E	0.300	0.325	7.62	8.25	6
E1	0.240	0.280	6.10	7.11	5
e	0.100 BSC		2.54 BSC		-
e_A	0.300 BSC		7.62 BSC		6
e_B	-	0.430	-	10.92	7
L	0.115	0.150	2.93	3.81	4
N	8		8		9

Rev. 0 12/93

All Intersil U.S. products are manufactured, assembled and tested utilizing ISO9000 quality systems.
Intersil Corporation's quality certifications can be viewed at www.intersil.com/design/quality

Intersil products are sold by description only. Intersil Corporation reserves the right to make changes in circuit design, software and/or specifications at any time without notice. Accordingly, the reader is cautioned to verify that data sheets are current before placing orders. Information furnished by Intersil is believed to be accurate and reliable. However, no responsibility is assumed by Intersil or its subsidiaries for its use; nor for any infringements of patents or other rights of third parties which may result from its use. No license is granted by implication or otherwise under any patent or patent rights of Intersil or its subsidiaries.

For information regarding Intersil Corporation and its products, see www.intersil.com