

Audio/ USB 2.0 Wired-OR Switch with Click and Pop Reduction

ISL54409, ISL54410

The Intersil ISL54409 and ISL54410 are Dual SPST (Single Pole/Single Throw) switches that provide a very low distortion audio path for a stereo headphone and can be connected in a wired-OR configuration at the switch outputs with USB2.0 HS signals for Audio/USB signal multiplexing to a common connector. The audio switch path can be disabled to provide high signal isolation, preventing crosstalk between the audio codec and USB data signals.

The ISL54409 and ISL54410 analog switches are negative swing capable with a single supply voltage and maintain excellent THD performance within a signal range of -1V to +1V. The switch terminals have low pin capacitance (4pF typical), minimizing impact to USB 2.0 High-Speed signals. The ISL54409 offers a Low Power Shutdown mode while the ISL54410 offers a High Off-Isolation mode. The ISL54410 contains active Audio Click and Pop Elimination circuitry for AC-coupled audio signals.

The ISL54409 and ISL54410 are available in a 8 Ld TDFN (2mmx2mm) or a 10 Ld μ TQFN (1.8mmx1.4mm) package. They operate over a temperature range of -40 to +85°C.

Features

- Single Supply Operation (V_{DD}) . . . +2.7V to +5.0V
- Negative Signal Handling (See “Audio/USB wired-OR Application” on page 8 on protecting USB controller)
- Low OFF Capacitance for HS USB 4pF
- Power Off Protection
- THD+ N at 1mW into 32 Ω Load <0.02%
- Audio Muting >110dB
- Low Power Consumption. 21 μ W with 3V supply
- Low Power Shutdown Mode (ISL54409)
- Active Click and Pop Elimination Circuitry (ISL54410)
- USB V_{BUS} Hot Plug Operation
- Available in 8 Ld TDFN (2mmx2mm) or 10 Ld μ TQFN (1.8mmx1.4mm) Package

Applications* (see page 11)

- Consumer Entertainment Systems
- MP3 and other Personal Media Players
- Cellular/Mobile Phones and PDAs

Related Literature* (see page 11)

- Technical Brief TB363 “Guidelines for Handling and Processing Moisture Sensitive Surface Mount Devices (SMDs)”

Typical Application

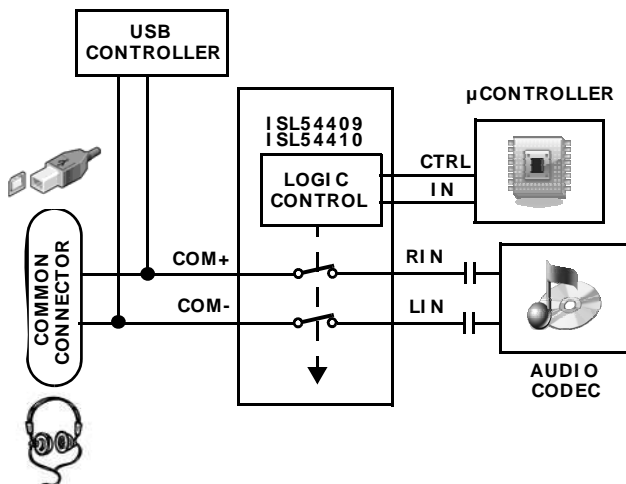

USB2.0 HS Eye Diagram

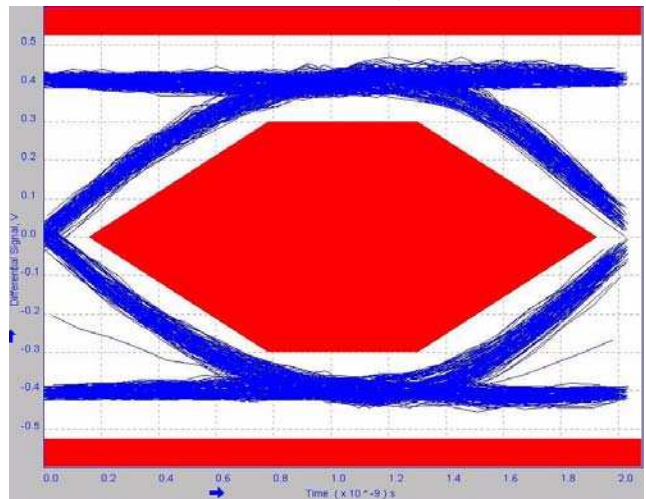

Application Block Diagrams

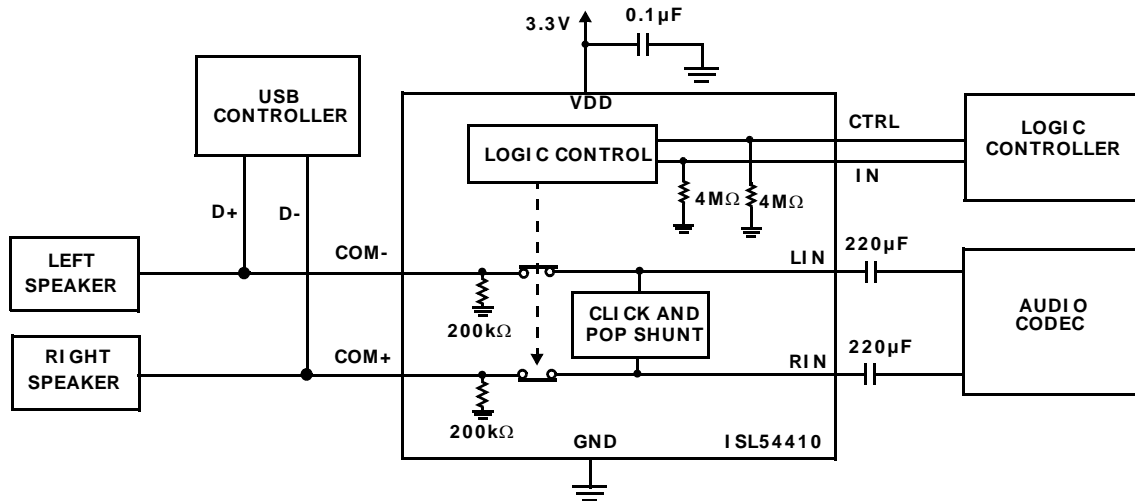
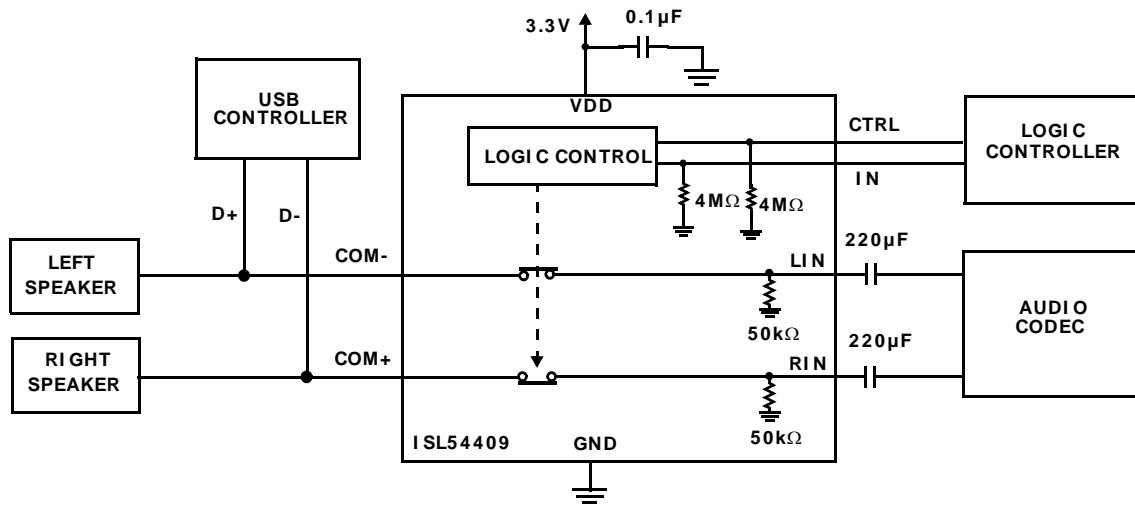
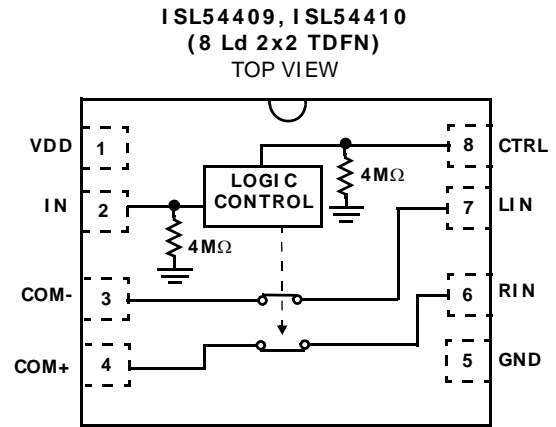
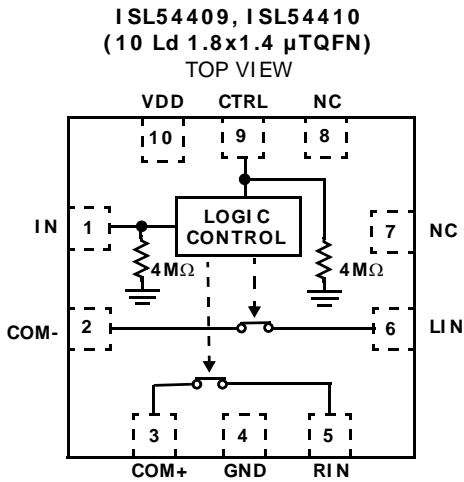

TABLE 1. ISL54409, ISL54410 FEATURES

PART NUMBER	ANALOG SIGNAL RANGE	PACKAGE	LOW POWER MODE	CLICK AND POP ELIMINATION	V _{BUS} HOT PLUG OPERATION
ISL54409	-1 TO +1V	8 Ld TDFN, 10 Ld µTQFN	Yes	No	Yes
ISL54410	-1 TO +1V	8 Ld TDFN, 10 Ld µTQFN	No	Yes	Yes

Pin Configurations (Note 1)



NOTE:

1. Switches shown with IN = 0 and CTRL = 1.

Pin Descriptions

ISL54409 and ISL54410			
TDFN	μ TQFN	NAME	FUNCTION
1	10	VDD	Power Supply
2	1	IN	Logic Control; Internal 4M Ω pull down
3	2	COM-	Audio Left Output
4	3	COM+	Audio Right Output
5	4	GND	IC Ground Connection
6	5	RIN	Audio Right Input
7	6	LIN	Audio Left Input
-	7	NC	Not Connected
-	8	NC	Not Connected
8	9	CTRL	Logic Control; Internal 4M Ω pull-down
PD	-	Pad	Thermal Pad; Connect to GND Plane

Truth Tables

ISL54409			
IN	CTRL	COM-/ COM+	MODE
0	0	OFF	Low Power
0	1	ON	Audio
1	X	OFF	Mute

CTRL and IN: Logic "0" when $\leq 0.5V$, Logic "1" when $\geq 1.4V$

ISL54410			
IN	CTRL	COM-/ COM+	MODE
0	0	OFF	Click and Pop
0	1	ON	Audio
1	X	OFF	Mute

CTRL and IN: Logic "0" when $\leq 0.5V$, Logic "1" when $\geq 1.4V$

Ordering Information

PART NUMBER (Note 2)	PART MARKING	TEMP. RANGE (°C)	PACKAGE Tape & Reel (Pb-Free)	PKG. DWG. #
ISL54409IRTZ-T (Note 3)	409	-40 to +85	8 Ld 2x2 TDFN	L8.2x2C
ISL54409IRUZ-T (Note 4)	U2	-40 to +85	10 Ld 1.8x1.4 µTQFN	L10.1.8x1.4A
ISL54410IRTZ-T (Note 3)	410	-40 to +85	8 Ld 2x2 TDFN	L8.2x2C
ISL54410IRUZ-T (Note 4)	U3	-40 to +85	10 Ld 1.8x1.4 µTQFN	L10.1.8x1.4A
ISL54409EVAL1Z	Evaluation Board			

NOTES:

- Please refer to [TB347](#) for details on reel specifications.
- These Intersil Pb-free plastic packaged products employ special Pb-free material sets, molding compounds/die attach materials, and 100% matte tin plate plus anneal (e3 termination finish, which is RoHS compliant and compatible with both SnPb and Pb-free soldering operations). Intersil Pb-free products are MSL classified at Pb-free peak reflow temperatures that meet or exceed the Pb-free requirements of IPC/JEDEC J STD-020.
- These Intersil Pb-free plastic packaged products employ special Pb-free material sets; molding compounds/die attach materials and NiPdAu plate - e4 termination finish, which is RoHS compliant and compatible with both SnPb and Pb-free soldering operations. Intersil Pb-free products are MSL classified at Pb-free peak reflow temperatures that meet or exceed the Pb-free requirements of IPC/JEDEC J STD-020.
- For Moisture Sensitivity Level (MSL), please see device information page for [ISL54409](#), [ISL54410](#). For more information on MSL please see techbrief [TB363](#).

Absolute Maximum Ratings

VDD to GND	-0.3V to 5.5V
Input Voltages	
LIN, RIN (Note 6)	-2V to ((VDD) + 0.3V)
IN, CTRL (Note 6)	-0.3V to ((VDD) + 0.3V)
Output Voltages	
COM-, COM+ (Note 6)	-2V to ((VDD) + 0.3V)
Continuous Current (LIN, RIN)	±150mA
Peak Current (LIN, RIN)	
(Pulsed 1ms, 10% Duty Cycle, Max)	±300mA
ESD Ratings:	
Human Body Model	
ISL54409	3.5kV
ISL54410	6kV
Machine Model	
ISL54409	250V
ISL54410	300V
Charged Device Model	2kV

Thermal Information

Thermal Resistance (Typical)	θ_{JA} (°C/W)	θ_{JC} (°C/W)
1.8x1.4mm μ TQFN (Notes 7, 8)	160	61.9
2mmx2mm TDFN (Notes 7, 8)	84	10
Maximum Junction Temperature (Plastic Package)	+150°C	
Storage Temperature Range	-65°C to +150°C	
Pb-Free Reflow Profile	see link below	
	http://www.intersil.com/pbfree/Pb-FreeReflow.asp	

Recommended Operating Conditions

Temperature	-40°C to +85°C
-------------	----------------

CAUTION: Do not operate at or near the maximum ratings listed for extended periods of time. Exposure to such conditions may adversely impact product reliability and result in failures not covered by warranty.

NOTES:

- Signals on LIN, RIN, COM-, COM+, IN and CTRL exceeding VDD or GND by specified amount are clamped. Limit current to maximum current ratings.
- θ_{JA} is measured in free air with the component mounted on a high effective thermal conductivity test board with "direct attach" features. See Tech Brief [TB379](#).
- For θ_{JC} , the "case temp" location is the center of the exposed metal pad on the package underside.

Electrical Specifications - 2.7V to 3.6V Supply Test Conditions: VDD = +3.0V, GND = 0V, VCTRL = 1.4V, VIN = 0.5V, (Notes 9, 10), Unless Otherwise Specified. **Boldface limits apply over the operating temperature range, -40°C to +85°C.**

PARAMETER	TEST CONDITIONS	TEMP (°C)	MIN (Notes 10, 11)	TYP	MAX (Notes 10, 11)	UNITS
ANALOG SWITCH CHARACTERISTICS						
Analog Input Signal Range, VANALOG	VDD = 3.3V	Full	-1.5	-	1.5	V
ON-Resistance, rON	IXOUT = 40mA, VLIN or VRIN = -0.85V to 0.85V, (See Figure 2, Note 14)	+25	-	2.5	2.8	Ω
		Full	-	-	3.8	Ω
rON Flatness, rFLAT(ON)	IXOUT = 40mA, VLIN or VRIN = -0.85V to 0.85V, (Notes 12, 14)	+25	-	20	60	m Ω
		Full	-	-	70	m Ω
rON Matching Between Channels, Δr_{ON}	IXOUT = 40mA, VLIN or VRIN = Voltage at max rON over signal range of -0.85V to 0.85V, (Notes 13, 14)	+25	-	0.1	0.32	Ω
		Full	-	-	0.4	Ω
Active Click and Pop Shunt Resistance	VCTRL = 0V, VIN = 0V, VLIN or VRIN = -1.5V to 1.5V, ISL54410 only	+25	-	40	-	Ω
		Full	-	-	-	Ω
DYNAMIC CHARACTERISTICS						
Turn-ON Time, tON	VDD = 2.7V, RL = 50 Ω , CL = 10pF (see Figure 1)	+25	-	5	-	μ s
Turn-OFF Time, tOFF	VDD = 2.7V, RL = 50 Ω , CL = 10pF (see Figure 1)	+25	-	45	-	ns
OFF-Isolation	VIN = 3V, VLIN or VRIN = 0.707VRMS, RL = 32 Ω , f = 20Hz to 20kHz (see Figure 3)	+25	-	110	-	dB
Crosstalk RIN to LOU, LIN to ROU	VCTRL = 3.0V, VIN = 0V, RL = 32 Ω , f = 20Hz to 20kHz, VLIN or VRIN = 0.707VRMS (2Vp-p), (See Figure 4)	+25	-	-90	-	dB

ISL54409, ISL54410

Electrical Specifications - 2.7V to 3.6V Supply Test Conditions: $V_{DD} = +3.0V$, $GND = 0V$, $V_{CTRL} = 1.4V$, $V_{IN} = 0.5V$, (Notes 9, 10), Unless Otherwise Specified. **Boldface limits apply over the operating temperature range, -40°C to +85°C . (Continued)**

PARAMETER	TEST CONDITIONS	TEMP (°C)	MIN (Notes 10, 11)	TYP	MAX (Notes 10, 11)	UNITS
Total Harmonic Distortion	$f = 20\text{Hz to } 20\text{kHz}$, $V_{CTRL} = 3.0V$, $V_{IN} = 0V$, V_{LIN} or $V_{RIN} = 0.36V_{RMS}$ (1V _{P-P}), $R_L = 32\Omega$	+25	-	0.03	-	%
	$f = 20\text{Hz to } 20\text{kHz}$, $V_{CTRL} = 3.0V$, $V_{IN} = 0V$, V_{LIN} or $V_{RIN} = 0.707V_{RMS}$ (2V _{P-P}), $R_L = 32\Omega$	+25	-	0.06	-	%
COM-, COM+ OFF Capacitance, C_{OFF}	$f = 240\text{MHz}$, $V_{CTRL} = 0V$, $V_{IN} = 3V$, V_{LIN} or $V_{RIN} = 0V$	+25	-	5	-	pF
	$f = 240\text{MHz}$, $V_{CTRL} = 0V$, $V_{IN} = 0V$, V_{LIN} or $V_{RIN} = 0V$	+25	-	4	-	pF
POWER SUPPLY CHARACTERISTICS						
Power Supply Range, V_{DD}		Full	2.7		3.6	V
Audio Mode Supply Current, I_{DD}	$V_{DD} = 3.6V$	+25	-	7	13	μA
		Full	-	-	15	μA
Shutdown Current, I_{SHDN}	$V_{DD} = 3.6V$, $V_{CTRL} = 0.5V$, $V_{IN} = 0.5V$; ISL54409	+25	-	1	10	nA
		Full	-	-	150	nA
	$V_{DD} = 3.6V$, $V_{CTRL} = 0.5V$, $V_{IN} = 0.5V$; ISL54410	+25	-	2.4	4	μA
		Full	-	-	5	μA
Power OFF-Current, $I_{RIN/LIN}$ or $I_{COM-/COM+}$	$V_{DD} = 0V$, $V_{CTRL} = V_{IN} = \text{Float}$, $V_{LIN/RIN} = V_{COM-/COM+} = 5.25V$,	+25	-	7	-	μA
DIGITAL INPUT CHARACTERISTICS						
Logic Voltage Low, V_{Logic_L}	$V_{DD} = 2.7V$ to $3.6V$	Full	-	-	0.5	V
Logic Voltage High, V_{Logic_H}	$V_{DD} = 2.7V$ to $3.6V$	Full	1.4	-	-	V
Logic Input Low Current, I_{Logic_L}	$V_{DD} = 3.6V$, $V_{Logic} = 0V$	Full	-50	20	50	nA
Logic Input High Current, I_{Logic_H}	$V_{DD} = 3.6V$, $V_{Logic} = 3.6V$	Full	-2	1	2	μA
Logic Pull-Down Resistor, R_{Logic}	$V_{DD} = 3.6V$, $V_{Logic} = 3.6V$	Full	-	4	-	M Ω

NOTES:

9. V_{Logic} = Logic input voltage to perform proper function.
10. The algebraic convention, whereby the most negative value is a minimum and the most positive a maximum, is used in this data sheet.
11. Parameters with MIN and/or MAX limits are 100% tested at +25°C, unless otherwise specified. Temperature limits established by characterization and are not production tested.
12. Flatness is defined as the difference between maximum and minimum value of ON-resistance over the specified analog signal range.
13. r_{ON} matching between channels is calculated by subtracting the channel with the highest max r_{ON} value from the channel with lowest max r_{ON} value.
14. Limits established by characterization and are not production tested.

Test Circuits and Waveforms

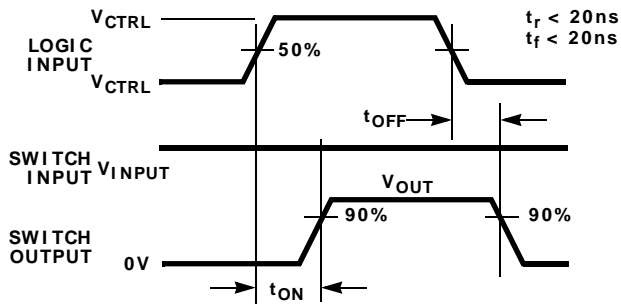
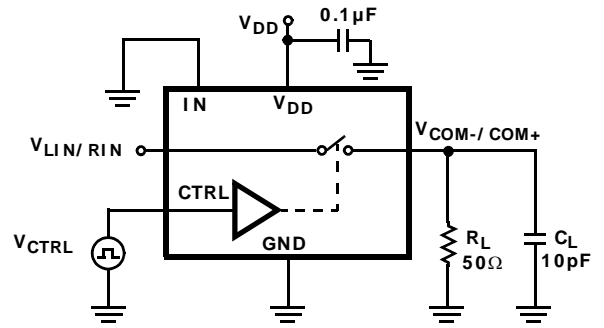

FIGURE 1A. MEASUREMENT POINTS

FIGURE 1. SWITCHING TIMES



* C_L includes board capacitance

FIGURE 1B. TEST CIRCUIT

Repeat test for all switches.
 $r_{ON} = V_1 / 40mA$

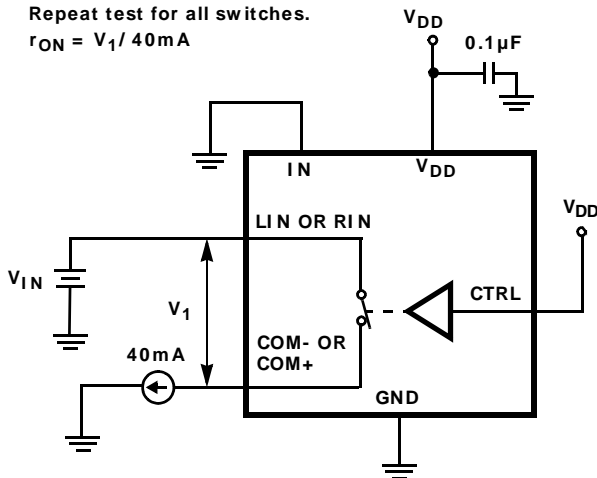

FIGURE 2. r_{ON} TEST CIRCUIT

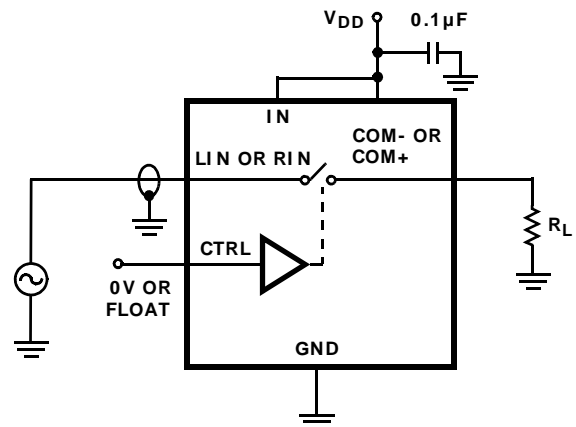

FIGURE 3. OFF ISOLATION CIRCUIT

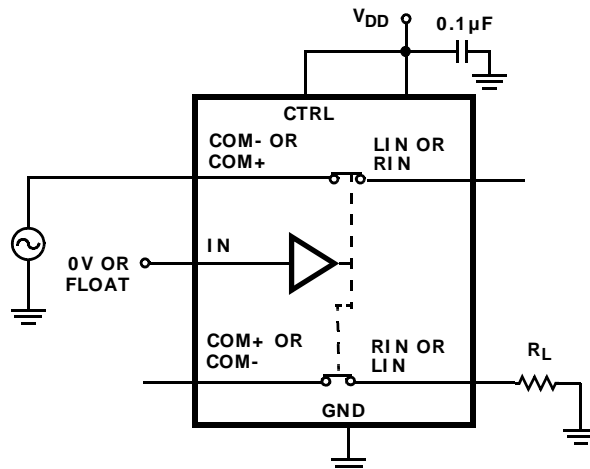

FIGURE 4. CROSSTALK TEST CIRCUIT

Detailed Description

The ISL54409, ISL54410 are +2.7 to +5.0V, Single Pole Single Throw (SPST) audio switches that are negative swing capable. The switch outputs (COM-, COM+) have low OFF capacitance (4pF) that is capable of multiplexing USB2.0 HS data and audio signals in a wired-OR configuration for common connector applications (see “Application Block Diagrams” on page 2). The ISL54409 features a low power shutdown mode while the ISL54410 features audio Click and Pop Elimination circuitry.

The ISL54409, ISL54410 are offered in a 8 Ld 2mmx2mm TDFN or 10 Ld 1.4x1.8mm μ TQFN packages.

Power Supply Considerations

The ISL54409, ISL54410 operates on a +2.7V to +5.0V power supply. A 0.1 μ F local decoupling capacitor placed as close as possible from the V_{DD} pin to GND is highly recommended for stable operation.

Audio Switches

The ISL54409, ISL54410 switches are designed to have low THD+N from a signal range of -1V to +1V for audio applications (see Figures 8 through 11). The ON-resistance of the audio switches have a typical resistance of 2.6 Ω

The analog signal range of the audio switches are capable beyond -1V to +1V however, the ON-resistance of the switches increases beyond it. The THD+N performance deteriorates beyond a signal range of -1V to +1V.

Audio/ USB wired-OR Application

The ISL54409, ISL54410 allows the connection of an audio codec and USB Controller to a common connector. For audio mode of operation, the switch is closed to pass low distortion audio from the codec to a headphone. When the switch is open, USB2.0 HS data (480Mbps) can be transmitted to a host controller with minimal signal degradation.

Since the USB device is always connected to the COM- and COM+ pins on the ISL54409, ISL54410, considerations must be taken to protect the USB Controller when passing audio signals through the switch. The USB2.0 specification requires the USB data line to sustain a signal of -1V without damage to the device. Audio signals from the codec may swing below -1V in some applications. Since the USB Controller is high impedance when not operating, exceeding -1V may cause high leakage currents or damage sensitive devices on the USB device. It is highly recommended to keep the audio signal range within -1V to +1V.

USB V_{BUS} Hot Plug Operation

The ISL54409, ISL54410 allows the hot plug operation of the USB V_{BUS} signal to operate the switch. This can be accomplished by connecting CTRL to V_{DD} at all times. The V_{BUS} signal from the USB Host is used to drive the IN logic pin. Note from the “Absolute Maximum Ratings” on page 5 that the IN pin must be kept below V_{DD} .

Exceeding V_{DD} by putting the 5V V_{BUS} signal to the IN pin will forward bias the ESD diode on the IN pin, which will draw excessive diode current and result in a damaged pin on the device. To prevent damage to the IN pin, it is recommended to place a current limiting series resistor or use a voltage divider to bring the voltage at the IN pin below V_{DD} . A 10k Ω series resistor will reduce current significantly to prevent possible damage to the IN pin. For further protection, a voltage divider with $R_T = 10k\Omega$ will reduce the IN voltage below V_{DD} with no impact on logic threshold voltages (see Figure 5).

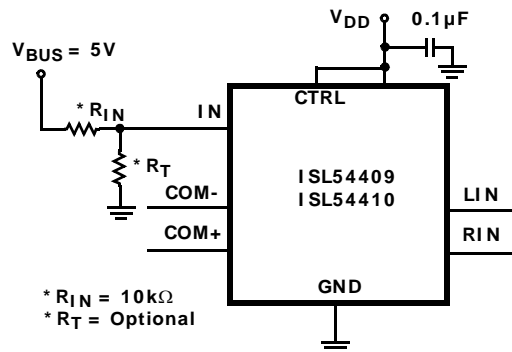

FIGURE 5. USB V_{BUS} HOT PLUG PROTECTION

Low Power Shutdown/ Click and Pop Mode

When the CTRL and IN pins are at logic “0”, the ISL54409 and ISL54410 enter into a disabled mode of operation. In the disabled mode of operation, both switches are turned OFF. For the ISL54409, the disabled mode is Low Power Shutdown. The device is brought to a low powered state and the I_{CC} current is significantly reduced.

* Note: When placed in the Low Power Shutdown state, the internal charge pumps that generate the negative supply rails for negative signal swing capability are turned off to reduce power consumption. With the internal negative supply rail disabled the ISL54409 will have poor isolation and crosstalk performance for negative signal swings on the switch terminals. Negative voltages will have a low impedance path to the other switch terminals. It is not recommended to operate the switch in Low Power Shutdown if the audio codec will remain active when transmitting USB data on the COM- and COM+ pins.

For the ISL54410, the disabled mode is Audio Click and Pop Elimination. The switch input pins LIN and RIN have their active Click and Pop circuitry enabled, which turns on a typical 40 Ω shunt resistance from the switch input pin to GND. Some audio application requires DC biasing the audio codec above ground for full output signal swing. The audio signal must have the DC component removed with a blocking capacitor at the headphone load. This blocking capacitor is typically the source of audible click and pop transients when the audio codec powers up or down with the DC bias. The negative signal swing capability of the audio switch allows the DC blocking capacitor to be placed on input side of the switch, which allows the Click and Pop Elimination circuitry to discharge the DC blocking capacitor of any transient currents, eliminating audio clicks and pops.

Typical Performance Curves $T_A = +25^\circ\text{C}$, Unless Otherwise Specified

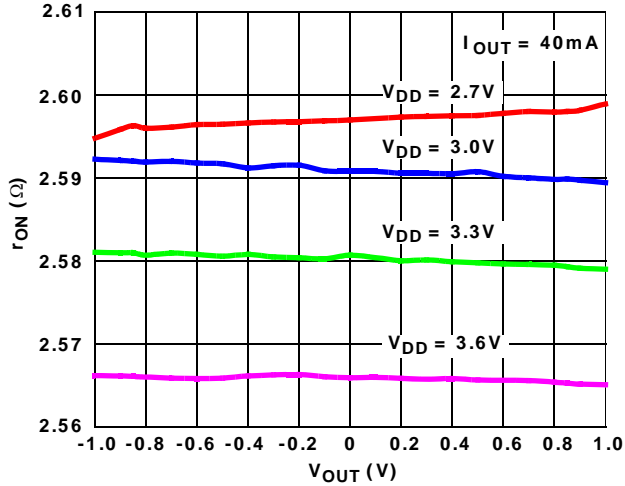

FIGURE 6. ON-RESISTANCE vs SWITCH VOLTAGE vs SUPPLY VOLTAGE

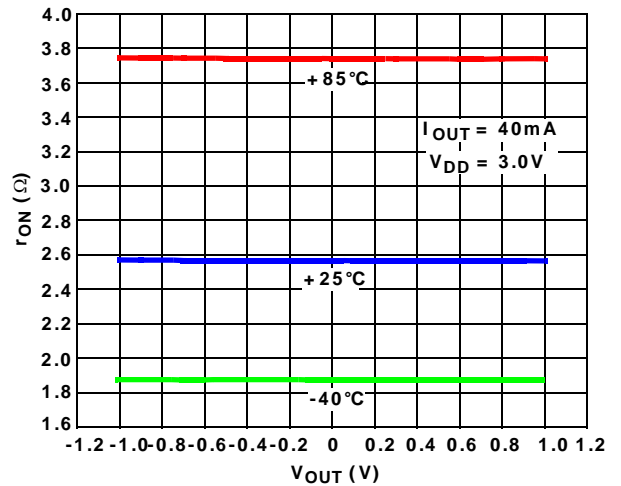

FIGURE 7. ON-RESISTANCE vs SWITCH VOLTAGE vs TEMPERATURE

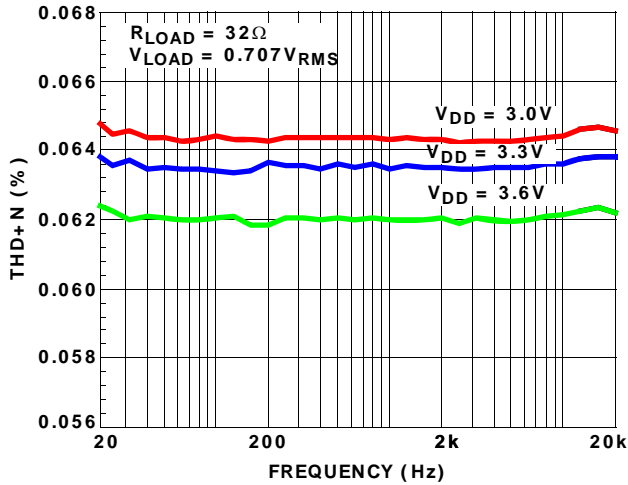

FIGURE 8. THD+N vs SUPPLY VOLTAGE vs FREQUENCY

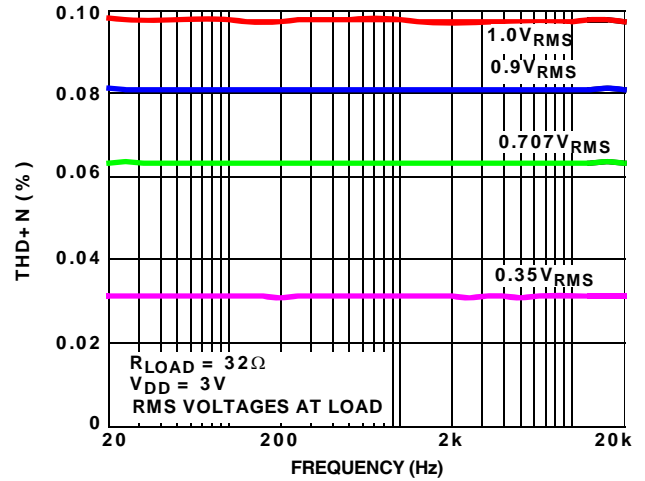

FIGURE 9. THD+N vs SIGNAL LEVELS vs FREQUENCY

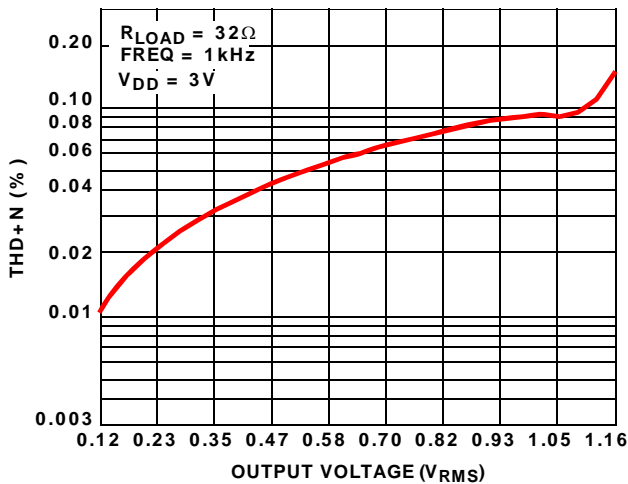

FIGURE 10. THD+N vs OUTPUT VOLTAGE

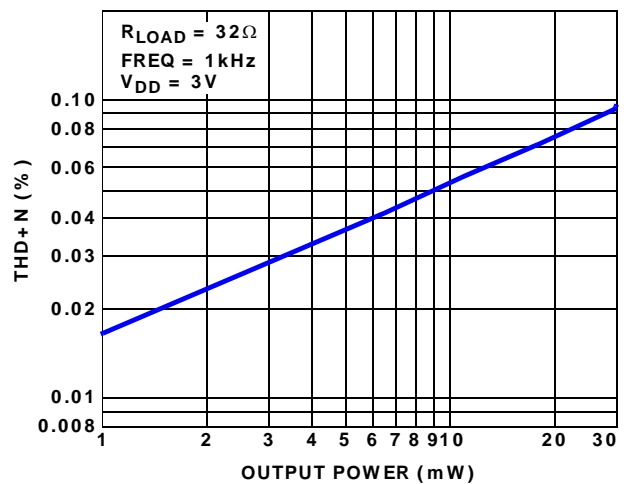

FIGURE 11. THD+N vs OUTPUT POWER

Typical Performance Curves $T_A = +25^\circ\text{C}$, Unless Otherwise Specified (Continued)

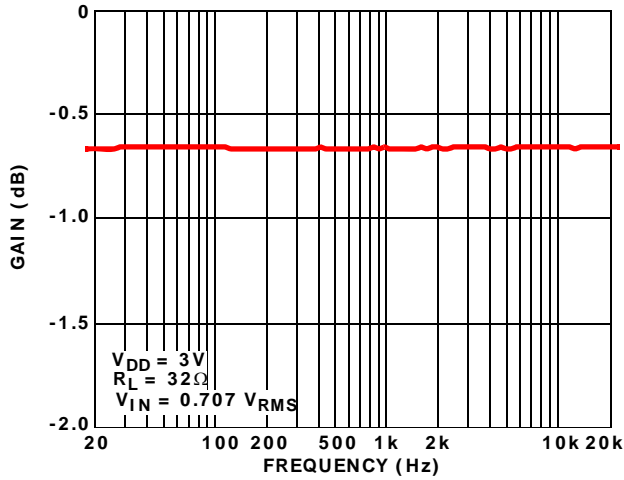

FIGURE 12. INSERTION LOSS

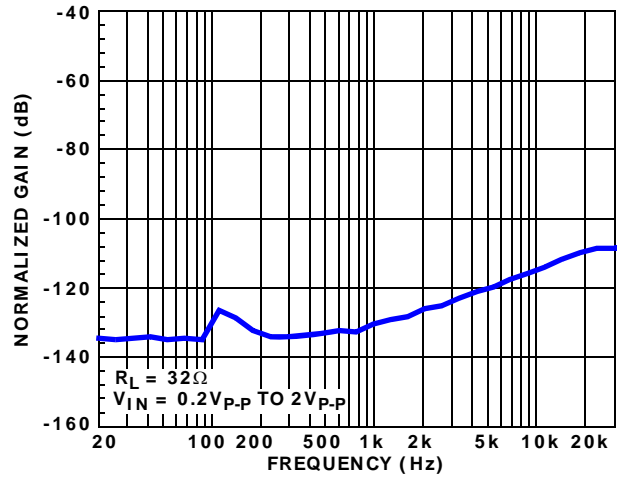

FIGURE 13. OFF-ISOLATION

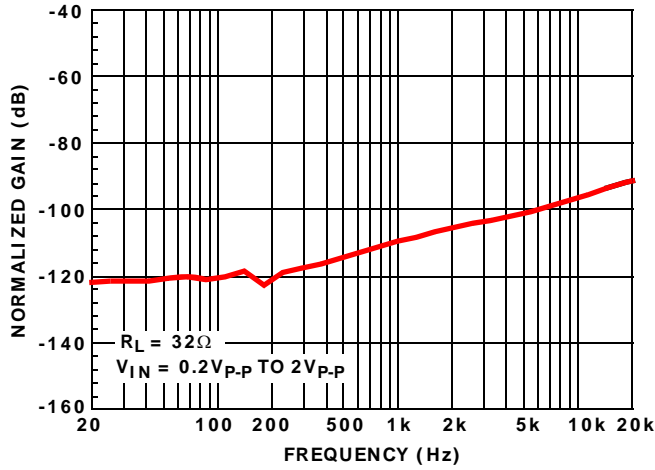

FIGURE 14. CROSSTALK

Revision History

The revision history provided is for informational purposes only and is believed to be accurate, but not warranted. Please go to web to make sure you have the latest Rev.

DATE	REVISION	CHANGE
1/14/10	FN6983.0	Removed "Coming Soon" from TDFN package options in "Ordering Information" on page 4. Added "ISL54409EVAL1Z" to "Ordering Information" on page 4. Updated Package Outline Drawing L10.1.8x1.4A on page 12. Revisions were to move dimensions from table onto drawing.
9/25/09	FN6983.0	Initial Release.

Products

Intersil Corporation is a leader in the design and manufacture of high-performance analog semiconductors. The Company's products address some of the industry's fastest growing markets, such as, flat panel displays, cell phones, handheld products, and notebooks. Intersil's product families address power management and analog signal processing functions. Go to www.intersil.com/products for a complete list of Intersil product families.

* For a complete listing of Applications, Related Documentation and Related Parts, please see the respective device information page on intersil.com: [ISL54409](http://www.intersil.com/ISL54409), [ISL54410](http://www.intersil.com/ISL54410)

To report errors or suggestions for this datasheet, please go to www.intersil.com/askourstaff

FITs are available from our website at <http://rel.intersil.com/reports/search.php>

For additional products, see www.intersil.com/product_tree

Intersil products are manufactured, assembled and tested utilizing ISO9000 quality systems as noted in the quality certifications found at www.intersil.com/design/quality

Intersil products are sold by description only. Intersil Corporation reserves the right to make changes in circuit design, software and/or specifications at any time without notice. Accordingly, the reader is cautioned to verify that data sheets are current before placing orders. Information furnished by Intersil is believed to be accurate and reliable. However, no responsibility is assumed by Intersil or its subsidiaries for its use; nor for any infringements of patents or other rights of third parties which may result from its use. No license is granted by implication or otherwise under any patent or patent rights of Intersil or its subsidiaries.

For information regarding Intersil Corporation and its products, see www.intersil.com

Package Outline Drawing

L10.1.8x1.4A

10 LEAD ULTRA THIN QUAD FLAT NO-LEAD PLASTIC PACKAGE

Rev 4, 9/09

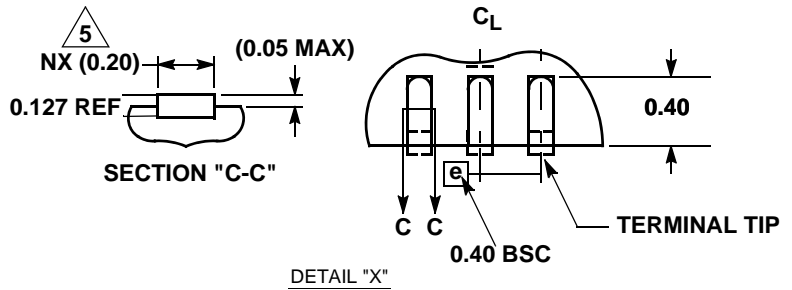
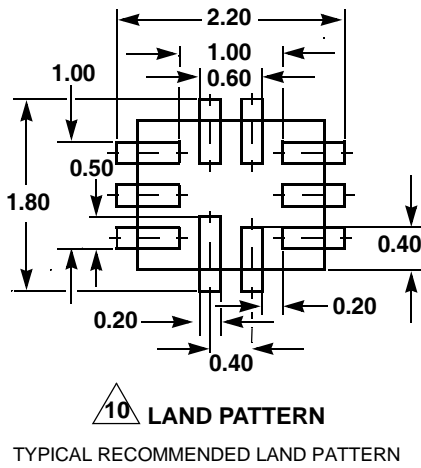
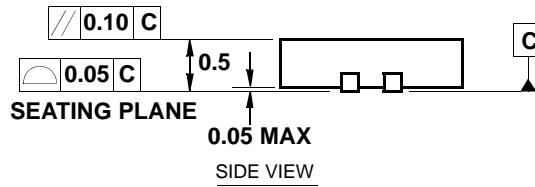
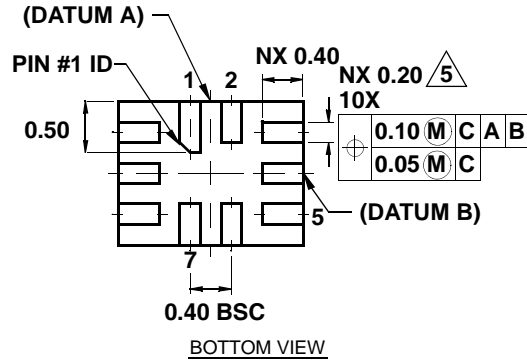
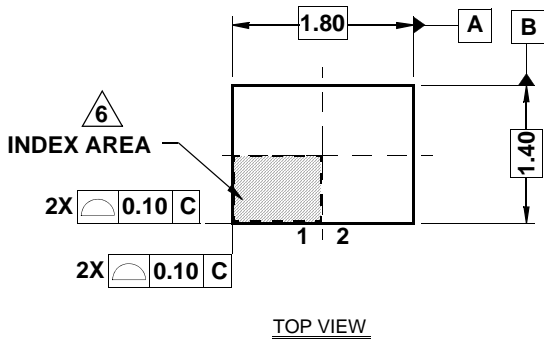

NOTES:

1. Dimensioning and tolerancing conform to ASME Y14.5-1994.
2. N is the number of terminals. Total 10 leads.
3. Nd and Ne refer to the number of terminals on D (4) and E (6) side, respectively.
4. All dimensions are in millimeters. Tolerances $\pm 0.05\text{mm}$ unless otherwise noted. Angles are in degrees.
5. Dimension b applies to the metallized terminal and is measured between 0.15mm and 0.30mm from the terminal tip.
6. The configuration of the pin #1 identifier is optional, but must be located within the zone indicated. The pin #1 identifier may be either a mold or mark feature.
7. Maximum package warpage is 0.05mm.
8. Maximum allowable burrs is 0.076mm in all directions.
9. JEDEC Reference MO-255.
10. For additional information, to assist with the PCB Land Pattern Design effort, see Intersil Technical Brief TB389.

Package Outline Drawing

L8.2x2C

8 LEAD THIN DUAL FLAT NO-LEAD PLASTIC PACKAGE (TDFN) WITH E-PAD

Rev 0, 07/08

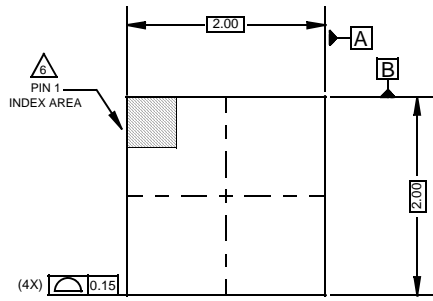

TOP VIEW

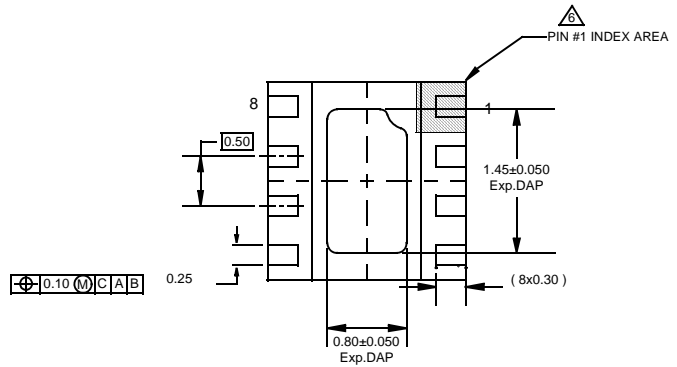

BOTTOM VIEW

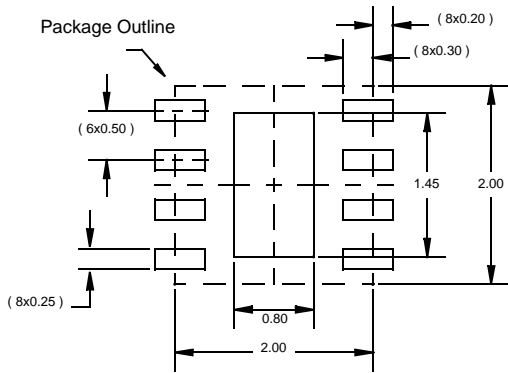

TYPICAL RECOMMENDED LAND PATTERN

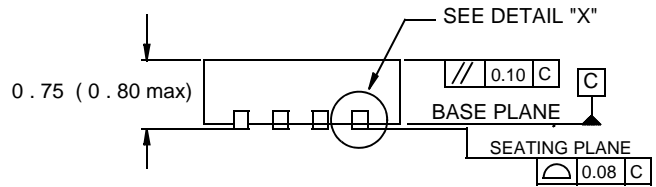

SIDE VIEW

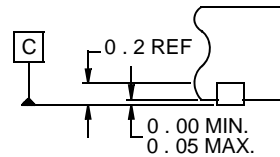

DETAIL "X"

NOTES:

1. Dimensions are in millimeters.
Dimensions in () for Reference Only.
2. Dimensioning and tolerancing conform to AMSE Y14.5m-1994.
3. Unless otherwise specified, tolerance : Decimal ± 0.05
4. Dimension b applies to the metallized terminal and is measured between 0.15mm and 0.30mm from the terminal tip.
5. Tiebar shown (if present) is a non-functional feature.
6. The configuration of the pin #1 identifier is optional, but must be located within the zone indicated. The pin #1 identifier may be either a mold or mark feature.