

4 TERMINAL 3A OUTPUT LOW DROP VOLTAGE REGULATOR

The KIA378R × × Series are Low Drop Voltage Regulator suitable for various electronic equipments.

It provides constant voltage power source with TO-220IS-4 terminal lead full molded PKG. The Regulator has multi-function such as over current protection, overheat protection and ON/OFF control.

FEATURES

- 3.0A Output Low Drop Voltage Regulator.
- Built in ON/OFF Control Terminal.
- Built in Over Current Protection, Over Heat Protection Function.

LINE UP

ITEM	OUTPUT VOLTAGE (Typ.)	UNIT
KIA378R25PI	2.5	V
KIA378R33PI	3.3	
KIA378R35PI	3.5	

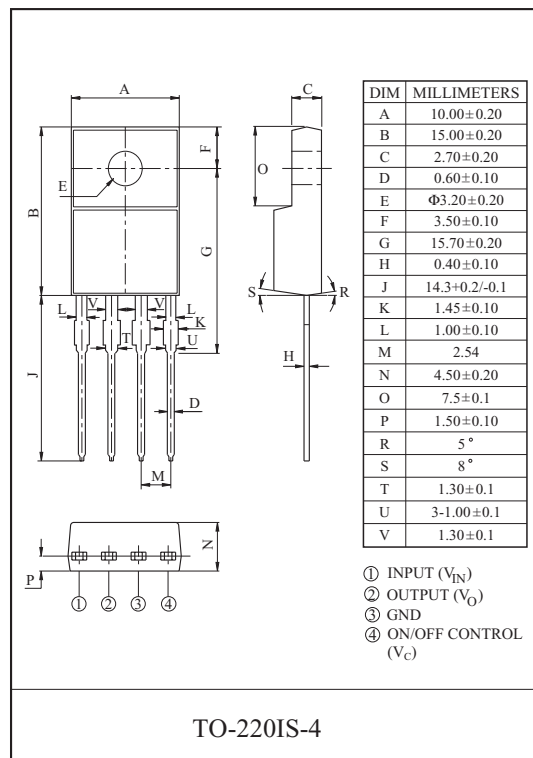

MAXIMUM RATINGS ($T_a=25\text{ }^\circ\text{C}$)

CHARACTERISTIC	SYMBOL	RATING	UNIT	Remark
Input Voltage	V_{IN}	35	V	-
ON/OFF Control Voltage	V_C	35	V	-
Output Current	I_O	3	A	-
Power Dissipation 1	P_{d1}	1.5	W	No heatsink
Power Dissipation 2	P_{d2}	15	W	with heatsink
Operating Junction Temperature	$T_{J(opr)}$	-40~150	$^\circ\text{C}$	-
Storage Temperature	T_{stg}	-45 ~150	$^\circ\text{C}$	-
Soldering Temperature (10sec)	T_{sol}	260	$^\circ\text{C}$	-

KIA378R25PI~KIA378R35PI

ELECTRICAL CHARACTERISTICS

(Unless otherwise specified, $I_O=1.0A$, $T_a=25^\circ C$, Note1.)

CHARACTERISTIC		SYMBOL	CONDITIONS	MIN.	TYP.	MAX.	UNIT
Output Voltage	KIA378R25	V_O	-	2.438	2.50	2.562	V
	KIA378R33		-	3.220	3.30	3.380	
	KIA378R35		-	3.413	3.50	3.587	
Load Regulation		Reg Load	$I_O=5mA \sim 3A$	-	0.1	2.0	%
Line Regulation		Reg Line	(Note 2)	-	0.5	2.5	%
Temperature Coefficient of Output Voltage		$T_C V_O$	$T_j=0 \sim 125^\circ C$	-	± 0.02	± 0.05	%/ $^\circ C$
Ripple Rejection		$R \cdot R$	-	45	55	-	dB
Drop Out Voltage		V_D	$I_O=3A$	-	-	0.5	V
Output ON state for control Voltage		$V_{C(ON)}$	-	2.0	-	-	V
Output ON state for control Current		$I_{C(ON)}$	$V_C=2.7V$	-	-	20	μA
Output OFF state for control Voltage		$V_{C(OFF)}$	-	-	-	0.8	V
Output OFF state for control Current		$I_{C(OFF)}$	$V_C=0.4V$	-	-	-0.4	mA
Quiescent Current		I_Q	$I_O=0$	-	-	10	mA

Note1) V_{IN} of KIA378R25=4.2V

" KIA378R33=5.0V

" KIA378R35=5.2V

Note2) V_{IN} of KIA378R25=3.2 ~10V

" KIA378R33=4.0 ~10V

" KIA378R35=4.2 ~10V

Note3) At $V_{IN}=0.95V_{out}$

BLOCK DIAGRAM

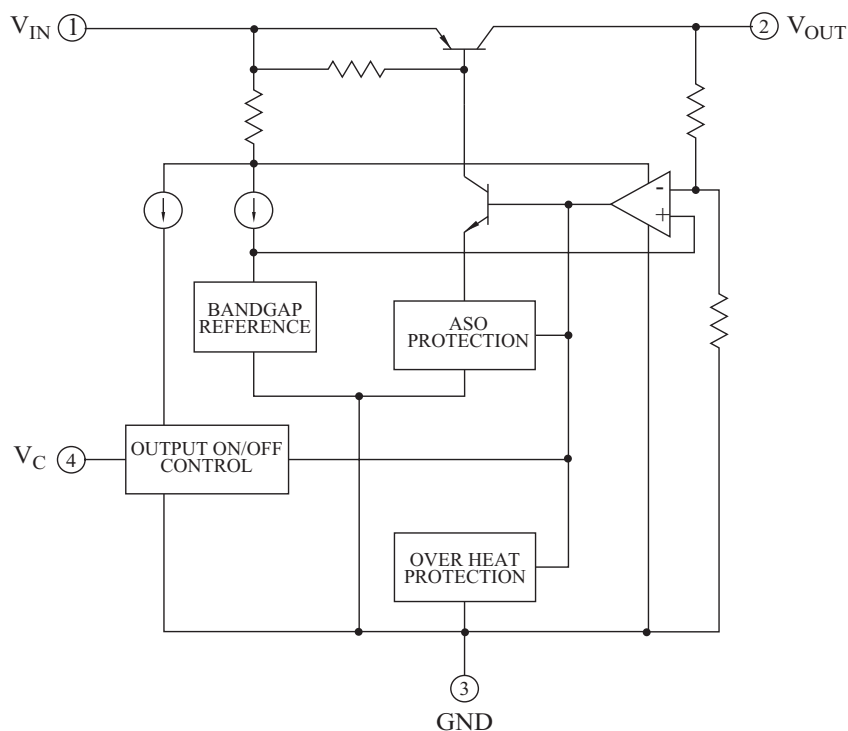

KIA378R25PI~KIA378R35PI

Fig. 1 Standard Test Circuit

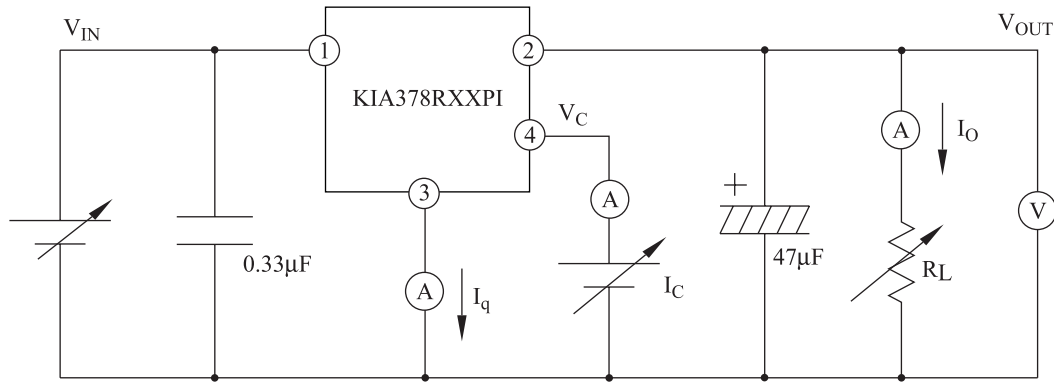

Fig. 1-2 Ripple Rejection Test Circuit

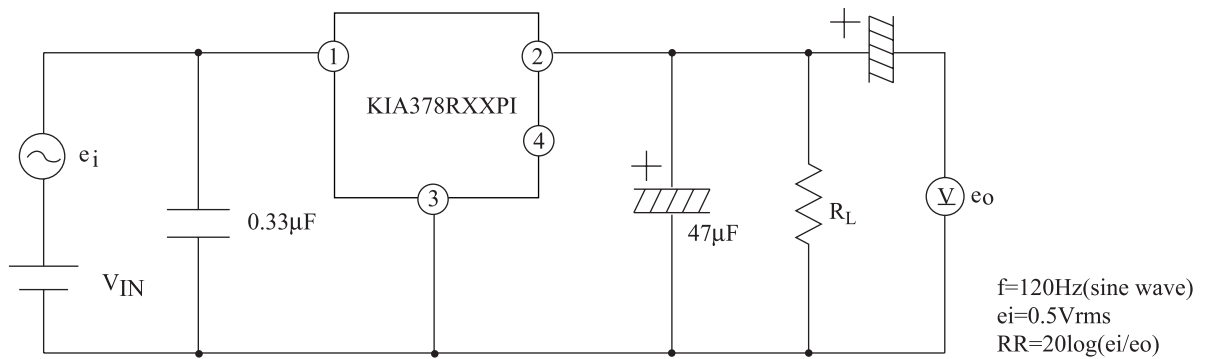
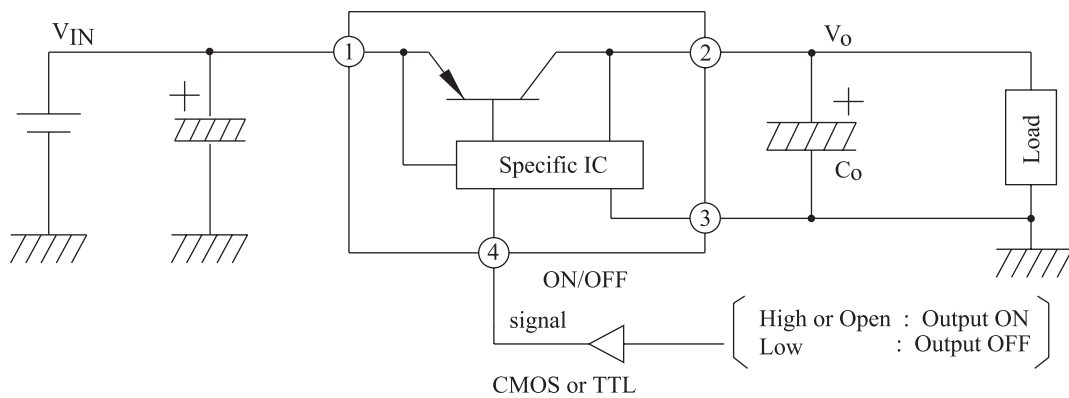
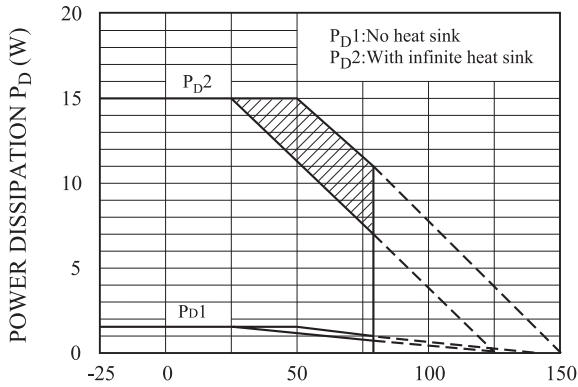

Fig. 2 Application Circuit for Standard



KIA378R25PI~KIA378R35PI

Fig.3 $T_a - P_D$



AMBIENT TEMPERATURE T_a (°C)
 Note) Oblique line portion : Overheat protection may operate in this area.

Fig.4 $I_O - V_O$

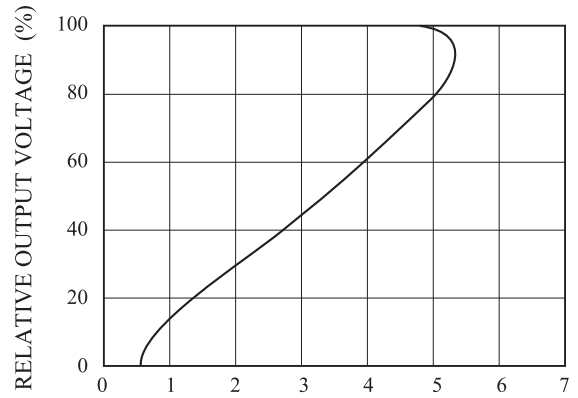

OUTPUT CURRENT I_O (A)

Fig.5-1 $T_j - \Delta V_O$ (KIA378R25)

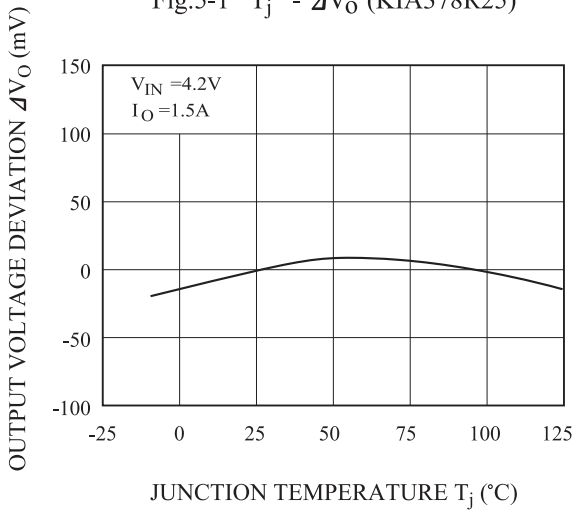

JUNCTION TEMPERATURE T_j (°C)

Fig.5-3 $T_j - \Delta V_O$ (KIA378R33)

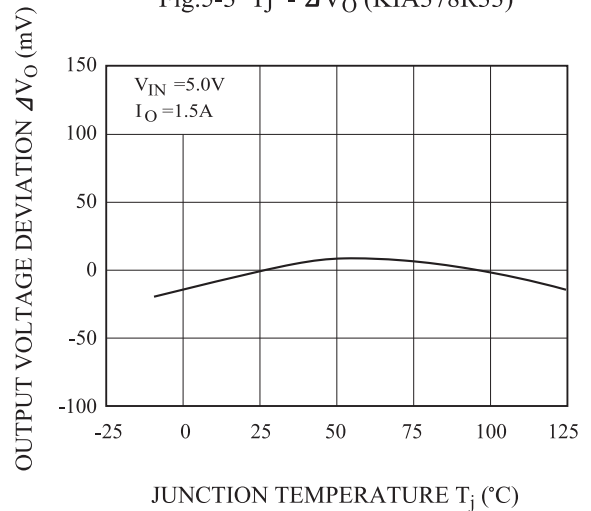

JUNCTION TEMPERATURE T_j (°C)

Fig.5-4 $T_j - \Delta V_O$ (KIA378R35)

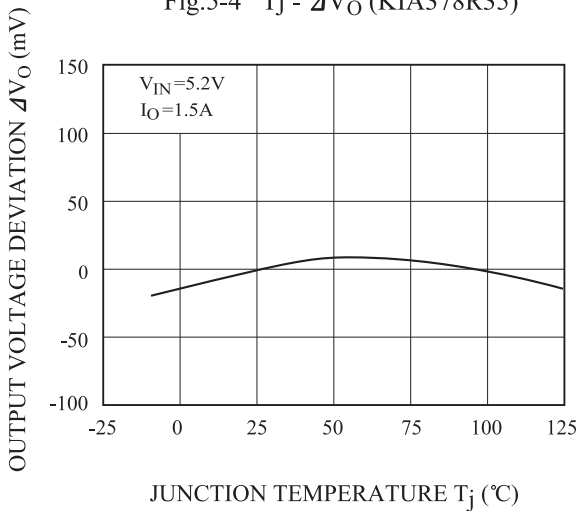

JUNCTION TEMPERATURE T_j (°C)

Fig.6 $T_j - V_D$

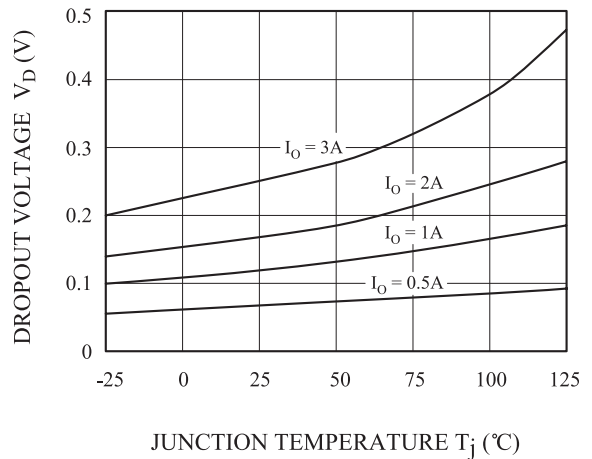

JUNCTION TEMPERATURE T_j (°C)

KIA378R25PI~KIA378R35PI

Fig.7 $T_j - I_q$

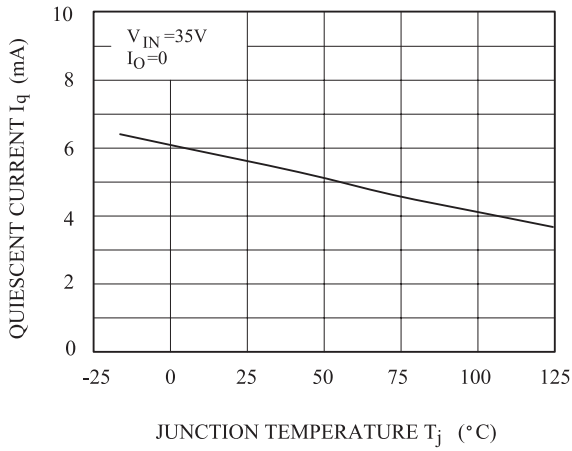

Fig.8-1 $f - RR$

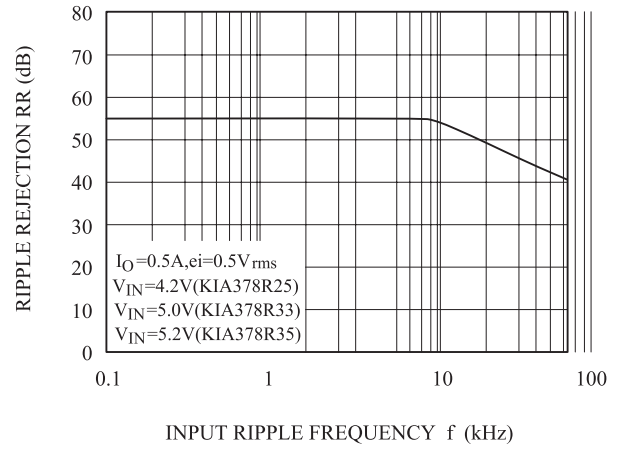

Fig.8-2 $I_O - RR$

