

Triple Inverter

FEATURES

- High output drive : $\pm 24\text{mA}(\text{min.}) @ V_{CC}=3\text{V}$.
- Super high speed operation : $t_{pd} 2.3\text{ns}(\text{typ.}) @ V_{CC}=5\text{V}, 50\text{pF}$.
- Operation voltage range : $V_{CC(\text{opr})}=1.65\sim 5.5\text{V}$.
- Latch-up performance : $\pm 500\text{mA}$ or more
- ESD performance : $\pm 200\text{V}$ or more (EIAJ)
 $\pm 2000\text{V}$ or more (MIL)

MARKING

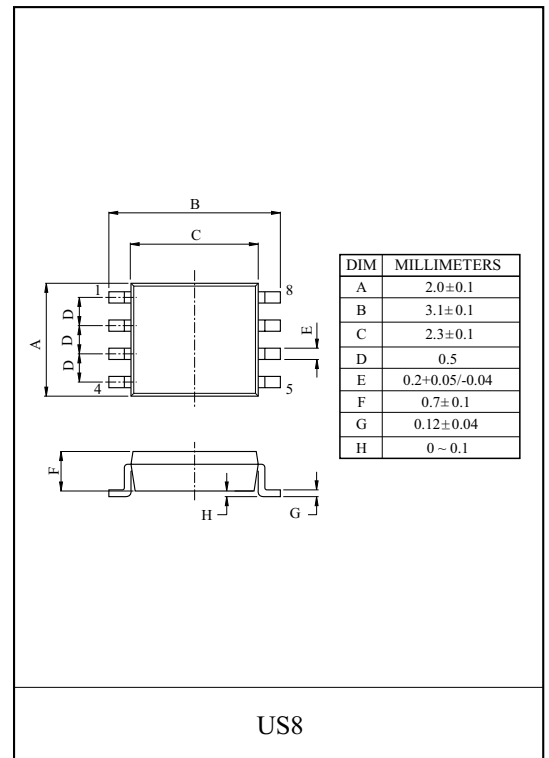
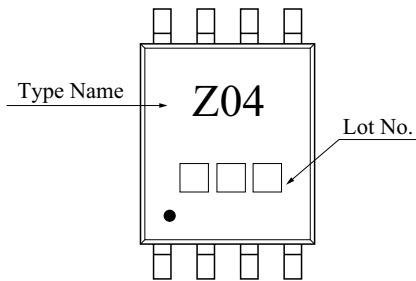

MAXIMUM RATINGS (Ta=25 °C)

CHARACTERISTIC	SYMBOL	RATING	UNIT
Power Supply Voltage	V_{CC}	-0.5~6	V
DC Input Voltage	V_{IN}	-0.5~6	V
DC Output Voltage	V_{OUT}	-0.5~6	V
Input Diode Current	I_{IK}	-20	mA
Output Diode Current	I_{OK}	-20	mA
DC Output Current	I_{OUT}	± 50	mA
DC V_{CC} /ground Current	I_{CC}	± 50	mA
Power Dissipation	P_D	200	mW
Storage Temperature Range	T_{stg}	-65 ~ 150	°C
Lead Temperature (10s)	T_L	260	°C

PIN CONNECTION(TOP VIEW)

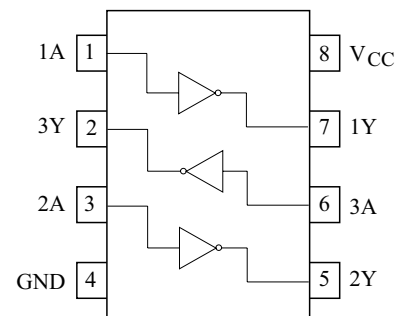

KIC7WZ04FK

Truth Table

A	Y
L	H
H	L

Logic Diagram



Recommended Operating Conditions

CHARACTERISTIC	SYMBOL	RATING	UNIT
Supply Voltage	V_{CC}	1.65~5.5	V
		1.5~5.5 (Note1)	
Input Voltage	V_{IN}	0~5.5	V
Output Voltage	V_{OUT}	0~5.5 (Note2)	V
		0~ V_{CC} (Note3)	
Operating Temperature	T_{opr}	-40~85	°C
Input Rise and Fall Time	d_i/d_v	0~20 ($V_{CC}=1.8V \pm 0.15V,$ 2.5V $\pm 0.2V$)	ns/V
		0~10 ($V_{CC}=3.3V \pm 0.3V$)	
		0~5 ($V_{CC}=5.5V \pm 0.5V$)	

Note1 : Data retention only.

Note2 : $V_{CC}=0V$.

Note3 : High or low state

KIC7WZ04FK

ELECTRICAL CHARACTERISTICS

DC Characteristics

CHARACTERISTIC		SYMBOL	TEST CONDITION		Ta=25 °C			Ta=-40~85 °C		UNIT	
					V _{CC} (V)	MIN.	TYP.	MAX.	MIN.		MAX.
Input Voltage	High Level	V _{IH}	-	1.65~1.95	0.75 × V _{CC}	-	-	0.75 × V _{CC}	-	V	
				2.3~5.5	0.7 × V _{CC}	-	-	0.7 × V _{CC}	-		
	Low Level	V _{IL}	-	1.65~1.95	-	-	0.25 × V _{CC}	-	0.25 × V _{CC}		
				2.3~5.5	-	-	0.3 × V _{CC}	-	0.3 × V _{CC}		
Output Voltage	High Level	V _{OH}	V _{IN} =V _{IL}	I _{OH} =-100 μA	1.65	1.55	1.65	-	1.55	-	V
					2.3	2.2	2.3	-	2.2	-	
					3.0	2.9	3.0	-	2.9	-	
					4.5	4.4	4.5	-	4.4	-	
				I _{OH} =-4mA	1.65	1.29	1.52	-	1.29	-	
					2.3	1.9	2.15	-	1.9	-	
					3.0	2.4	2.8	-	2.4	-	
					4.5	3.8	4.2	-	3.8	-	
	Low Level	V _{OL}	V _{IN} =V _{IH}	I _{OL} =100 μA	1.65	-	0	0.1	-	0.1	
					2.3	-	0	0.1	-	0.1	
					3.0	-	0	0.1	-	0.1	
					4.5	-	0	0.1	-	0.1	
				I _{OL} =4mA	1.65	-	0.08	0.24	-	0.24	
					2.3	-	0.1	0.3	-	0.3	
					3.0	-	0.15	0.4	-	0.4	
					4.5	-	0.22	0.55	-	0.55	
I _{OL} =8mA	2.3	-	0.1	0.3	-	0.3					
	3.0	-	0.15	0.4	-	0.4					
I _{OL} =16mA	3.0	-	0.15	0.4	-	0.4					
	4.5	-	0.22	0.55	-	0.55					
I _{OL} =24mA	3.0	-	0.22	0.55	-	0.55					
	4.5	-	0.22	0.55	-	0.55					
Input Leakage Current		I _{IN}	V _{IN} =5.5V or GND	0~5.5	-	-	±1	-	±10	μA	
Quiescent Supply Current		I _{CC}	V _{IN} =5.5V or GND	1.65~5.5	-	-	1	-	10	μA	

AC Characteristics (unless otherwise specified, Input : t_r=t_f=3ns)

CHARACTERISTIC		SYMBOL	TEST CONDITION		Ta=25 °C			Ta=-40~85 °C		UNIT
					V _{CC} (V)	MIN.	TYP.	MAX.	MIN.	
Propagation delay time	t _{PLH} t _{PHL}	C _L =15pF, R _L =1M Ω	1.8 ± 0.15	1.8	4.4	9.5	2.0	10.0	ns	
			2.5 ± 0.2	1.2	3.0	5.1	1.2	5.6		
			3.3 ± 0.3	0.8	2.2	3.4	0.8	3.8		
			5.0 ± 0.5	0.5	1.8	2.8	0.5	3.1		
			C _L =50pF, R _L =500 Ω	3.3 ± 0.3	1.2	2.9	4.5	1.2	5.0	ns
				5.0 ± 0.5	0.8	2.3	3.6	0.8	4.0	
Input Capacitance		C _{IN}	-	0~5.5	-	3.0	-	-	-	pF
Power Dissipation Capacitance		C _{PD}	(Note)	3.3	-	18	-	-	-	pF
				5.5	-	23	-	-	-	

Note : C_{PD} is defined as the value of the internal equivalent capacitance which is calculated from the operating current consumption without load. Average operating current can be obtained by the equation : I_{CC(oper)}=C_{PD} · V_{CC} · f_{IN}+I_{CC}/3