

DATA SHEET

SKY13414-485LF: 0.1-3.0 GHz SP4T Antenna Switch

Applications

- Any 2G/3G/4G antenna diversity or LTE (TDD/FDD) transmit/receive system for which GSM transmit is not required

Features

- Broadband frequency range: 0.1 to 3.0 GHz
- Low insertion loss: 0.55 dB typical @ 2.7 GHz
- High isolation: >25 dB @ 2.7 GHz
- Internal 50 Ω port to control diversity antenna impedance when device is not in use
- Integrated logic
- Small QFN (14-pin, 2.0 x 2.0 mm) package (MSL1, 260 °C per JEDEC J-STD-020)



Skyworks Green™ products are compliant with all applicable legislation and are halogen-free. For additional information, refer to *Skyworks Definition of Green™*, document number SQ04-0074.

Description

The SKY13414-485LF is a Single Pole, Four-Throw (SP4T) antenna switch. With an internal 50 Ω termination. The high linearity performance and low insertion loss achieved by the SKY13414-485LF make it an ideal choice for main/diversity switching commonly used in LTE-based handsets, data cards, and tablets that use antenna diversity solutions.

The SKY13414-485LF is part of a scalable family of products that covers SP4T through SP8T switches that allow up to eight bands of WCDMA/LTE. The symmetric port designs provide flexibility in signal routing for both receive diversity and higher power TD-SCDMA/TDD-LTE, WCDMA/FDD, and LTE transmit/receive applications.

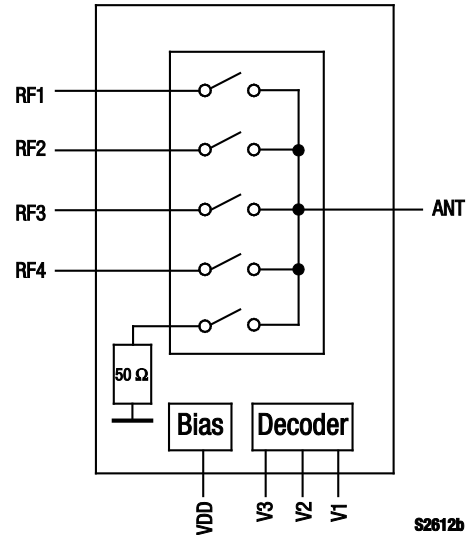

Figure 1. SKY13414-485LF Block Diagram

Switching is controlled by three CMOS/TTL-compatible control voltage inputs (V1, V2, and V3). Depending on the logic voltage level applied to the control pins, the ANT pin is connected to one of four switched RF outputs (RF1 to RF4) using a low insertion loss path, while the paths between the ANT pin and the other RF pins are in a high isolation state. The antenna path can also be closed on a 50 Ω load when it needs to be terminated. The 50 Ω load is internally grounded. No external blocking capacitors are required on the RF paths.

The SKY13414-485LF is manufactured in a compact, 14-pin 2.0 x 2.0 mm, Quad Flat No-Lead (QFN) package.

A functional block diagram is shown in Figure 1. The pin configuration and package are shown in Figure 2. Signal pin assignments and functional pin descriptions are provided in Table 1.

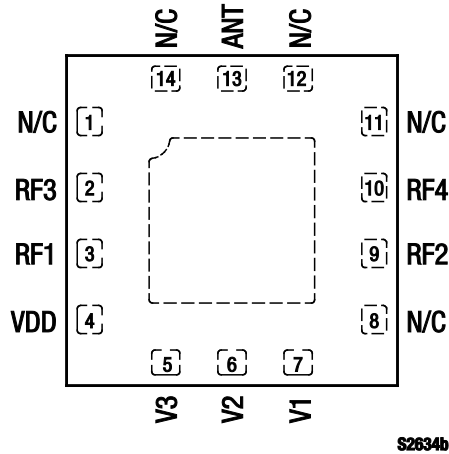

Figure 2. SKY13414-485LF Pinout – 14-Pin QFN (Top View)

Table 1. SKY13414-485LF Signal Descriptions

Pin #	Name	Description	Pin #	Name	Description
1	N/C	Not connected	8	N/C	Not connected
2	RF3	RF output path 3	9	RF2	RF output path 2
3	RF1	RF output path 1	10	RF4	RF output path 4
4	VDD	DC power supply	11	N/C	Not connected
5	V3	DC control voltage 3	12	N/C	Not connected
6	V2	DC control voltage 2	13	ANT	Antenna port
7	V1	DC control voltage 1	14	N/C	Not connected

Note: Bottom ground paddles must be connected to ground.

Table 2. SKY13414-485LF Absolute Maximum Ratings (Note 1)

Parameter	Symbol	Minimum	Maximum	Units
Supply voltage	V _{DD}	2.5	5.0	V
Control voltage (V1, V2, and V3)	V _{CTL}	-0.5	+3.0	V
RF input power (RF1 to RF4)	P _{IN}		+39	dBm
RF input power (50_Ω)	P _{IN}		+27	dBm
Operating temperature	T _{OP}	-40	+90	°C
Storage temperature	T _{STG}	-55	+150	°C

Note 1: Exposure to maximum rating conditions for extended periods may reduce device reliability. There is no damage to device with only one parameter set at the limit and all other parameters set at or below their nominal value. Exceeding any of the limits listed here may result in permanent damage to the device.

CAUTION: Although this device is designed to be as robust as possible, Electrostatic Discharge (ESD) can damage this device. This device must be protected at all times from ESD. Static charges may easily produce potentials of several kilovolts on the human body or equipment, which can discharge without detection. Industry-standard ESD precautions should be used at all times. The SKY13414-485LF ESD threshold level is 1000 VDC using Human Body Model (HBM) testing.

Functional Description

The SKY13414-485LF includes an internal negative voltage generator and decoder that eliminate the need for external DC blocking capacitors on the RF ports. No external components are required for proper operation. DC decoupling capacitors may be added on the VDD and control lines if necessary.

Switching is controlled by three control voltage inputs, V1, V2, and V3. Depending on the logic voltage level applied to the control pins, the antenna pin is connected to one of four switched RF outputs or a 50 Ω termination.

Shutdown mode is enabled by connecting all three control pins (V1, V2, and V3) to logic high. This mode reduces the overall current consumption of the device to 5 μA typical.

The recommended startup sequence is:

1. Apply VDD
2. Apply V1, V2, and V3 voltages
3. Apply RF input

The device must be turned off in reverse order.

Electrical and Mechanical Specifications

The absolute maximum ratings of the SKY13414-485LF are provided in Table 2. Electrical specifications are provided in Table 3.

The state of the SKY13414-485LF is determined by the logic shown in Table 4.

Table 3. SKY13414-485LF General Electrical Specifications (Note 1)
(V_{DD} = 2.6 V, V₁ = V₂ = V₃ = 0/1.8 V, P_{IN} = 0 dBm, T_{OP} = +25 °C, Characteristic Impedance [Z₀] = 50 Ω, Unless Otherwise Noted)

Parameter	Symbol	Test Condition (Note 2)	Min	Typical	Max	Units
DC Specifications						
Supply voltage	V _{DD}		2.5	3.0	4.8	V
Supply current	I _{DD}			40	50	μA
Control voltage: High Low	V _{CTL_H} V _{CTL_L}		1.35	1.80	3.00 0.3	V V
Control current	I _{CTL}	V _{CTL} = 1.8 V		0.5	1.0	μA
Shutdown mode supply current	I _{OFF}	V _{1/2/3} = 1.8 V, V _{DD} = 3 V		5		μA
Turn-on switching time	t _{ON}	50% of control voltage to 90% of final RF power, switching between RF1/2/3/4/5/6		1.4	2.0	μs
RF Specifications						
Insertion loss (ANT pin to RF1/2/3/4 pins)	IL	0.1 to 1.0 GHz		0.35	0.40	dB
		1.0 to 2.0 GHz		0.45	0.55	dB
		2.0 to 2.7 GHz		0.55	0.70	dB
Isolation (ANT pin to RF1/2/3/4 pins)	Iso	0.1 to 1.0 GHz	30	35		dB
		1.0 to 2.0 GHz	28	30		dB
		2.0 to 2.7 GHz	22	25		dB
Second harmonics (ANT pin to RF1/2/3/4 pins)	2fo	P _{IN} = +26 dBm, 0.1 to 3.0 GHz		+85	+80	dBc
Third harmonics (ANT pin to RF1/2/3/4 pins)	3fo	P _{IN} = +26 dBm, 0.1 to 3.0 GHz		+85	+80	dBc
0.1 dB Compression Point (ANT pin to RF1/2/3/4 pins)	P _{0.1dB}	0.8 GHz to 3.0 GHz		+38		dBm
3 rd Order Input Intercept Point	IIP ₃	@ 2.0 GHz, P _{IN} = +26 dBm, Δf = 1 MHz		+69		dBm

Table 4. SKY13414-485LF Control Logic

Control Pins			Switched RF Outputs					
V1 (Pin 7)	V2 (Pin 6)	V3 (Pin 5)	RF1 (Pin 3)	RF2 (Pin 9)	RF3 (Pin 2)	RF4 (Pin 10)	50 Ω	
0	0	0	Insertion Loss	Isolation	Isolation	Isolation	Isolation	
0	0	1	Isolation	Insertion Loss	Isolation	Isolation	Isolation	
0	1	0	Isolation	Isolation	Insertion Loss	Isolation	Isolation	
0	1	1	Isolation	Isolation	Isolation	Insertion Loss	Isolation	
1	0	0	Isolation	Isolation	Isolation	Isolation	Isolation	
1	0	1	Isolation	Isolation	Isolation	Isolation	50 Ω	
1	1	1	Shutdown mode					

Note 1: "High" = 1.8 V; "Low" = 0 V. Any state other than that described in this Table places the switch into an undefined state. An undefined state will not damage the device.

Evaluation Board Description

The SKY13414-485LF Evaluation Board is used to test the performance of the SKY13414-485LF SP4T Switch. An Evaluation Board schematic diagram is provided in Figure 3. An assembly drawing for the Evaluation Board is shown in Figure 4.

Package Dimensions

The PCB layout footprint for the SKY13414-485LF is provided in Figure 5. Typical case markings are shown in Figure 6. Package dimensions for the 14-pin QFN are shown in Figure 7, and tape and reel dimensions are provided in Figure 8.

Package and Handling Information

Instructions on the shipping container label regarding exposure to moisture after the container seal is broken must be followed. Otherwise, problems related to moisture absorption may occur when the part is subjected to high temperature during solder assembly.

THE SKY13414-485LF is rated to Moisture Sensitivity Level 1 (MSL1) at 260 °C. It can be used for lead or lead-free soldering. For additional information, refer to the Skyworks Application Note, *Solder Reflow Information*, document number 200164.

Care must be taken when attaching this product, whether it is done manually or in a production solder reflow environment. Production quantities of this product are shipped in a standard tape and reel format.

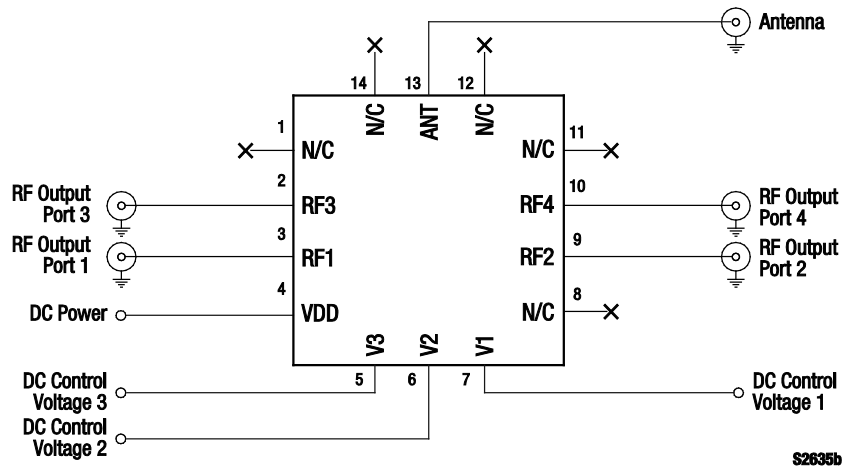

S2635b

Figure 3. SKY13414-485LF Evaluation Board Schematic

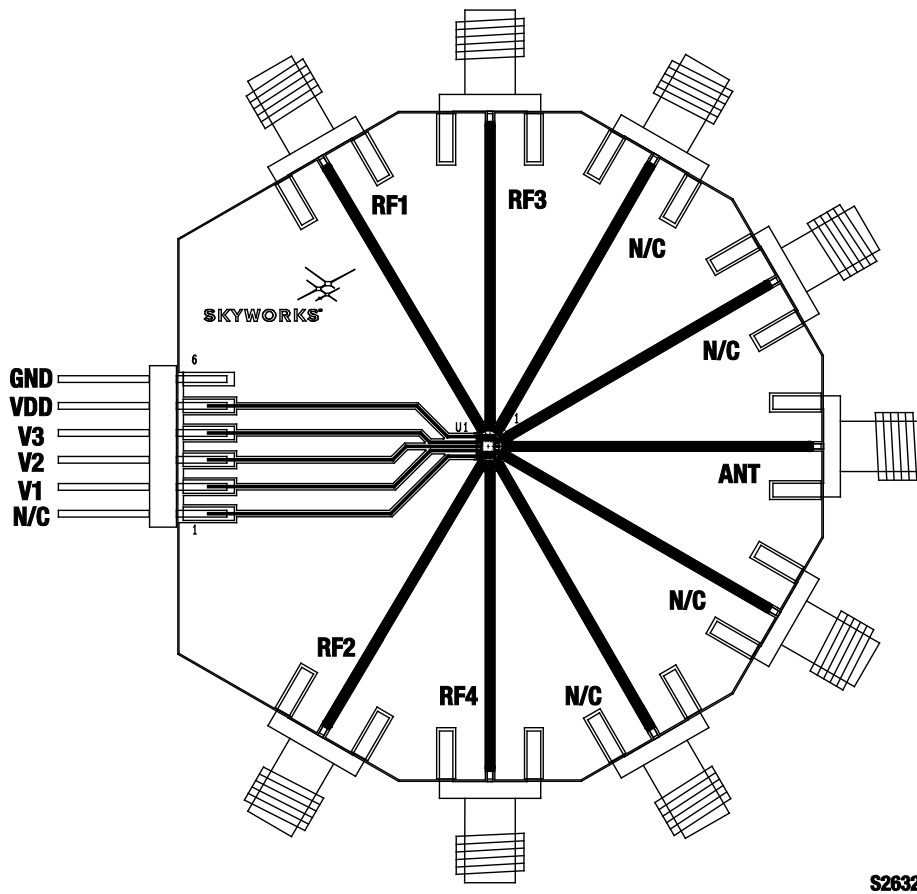

S2632b

Figure 4. SKY13414-485LF Evaluation Board Assembly Diagram

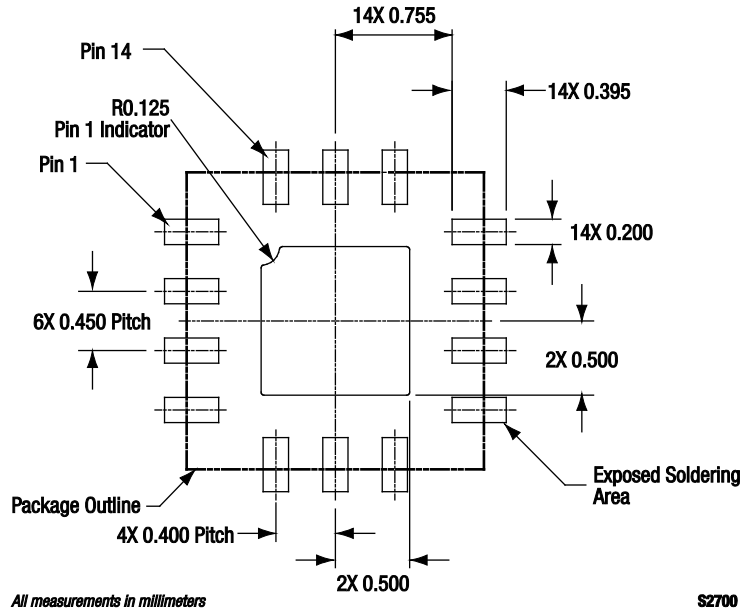

Figure 5. SKY13414-485LF PCB Layout Footprint (Top View)

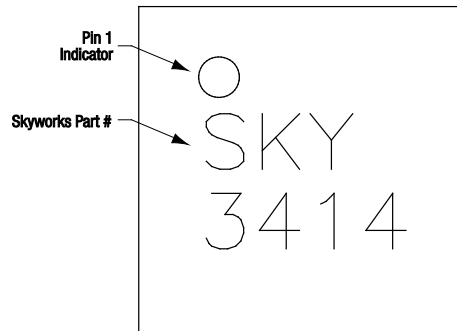
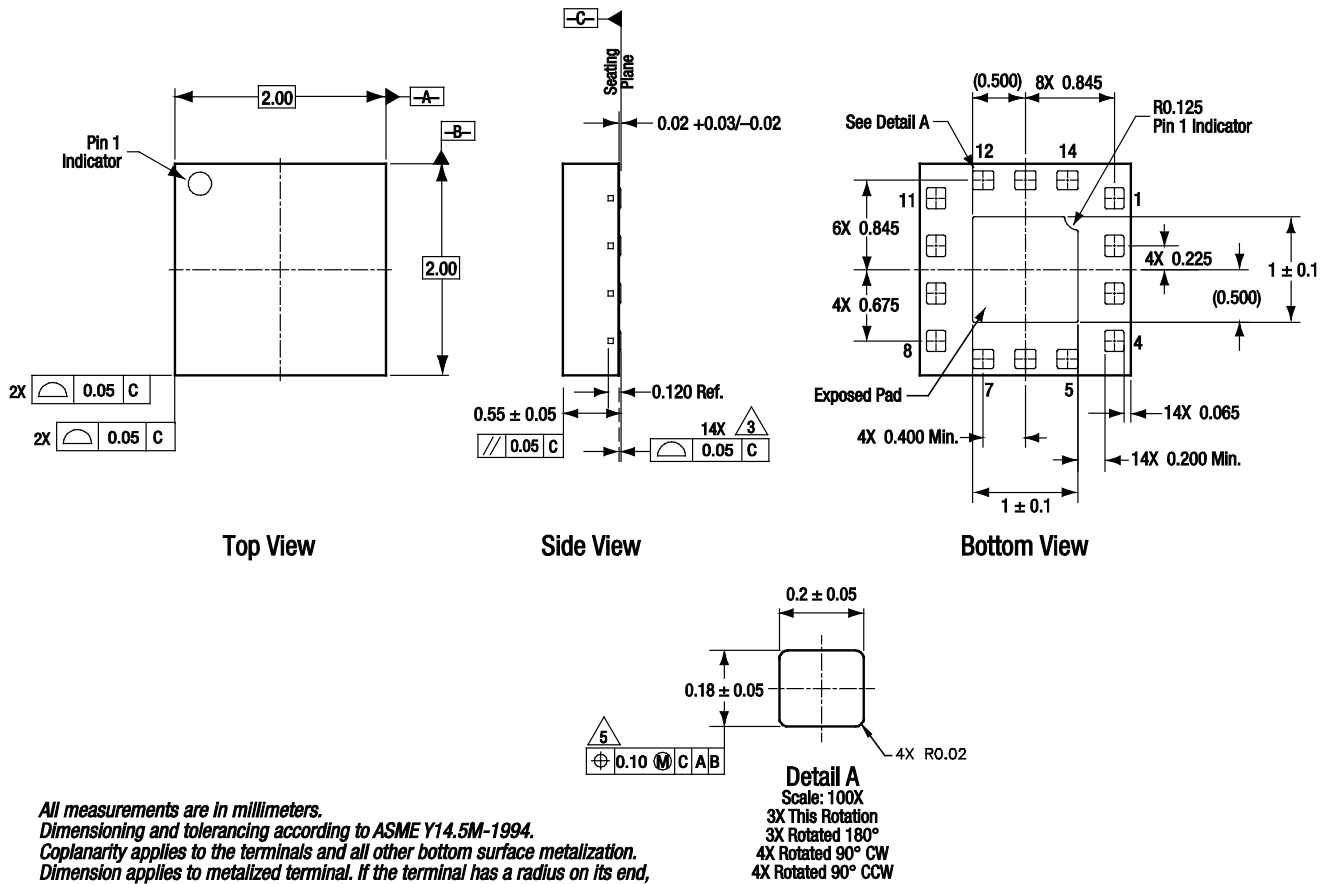

Figure 6. Typical Part Markings (Top View)



S2799

Figure 7. SKY13414-485LF 14-Pin QFN Package Dimensions

Ordering Information

Model Name	Manufacturing Part Number	Evaluation Board Part Number
SKY13414-485LF 0.1-3.0 GHz SP4T Switch	SKY13414-485LF	SKY13414-485LF-EVB

Copyright © 2011, 2012 Skyworks Solutions, Inc. All Rights Reserved.

Information in this document is provided in connection with Skyworks Solutions, Inc. ("Skyworks") products or services. These materials, including the information contained herein, are provided by Skyworks as a service to its customers and may be used for informational purposes only by the customer. Skyworks assumes no responsibility for errors or omissions in these materials or the information contained herein. Skyworks may change its documentation, products, services, specifications or product descriptions at any time, without notice. Skyworks makes no commitment to update the materials or information and shall have no responsibility whatsoever for conflicts, incompatibilities, or other difficulties arising from any future changes.

No license, whether express, implied, by estoppel or otherwise, is granted to any intellectual property rights by this document. Skyworks assumes no liability for any materials, products or information provided hereunder, including the sale, distribution, reproduction or use of Skyworks products, information or materials, except as may be provided in Skyworks Terms and Conditions of Sale.

THE MATERIALS, PRODUCTS AND INFORMATION ARE PROVIDED "AS IS" WITHOUT WARRANTY OF ANY KIND, WHETHER EXPRESS, IMPLIED, STATUTORY, OR OTHERWISE, INCLUDING FITNESS FOR A PARTICULAR PURPOSE OR USE, MERCHANTABILITY, PERFORMANCE, QUALITY OR NON-INFRINGEMENT OF ANY INTELLECTUAL PROPERTY RIGHT; ALL SUCH WARRANTIES ARE HEREBY EXPRESSLY DISCLAIMED. SKYWORKS DOES NOT WARRANT THE ACCURACY OR COMPLETENESS OF THE INFORMATION, TEXT, GRAPHICS OR OTHER ITEMS CONTAINED WITHIN THESE MATERIALS. SKYWORKS SHALL NOT BE LIABLE FOR ANY DAMAGES, INCLUDING BUT NOT LIMITED TO ANY SPECIAL, INDIRECT, INCIDENTAL, STATUTORY, OR CONSEQUENTIAL DAMAGES, INCLUDING WITHOUT LIMITATION, LOST REVENUES OR LOST PROFITS THAT MAY RESULT FROM THE USE OF THE MATERIALS OR INFORMATION, WHETHER OR NOT THE RECIPIENT OF MATERIALS HAS BEEN ADVISED OF THE POSSIBILITY OF SUCH DAMAGE.

Skyworks products are not intended for use in medical, lifesaving or life-sustaining applications, or other equipment in which the failure of the Skyworks products could lead to personal injury, death, physical or environmental damage. Skyworks customers using or selling Skyworks products for use in such applications do so at their own risk and agree to fully indemnify Skyworks for any damages resulting from such improper use or sale.

Customers are responsible for their products and applications using Skyworks products, which may deviate from published specifications as a result of design defects, errors, or operation of products outside of published parameters or design specifications. Customers should include design and operating safeguards to minimize these and other risks. Skyworks assumes no liability for applications assistance, customer product design, or damage to any equipment resulting from the use of Skyworks products outside of stated published specifications or parameters.

Skyworks, the Skyworks symbol, and "Breakthrough Simplicity" are trademarks or registered trademarks of Skyworks Solutions, Inc., in the United States and other countries. Third-party brands and names are for identification purposes only, and are the property of their respective owners. Additional information, including relevant terms and conditions, posted at www.skyworksinc.com, are incorporated by reference.