

PRELIMINARY DATA SHEET

SKY13412-487LF: 0.4-2.7 GHz SP12T Switch with GPIO Interface

Applications

- 2G/3G/4G multimode cellular handsets (LTE, UMTS, CDMA2000, EDGE, GSM)
- Embedded data cards

Features

- Broadband frequency range: 0.4 to 2.7 GHz
- Low insertion loss
- High isolation and linearity
- Integrated GSM harmonic filter
- Integrated GPIO interface
- Ten TRX ports, one GSM low band transmit port, and one GSM high band transmit port
- Small QFN (30-pin, 3.0 x 3.8 x 0.75 mm) package (MSL1, 260 °C per JEDEC J-STD-020)



Skyworks Green™ products are compliant with all applicable legislation and are halogen-free. For additional information, refer to *Skyworks Definition of Green™*, document number SQ04-0074.

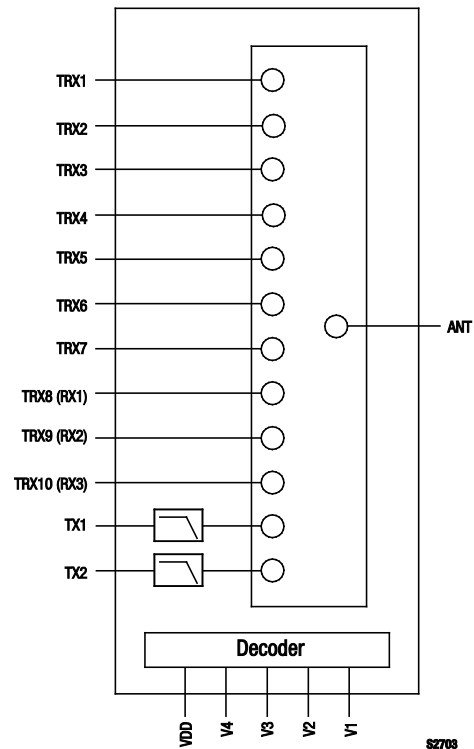

Figure 1. SKY13412-487LF Block Diagram

Description

The SKY13412-487LF is a Single Pole, Twelve Throw (SP12T) antenna switch with integrated GSM transmit harmonic filter. The SKY13412-487LF maintains a high linearity, high isolation, and low insertion loss performance, which makes it an ideal choice for UMTS, CDMA2000, EDGE, GSM, and LTE applications.

The design features two dedicated GSM transmit ports. The remaining ten ports are suitable for WCDMA transmit/receive and GSM receive functions. Three transmit ports have been specifically designed to provide optimal LTE Band 13 performance. The switch exhibits an excellent triple beat ratio and 2nd/3rd order modulation distortion performance.

Switching is controlled by an integrated GPIO interface. Depending on the logic applied to the decoder, the antenna pin is connected to one of 12 switched RF ports using a low insertion loss path, while the paths between the antenna pin and the other RF pins are in a high isolation state. No external DC blocking capacitors are required on the RF paths.

The SKY13412-487LF is manufactured in a compact, 3.0 x 3.8 x 0.75 mm, 30-pin surface mount Quad Flat No-Lead (QFN) package.

A functional block diagram is shown in Figure 1. The pin configuration and package are shown in Figure 2. Signal pin assignments and functional pin descriptions are provided in Table 1.

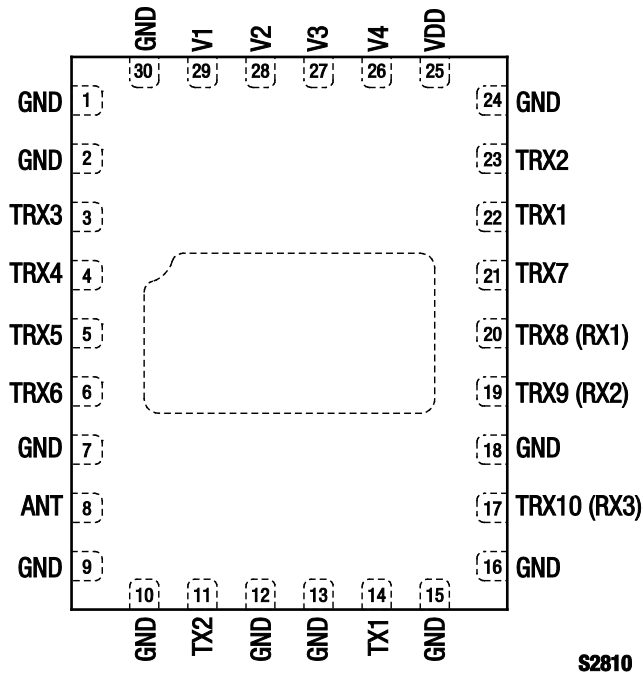

Figure 2. SKY13412-487LF Pinout – 30-Pin QFN (Top View)

Table 1. SKY13412-487LF Signal Descriptions

Pin #	Name	Description	Pin #	Name	Description
1	GND	Ground	16	GND	Ground
2	GND	Ground	17	TRX10 (RX3)	RF input/output port 10 (receive 3)
3	TRX3	RF input/output port 3. Optimized for LTE Band 13 (704 to 787 MHz)	18	GND	Ground
4	TRX4	RF input/output port 4	19	TRX9 (RX2)	RF input/output port 9 (receive 2)
5	TRX5	RF input/output port 5	20	TRX8 (RX1)	RF input/output port 8 (receive 1)
6	TRX6	RF input/output port 6	21	TRX7	RF input/output port 7 optimized for LTE Band 13 (704 to 787 MHz)
7	GND	Ground	22	TRX1	RF input/output port 1 optimized for LTE Band 13 (704 to 787 MHz)
8	ANT	Antenna RF port	23	TRX2	RF input/output port 2
9	GND	Ground	24	GND	Ground
10	GND	Ground	25	VDD	DC power supply
11	TX2	GSM high band transmit RF input port with integrated harmonic filter	26	V4	DC input control voltage 4
12	GND	Ground	27	V3	DC input control voltage 3
13	GND	Ground	28	V2	DC input control voltage 2
14	TX1	GSM low band transmit RF input port with integrated harmonic filter	29	V1	DC input control voltage 1
15	GND	Ground	30	GND	Ground

Note: Bottom ground paddles must be connected to ground.

Table 2. SKY13412-487LF Absolute Maximum Ratings

Parameter	Symbol	Minimum	Maximum	Units
Power supply	VDD	2.5	5.0	V
Digital control signals (V1, V2, V3, V4)	VCTRL	-0.5	+3.5	V
RF input power:	PIN			
TX1 pin			+36	dBm
TX2 pin			+34	dBm
All TRXx pins			+31	dBm
Storage temperature	TSTG	-55	+150	°C
Operating temperature	TOP	-35	+90	°C

Note: Exposure to maximum rating conditions for extended periods may reduce device reliability. There is no damage to device with only one parameter set at the limit and all other parameters set at or below their nominal value. Exceeding any of the limits listed here may result in permanent damage to the device.

CAUTION: Although this device is designed to be as robust as possible, Electrostatic Discharge (ESD) can damage this device. This device must be protected at all times from ESD. Static charges may easily produce potentials of several kilovolts on the human body or equipment, which can discharge without detection. Industry-standard ESD precautions should be used at all times.

Electrical and Mechanical Specifications

The absolute maximum ratings of the SKY13412-487LF are provided in Table 2. Electrical specifications are provided in Table 3. Table 4 provides the control logic for the SKY13412-487LF.

Figure 3 illustrates the test setup used to measure intermodulation products. This industry standardized test is used to simulate the WCDMA Band 1 linearity of the antenna switch. A

+20 dBm Continuous Wave (CW) signal, f_{FUND} , is sequentially applied to the TRX1 through TRX8 ports, while a -15 dBm CW blocker signal, f_{BLK} , is applied to the ANT port.

The resulting 3rd Order Intermodulation Distortion (IMD3), f_{RX} , is measured over all phases of f_{FUND} . The SKY13412-487LF exhibits exceptional performance for all TRXx ports.

Table 3. SKY13412-487LF Electrical Specifications (Note 1) (1 of 3)
(V_{DD} = 2.85 V, T_{OP} = +25 °C, Characteristic Impedance [Z₀] = 50 Ω, Unless Otherwise Noted)

Parameter	Symbol	Test Condition	Min	Typical	Max	Units
RF Specifications						
Insertion loss	IL	Transmit low band, 915 MHz		1.10		dB
		Transmit high band, 1910 MHz		1.10		dB
		TRX1/3/7 Band 13, 704 to 787 MHz		0.40		dB
		TRXx ports, 960 MHz, +26 dBm		0.50		dB
		TRXx ports, 1990 MHz, +26 dBm		0.60		dB
		TRXx ports, 2170 MHz, +26 dBm		0.70		dB
		TRXx ports, 2690 MHz		0.95		dB
GSM harmonic attenuation	H2LB	Transmit low band to ANT, 2fo 1648 to 1830 MHz		28		dB
	H3LB	Transmit low band to ANT, 3fo 2472 to 2745 MHz		28		dB
	H4LB	Transmit low band to ANT, 2fo 3296 to 3660 MHz		25		dB
	H2HB	Transmit high band to ANT, 2fo 3420 to 3820 MHz		28		dB
	H3HB	Transmit high band to ANT, 3fo 5130 to 5730 MHz		28		dB
Large signal harmonics	TXLB_HARM	Transmit GSM low band, PIN <+34.5 dBm, VSWR = 1:1			-45	dBm
	TXLB_HARM_VSWR	Transmit GSM low band, PIN <+34.5 dBm, VSWR = 5:1, all phases			-36	dBm
	TXHB_HARM	Transmit GSM high band, PIN <+32 dBm, VSWR = 1:1			-45	dBm
	TXHB_HARM_VSWR	Transmit GSM high band, PIN <+32 dBm, VSWR = 5:1, all phases			-36	dBm
	B13_HARM	ANT to TRX1/3/7 ports @786.5 MHz, PIN <+25 dBm, VSWR = 1:1			-80	dBm
	TRXLB_HARM	Transmit WCDMA low band, PIN <+26 dBm, VSWR = 1:1			-60	dBm

Table 3. SKY13412-487LF Electrical Specifications (Note 1) (2 of 3)
(V_{DD} = 2.85 V, T_{OP} = +25 °C, Characteristic Impedance [Z₀] = 50 Ω, Unless Otherwise Noted)

Parameter	Symbol	Test Condition	Min	Typical	Max	Units
RF Specifications (continued)						
Large signal harmonics (continued)	TRXLB_HARM_VSWR	Transmit WCDMA low band, P _{IN} <+26 dBm, VSWR = 5:1			-45	dBm
	TRXHB_HARM	Transmit WCDMA high band, P _{IN} <+26 dBm, VSWR = 1:1, all phases			-60	dBm
	TRXHB_HARM_VSWR	Transmit WCDMA high band, P _{IN} <+26 dBm, VSWR = 5:1, all phases			-45	dBm
Isolation	Iso_TX1/2_1800	TX1 to TX2, P _{IN} <+34.5 dBm, @ 1648 to 1830 MHz	30			dB
	Iso_TX1/TRX_900	TX1 to TRX pins, P _{IN} <+34.5 dBm, @ 824 to 915 MHz	35			dB
	Iso_TX1/RX_900	TX1 to receive ports (Note 2), P _{IN} <+10 dBm, @ 869 to 960 MHz	35			dB
	Iso_TX2/TRX_1800	TX2 to TRX pins, P _{IN} <+32 dBm, @ 1710 to 1910 MHz	32			dB
	Iso_TX2/RX_1800	TX2 to receive ports (Note 2), P _{IN} <+32 dBm, @ 1805 to 1930 MHz	32			dB
	Iso_RX2/RX3_1990	TRX9 (RX2) to ANT when TRX10 (RX3) active, P _{IN} <+26 dBm, @ 1805 to 1990 MHz	33			dB
	Iso_RX3/RX2_1990	TRX10 (RX3) to ANT when TRX9 (RX2) active, P _{IN} <+26 dBm, @ 1805 to 1990 MHz	33			dB
	Iso_TRX/RX_1990	TRX pins to receive ports (Note 2), P _{IN} <+26 dBm, @ 1710 to 2170 MHz	30			dB
	Iso_TRX/TRX_2170	TRX pins to TRX pins, P _{IN} <+26 dBm, @ 1710 to 2170 MHz, TRX1 to TRX8, TRX2 to TRX9, TRX3 to TRX10, TRX3 to TRX5, TRX4 to TRX6 (non-adjacent pins)	23			dB

Table 3. SKY13412-487LF Electrical Specifications (Note 1) (3 of 3)
(V_{DD} = 2.85 V, T_{OP} = +25 °C, Characteristic Impedance [Z₀] = 50 Ω, Unless Otherwise Noted)

Parameter	Symbol	Test Condition	Min	Typical	Max	Units
RF Specifications (continued)						
Isolation (continued)	Iso_TRX/TRX_2170	TRXx to TRXx, PIN <+26 dBm, @ 1710 to 2170 MHz, TRX1 to TRX2, TRX3 to TRX4, TRX4 to TRX5, TRX5 to TRX6, TRX1 to TRX7 (adjacent pins)	17			dB
2nd Order Intermodulation Distortion	IMD2	CW carrier on TRXx ports with P _{OUT} = +20 dBm, CW interferer on ANT port with PIN = -15dBm, all blocker frequencies		-110	-105	dBm
3rd Order Intermodulation Distortion	IMD3	CW carrier on TRXx ports with P _{OUT} = +20 dBm, CW interferer on ANT port with PIN = -15dBm, all blocker frequencies		-110	-105	dBm
DC Specifications						
Supply voltage	V _{DD}		2.50	2.85	3.30	V
Supply current: GSM850/EGSM900/DCS1800/ PCS1900 transmit WCDMA/CDMA2000 transmit/receive	I _{DD}			50	100	μA
				50	100	μA
Digital control signals: High Low Current	V1, V2, V3, V4		1.35 0	1.80	3.10	V
					0.45	V
					5	μA
DC supply turn-on/turn-off time				2	5	μs
RF path switching time		Between the ANT port and any TX1/2 or TRXx ports			2	μs
Supply ripple					20	mVp-p

Note 1: Performance is guaranteed only under the conditions listed in this Table.

Note 2: Dedicated receive ports are TRX8 (RX1), TRX9 (RX2), or TRX10 (RX3).

Table 4. SKY13412-487LF Mode Control Logic

Insertion Loss State	V1 (Pin 29)	V2 (Pin 28)	V3 (Pin 27)	V4 (Pin 26)
Standby (all ports in isolation state)	0	0	0	0
TX1	1	1	0	0
TX2	1	0	0	0
TRX10 (RX3)	0	1	0	0
TRX9 (RX2)	0	1	1	0
TRX8 (RX1)	0	0	1	0
TRX7	0	0	0	1
TRX1	1	0	1	0
TRX2	1	1	1	0
TRX3	1	0	1	1
TRX4	1	1	1	1
TRX5	1	0	0	1
TRX6	1	1	0	1

Note: "1" = 1.8 V typical. "0" = 0 V to +0.2 V. Any state other than described in this Table places the switch into an undefined state. An undefined state will not damage the device.

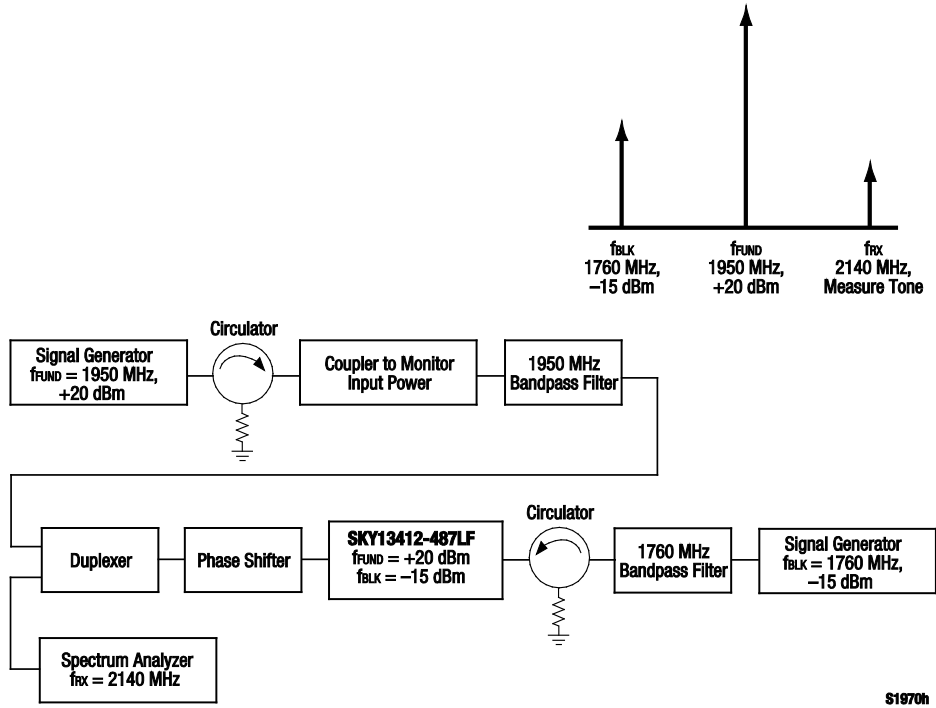

S1970h

Figure 3. 3rd Order Intermodulation Test Setup

Evaluation Board Description

The SKY13412-487LF Evaluation Board is used to test the performance of the SKY13412-487LF SP12T Switch. An Evaluation Board schematic diagram is provided in Figure 4. A recommended ESD protection circuit diagram is provided in Figure 5. An assembly drawing for the Evaluation Board is shown in Figure 6.

Package Dimensions

The PCB layout footprint for the SKY13412-487LF is provided in Figure 7. Typical case markings are shown in Figure 8. Package dimensions for the 30-pin QFN are shown in Figure 9, and tape and reel dimensions are provided in Figure 10.

Package and Handling Information

Instructions on the shipping container label regarding exposure to moisture after the container seal is broken must be followed. Otherwise, problems related to moisture absorption may occur when the part is subjected to high temperature during solder assembly.

The SKY13412-487LF is rated to Moisture Sensitivity Level 1 (MSL1) at 260 °C. It can be used for lead or lead-free soldering. For additional information, refer to the Skyworks Application Note, *Solder Reflow Information*, document number 200164.

Care must be taken when attaching this product, whether it is done manually or in a production solder reflow environment. Production quantities of this product are shipped in a standard tape and reel format.

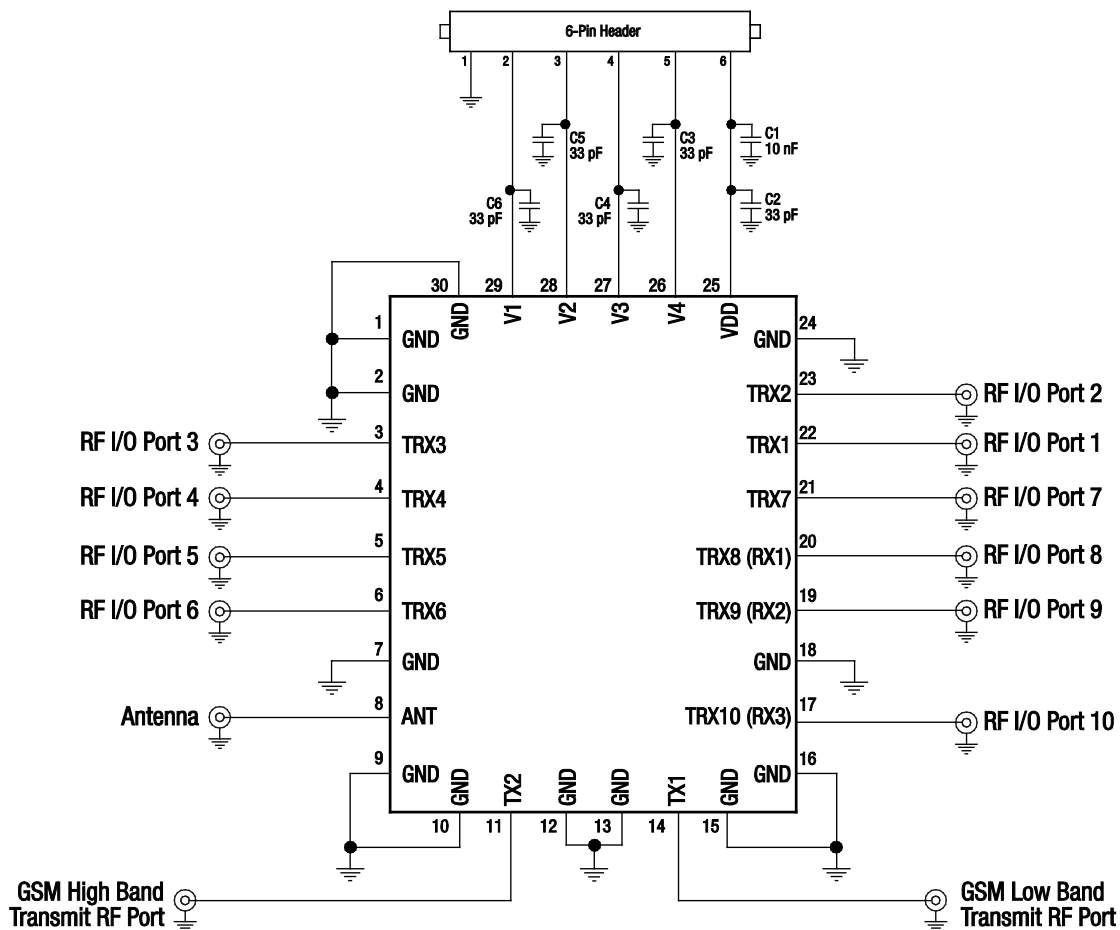

S2811

Figure 4. SKY13412-487LF Evaluation Board Schematic

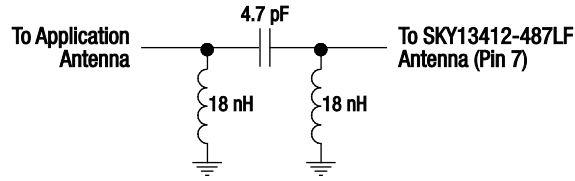

ESD Circuit 1

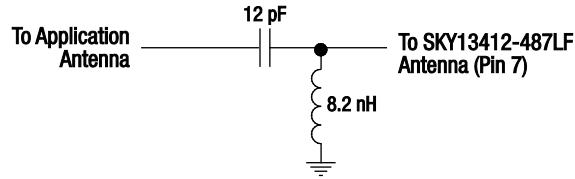

ESD Circuit 2

S2520e

Figure 5. SKY13412-487LF Recommended ESD Protection Circuits

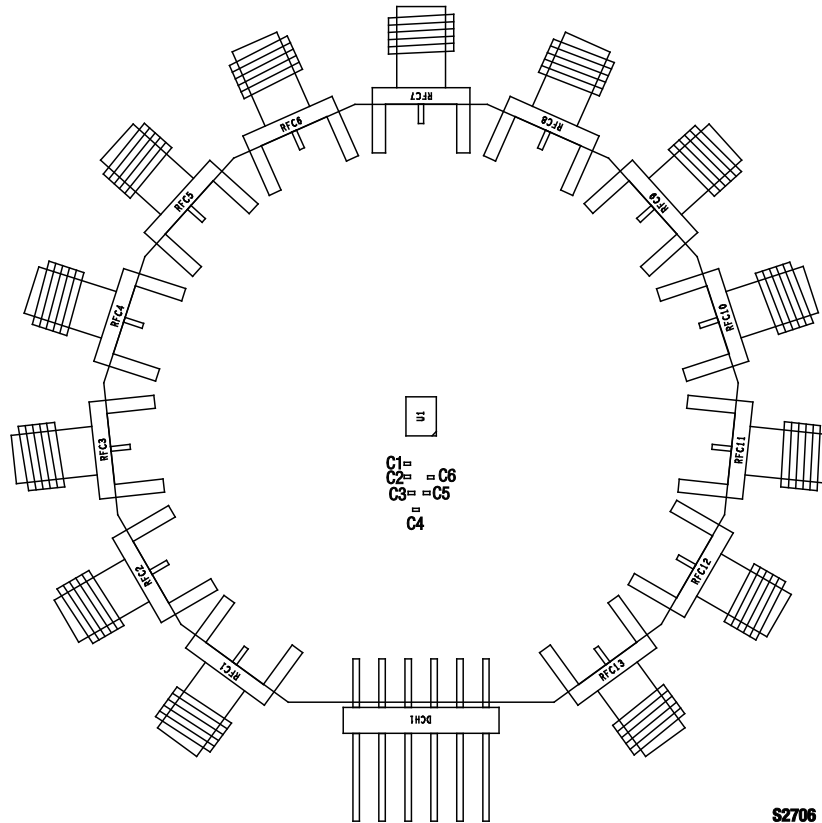

S2706

Figure 6. SKY13412-487LF Evaluation Board Assembly Diagram

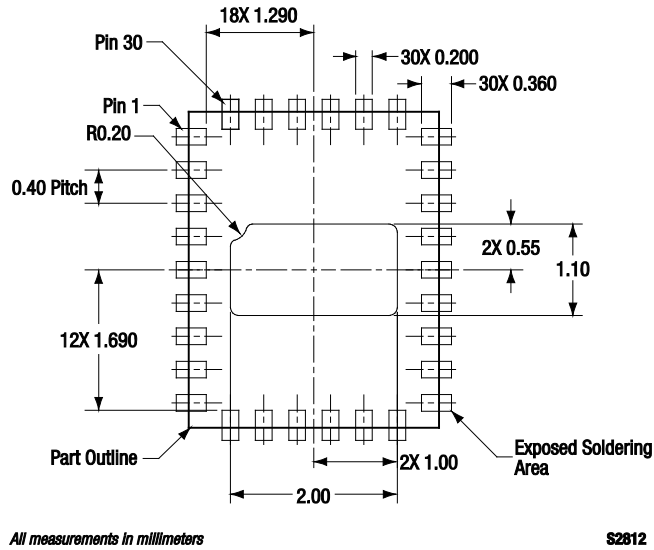
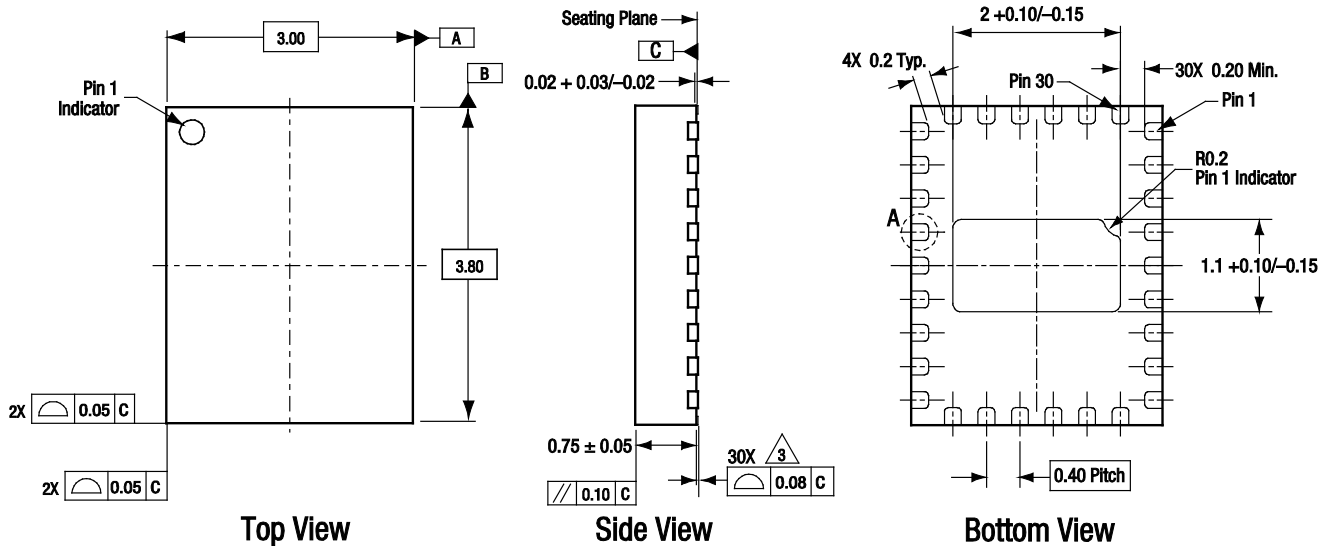

Figure 7. SKY13412-487LF PCB Layout Footprint (Top View)

*** TBD ***

Figure 8. Typical Part Markings (Top View)



All measurements are in millimeters.
 Dimensioning and tolerancing according to ASME Y14.5M-1994.
 Coplanarity applies to the terminals and all other bottom surface metalization.
 Dimension applies to metalized terminal and is measured between 0.15 mm and 0.30 mm from terminal tip.

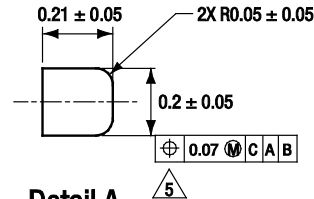

Detail A
 Scale: 80X
 30 Places

S2809

Figure 9. SKY13412-487LF 30-Pin QFN Package Dimensions

*** TBD ***

Figure 10. SKY13412-487LF Tape and Reel Dimensions

Ordering Information

Model Name	Manufacturing Part Number	Evaluation Board Part Number
SKY13412-487LF 0.4-2.7 GHz SP12T Switch	SKY13412-487LF	SKY13412-487LF-EVB

Copyright © 2012 Skyworks Solutions, Inc. All Rights Reserved.

Information in this document is provided in connection with Skyworks Solutions, Inc. ("Skyworks") products or services. These materials, including the information contained herein, are provided by Skyworks as a service to its customers and may be used for informational purposes only by the customer. Skyworks assumes no responsibility for errors or omissions in these materials or the information contained herein. Skyworks may change its documentation, products, services, specifications or product descriptions at any time, without notice. Skyworks makes no commitment to update the materials or information and shall have no responsibility whatsoever for conflicts, incompatibilities, or other difficulties arising from any future changes.

No license, whether express, implied, by estoppel or otherwise, is granted to any intellectual property rights by this document. Skyworks assumes no liability for any materials, products or information provided hereunder, including the sale, distribution, reproduction or use of Skyworks products, information or materials, except as may be provided in Skyworks Terms and Conditions of Sale.

THE MATERIALS, PRODUCTS AND INFORMATION ARE PROVIDED "AS IS" WITHOUT WARRANTY OF ANY KIND, WHETHER EXPRESS, IMPLIED, STATUTORY, OR OTHERWISE, INCLUDING FITNESS FOR A PARTICULAR PURPOSE OR USE, MERCHANTABILITY, PERFORMANCE, QUALITY OR NON-INFRINGEMENT OF ANY INTELLECTUAL PROPERTY RIGHT; ALL SUCH WARRANTIES ARE HEREBY EXPRESSLY DISCLAIMED. SKYWORKS DOES NOT WARRANT THE ACCURACY OR COMPLETENESS OF THE INFORMATION, TEXT, GRAPHICS OR OTHER ITEMS CONTAINED WITHIN THESE MATERIALS. SKYWORKS SHALL NOT BE LIABLE FOR ANY DAMAGES, INCLUDING BUT NOT LIMITED TO ANY SPECIAL, INDIRECT, INCIDENTAL, STATUTORY, OR CONSEQUENTIAL DAMAGES, INCLUDING WITHOUT LIMITATION, LOST REVENUES OR LOST PROFITS THAT MAY RESULT FROM THE USE OF THE MATERIALS OR INFORMATION, WHETHER OR NOT THE RECIPIENT OF MATERIALS HAS BEEN ADVISED OF THE POSSIBILITY OF SUCH DAMAGE.

Skyworks products are not intended for use in medical, lifesaving or life-sustaining applications, or other equipment in which the failure of the Skyworks products could lead to personal injury, death, physical or environmental damage. Skyworks customers using or selling Skyworks products for use in such applications do so at their own risk and agree to fully indemnify Skyworks for any damages resulting from such improper use or sale.

Customers are responsible for their products and applications using Skyworks products, which may deviate from published specifications as a result of design defects, errors, or operation of products outside of published parameters or design specifications. Customers should include design and operating safeguards to minimize these and other risks. Skyworks assumes no liability for applications assistance, customer product design, or damage to any equipment resulting from the use of Skyworks products outside of stated published specifications or parameters.

Skyworks, the Skyworks symbol, and "Breakthrough Simplicity" are trademarks or registered trademarks of Skyworks Solutions, Inc., in the United States and other countries. Third-party brands and names are for identification purposes only, and are the property of their respective owners. Additional information, including relevant terms and conditions, posted at www.skyworksinc.com, are incorporated by reference.