

MODELS 7274, 7276

7/8" Diameter

Plastic 10-Turn

Wirewound

Precision Potentiometer



2

MODEL STYLES

7274	6mm Shaft, 3/8" Bushing
7276	1/4" Shaft, 3/8" Bushing

ELECTRICAL

Resistance Range, Ohms	100 to 100K
Standard Resistance Tolerance	±5%
Independent Linearity	±0.25%
Power Rating, Watts	2.0 at 25°C derating to 0 at 105°C
Dielectric Strength	1,000V rms
Insulation Resistance, Minimum	1,000 Megohms
Noise, Maximum	100 Ohms
Actual Electrical Travel	3600° + 10° - 0°
Tap Tolerance	±3°
End Voltage, Maximum (% of input voltage)	0.25%

ENVIRONMENTAL (MIL-R-12934)

Operating Temperature Range	-25°C to +105°C
Temperature Cycling	5 cycles, -25°C to +105°C (5% ΔR)
Shock, 6ms Sawtooth	100G's (0.1ms discontinuity max.)
Vibration	10G's, 10 to 500 Hz (5% ΔR, 0.1ms discontinuity max.)
Moisture Resistance	Five 24 hour cycles (3% ΔR)
High Temperature Exposure	1,000 hours at 105°C (5% ΔR)
Rotational Load Life	500K shaft rev. + 900 hrs. at rated wattage at 25°C (5%ΔR)

Specifications subject to change without notice.

MECHANICAL

Total Mechanical Travel	3600° + 15° - 0°
Number of Gangs, Maximum	1
Weight, Nominal	0.42 oz.
Static Stop Strength, Maximum	60 oz.-in.
Backlash, Maximum	2°
Panel Nut Tightening Torque, Maximum	8 lb.-in.
Shaft End Play, Maximum	.010"
Shaft Radial Play, Maximum	.010"
Start/Run Torque, Maximum	1.5 oz.-in.

STANDARD RESISTANCE VALUES, OHMS

Total Resistance	Theoretical Resolution (% Nominal)	Tempco of Wire
100	0.059	±20 ppm/°C
200	0.037	±20 ppm/°C
500	0.030	±20 ppm/°C
1K	0.024	±20 ppm/°C
2K	0.020	±20 ppm/°C
5K	0.018	±20 ppm/°C
10K	0.017	±20 ppm/°C
20K	0.016	±20 ppm/°C
50K	0.010	±20 ppm/°C
100K	0.009	±20 ppm/°C

METRIC CONVERSIONS

1 in.	25.4 mm	1 oz.-in.	0,007 N-m
1 oz.	28.4 gm	1 lb.-in.	0,113 N-m

OUTLINE DIMENSIONS (Inch/mm)

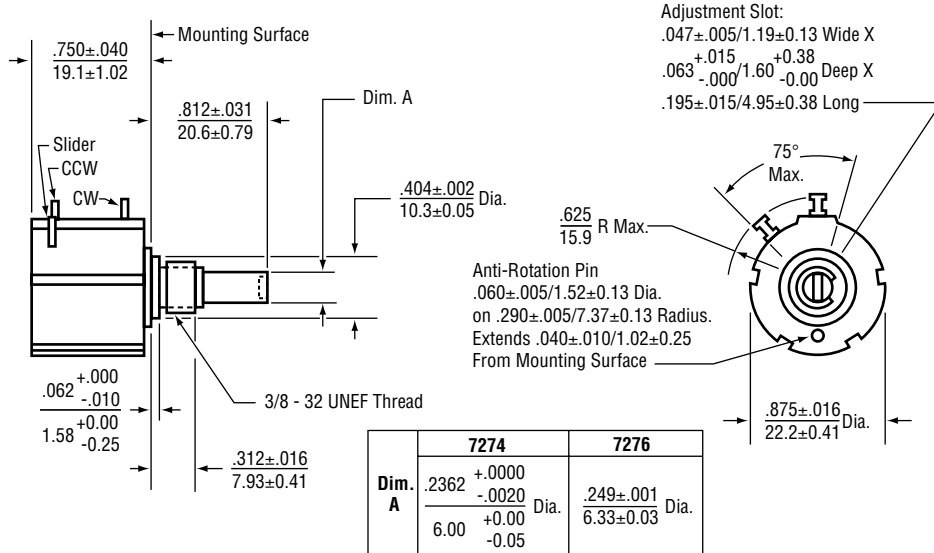

2

OPTIONAL TERMINAL CONFIGURATION

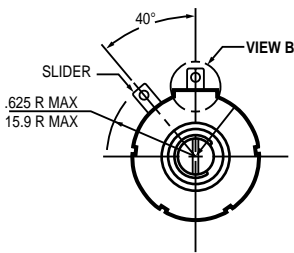

Use Special Feature Code "FT" to order.

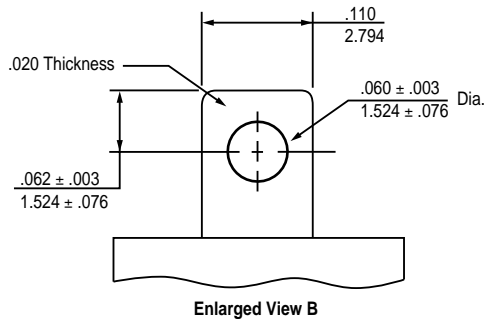

SPECIAL FEATURES

Center Tap	CT
Linearity Tape	LT
Flatted Shaft	FS
Shaft Lock	SL
Gold Plated Solder Lug Terminals (see optional terminal configuration)	FT

ORDERING INFORMATION

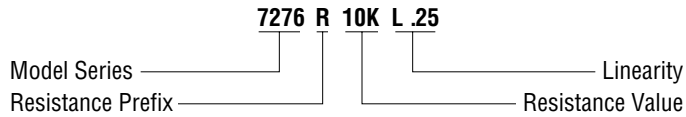

MATCHING TURNS COUNTING DIALS

2606, 2606S, 2607, 2607S, 2626, 2627, 2646, 2646S, 2647, 2647S, 2126, RB

CIRCUIT DIAGRAM

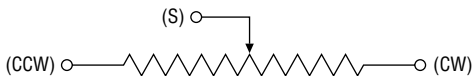

NOTES

Metric equivalents, based on 1 inch = 25.4mm are rounded to the same number of significant figures as in the original English units and are provided for general information only.

Tolerances unless otherwise specified:
Linear = $\pm .01$ inches
(.25mm)
Angular = ± 2 degrees

