

Model 7280

7/8" Diameter

10 Turn Wirewound

Precision Potentiometer



MODEL STYLES AVAILABLE

7281	1/8" Shaft, 1/4" Bushing
7283	1/8" Shaft, Servo
7284	6 mm shaft, 3/8" Bushing
7286	1/4" Shaft, 3/8" Bushing
7288 (for heavy side load applications)	1/4" Shaft, 3/8" Bushing

ELECTRICAL¹

Resistance Range	100 to 100K ohms
Standard Resistance Tolerance	±5%
Minimum Practical Resistance Tolerance	±1%
Independent Linearity ²	±0.25%
Minimum Practical Independent Linearity	±0.15% (<300 ohms), ±0.075% (≥300 ohms)
Power Rating	2.0 Watts at 70°C, derating to 0 at 125°C
Dielectric Strength	1,000 V rms
Insulation Resistance	1,000 Megohms minimum
Noise	100 ohms maximum
Actual Electrical Travel	3600° +10° -0° (>100 ohms), 3600° +10° -5° (≤100 ohms)
End Voltage	maximum 0.25% of input voltage
Tap Tolerance	±3°

MECHANICAL

Total Mechanical Travel	3600° +15° -0°
Number of Gangs	2 maximum
Weight (single gang)	0.75 oz. nominal
Backlash	1° maximum
	7281, 7284, 7286, 7288
	7283
Static Stop Strength	maximum 60 oz.-in. 36 oz.-in.
Panel Nut Tightening Torque	maximum 25 lb.-in. n/a
Shaft End Play	maximum 0.010" 0.005"
Shaft Runout	maximum T.I.R. 0.003" 0.002"
Pilot Diameter Runout	maximum T.I.R. 0.004" 0.002"
Lateral Runout	maximum T.I.R. 0.005" 0.004"
Shaft Radial Play	maximum 0.003" 0.002"
Start/Run Torque (per gang)	maximum 0.8 oz.-in. 0.6 oz.-in.

¹ Specifications subject to change without notice.

² Linearity is measured between 1% and 99% of input voltage.

Model 7280

ENVIRONMENTAL (MIL-PRF-12934)

Operating Temperature Range	-40°C to +125°C dynamic, -55°C to +125°C static
Temperature Cycling	5 cycles, -55°C to +125°C, maximum 5% ΔR
Shock	6 ms Saw-tooth, 100 G's, 0.1 ms maximum discontinuity
Vibration	15 G's, 10 to 2,000 Hz, maximum 5% ΔR, 0.1 ms maximum discontinuity
Moisture Resistance	Five 24 hour cycles, maximum 3% ΔR
High Temperature Exposure	1,000 hours at 125°C, maximum 5% ΔR
Rotational Load Life (1 lb side load for 7288)	1M shaft revolutions + 900 hours at 2.0 Watts & 70°C, maximum 5% ΔR
Ingress Protection Rating (IP Code)	IP40

ORDERING INFORMATION

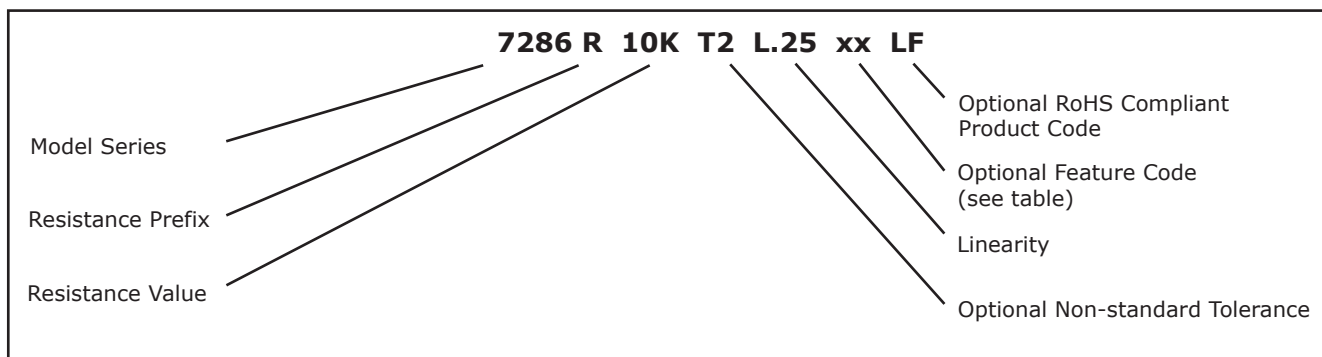

FEATURE CODES

Center Tap	CT
Linearity Tape	LT
Flatted Shaft	FS
Slotted Shaft (standard on single cup 7286 & 7288 without RS feature)	SS
Rear Shaft Extension (7281, 7286, 7288 single cup only)	RS
Shaft Lock (7281, 7286, 7288 only)	SL
High Torque 2-6 oz.-in. (7286 & 7288 only)	HT
Additional Gang	2G
Gold Plated Solder Lug Terminals (see optional terminal configuration)	FT

When multiple Feature Codes are used the P/N shall be in the same sequence as listed in this table (top to bottom).

CIRCUIT DIAGRAM

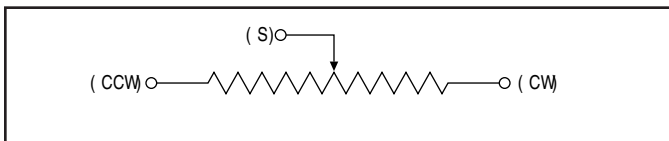

STANDARD RESISTANCE VALUES

Total Resistance (Ohms)	Theoretical Resolution (% nominal)	Tempco of wire (ppm/°C)
100	0.059	±20
200	0.037	±20
500	0.030	±20
1K	0.024	±20
2K	0.020	±20
5K	0.018	±20
10K	0.017	±20
20K	0.016	±20
50K	0.010	±20
100K	0.008	±20

BI Technologies Corporation

4200 Bonita Place, Fullerton, CA 92835 USA

Phone: 714 447 2345 Website: www.bitechnologies.com

October 2, 2012

Model 7280 page 2 of 4

Model 7280

MATCHING TURNS COUNTING DIALS

7281: RBJ, 2601, 2641

7286, 7288: RB, 2126, 2606, 2606S, 2607, 2607S, 2626, 2627, 2646, 2646S, 2647, 2647S

OUTLINE DRAWINGS

Models 7281, 7284, 7286, & 7288 Bushing Mount with Sleeve Bearing

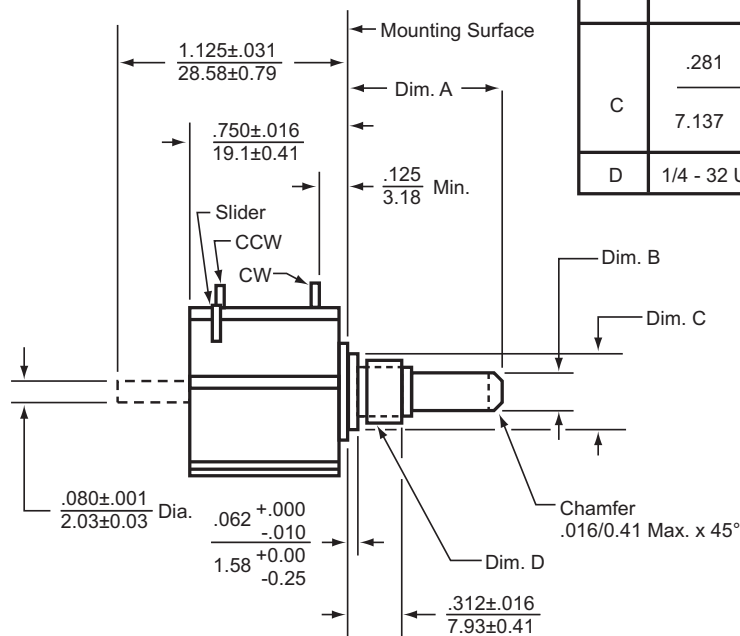

Dim.	7281	7284	7286 & 7288
A	$\frac{.688 \pm .031}{17.475 \pm 0.787}$	$\frac{.812 \pm .031}{20.625 \pm 0.787}$	$\frac{.812 \pm .031}{20.625 \pm 0.787}$
B	$\frac{.1248}{3.1699} \begin{matrix} +0.0000 \\ -0.0003 \end{matrix}$ Dia. $\frac{+0.0000}{-0.0076}$	$\frac{.2362}{6.0000} \begin{matrix} +0.0000 \\ -0.0005 \end{matrix}$ Dia. $\frac{+0.0000}{-0.0127}$	$\frac{.2500}{6.3500} \begin{matrix} +0.0000 \\ -0.0005 \end{matrix}$ Dia. $\frac{+0.0000}{-0.0127}$
C	$\frac{.281}{7.137} \begin{matrix} +0.000 \\ -0.002 \end{matrix}$ Dia. $\frac{+0.000}{-0.051}$	$\frac{.406}{10.312} \begin{matrix} +0.000 \\ -0.002 \end{matrix}$ Dia. $\frac{+0.000}{-0.051}$	$\frac{.406}{10.312} \begin{matrix} +0.000 \\ -0.002 \end{matrix}$ Dia. $\frac{+0.000}{-0.051}$
D	1/4 - 32 UNEF Thread	3/8 - 32 UNEF Thread	3/8 - 32 UNEF Thread

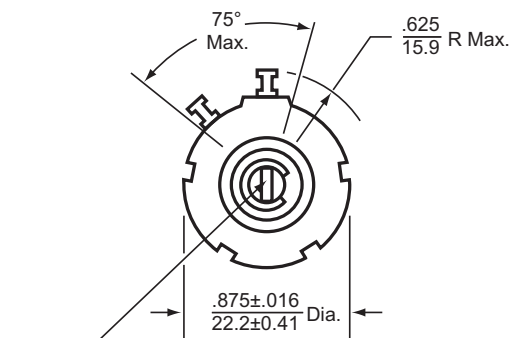

Optional Terminal Configuration

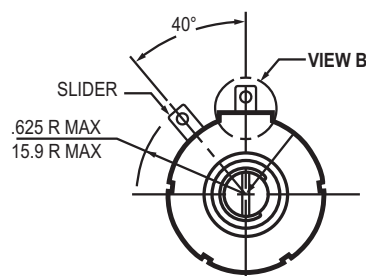

Use Special Feature Code "FT" to order.

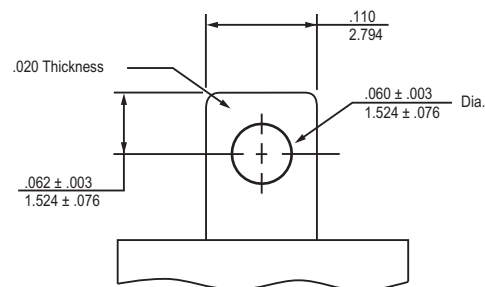

Enlarged View B

BI Technologies Corporation

4200 Bonita Place, Fullerton, CA 92835 USA

Phone: 714 447 2345 Website: www.bitechnologies.com

October 2, 2012

Model 7280 page 3 of 4

Model 7280

OUTLINE DRAWINGS (continued)

Model 7283 Servo Mount with Ball Bearing

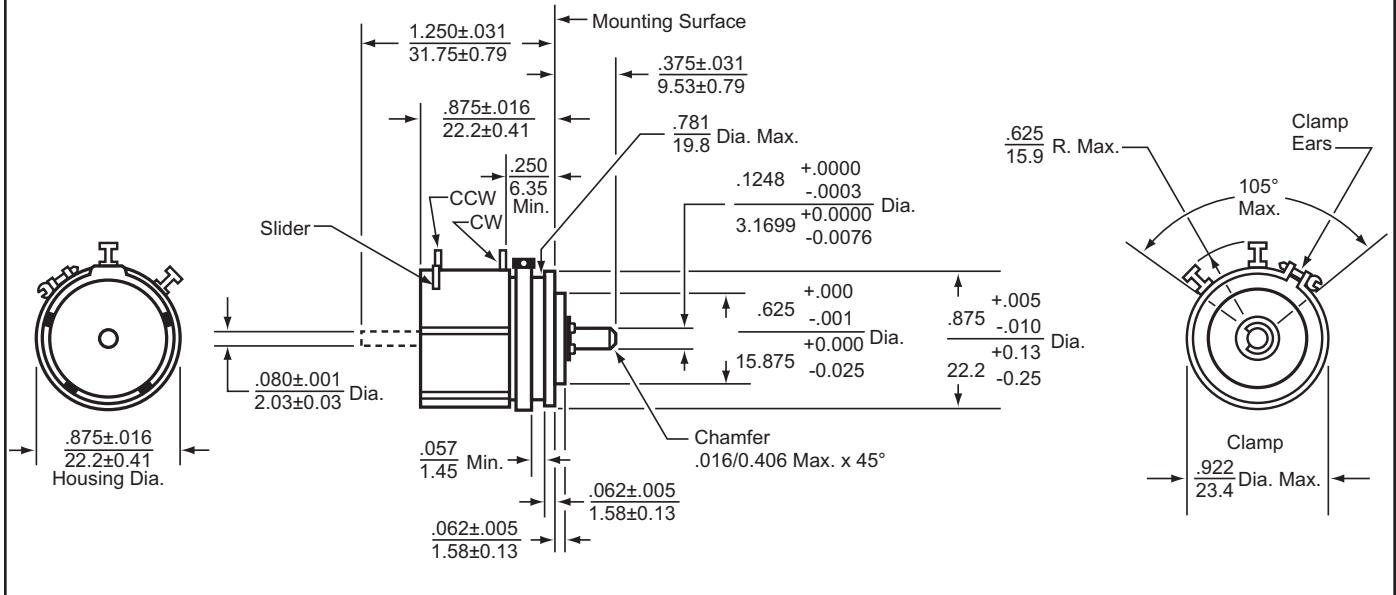

Optional Terminal Configuration

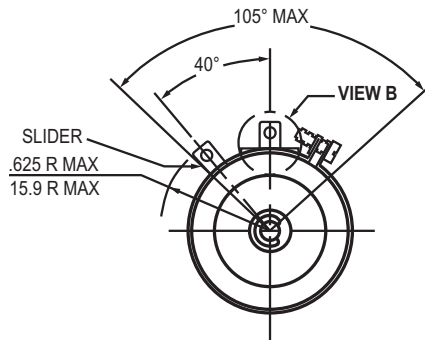

Use Special Feature Code "FT" to order.

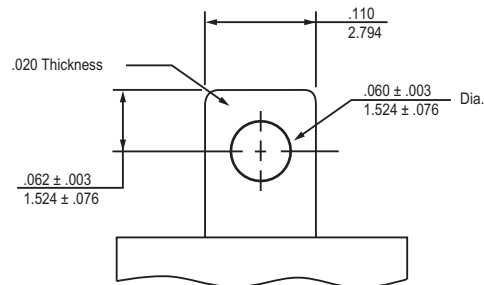

Enlarged View B