

# Model 8140 Series

## 7/8" Diameter

## 10 Turn\* Hybrid

## Precision Potentiometer / Position Sensor



### MODEL STYLES AVAILABLE

8141	1/8" Shaft, 1/4" Bushing
8143	1/8" Shaft, Servo
8144	6 mm Shaft, 3/8" Bushing
8146	1/4" Shaft, 3/8" Bushing
8148 (for heavy side load applications)	1/4" Shaft, 3/8" Bushing

### ELECTRICAL<sup>1</sup>

Resistance Range	1K to 100K ohms
Standard Resistance Tolerance	±10%
Minimum Practical Resistance Tolerance	±10%
Independent Linearity <sup>2</sup>	±0.25%
Minimum Practical Independent Linearity	±0.15%
Power Rating	2.0 Watts at 70°C, derating to 0 at 125°C
Dielectric Strength	1,000 V rms
Insulation Resistance	1,000 Megohms minimum
Output Smoothness	0.05% maximum ≤ 5 Kohms, 0.03% maximum above 5 Kohms
Actual Electrical Travel	3600° nominal
End Voltage	maximum 0.2% of input voltage
Tap Tolerance (voltage tap only)	± 0.05% of input voltage
Resolution	essentially infinite
Temperature Coefficient of Resistance	± 50 ppm/°C typical
Temperature Coefficient of Output Voltage <sup>3</sup>	±10 ppm/°C typical

### MECHANICAL

Total Mechanical Travel	3600° +15° -0°
Number of Gangs	2 maximum
Weight (single gang)	0.75 oz. nominal
Backlash	1° maximum
	<b>8141, 8144, 8146, 8148</b>
	<b>8143</b>
Static Stop Strength	maximum 60 oz.-in. 36 oz.-in.
Panel Nut Tightening Torque	maximum 25 lb.-in. n/a
Shaft End Play	maximum 0.010" 0.005"
Shaft Runout	maximum T.I.R. 0.003" 0.002"
Pilot Diameter Runout	maximum T.I.R. 0.004" 0.002"
Lateral Runout	maximum T.I.R. 0.005" 0.004"
Shaft Radial Play	maximum 0.003" 0.002"
Start/Run Torque (per gang)	maximum 0.8 oz.-in. 0.6 oz.-in.

<sup>1</sup> Specifications subject to change without notice.

<sup>2</sup> Linearity is measured between 1% and 99% of input voltage.

<sup>3</sup> Measured with 10 VDC CW to CCW and slider at 50% of electrical travel.

\* Model available in 3 & 5 turn versions.

**BI Technologies Corporation**

4200 Bonita Place, Fullerton, CA 92835 USA

Phone: 714 447 2345 Website: [www.bitechnologies.com](http://www.bitechnologies.com)

September 18, 2012

Model 8140 page 1 of 4

# Model 8140 series

## ENVIRONMENTAL (MIL-PRF-39023)

Operating Temperature Range	-40°C to +125°C dynamic, -55°C to +125°C static
Temperature Cycling	5 cycles, -40°C to +125°C, maximum 5% ΔR
Shock	6 ms Saw-tooth, 100 G's, 0.1 ms maximum discontinuity
Vibration	15 G's, 10 to 2,000 Hz, maximum 5% ΔR, 0.1 ms maximum discontinuity
Moisture Resistance	Five 24 hour cycles, maximum 5% ΔR
High Temperature Exposure	1,000 hours at 125°C, maximum 5% ΔR
Rotational Load Life (1 lb side load for 8148)	5 million shaft revolutions + 900 hours at 2.0 Watts & 70°C, maximum 5% ΔR

## ORDERING INFORMATION

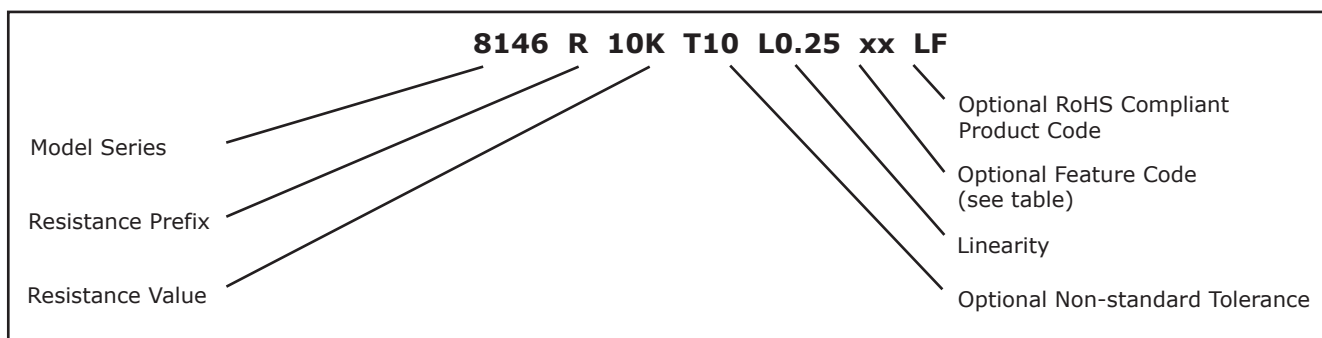

## FEATURE CODES

Center Tap	CT
Linearity Tape	LT
Flatted Shaft	FS
Slotted Shaft (standard on single gang 8146 without RS feature)	SS
Rear Shaft Extension (8143, 8146 single cup only)	RS
Shaft Lock (8141, 8146 only)	SL
High Torque 2-6 oz.-in. (8146 only)	HT
Additional Gang	2G
Gold Plated Solder Lug Terminals (see optional terminal configuration)	FT

When multiple Feature codes are used the P/N shall be in the same sequence as listed in this table (top to bottom).

## CIRCUIT DIAGRAM

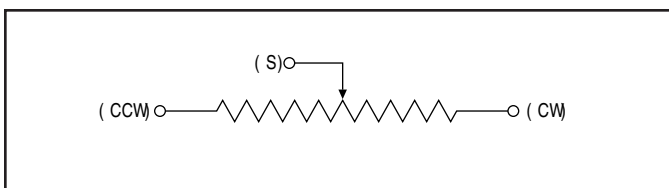

## STANDARD RESISTANCE VALUES

1K	2K	5K	10K	20K	50K	100K
----	----	----	-----	-----	-----	------

# Model 8140 series

## MATCHING TURNS COUNTING DIALS

**8141: RBJ, 2601, 2641**  
**8146: 2606, 2607, 2626, 2627, 2646, 2126, 2606S, 2607S, 2646S, 2647S, RB**

## OUTLINE DRAWINGS

### Models 8141 & 8146 Bushing Mount with Sleeve Bearing

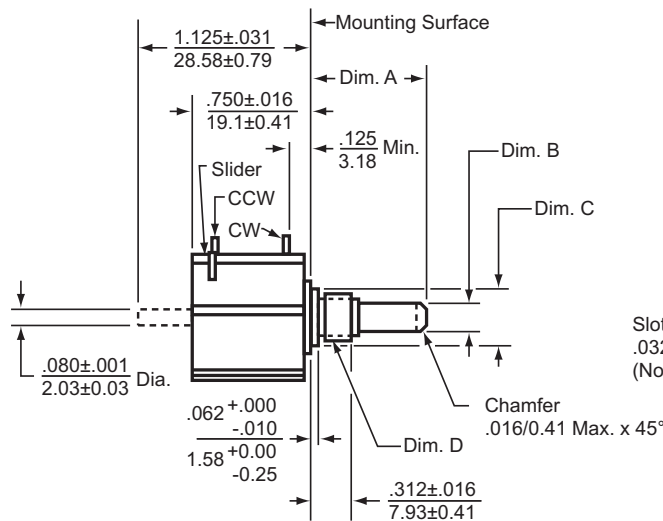

Dim.	8141	8146
A	$\frac{.688 \pm .031}{17.475 \pm 0.787}$	$\frac{.812 \pm .031}{20.625 \pm 0.787}$
B	$\frac{.1248 \pm .0000}{3.1699 \pm 0.0000}$ Dia. $\frac{-.0003}{-0.0076}$	$\frac{.2500 \pm .0000}{6.3500 \pm 0.0000}$ Dia. $\frac{-.0005}{-0.0127}$
C	$\frac{.281 \pm .000}{7.137 \pm 0.000}$ Dia. $\frac{-.002}{-0.051}$	$\frac{.406 \pm .000}{10.312 \pm 0.000}$ Dia. $\frac{-.002}{-0.051}$
D	1/4-32 UNEF Thread	3/8-32 UNEF Thread

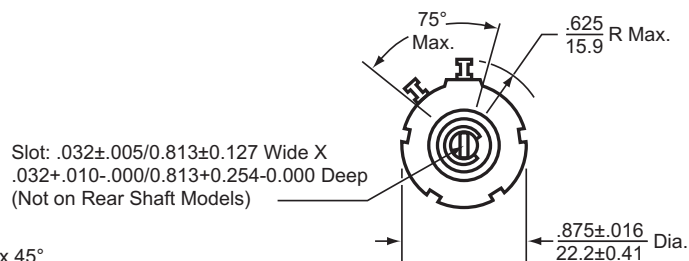

### Optional Terminal Configuration

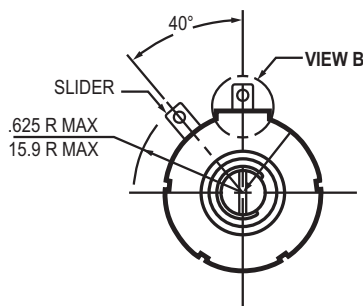

Use Special Feature Code "FT" to order.

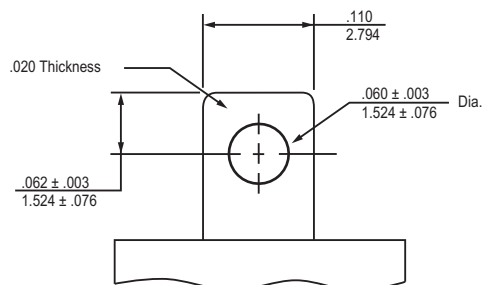

Enlarged View B

# Model 8140 series

## OUTLINE DRAWINGS (continued)

### Model 8143 Servo Mount with Ball Bearing

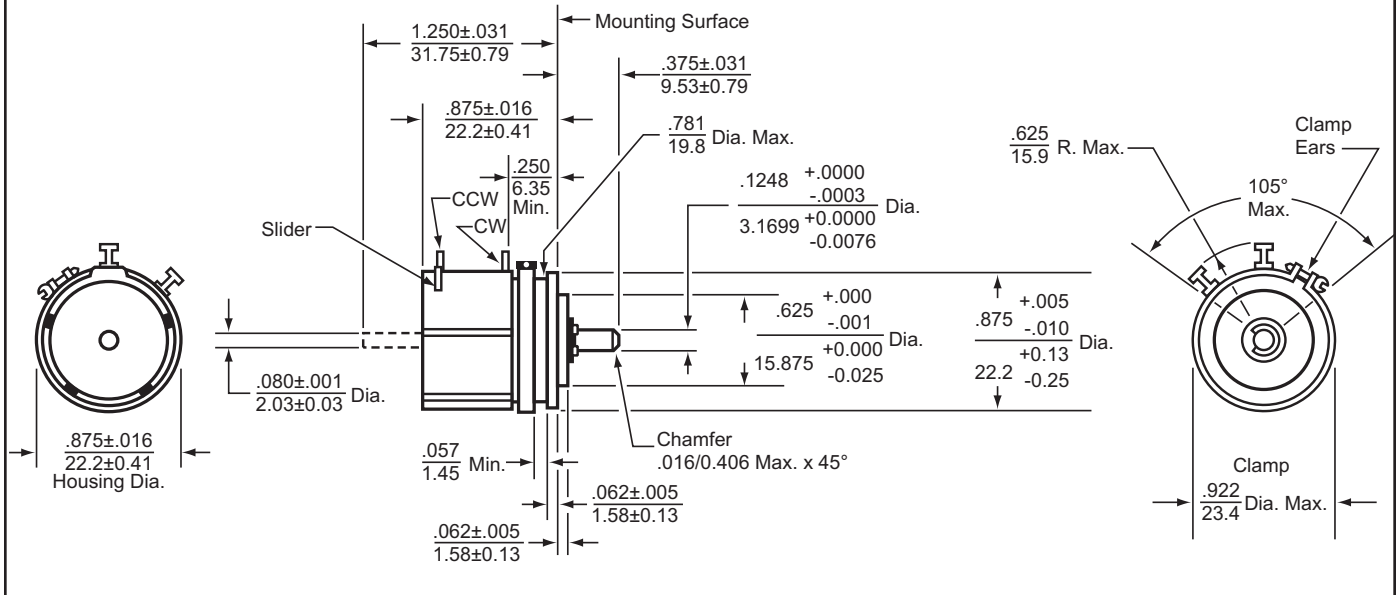

### Optional Terminal Configuration

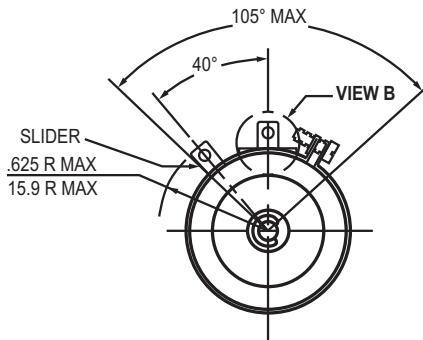

Use Special Feature Code "FT" to order.

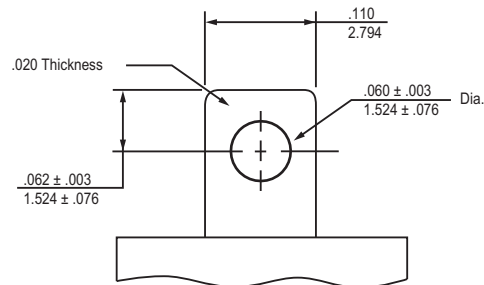

Enlarged View B