

MODEL 82 SW

1/4" Diameter Sealed Switch

NEW PRODUCT



ELECTRICAL

| | |
|--------------------------------|--|
| Input Voltage, Maximum | 16 Vdc |
| Slider Current, Maximum | 100mA or within rated power, whichever is less |
| Insulation Resistance, Minimum | 10 Megohms |
| Contact Resistance, Maximum | 2 Ohms |
| Contact Timing | Non-shorting |
| Switch Type | Single Pole / Double Throw (SPDT) |

ENVIRONMENTAL

| | |
|-----------------------------|-----------------------------|
| Seal | 85°C Fluorinert® (No Leaks) |
| Operating Temperature Range | -55°C to +125°C |
| Thermal Shock | 5 cycles, -55°C to +125°C |
| Moisture Resistance | Ten 24 hour cycles |
| Shock, 6ms Sawtooth | 100G's |
| Vibration | 20G's, 10 to 2,000 Hz |
| Rotational Life | 200 cycles |
| Resistance to Solder Heat | 260°C for 10 sec. |

MECHANICAL

| | |
|--------------------------|-----------------------|
| Stop Strength | 5 oz.-in. |
| Torque, Starting Maximum | 3 oz.-in. (0.021 N-m) |
| Weight, Nominal | .02 oz. (0.60 grams) |

Fluorinert® is a registered trademark of 3M Company.
Specifications subject to change without notice.
Last Update: 06/24/02.

TOP ADJUSTMENT (Inch/mm)

Model 82PSW, 82PFSW

| Model | Dim. A |
|--------|----------------------------|
| 82PSW | $\frac{.25}{6.35}$ Min. |
| 82PFSW | $\frac{.625}{15.875}$ Min. |

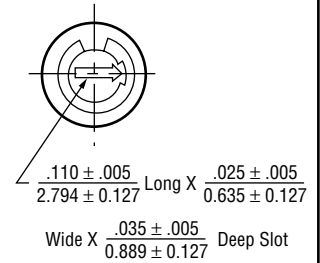
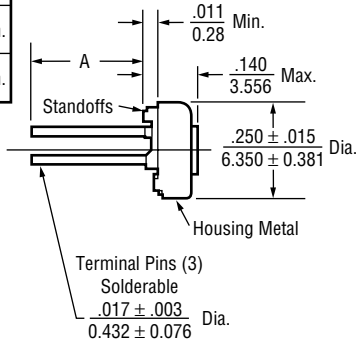
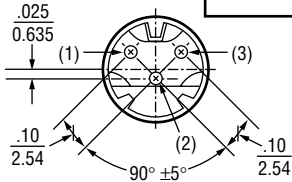

Note: Model 82PSW dimensions applicable to all models except as noted.

Model 82MSW

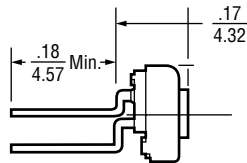
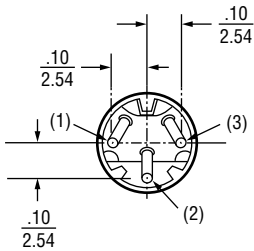

Model 82WSW

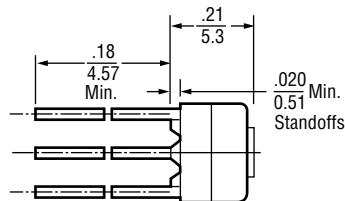
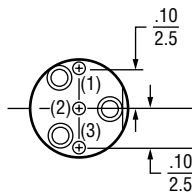

SIDE ADJUSTMENT (Inch/mm)

Model 82PASW

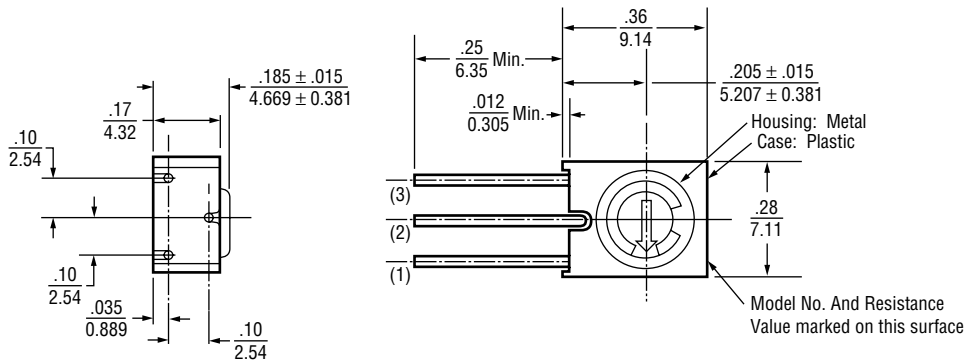

PACKAGING

Standard: Boxes

| | | |
|----------|---|------------------------------|
| Capacity | = | 50 Units (82PASW, 82PFSW) |
| | = | 100 Units (All other styles) |

Option: Tubes

All units oriented with #1 pin to same side.

| | Pin Style | PASW | PSW,MSW,WSW |
|----------|-----------|------------|-------------|
| Magazine | Width | = 0.28" | 0.34" |
| | Height | = 0.94" | 0.65" |
| | Length | = 15.6" | 27.5" |
| | Capacity | = 50 Units | 100 Units |

Option: Tape & Reel, Ammo Pack (Available for 82WSW Only)

All units oriented with #1 pin to the right of the direction of feed.

| | | | |
|------|---|---|--------------------------|
| | Seat Plane to Centerline of Sprocket Hole | = | .71" (18.03 mm) |
| Tape | Width | = | 18 mm |
| | Sprocket | = | Single Hole .50" spacing |
| | Capacity | = | 1,000 Units |
| Reel | Diameter | = | 14" (356 mm) |
| Ammo | Tape Fold | = | 12" (305 mm) |
| | Box | = | 1.5" x 13" x 10" |

ORDERING INFORMATION

Standard:

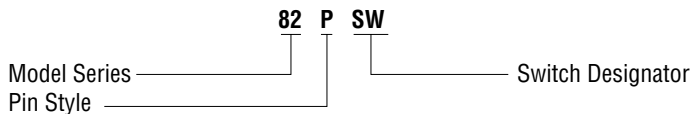

Option:

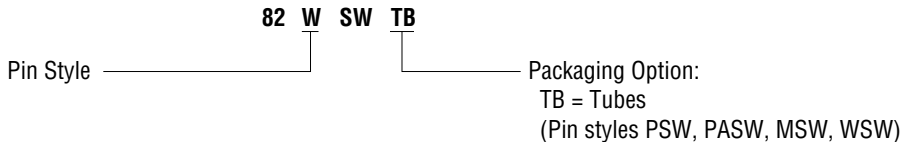

Option:

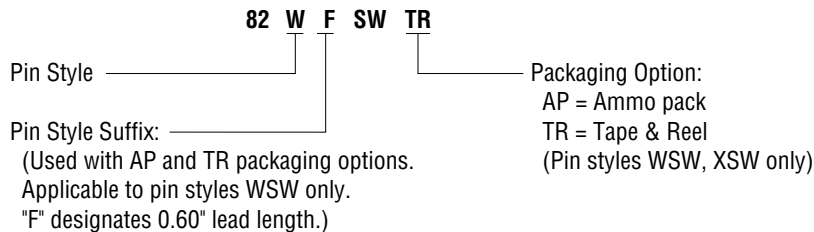

CIRCUIT DIAGRAM

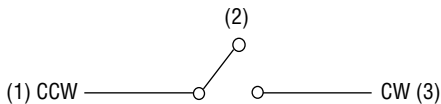

NOTES

Metric equivalents, based on 1 inch = 25.4mm are rounded to the same number of significant figures as in the original English units and are provided for general information only.

Tolerances unless otherwise specified:
Linear = $\pm .01$ inches (.25mm)
Angular = ± 2 degrees

