

# Single-chip Type with Built-in FET Switching Regulators

## Simple Step-down Switching Regulators with Built-in Power MOSFET



### BD9G101G

#### ● General Description

The BD9G101G is switching regulator with integrated internal high-side 42V Power MOSFET. It provides 0.5A DC output with small SOT23 package.

Operating frequency is fixed 1.5MHz, allowing the use of small inductor and ceramic capacitor. Phase compensation components is built in. The BD9G101G is available in SOT-23-6(SSOP6) package.

#### ● Features

- High and Wide Input Range (VCC=6V~42V)
- 45V/800mΩ Internal Power MOSFET
- 1.5MHz Fixed Operating Frequency
- Feedback Pin Voltage 0.75V±1.5%
- Internal compensated
- Internal Over Current protection, Under Voltage Locked Out, Thermal shutdown
- 0μA Shutdown Supply Current
- 6-Lead SOT-23 package(SSOP6)

#### ● Key Specifications

■ Input Voltage	6~42 [V]
■ Ref. Precision (Ta=25°C)	±1.5[%]
(Ta=-25~105°C)	±2.0[%]
■ Max Output Current	0.5 [A] (Max.)
■ Operating Temperature	-40°C~105°C
■ Max Junction Temperature	150°C

#### ● Packages

SSOP6

2.90 mm × 2.80 mm × 1.25 mm



SSOP6

#### ● Applications

- Industrial distributed power applications
- Automotive Applications
- Battery powered equipment
- OA instruments

#### ● Typical Application Circuits

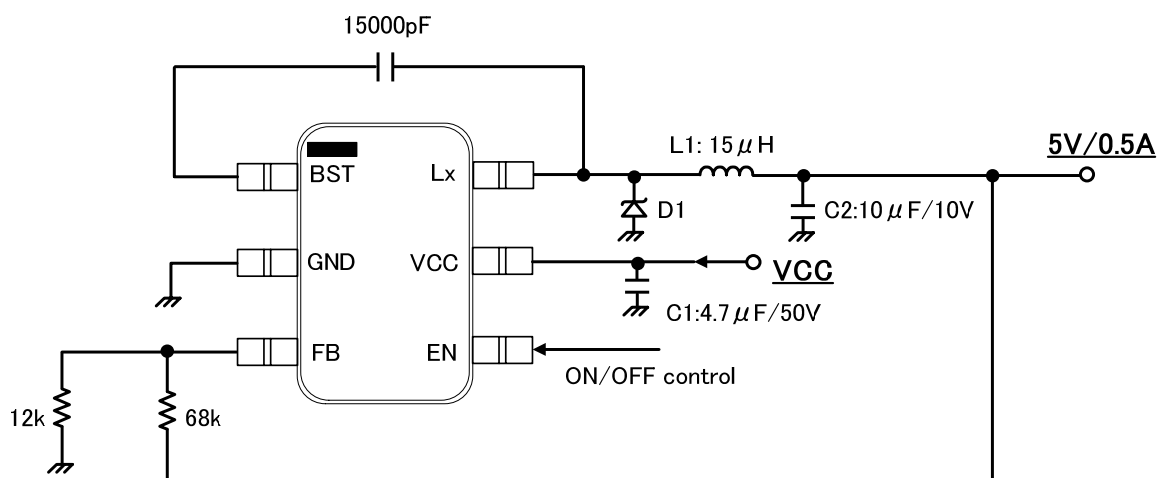

Figure 1. Typical Application Circuit

○Structure : Silicon Monolithic Integrated Circuit ○This product is not designed for normal operation with in a radioactive.

● Pin Configuration

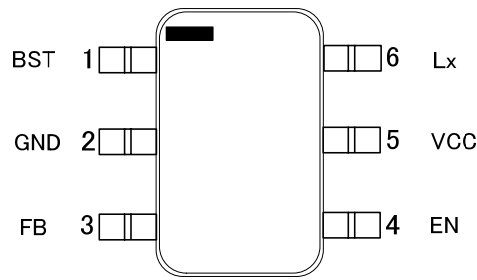

Figure 2. Pin Configuration (TOP VIEW)

● Pin Description

Pin No.	Pin Name	Description
1	BST	The pin is power supply for floating Power NMOS driver. Connected a bypass capacitor between the pin and Lx pin for bootstrap operation.
2	GND	Ground. It should be connected as possible to the output capacitor ground avoiding the high current switch paths.
3	FB	Voltage feedback pin. This pin is error-amp input, the DCDC is set 0.75V at this pin with feed-back operation.
4	EN	Enable input pin. The DCDC is start-up to apply over 2.0V. This pin is pull-down about 550kΩ, the DCDC is shutdown to open or apply under 0.8V.
5	VCC	Input supply. It should be connected as near as possible to the bypass capacitor.
6	Lx	Power FET switch output. It should be connected as near as possible to the schottky barrier diode, and inductor.

● Block Diagram

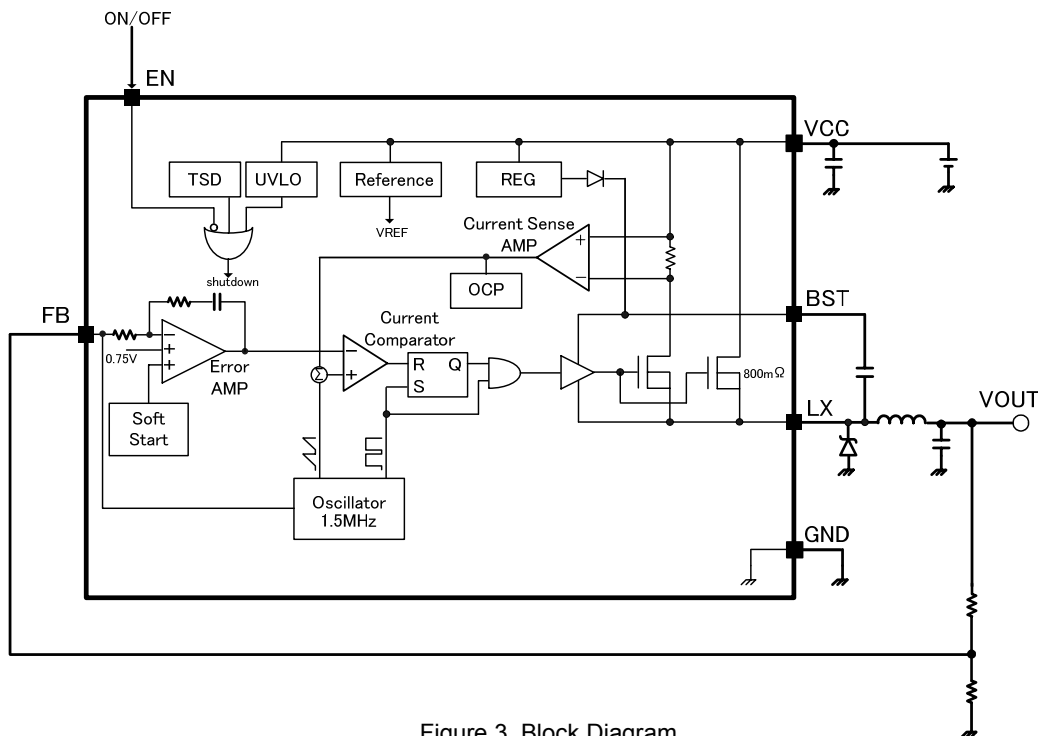

Figure 3. Block Diagram

**●Description of Blocks**

1. Reference  
This block generates reference voltage and current. It start operation by applying EN more than 2.0V.  
It provides reference voltage and current to error-amp , oscillator ,and etc.
2. REG  
This is a gate drive voltage generator and 4.2V regulator for internal circuit power supply.
3. OSC  
This is a precise wave oscillation circuit with operation frequency fixed to 1.5MHz fixed.  
To protect from output shorted to GND, Frequency fold-back function is built in.
4. Soft Start  
This block does Soft Start to the output voltage of DC/DC comparator, and prevents in-rush current during Start-up.  
Soft Start Time depend on application and start-condition because Frequency fold-back function is built in.
5. ERROR AMP  
This is an error amplifier what detects output signal, and outputs PWM control signal.  
Internal reference voltage is set to 0.75V. Also, the BD9G101G has internal phase compensated element between input and output.
6. ICOMP  
This is a comparator that outputs PWM signal from current feed-back signal and error-amp output for current-mode.
7. Nch FET SW  
This is an 45V/800mΩ Power Nch MOSFET SW that converts inductor current of DC/DC converter.
8. UVLO  
This is a low voltage error prevention circuit.  
This prevents internal circuit error during increase of power supply voltage and during decline of power supply voltage.  
It monitors VCC pin voltage and internal REG voltage, And when VCC voltage becomes 5.4V and below, it turns OFF all output FET and turns OFF DC/DC comparator output, and Soft Start circuit resets.  
Now this Threshold has hysteresis of 200mV.
9. EN  
When a Voltage of 2.0V or more is applied, it turns ON, at Open or 0V application, it turns OFF.  
About 550kΩ Pull-down Resistance is contained within the Pin.
10. OCP  
The current of power MOSFET is limited by this function.  
The power MOSFET current is sensed by current sense FET. If the current of power MOSFET is over 1.2A(typ), this function reduce duty by pulse –by- pulse and restrict the and restraint on over current.
- 11.TSD  
Circuit for preventing malfunction at high Temperature .  
When it detects an abnormal temperature exceeding  $T_j=175^{\circ}\text{C}$ , it turns OFF DC/DC Comparator Output. The threshold of TSD has Hysteresis( $25^{\circ}\text{C}$ ). If Temperature falls  $150^{\circ}\text{C}$ ,the IC automatically returns.

### ●Absolute Maximum Ratings

Item	Symbol	Ratings	Unit
VCC	VCC	45	V
Maximum input current	I <sub>max</sub>	1.0	A
BST to GND	VBST	50	V
BST to Lx	ΔVBST	7	V
EN	VEN	45	V
Lx	VLx	45	V
FB	VFB	7	V
Power Dissipation	P <sub>d</sub>	0.675 <sup>(*)1</sup>	W
Operating Temperature	T <sub>opr</sub>	-40~+105 <sup>(*)2</sup>	°C
Storage Temperature	T <sub>stg</sub>	-55~+150	°C
Junction Temperature	T <sub>jmax</sub>	150	°C

(\*1)During mounting of 70×70×1.6t mm 1layer board.Reduce by 5.4mW for every 1°C increase. (Above 25°C)

(\*2)Exceeding the maximum allowable power dissipation will cause excessive die temperature, and the regulator will go into thermal shutdown. Internal thermal shutdown circuitry protects the device from permanent damage. thermal shutdown engages at T<sub>j</sub>=175°C(typ) and disengages at T<sub>j</sub>=155°C (typ)

### ●Electrical Characteristics (Unless otherwise specified Ta=25°C, VCC=24V, Vo=5V,EN=3V )

Parameter	Symbol	Limit			Unit	Condition
		Min	Typ	Max		
<b>【Circuit Current】</b>						
Stand-by Current	I <sub>st</sub>	—	0	5	μA	VEN=0V
Operating Current	I <sub>cc</sub>	—	0.7	1.2	mA	FB=1.2V
<b>【Under Voltage Lock Out (UVLO)】</b>						
Threshold Voltage	V <sub>uv</sub>	5.1	5.4	5.7	V	
Hysteresis width	V <sub>uvhy</sub>	—	200	300	mV	
<b>【Oscillator】</b>						
Switching Frequency	f <sub>osc</sub>	1.3	1.5	1.7	MHz	
Max Duty Cycle	D <sub>max</sub>	85	-	-	%	
<b>【Error AMP】</b>						
FB Pin Reference Voltage	VFBN	0.739	0.750	0.761	V	Ta=25°C
	VFBA	0.735	0.750	0.765	V	Ta=-25~105°C
FB Pin Bias Current	IFB	-100	0	100	nA	VFB=2.0V
Soft-Start Time	T <sub>soft</sub>	1.2	4.0	-	ms	
<b>【Current Comparator】</b>						
Trans-conductance	G <sub>cs</sub>	-	3	-	A/V	
<b>【Output】</b>						
Nch MOSFET ON Resistance	R <sub>onH</sub>	—	800	—	mΩ	
Min ON Time	T <sub>min</sub>	—	100	—	nsec	
Switch Current Limit	I <sub>ocp</sub>	0.85	1.2	—	A	
<b>【CTL】</b>						
EN Threshold Voltage	ON	VENON	2.0	—	VCC	V
	OFF	VENOFF	-0.3	—	0.8	V
EN Input Bias Current	REN	2.7	5.5	11	μA	VEN=3V

ⓂNot designed to withstand radiation.

●Operating Ratings

Item	Symbol	Ratings			Unit
		Min	Typ	Max	
Input Voltage	VCC	6	-	42	V
Output Voltage	VOUT	1.0 <sup>(*2)</sup>	-	VCC × 0.7 <sup>(*3)</sup>	V
Output Current	IOUT	-	-	500	mA

(\*2)Restricted by minimum on pulse typ. 100nsec  
 (\*3)Restricted by maxduty ,Ron and BST-UVLO.

●input and output voltage restriction

The input voltage range of BD9G101G is limited by Ron, Maxduty(min85%) and preventing malfunction at low voltage between BST and LX(BST-UVLO).

①BST-UVLO

BSTUVLO is the function that prevent the IC from abnormal operation that is caused by shortage of charge of High-SideFET driving. If the voltage between BST and Lx is lower than 1.5V, High-Side FET is turned off and there are new pass to charge voltage VCC to BST. BST voltage is charged by Vcc and goes over BST-UVLO threshold. As a result , BST-UVLO is turned off.

The condition that BST-UVLO is working property is  
 $VCC \gg (BST-UVLO \text{ threshold} + Vf) + Vout$ .

Therefore maximum output voltage is lower than  $Vin - 3V$ .

※If output voltage is higher than  $Vin - 3V$ , output voltage ripple is boosted by the trigger of BSTUVLO. This is no problem in IC operation.

②Max duty , Ron

Maximum output voltage is limited by maxduty(min85%) and FET Ron.

In the case of  $I_o=500mA$ , VCC drop down  $500mA \times 0.8\Omega = 0.6V$  besides maxduty.

$V_{omax} = (V_{cc} - R_{on} \times I_{omax}) \times 0.85$  (casually formula)

Considering the negative voltage in the case of pulling diode current, Formula of maximum output voltage is

$V_{omax} = VCC \times 0.7$ .

③minimum on pulse

Minimum output voltage is limited by minimum on pulse (typ 100nsec).

Output voltage = frequency(typ 1.5MHz) × FET on time × Vin

If output voltage is lower than this formula , Output ripple voltage is boosted by intermittent spring.

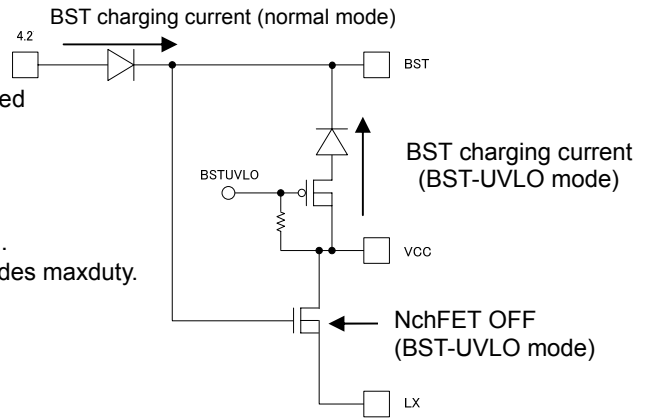

Figure 4. BST-UVLO image

### ●Frequency fold-back function

This IC has the frequency fold-back function to prevent from over current with the circuit output is shorted. The frequency fold-back has the function that the frequency is changed by FB voltage. Figure.5 shows FB voltage vs frequency Characteristics.

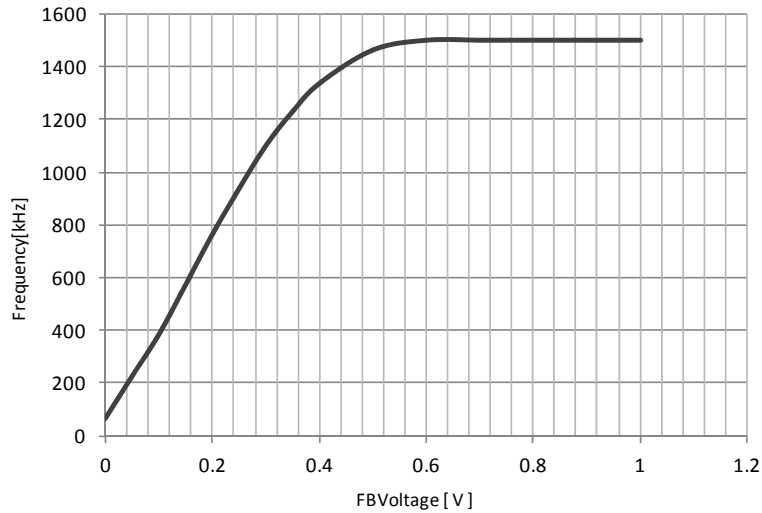

Figure 5. FB voltage -frequency Characteristics

When the output node is shorted, the IC narrows the frequency to 150kHz(typ) so that input current limiting. This IC operates on 1.5MHz in case of normal mode, the voltage of FB is about 0.75V.

### ●Start-up Characteristics

When the IC is starting up, frequency reacts to the voltage of FB on the function of frequency fold back. For the Softstart is operated by internal frequency clock, according to rising to the output voltage, the Softstart rising speed is more faster. Please check the using condition and the application waveform (P.10,P13) because of the Start-up characteristics changes to the output load and the output capacitor.

● Typical Performance Characteristics

(Unless otherwise specified,  $T_a=25^\circ\text{C}$ ,  $V_{CC}=12\text{V}$ ,  $V_o=5\text{V}$ ,  $EN=3\text{V}$ )

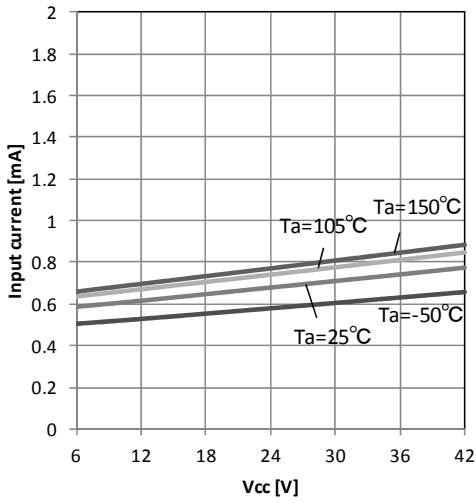

Figure 6. Operating Current - Input Voltage

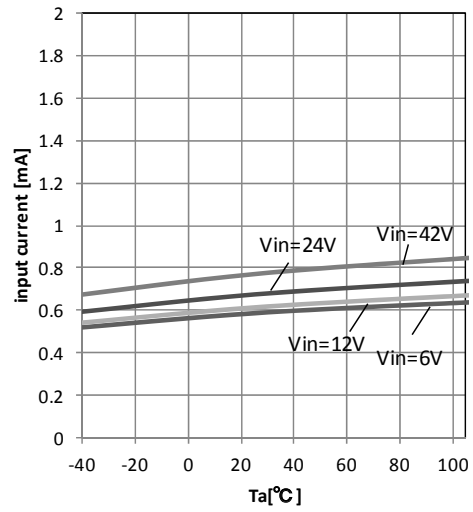

Figure 7. Operating Current - Temperature

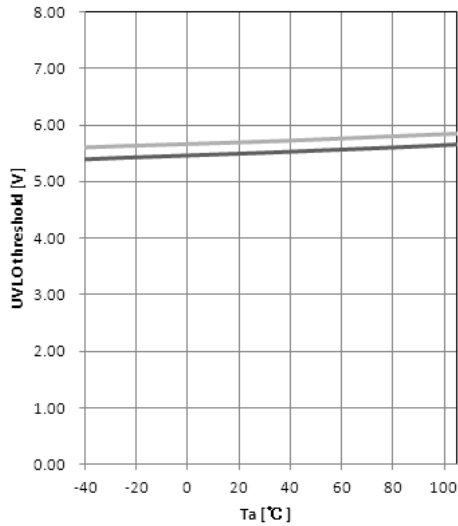

Figure 8. UVLO Threshold - Temperature

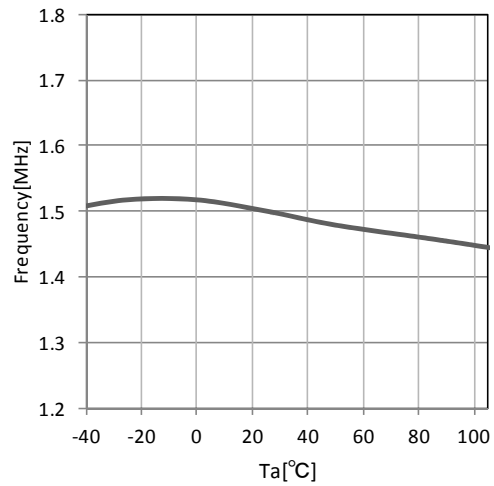

Figure 9. Oscillation frequency - Temperature

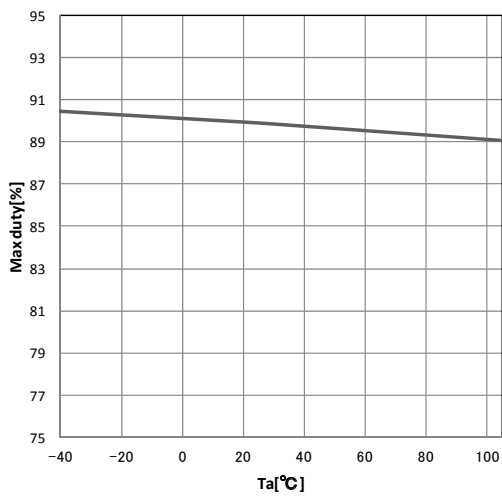

Figure 10. Max Duty - Temperature

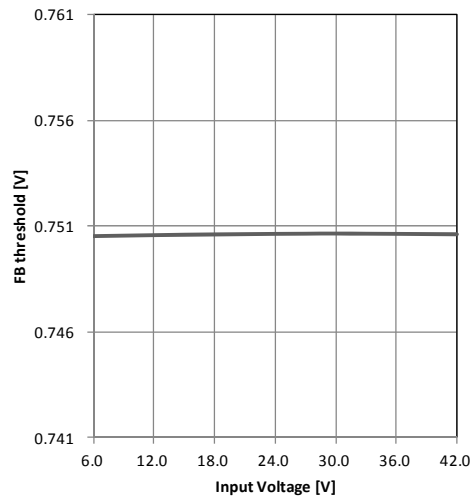

Figure 11. FB Pin Reference Voltage - Input Voltage

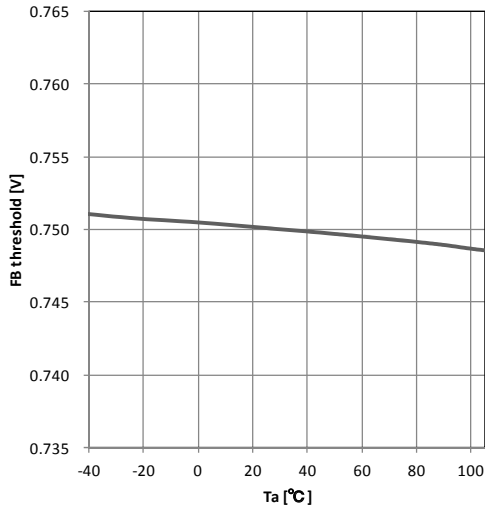

Figure 12. FB Threshold - Temperature

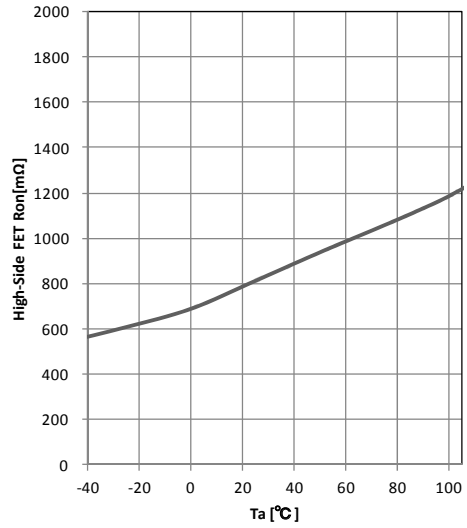

Figure 13. Nch MOSFET ON Resistance - Temperature

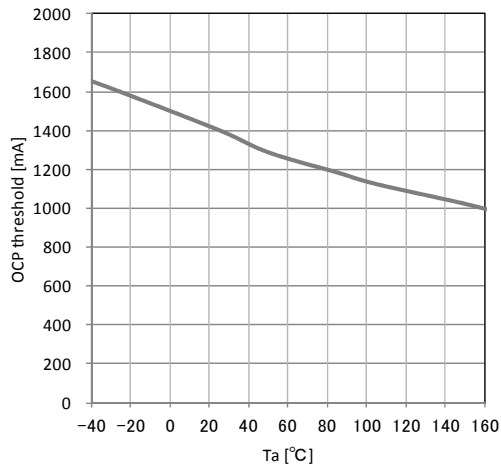

Figure 14. OCP threshold- Temperature

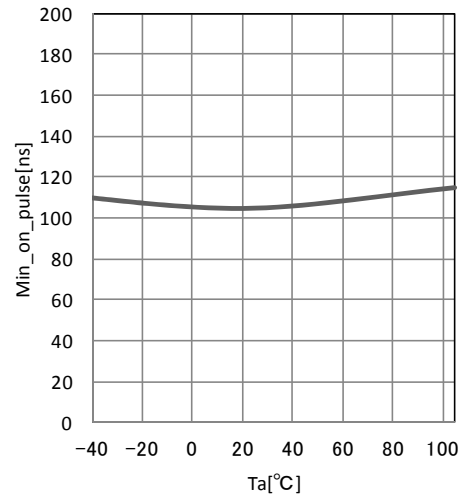

Figure 15. Min ON Time - Temperature

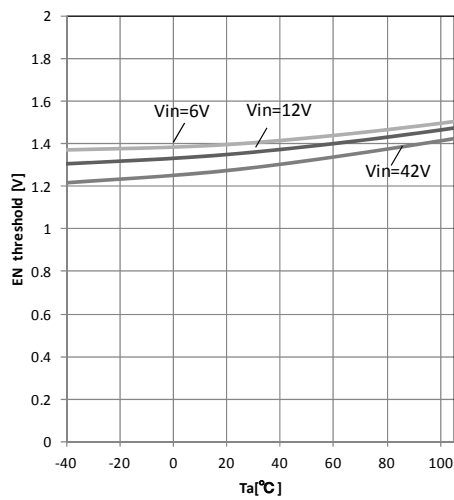

Figure 16. EN Threshold Voltage - Temperature



●Reference Characteristics of typical Application Circuits

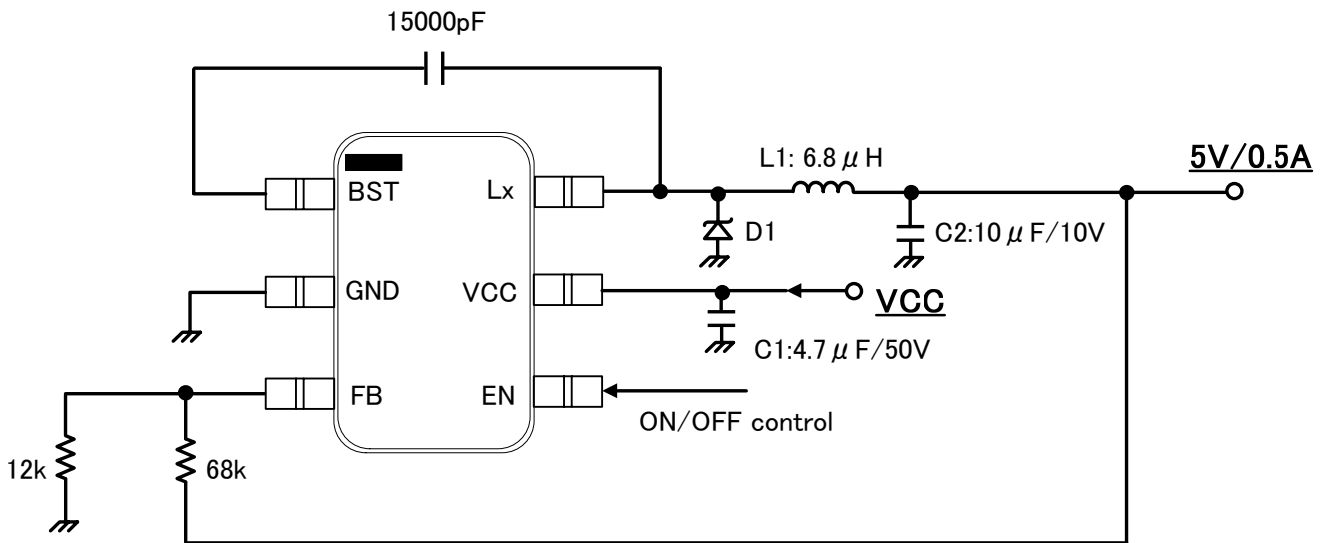

Figure 17. Typical Application Circuit (VOUT=5V)

Parts	L1 :	TOKO TAIYO YUDEN	DEM4518C 1235AS-H-100M NR4018	10μH 10μH
	C1 :	Murata	GRM32EB31H475KA87	4.7μF/50V
C2 :	Murata	GRM31CB11A106KA01		10μF/10V
D1 :	Rohm	RB060M-60		

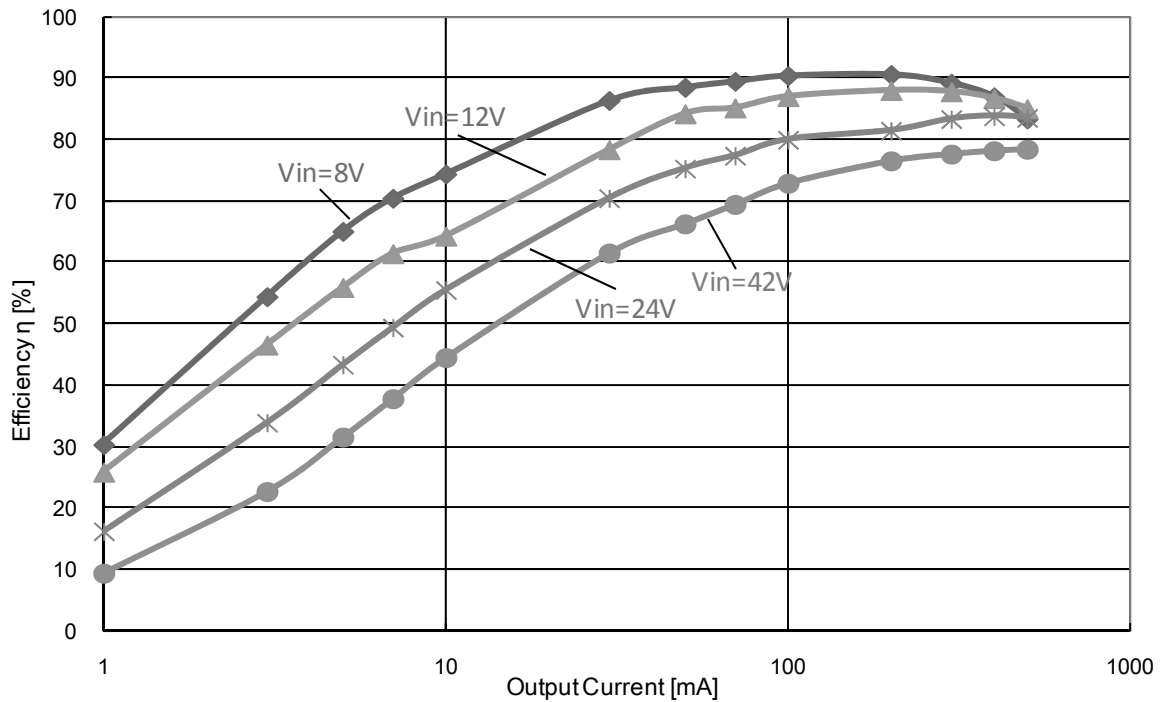

Figure 18. Efficiency - Output Current VOUT=5V

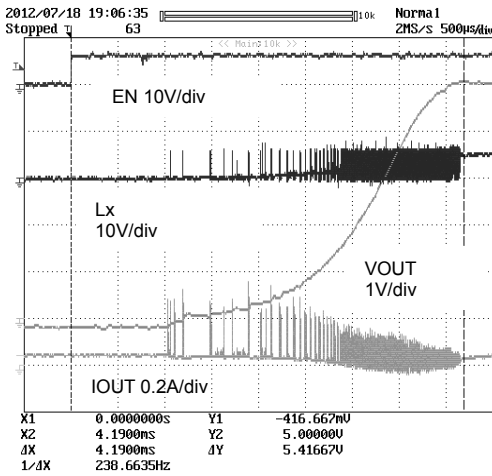

Figure 19. Start-up Characteristics  
VIN=8V, IOU=0mA, VOUT=5V

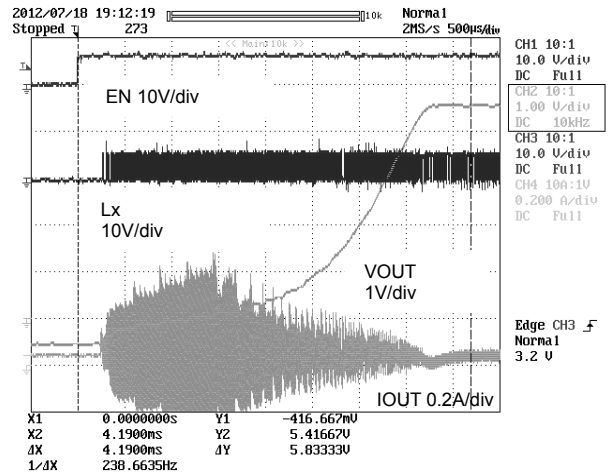

Figure 20. Start-up Characteristics  
VIN=8V, IOU=500mA, VOUT=5V

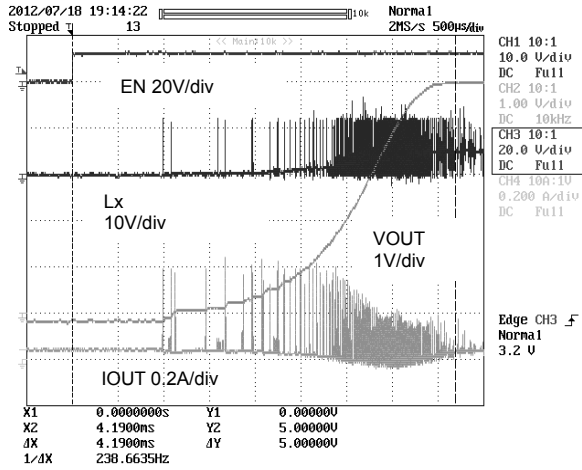

Figure 21. Start-up Characteristics  
VIN=12V, IOU=0mA, VOUT=5V

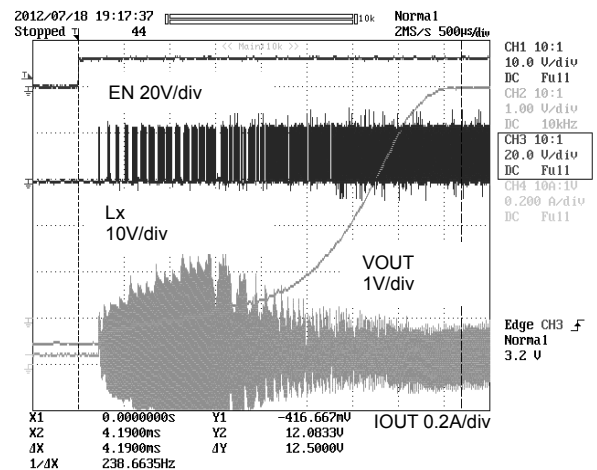

Figure 22. Start-up Characteristics  
VIN=12V, IOU=500mA, VOUT=5V

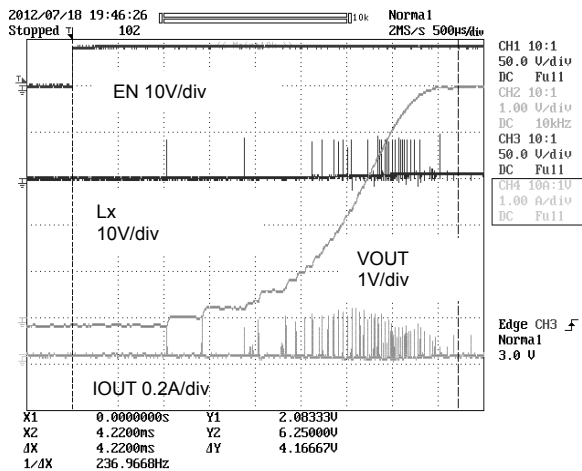

Figure 23. Start-up Characteristics  
VIN=42V, IOU=0mA, VOUT=5V

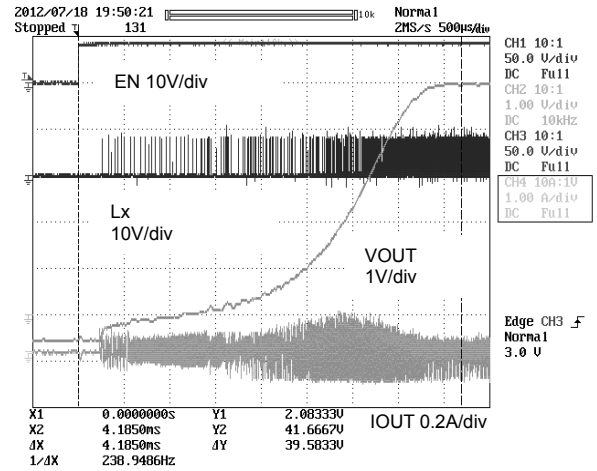

Figure 24. Start-up Characteristics  
VIN=42V, IOU=500mA, VOUT=5V

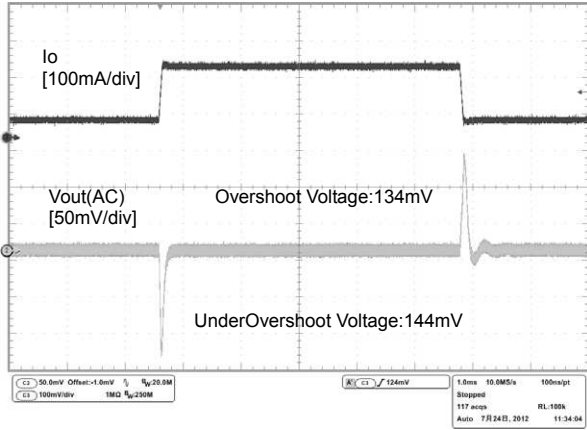

Figure 25. Load Response  
Io=50mA↔200mA

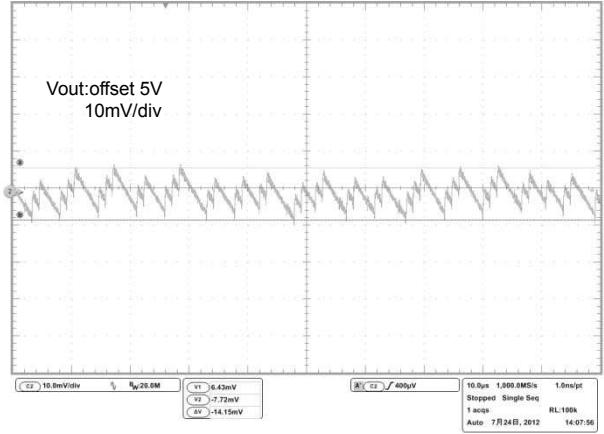

Figure 26. Lx Switching/ Vout Ripple  
Io = 20mA

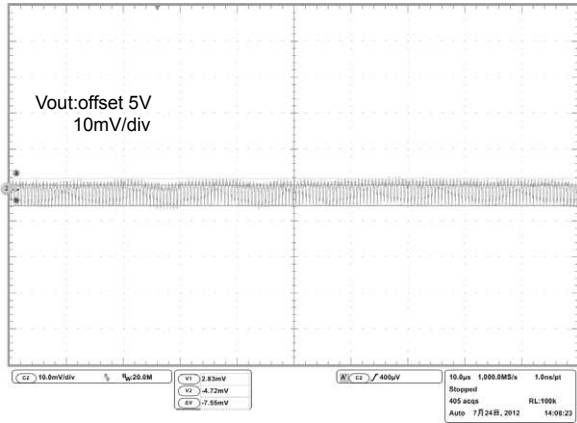

Figure 27. Lx Switching/ Vout Ripple  
Io=200mA

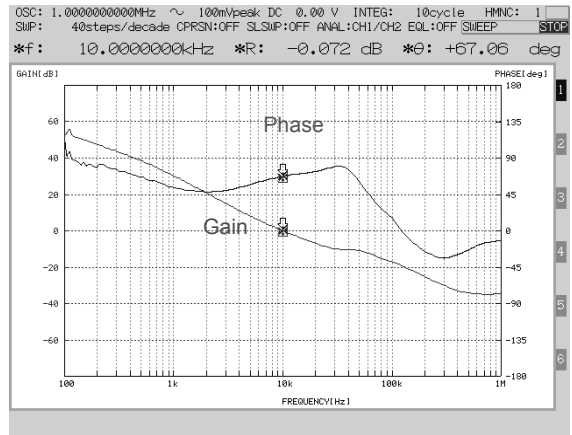

Figure 28. Frequency Response  
Io=100mA, VOUT=5V

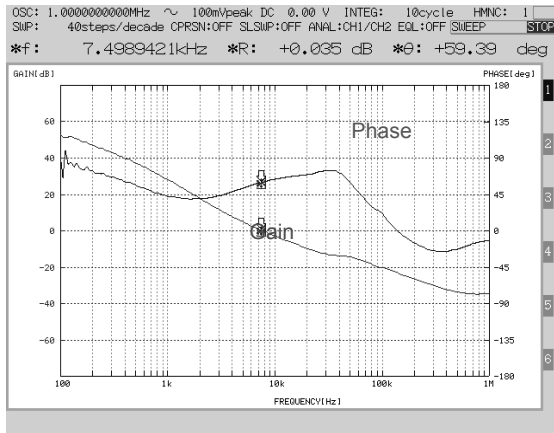

Figure 29. Frequency Response  
Io=500mA, VOUT=5V

●Reference Characteristics of typical Application Circuits

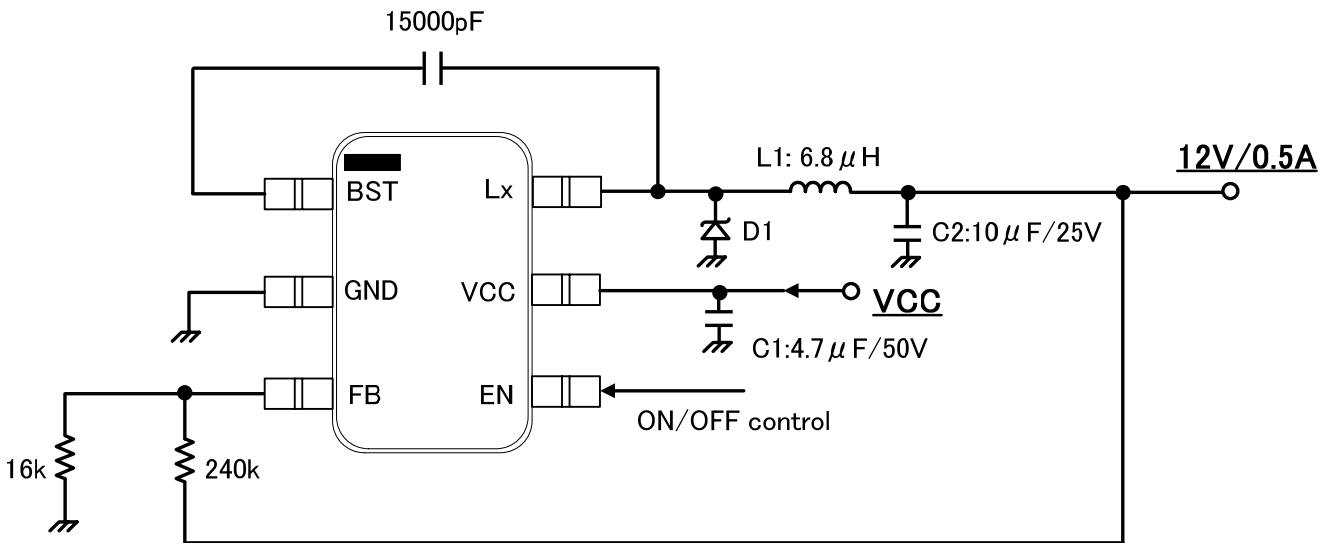
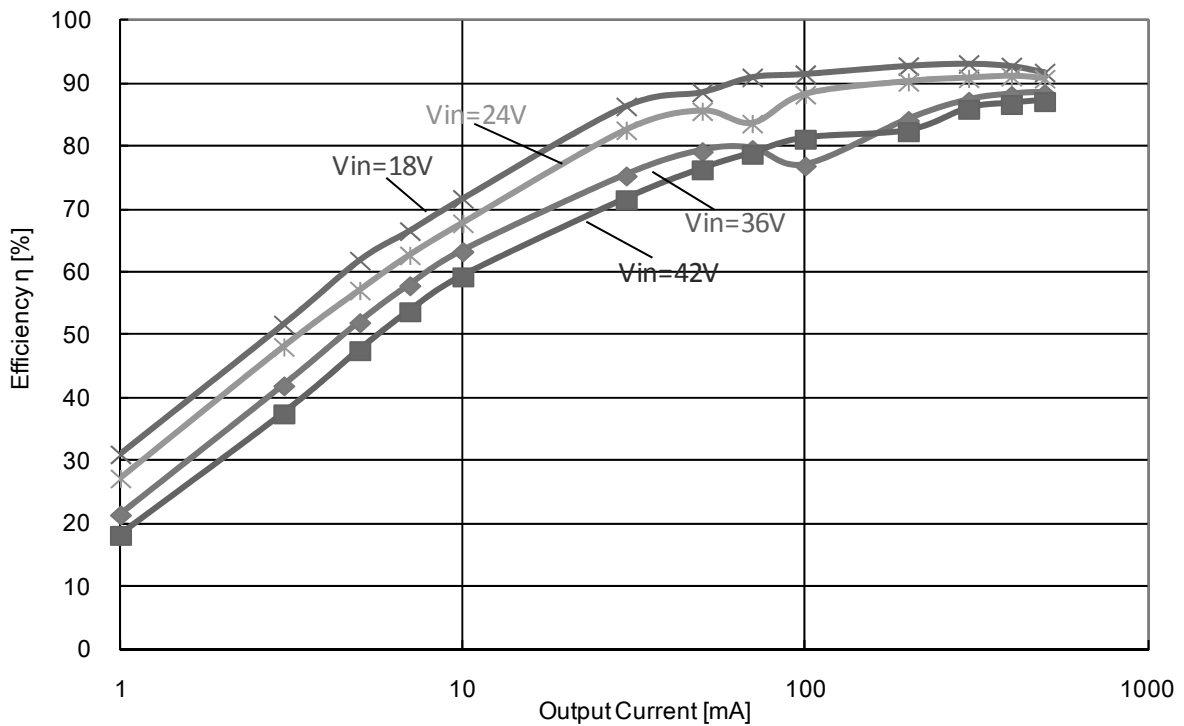

Figure 30. Typical Application Circuit (VOUT=12V)

使用部品	: L1	: TOKO TAIYO YUDEN	DEM4518C 1235AS-H-6R8M NR4018	6.8μH 6.8μH
	C1	: Murata	GRM32EB31H475KA87	4.7μF/50V
	C2	: Murata	GRM31CB11A106KA01	10μF/25V
	D1	: Rohm	RB060M-60	



\*The efficiency is fall when the switching waveform is turning from intermittent mode to continuous mode

Figure 31. Efficiency - Output Current VOUT=12V

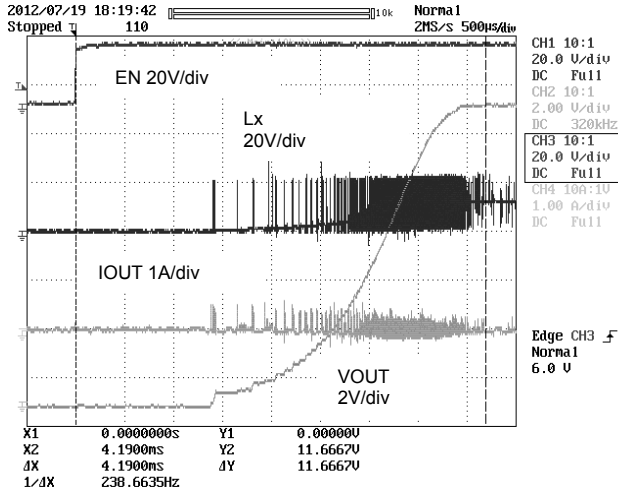

Figure 32. Start-up Characteristics  
VIN=18V, IOU=0mA, VOUT=12V

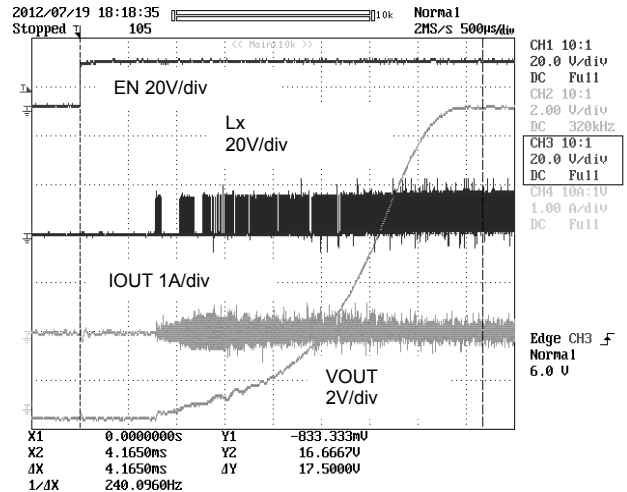

Figure 33. Start-up Characteristics  
VIN=18V, IOU=500mA, VOUT=12V

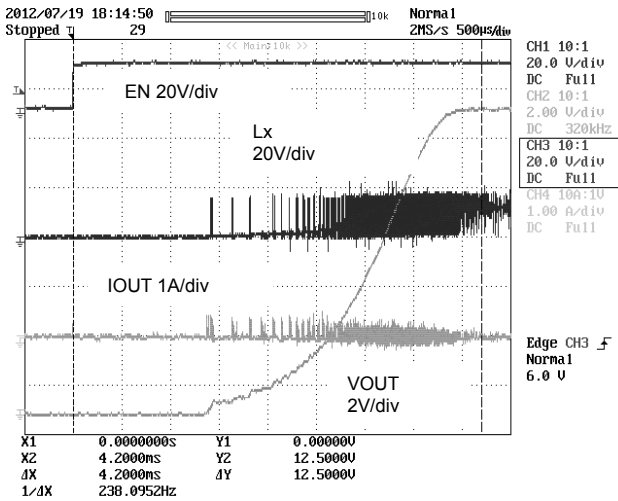

Figure 34. Start-up Characteristics  
VIN=24V, IOU=0mA, VOUT=12V

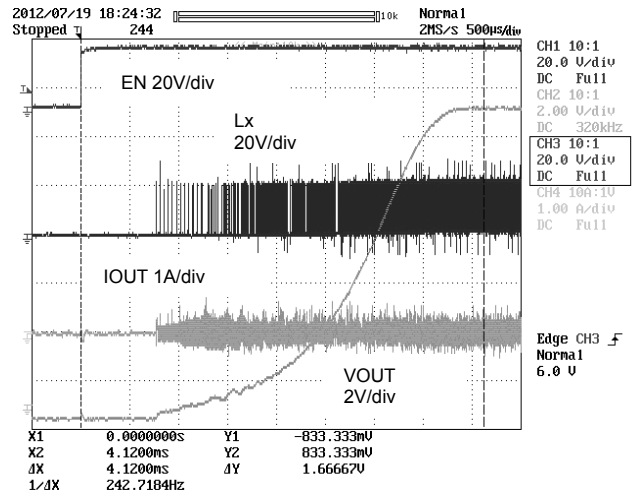

Figure 35. Start-up Characteristics  
VIN=24V, IOU=500mA, VOUT=12V

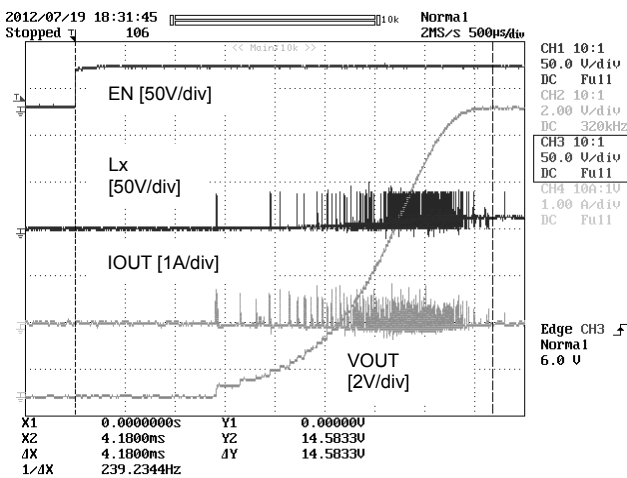

Figure 36. Start-up Characteristics  
VIN=42V, IOU=0mA, VOUT=12V

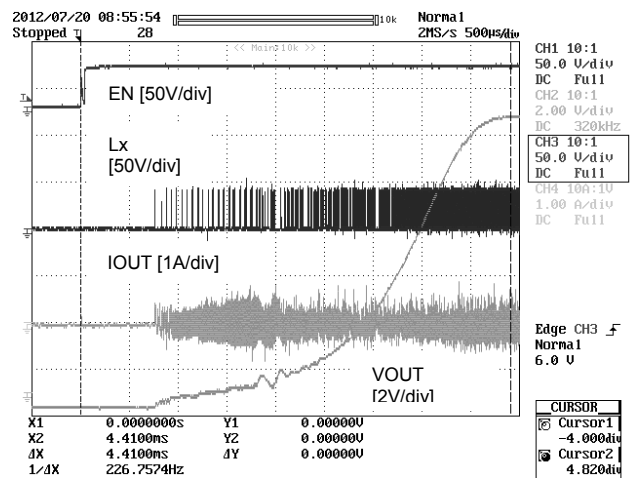

Figure 37. Start-up Characteristics  
VIN=42V, IOU=500mA, VOUT=12V

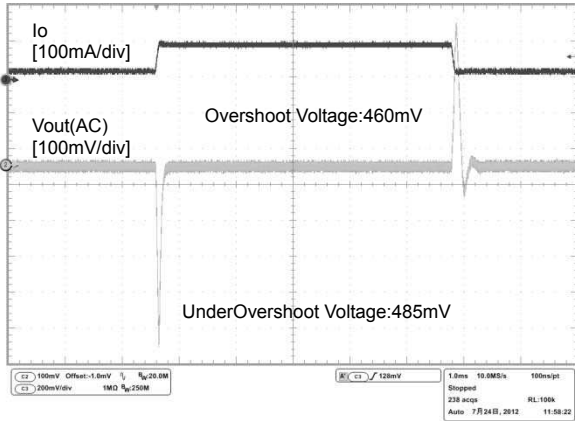

Figure 38. Load Response  
Io=50mA↔200mA, VOUT=12V

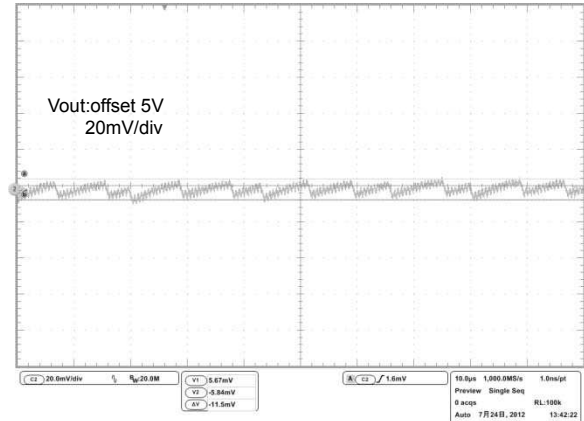

Figure 39. Lx Switching/ Vout Ripple  
Io = 50mA, VOUT=12V

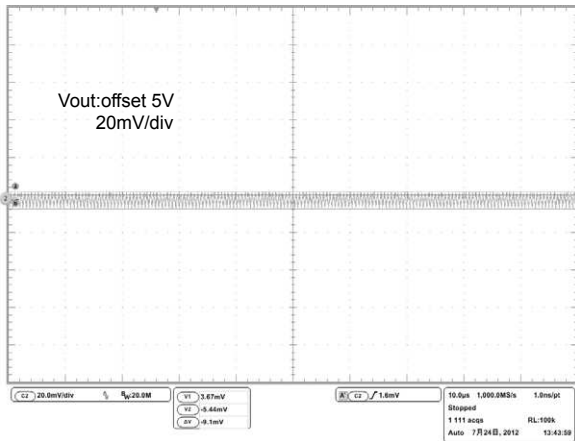

Figure 40. Lx Switching/ Vout Ripple  
Io = 200mA, VOUT=12V

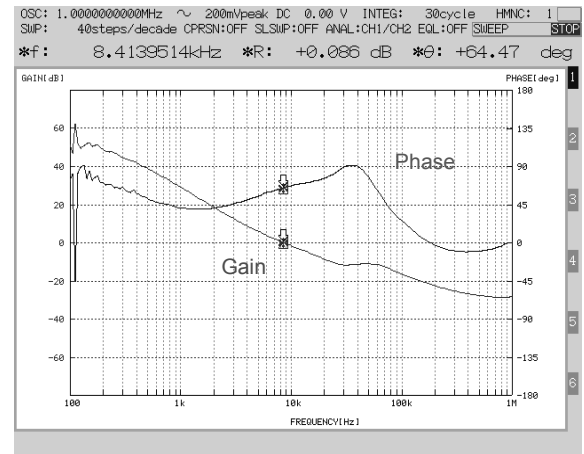

Figure 41. Frequency Response  
Io=100mA, VOUT=12V

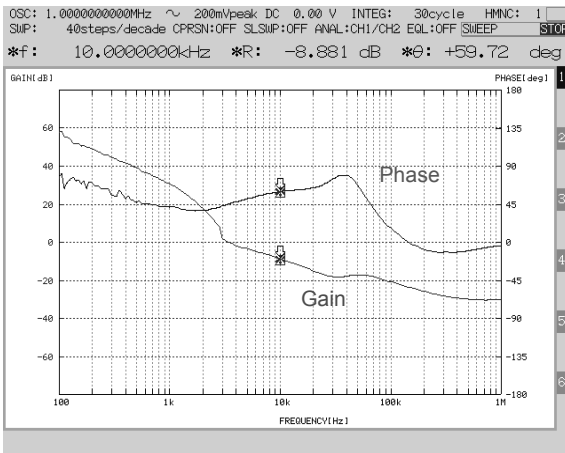

Figure 42. Frequency Response  
Io=500mA, VOUT=12V

●Application Components Selection Method

(1) Inductors

Something of the shield type that fulfills the current rating (Current value I<sub>pecac</sub> below), with low DCR is recommended. Value of Inductance influences Inductor Ripple Current and becomes the cause of Output Ripple. In the same way as the formula below, this Ripple Current can be made small for as big as the L value of Coil or as high as the Switching Frequency.

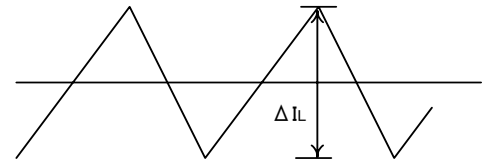

Figure 43. Inductor Current

$$I_{peak} = I_{out} + \Delta I_L / 2 \text{ [A]} \quad (1)$$

$$\Delta I_L = \frac{V_{in} - V_{out}}{L} \times \frac{V_{out}}{V_{in}} \times \frac{1}{f} \text{ [A]} \quad (2)$$

( $\Delta I_L$ : Output Ripple Current, f: Switching Frequency)

For design value of Inductor Ripple Current, please carry out design tentatively with about 20%~50% of Maximum Input Current.

In the BD9G101G, it is recommended the below series of 2.2 $\mu$ H~10 $\mu$ H inductance value.

**Recommended Inductor** TOKO DE4518C Series  
 TAIYO YUDEN NR4018 Series

(2) Output Capacitor

In order for capacitor to be used in output to reduce output ripple, Low ceramic capacitor of ESR is recommended. Also, for capacitor rating, on top of putting into consideration DC Bias characteristics, please use something whose maximum rating has sufficient margin with respect to the Output Voltage. Output ripple voltage is looked for using the following formula.

$$V_{pp} = \Delta I_L \times \frac{1}{2\pi \times f \times C_o} + \Delta I_L \times R_{ESR} \text{ [V]} \quad (3)$$

Please design in a way that it is held within Capacity Ripple Voltage.

In the BD9G101G, it is recommended a ceramic capacitor over 10 $\mu$ F.

(3) Output Voltage Setting

ERROR AMP internal Standard Voltage is 0.75V. Output Voltage is determined as seen in (4) formula.

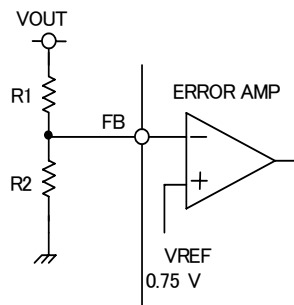

$$V_o = \frac{(R1+R2)}{R2} \times 0.75[V] \dots (4)$$

Figure 44. Voltage Setting

(4) Bootstrap Capacitor

Please connect from 15000pF (Laminate Ceramic Capacitor) between BST Pin and Lx Pins.

(5) Diode

Select suitable shottky diode for break down voltage and input current.

● Cautions on PC Board layout

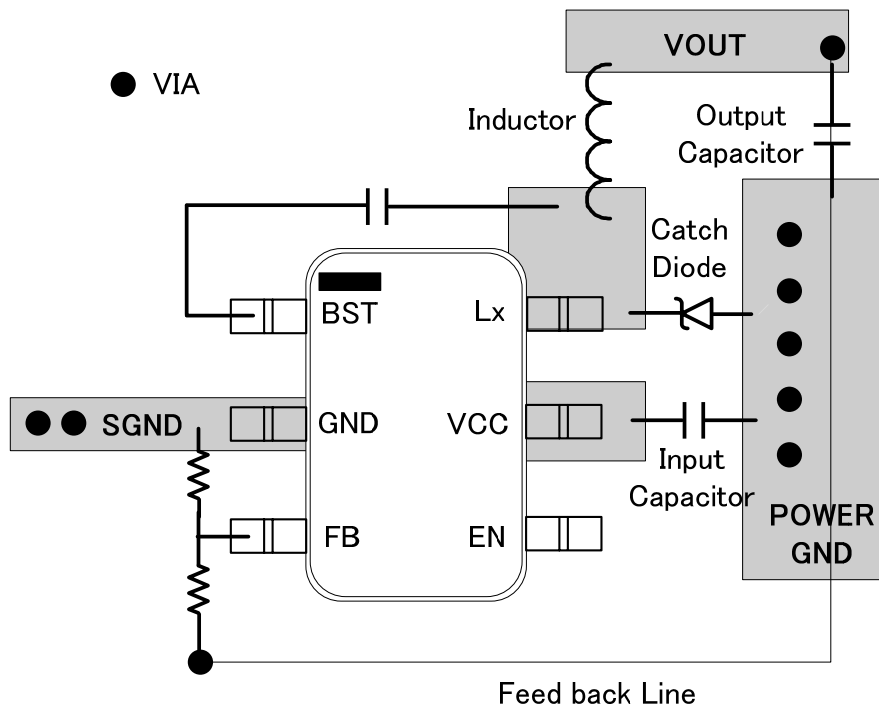

Figure 45. Reference PCB layout

Layout is a critical portion of good power supply design. There are several signals paths that conduct fast changing currents or voltages that can interact with stray inductance or parasitic capacitance to generate noise or degrade the power supplies performance. To help eliminate these problems, the VCC pin should be bypassed to ground with a low ESR ceramic bypass capacitor with B dielectric. Care should be taken to minimize the loop area formed by the bypass capacitor connections, the VCC pin, and the anode of the catch diode. See Figure.45 for a PCB layout example.

In the BD9G101G, since the LX connection is the switching node, the catch diode and output inductor should be located close to the LX pins, and the area of the PCB conductor minimized to prevent excessive capacitive coupling. And GND area should not be connected directly power GND, connected avoiding the high current switch paths. The additional external components can be placed approximately as shown.



### ●Power Dissipation

It is shown below reducing characteristics of power dissipation to mount 70mm × 70mm × 1.6mm<sup>t</sup>, 1layer PCB.  
Junction temperature must be designed not to exceed 150°C

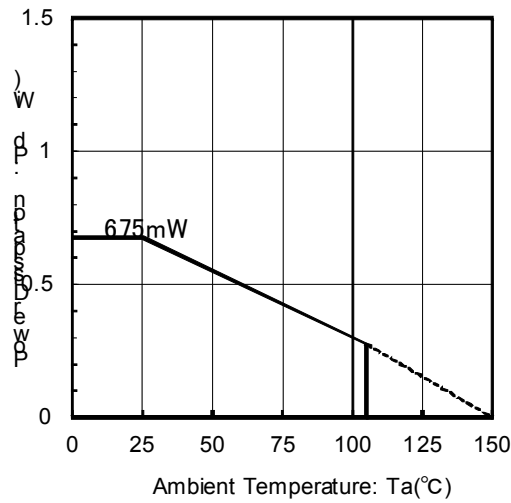

Figure 46. Power Dissipation ( 70mm × 70mm × 1.6mm<sup>t</sup> 1layer PCB)

### ●Power Dissipation Estimate

The following formulas show how to estimate the device power dissipation under continuous mode operations. They should not be used if the device is working in the discontinuous conduction mode.

The device power dissipation includes:

- 1) Conduction loss :  $P_{con} = I_{OUT}^2 \times R_{onH} \times V_{OUT}/V_{CC}$
- 2) Switching loss:  $P_{sw} = 0.41 \times 10^{-9} \times V_{CC}^2 \times I_{OUT} \times f_{sw}$
- 3) Gate charge loss :  $P_{gc} = 4.88 \times 10^{-9} \times f_{sw}$
- 4) Quiescent current loss :  $P_q = 0.8 \times 10^{-3} \times V_{CC}$

Where:

$I_{OUT}$  is the output current (A) ,  $R_{onH}$  is the on-resistance of the high-side MOSFET ( $\Omega$ ) ,  $V_{OUT}$  is the output voltage (V).  
 $V_{CC}$  is the input voltage (V),  $f_{sw}$  is the switching frequency (Hz).

Therefore

Power dissipation of IC is the sum of above dissipation.

$$P_d = P_{con} + P_{sw} + P_{gc} + P_q$$

$$\text{For given } T_j, T_j = T_a + \theta_{ja} \times P_d$$

Where:

$P_d$  is the total device power dissipation (W),  $T_a$  is the ambient temperature (°C)

$T_j$  is the junction temperature (°C),  $\theta_{ja}$  is the thermal resistance of the package (°C)

● I/O equivalent circuit

Pin. No	Pin Name	Pin Equivalent Circuit	Pin. No	Pin Name	Pin Equivalent Circuit
6 2 1 5	Lx GND BST VCC		4	EN	
3	FB				

Figure 47. I/O equivalent circuit

## ●Notes for use

- (1) About Absolute Maximum Rating  
When the absolute maximum ratings of application voltage, operating temperature range, etc. was exceeded, there is possibility of deterioration or destruction. Also, the short Mode or open mode, etc. destruction condition cannot be assumed. When the special mode where absolute maximum rating is exceeded is assumed, please give consideration to the physical safety countermeasure for the fuse, etc.
- (2) About GND Electric Potential  
In every state, please make the electric potential of GND Pin into the minimum electrical potential. Also, include the actual excessive effect, and please do it such that the pins, excluding the GND Pin do not become the voltage below GND.
- (3) About Heat Design  
Consider the Power Dissipation (Pd) in actual state of use, and please make Heat Design with sufficient margin.
- (4) About short circuit between pins and erroneous mounting  
When installing to set board, please be mindful of the direction of the IC, phase difference, etc. If it is not installed correctly, there is a chance that the IC will be destroyed. Also, if a foreign object enters the middle of output, the middle of output and power supply GND, etc., even for the case where it is shorted, there is a change of destruction.
- (5) About the operation inside a strong electro-magnetic field  
When using inside a strong electro-magnetic field, there is a possibility of error, so please be careful.
- (6) About checking with Set boards  
When doing examination with the set board, during connection of capacitor to the pin that has low impedance, there is a possibility of stress in the IC, so for every 1 process, please make sure to do electric discharge. As a countermeasure for static electricity, in the process of assembly, do grounding, and when transporting or storing please be careful. Also, when doing connection to the jig in the examination process, please make sure to turn off the power supply, then connect. After that, turn off the power supply then take it off.
- (7) About common impedance  
For the power supply and the wire of GND, lower the common impedance, then, as much as possible, make the ripple smaller (as much as possible make the wire thick and short, and lower the ripple from  $L \cdot C$ ), etc., then and please consider it sufficiently.
- (8) In the application, when the mode where the VCC and each pin electrical potential becomes reversed exists, there is a possibility that the internal circuit will become damaged. For example, during cases wherein the condition when charge was given in the external capacitor, and the VCC was shorted to GND, it is recommended to insert the bypass diode to the diode of the back current prevention in the VCC series or the middle of each Pin-VCC.
- (9) About IC Pin Input  
This IC is a Monolithic IC, and between each element, it has P<sup>+</sup> isolation for element separation and P board. With the N layer of each element and this, the P-N junction is formed, and the parasitic element of each type is composed.  
For example, like the diagram below, when resistor and transistor is connected to Pin,  
○When GND > (PinA) in Resistor, when GND > (PinA), when GND > (PinB) in Transistor (NPN), the P-N junction will operate as a parasitic diode.  
○Also, during GND > (Pin B) in the Transistor (NPN), through the N layer of the other elements connected to the above-mentioned parasitic diode, the parasitic NPN Transistor will operation.  
On the composition of IC, depending on the electrical potential, the parasitic element will become necessary. Through the operation of the parasitic element interference of circuit operation will arouse, and error, therefore destruction can be caused. Therefore please be careful about the applying of voltage lower than the GND (P board) in I/O Pin, and the way of using when parasitic element operating.

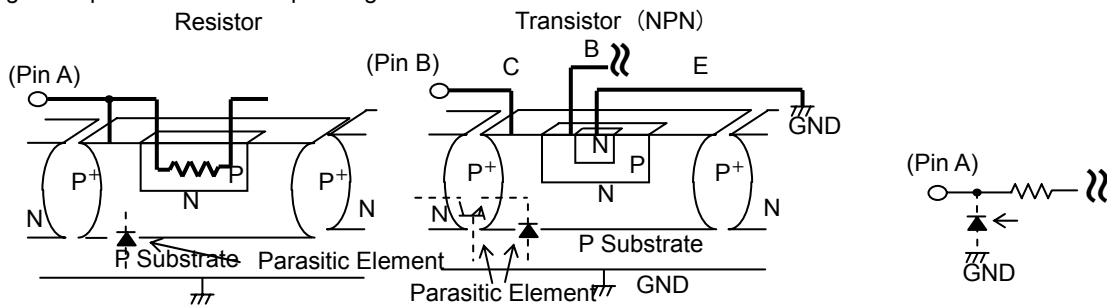

Figure 48. Example of simple structure of Bipolar IC

## Status of this document

The English version of this document is formal specification. A customer may use this translation version only for a reference to help reading the formal version.

If there are any differences in translation version of this document formal version takes priority

●Ordering part number

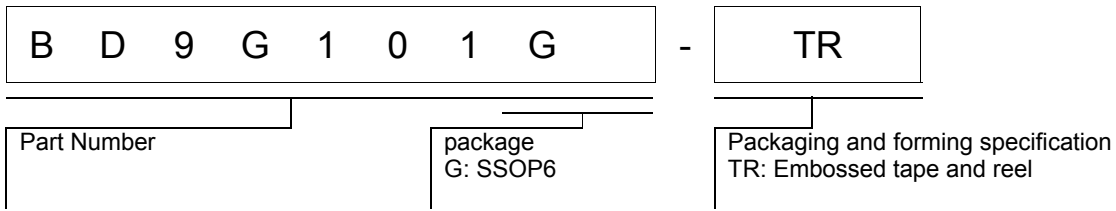

●External information

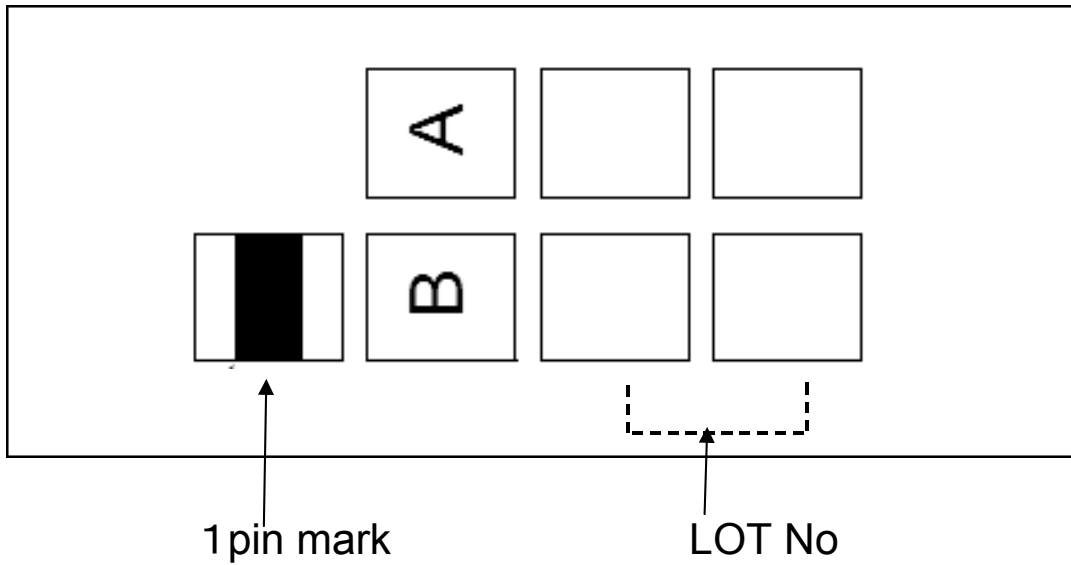

SSOP6

<Tape and Reel information>	
Tape	Embossed carrier tape
Quantity	3000pcs
Direction of feed	TR ( The direction is the 1 pin of product is at the upper right when you hold reel on the left hand and you pull out the tape on the right hand )

The diagram shows a carrier tape with five components. An arrow labeled 'Reel' points to the left side of the tape. An arrow labeled 'Direction of feed' points to the right side of the tape. A label '1 pin' points to the top-right corner of the third component from the left.

\*Order quantity needs to be multiple of the minimum quantity.

# Notice

## ●General Precaution

- 1) Before you use our Products, you are requested to carefully read this document and fully understand its contents. ROHM shall not be in any way responsible or liable for failure, malfunction or accident arising from the use of any ROHM's Products against warning, caution or note contained in this document.
- 2) All information contained in this document is current as of the issuing date and subject to change without any prior notice. Before purchasing or using ROHM's Products, please confirm the latest information with a ROHM sales representative.

## ●Precaution on using ROHM Products

- 1) Our Products are designed and manufactured for application in ordinary electronic equipments (such as AV equipment, OA equipment, telecommunication equipment, home electronic appliances, amusement equipment, etc.). If you intend to use our Products in devices requiring extremely high reliability (such as medical equipment, transport equipment, traffic equipment, aircraft/spacecraft, nuclear power controllers, fuel controllers, car equipment including car accessories, safety devices, etc.) and whose malfunction or failure may cause loss of human life, bodily injury or serious damage to property ("Specific Applications"), please consult with the ROHM sales representative in advance. Unless otherwise agreed in writing by ROHM in advance, ROHM shall not be in any way responsible or liable for any damages, expenses or losses incurred by you or third parties arising from the use of any ROHM's Products for Specific Applications.
- 2) ROHM designs and manufactures its Products subject to strict quality control system. However, semiconductor products can fail or malfunction at a certain rate. Please be sure to implement, at your own responsibilities, adequate safety measures including but not limited to fail-safe design against the physical injury, damage to any property, which a failure or malfunction of our Products may cause. The following are examples of safety measures:
  - [a] Installation of protection circuits or other protective devices to improve system safety
  - [b] Installation of redundant circuits to reduce the impact of single or multiple circuit failure
- 3) Our Products are designed and manufactured for use under standard conditions and not under any special or extraordinary environments or conditions, as exemplified below. Accordingly, ROHM shall not be in any way responsible or liable for any damages, expenses or losses arising from the use of any ROHM's Products under any special or extraordinary environments or conditions. If you intend to use our Products under any special or extraordinary environments or conditions (as exemplified below), your independent verification and confirmation of product performance, reliability, etc. prior to use, must be necessary:
  - [a] Use of our Products in any types of liquid, including water, oils, chemicals, and organic solvents
  - [b] Use of our Products outdoors or in places where the Products are exposed to direct sunlight or dust
  - [c] Use of our Products in places where the Products are exposed to sea wind or corrosive gases, including Cl<sub>2</sub>, H<sub>2</sub>S, NH<sub>3</sub>, SO<sub>2</sub>, and NO<sub>2</sub>
  - [d] Use of our Products in places where the Products are exposed to static electricity or electromagnetic waves
  - [e] Use of our Products in proximity to heat-producing components, plastic cords, or other flammable items
  - [f] Sealing or coating our Products with resin or other coating materials
  - [g] Use of our Products without cleaning residue of flux (even if you use no-clean type fluxes, cleaning residue of flux is recommended); or Washing our Products by using water or water-soluble cleaning agents for cleaning residue after soldering
  - [h] Use of the Products in places subject to dew condensation
- 4) The Products are not subject to radiation-proof design.
- 5) Please verify and confirm characteristics of the final or mounted products in using the Products.
- 6) In particular, if a transient load (a large amount of load applied in a short period of time, such as pulse) is applied, confirmation of performance characteristics after on-board mounting is strongly recommended. Avoid applying power exceeding normal rated power; exceeding the power rating under steady-state loading condition may negatively affect product performance and reliability.
- 7) De-rate Power Dissipation (Pd) depending on Ambient temperature (Ta). When used in sealed area, confirm the actual ambient temperature.
- 8) Confirm that operation temperature is within the specified range described in the product specification.
- 9) ROHM shall not be in any way responsible or liable for failure induced under deviant condition from what is defined in this document.

**●Precaution for Mounting / Circuit board design**

- 1) When a highly active halogenous (chlorine, bromine, etc.) flux is used, the residue of flux may negatively affect product performance and reliability.
- 2) In principle, the reflow soldering method must be used; if flow soldering method is preferred, please consult with the ROHM representative in advance.

For details, please refer to ROHM Mounting specification

**●Precautions Regarding Application Examples and External Circuits**

- 1) If change is made to the constant of an external circuit, please allow a sufficient margin considering variations of the characteristics of the Products and external components, including transient characteristics, as well as static characteristics.
- 2) You agree that application notes, reference designs, and associated data and information contained in this document are presented only as guidance for Products use. Therefore, in case you use such information, you are solely responsible for it and you must exercise your own independent verification and judgment in the use of such information contained in this document. ROHM shall not be in any way responsible or liable for any damages, expenses or losses incurred by you or third parties arising from the use of such information.

**●Precaution for Electrostatic**

This Product is electrostatic sensitive product, which may be damaged due to electrostatic discharge. Please take proper caution in your manufacturing process and storage so that voltage exceeding the Products maximum rating will not be applied to Products. Please take special care under dry condition (e.g. Grounding of human body / equipment / solder iron, isolation from charged objects, setting of Ionizer, friction prevention and temperature / humidity control).

**●Precaution for Storage / Transportation**

- 1) Product performance and soldered connections may deteriorate if the Products are stored in the places where:
  - [a] the Products are exposed to sea winds or corrosive gases, including Cl<sub>2</sub>, H<sub>2</sub>S, NH<sub>3</sub>, SO<sub>2</sub>, and NO<sub>2</sub>
  - [b] the temperature or humidity exceeds those recommended by ROHM
  - [c] the Products are exposed to direct sunshine or condensation
  - [d] the Products are exposed to high Electrostatic
- 2) Even under ROHM recommended storage condition, solderability of products out of recommended storage time period may be degraded. It is strongly recommended to confirm solderability before using Products of which storage time is exceeding the recommended storage time period.
- 3) Store / transport cartons in the correct direction, which is indicated on a carton with a symbol. Otherwise bent leads may occur due to excessive stress applied when dropping of a carton.
- 4) Use Products within the specified time after opening a humidity barrier bag. Baking is required before using Products of which storage time is exceeding the recommended storage time period.

**●Precaution for Product Label**

QR code printed on ROHM Products label is for ROHM's internal use only.

**●Precaution for Disposition**

When disposing Products please dispose them properly using an authorized industry waste company.

**●Precaution for Foreign Exchange and Foreign Trade act**

Since our Products might fall under controlled goods prescribed by the applicable foreign exchange and foreign trade act, please consult with ROHM representative in case of export.

**●Precaution Regarding Intellectual Property Rights**

- 1) All information and data including but not limited to application example contained in this document is for reference only. ROHM does not warrant that foregoing information or data will not infringe any intellectual property rights or any other rights of any third party regarding such information or data. ROHM shall not be in any way responsible or liable for infringement of any intellectual property rights or other damages arising from use of such information or data.:
- 2) No license, expressly or implied, is granted hereby under any intellectual property rights or other rights of ROHM or any third parties with respect to the information contained in this document.

●Other Precaution

- 1) The information contained in this document is provided on an "as is" basis and ROHM does not warrant that all information contained in this document is accurate and/or error-free. ROHM shall not be in any way responsible or liable for any damages, expenses or losses incurred by you or third parties resulting from inaccuracy or errors of or concerning such information.
- 2) This document may not be reprinted or reproduced, in whole or in part, without prior written consent of ROHM.
- 3) The Products may not be disassembled, converted, modified, reproduced or otherwise changed without prior written consent of ROHM.
- 4) In no event shall you use in any way whatsoever the Products and the related technical information contained in the Products or this document for any military purposes, including but not limited to, the development of mass-destruction weapons.
- 5) The proper names of companies or products described in this document are trademarks or registered trademarks of ROHM, its affiliated companies or third parties.