

AC/DC Drivers



# PWM type DC/DC converter IC Included 650V MOSFET

## BM2PXX4 Series

**•General**

The PWM type DC/DC converter (BM2PXX4) for AC/DC provide an optimum system for all products that include an electrical outlet.  
 BM2PXX4 supports both isolated and non-isolated devices, enabling simpler design of various types of low-power electrical converters.  
 BM2PXX4 built in a HV starter circuit that tolerates 650V, it contributes to low-power consumption.  
 With current detection resistors as external devices, a higher degree of design freedom is achieved. Since current mode control is utilized, current is restricted in each cycle and excellent performance is demonstrated in bandwidth and transient response.  
 The switching frequency is 65 kHz. At light load, the switching frequency is reduced and high efficiency is achieved.  
 A frequency hopping function is also on chip, which contributes to low EMI.  
 We can design easily, because BM2PXX4 includes the switching MOSFET.

**•Basic specifications**

- Operating Power Supply Voltage Range:  
VCC 8.9V to 26.0V DRAIN : ~650V
- Operating Current: Normal Mode  
 BM2P014 :0.950mA (Typ.)  
 BM2P034 :0.775mA(Typ)  
 BM2P054 : 0.600mA(Typ)  
 BM2P094 : 0.500mA(Typ)  
 Burst Mode : 0.400mA(Typ.)
- Oscillation Frequency: 65kHz(Typ.)
- Operating Temperature: - 40deg. to +105deg.
- MOSFET ON Resistance:  
 BM2P014:1.4Ω(Typ)  
 BM2P034:2.4Ω(Typ)  
 BM2P054:4.0Ω(Typ)  
 BM2P094:8.5Ω(Typ)

**•Application circuit**

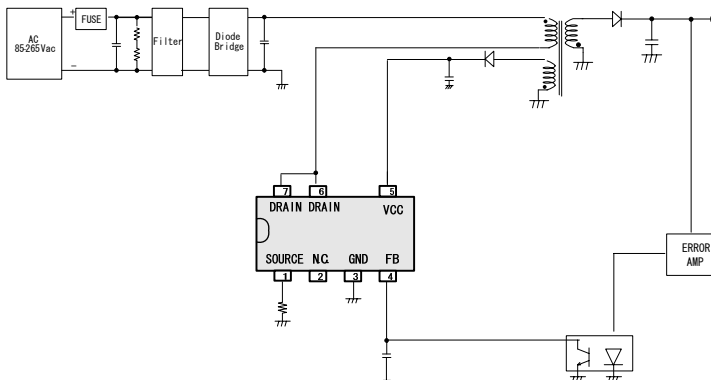

Figure 1. Application circuit

**•Features**

- PWM frequency : 65kHz
- PWM current mode method
- Burst operation when load is light
- Frequency reduction function
- Built-in 650V start circuit
- Built-in 650V switching MOSFET
- VCC pin under voltage protection
- VCC pin overvoltage protection
- SOURCE pin Open protection
- SOURCE pin Short protection
- SOURCE pin Leading-Edge-Blanking function
- Per-cycle over current protection circuit
- Soft start
- Secondary Over current protection circuit

**•Package**

DIP7 9.20mm×6.35mm×4.30mm pitch 2.54mm  
 (Typ.) (Typ.) (Typ.) (TYP.)



**•Applications**

AC adapters and household appliances (vacuum cleaners, humidifiers, air cleaners, air conditioners, IH cooking heaters, rice cookers, etc.)

**•Line Up**

Product	MOSFET ON resistor
BM2P014	1.4Ω
BM2P034	2.4Ω
BM2P054	4.0Ω
BM2P094	8.5Ω

○Product structure : Silicon monolithic integrated circuit ○This product is not designed protection against radioactive rays

●Absolute Maximum Ratings (Ta=25°C)

Parameter	Symbol	Rating	Unit	Conditions
Maximum applied voltage 1	V <sub>max1</sub>	-0.3~30	V	VCC
Maximum applied voltage 2	V <sub>max2</sub>	-0.3~6.5	V	SOURCE, FB
Maximum applied voltage 3	V	650	V	DRAIN
Drain current pulse	I <sub>DP</sub>	10.40	A	P <sub>w</sub> =10us, Duty cycle=1% (BM2P014)
Drain current pulse	I <sub>DP</sub>	5.20	A	P <sub>w</sub> =10us, Duty cycle=1% (BM2P034)
Drain current pulse	I <sub>DP</sub>	2.60	A	P <sub>w</sub> =10us, Duty cycle=1% (BM2P054)
Drain current pulse	I <sub>DP</sub>	1.30	A	P <sub>w</sub> =10us, Duty cycle=1% (BM2P094)
Allowable dissipation	P <sub>d</sub>	2000	mW	When implemented
Operating temperature range	T <sub>opr</sub>	-40 ~ +105	°C	
Storage temperature range	T <sub>str</sub>	-55 ~ +150	°C	

(Note1) DIP7 : When mounted (on 74.2 mm × 74.2 mm, 1.6 mm thick, glass epoxy on single-layer substrate).  
Reduce to 16 mW/°C when Ta = 25°C or above.

●Operating Conditions (Ta=25°C)

Parameter	Symbol	Rating	Unit	Conditions
Power supply voltage range 1	VCC	8.9~26.0	V	VCC pin voltage
Power supply voltage range 2	V <sub>DRAIN</sub>	~650	V	DRAIN pin voltage

●Electrical Characteristics of MOSFET part (Unless otherwise noted, Ta = 25°C, VCC = 15 V)

Parameter	Symbol	Specifications			Unit	Conditions
		Minimum	Standard	Maximum		
<b>[MOSFET Block ]</b>						
Between drain and source voltage	V <sub>(BR)DDS</sub>	650	-	-	V	I <sub>b</sub> =1mA / V <sub>GS</sub> =0V
Drain leak current	I <sub>DSS</sub>	-	-	100	uA	V <sub>DS</sub> =650V / V <sub>GS</sub> =0V
On resistance	R <sub>DS(ON)</sub>	-	1.4	2.0	Ω	I <sub>b</sub> =0.25A / V <sub>GS</sub> =10V (BM2P014)
On resistance	R <sub>DS(ON)</sub>	-	2.4	3.6	Ω	I <sub>b</sub> =0.25A / V <sub>GS</sub> =10V (BM2P034)
On resistance	R <sub>DS(ON)</sub>	-	4.0	5.5	Ω	I <sub>b</sub> =0.25A / V <sub>GS</sub> =10V (BM2P054)
On resistance	R <sub>DS(ON)</sub>	-	8.5	12.0	Ω	I <sub>b</sub> =0.25A / V <sub>GS</sub> =10V (BM2P094)

## ●Electrical Characteristics (Unless otherwise noted, Ta = 25°C, VCC = 15 V)

Parameter	Symbol	Specifications			Unit	Conditions
		Minimum	Standard	Maximum		
<b>[Circuit current]</b>						
Circuit current (ON) 1	I <sub>ON1</sub>	700	950	1200	μA	BM2P014, FB=2.0V ( at pulse operation)
Circuit current (ON) 1	I <sub>ON1</sub>	550	775	1050	μA	BM2P034, FB=2.0V (at pulse operation)
Circuit current (ON) 1	I <sub>ON1</sub>	410	600	790	μA	BM2P054, FB=2.0V (at pulse operation)
Circuit current (ON) 1	I <sub>ON1</sub>	350	500	650	μA	BM2P094, FB=2.0V (at pulse operation)
Circuit current (ON) 2	I <sub>ON2</sub>	-	400	500	μA	FB=0.0V(at burst operation)
<b>[VCC protection function]</b>						
VCC UVLO voltage 1	V <sub>UVLO1</sub>	12.50	13.50	14.50	V	VCC rise
VCC UVLO voltage 2	V <sub>UVLO2</sub>	7.50	8.20	8.90	V	VCC drop
VCC UVLO hysteresis	V <sub>UVLO3</sub>	-	5.30	-	V	V <sub>UVLO3</sub> = V <sub>UVLO1</sub> - V <sub>UVLO2</sub>
VCC OVP voltage 1	V <sub>OVP1</sub>	26.0	27.5	29.0	V	VCC rise
VCC OVP voltage 2	V <sub>OVP2</sub>	-	23.5	-	V	VCC drop
Latch released VCC voltage	V <sub>LATCH</sub>	-	V <sub>UVLO2</sub> -0.5	-	V	
VCC Recharge start voltage	V <sub>CHG1</sub>	7.70	8.70	9.70	V	
VCC Recharge stop voltage	V <sub>CHG2</sub>	12.00	13.00	14.00	V	
Latch mask time	T <sub>LATCH</sub>	50	100	150	us	
Thermal shut down temperature	T <sub>SD</sub>	110	-	-	°C	Control IC
<b>[PWM type DCDC driver block]</b>						
Oscillation frequency 1	F <sub>SW1</sub>	60	65	70	KHz	FB=2.00V
Oscillation frequency 2	F <sub>SW2</sub>	20	25	30	KHz	FB=0.40V
Frequency hopping width 1	F <sub>DEL1</sub>	-	4.0	-	KHz	FB=2.0V
Hopping fluctuation frequency	F <sub>CH</sub>	75	125	175	Hz	
Soft start time 1	T <sub>SS1</sub>	0.30	0.50	0.70	ms	
Soft start time 2	T <sub>SS2</sub>	0.60	1.00	1.40	ms	
Soft start time 3	T <sub>SS3</sub>	1.20	2.00	2.80	ms	
Soft start time 4	T <sub>SS4</sub>	4.80	8.00	11.20	ms	
Maximum duty	D <sub>max</sub>	68.0	75.0	82.0	%	
FB pin pull-up resistance	R <sub>FB</sub>	23	30	37	kΩ	
ΔFB / ΔCS gain	Gain	-	4.00	-	V/V	
FB burst voltage	V <sub>BST</sub>	0.300	0.400	0.500	V	FB drop
FB voltage of starting Frequency reduction mode	V <sub>DLT</sub>	1.100	1.250	1.400	V	
FB OLP voltage 1a	V <sub>FOLP1a</sub>	2.60	2.80	3.00	V	Overload is detected (FB rise)
FB OLP voltage 1b	V <sub>FOLP1b</sub>	-	2.60	-	V	Overload is detected (FB drop)
FB OLP ON timer	T <sub>FOLP1</sub>	40	64	88	ms	
FB OLP Start up timer	T <sub>FOLP1b</sub>	26	32	38	ms	
FB OLP OFF timer	T <sub>FOLP2</sub>	358	512	666	ms	
<b>[Over current detection block]</b>						
Overcurrent detection voltage	V <sub>CS</sub>	0.380	0.400	0.420	V	Ton=0us
Overcurrent detection voltage SS1	V <sub>CS_SS1</sub>	-	0.100	-	V	0[ms] ~ Tss1[ms]
Overcurrent detection voltage SS2	V <sub>CS_SS2</sub>	-	0.150	-	V	TSS1 [ms] ~ TSS2 [ms]
Overcurrent detection voltage SS3	V <sub>CS_SS3</sub>	-	0.200	-	V	TSS2 [ms] ~ TSS3[ms]
Overcurrent detection voltage SS4	V <sub>CS_SS4</sub>	-	0.300	-	V	TSS3 [ms] ~ TSS4 [ms]
Leading Edge Blanking Time	T <sub>LEB</sub>	-	250	-	ns	
Over current detection AC Voltage compensation factor	K <sub>CS</sub>	12	20	28	mV/us	
SOURCE pin short protection voltage	V <sub>CSsHT</sub>	0.020	0.050	0.080	V	
<b>[ Start circuit block ]</b>						
Start current 1	I <sub>START1</sub>	0.100	0.500	1.000	mA	VCC= 0V
Start current 2	I <sub>START2</sub>	1.000	3.000	6.000	mA	VCC=10V
OFF current	I <sub>START3</sub>	-	10	20	uA	Inflow current from Drain pin after UVLO released UVLO. When MOSFET is OFF
Start current switching voltage	V <sub>SC</sub>	0.800	1.500	2.100	V	

●PIN DESCRIPTIONS

Table 1 Pin Description

NO.	Pin Name	I/O	Function	ESD Diode	
				VCC	GND
1	SOURCE	I/O	MOSFET SOURCE pin	○	○
2	N.C.	-	-	-	-
3	GND	I/O	GND pin	○	-
4	FB	I	Feedback signal input pin	-	○
5	VCC	I	Power supply input pin	-	○
6	DRAIN	I/O	MOSFET DRAIN pin	-	-
7	DRAIN	I/O	MOSFET DRAIN pin	-	-

●I/O Equivalent Circuit Diagram

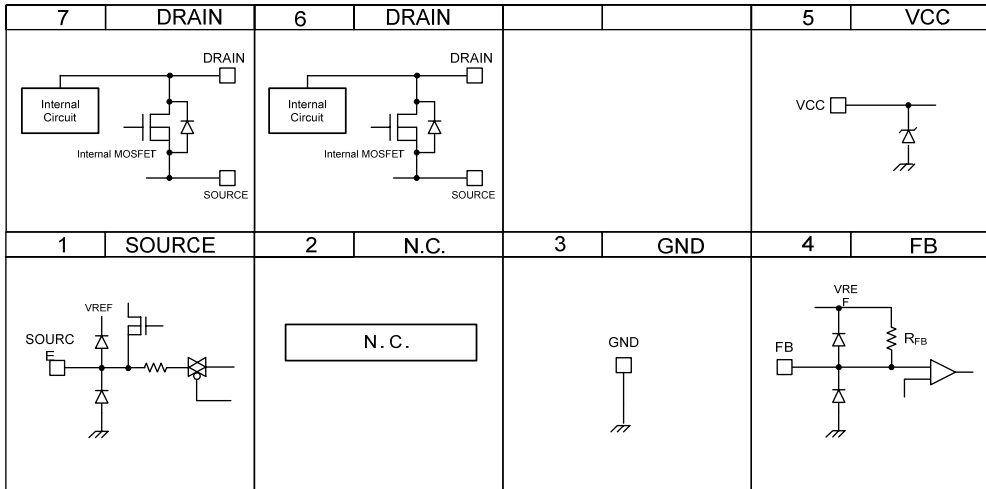

Figure 2 I/O Equivalent Circuit Diagram



•Description of Blocks

( 1 ) Start circuit (DRIAN : 6,7pin)

This IC built in Start circuit (tolerates 650V). It enables to be low standby mode electricity and high speed starting. After starting, consumption power is idling current  $I_{START3}$  (typ=10uA) only. Reference values of Starting time are shown in Figure-7. When  $C_{VCC}=10\mu F$  it can start less than 0.1 sec.

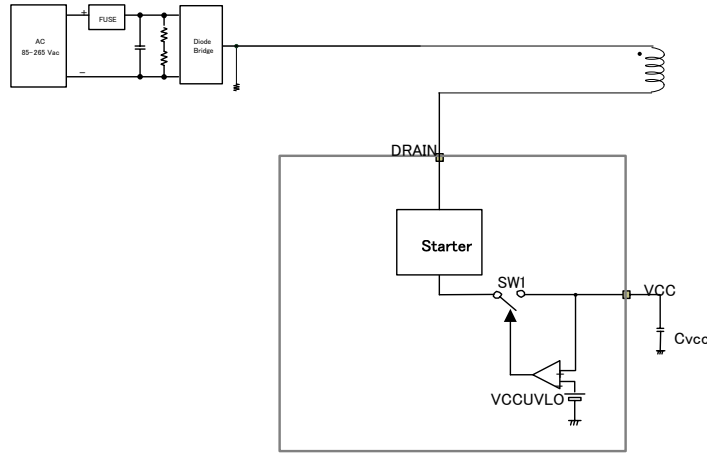

Figure 4. Block diagram of start circuit

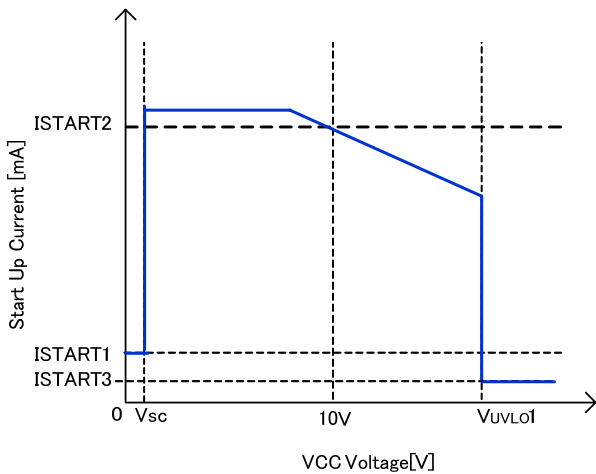

Figure 5. Start current vs VCC voltage

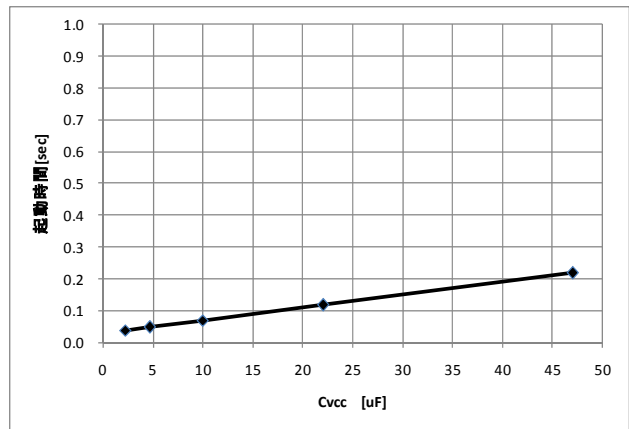

Figure 6. Start time( reference value)

\* Start current flows from the DRAIN pin

ex) Consumption power of start circuit only when the  $V_{ac}=100V$   
 $P_{VH} = 100V \cdot \sqrt{2} \cdot 10\mu A = 1.41mW$

ex) Consumption power of start circuit only when the  $V_{ac}=240V$   
 $P_{VH} = 240V \cdot \sqrt{2} \cdot 10\mu A = 3.38mW$

(2) Start sequences  
 (Soft start operation, light load operation, and auto recovery operation during overload protection)

Start sequences are shown in Figure 7. See the sections below for detailed descriptions.

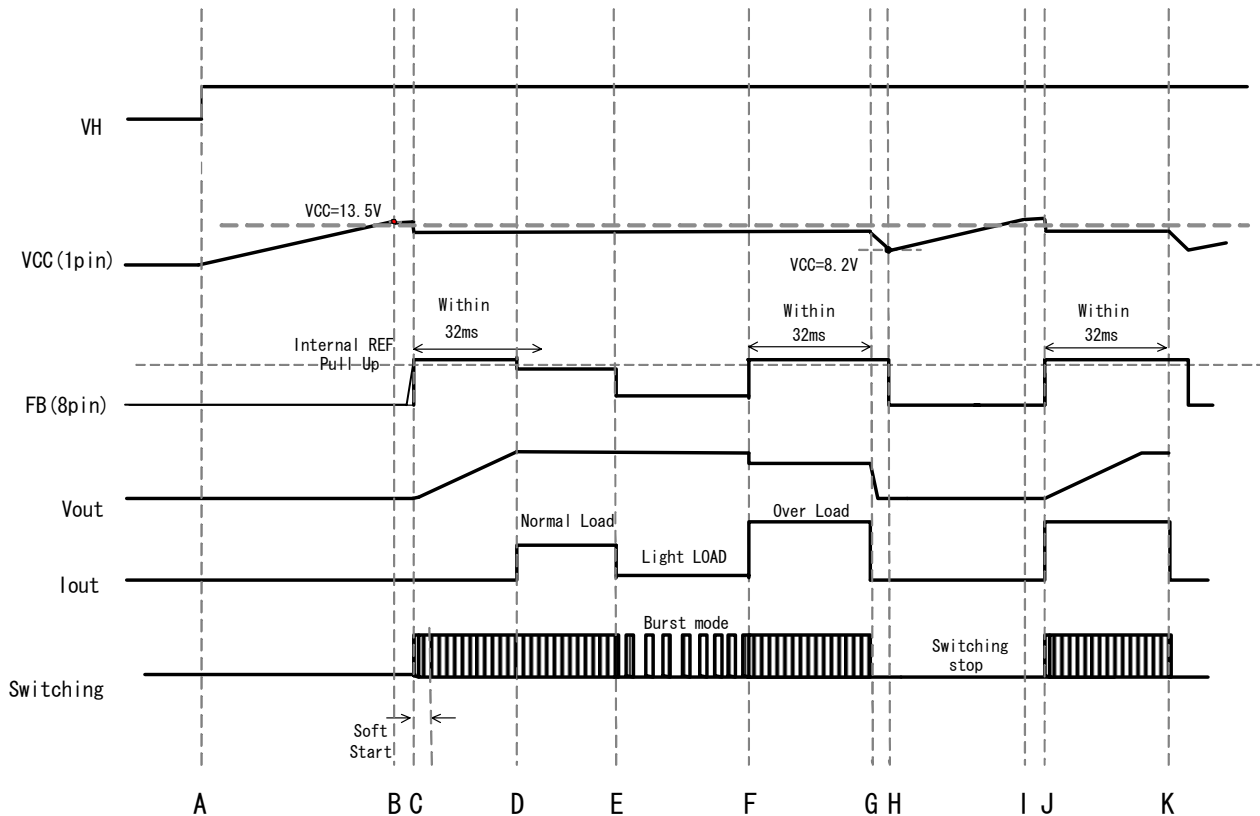

Figure 7. Start sequences Timing Chart

- A : Input voltage  $V_H$  is applied
- B : This IC starts operating  $V_{CC}$  pin voltage rises when  $V_{CC} > V_{UVLO1}$  (13.5 V typ). Switching function starts when other protection functions are judged as normal. Between the secondary output voltage become constant level, because the  $V_{CC}$  pin consumption current causes the  $V_{CC}$  value to drop, IC should set to start switching until  $V_{CC} < V_{UVLO2}$  (8.2V typ).
- C : With the soft start function, overcurrent limit value is restricted to prevent any excessive rise in voltage or current.
- D : When the switching operation starts,  $V_{OUT}$  rises. Once the output voltage starts, set the rated voltage within the  $T_{FOLP}$  period (32ms typ).
- E : When there is a light load it reaches  $FB$  voltage  $< V_{BST}$  ( $= 0.4V_{typ}$ ), burst operation is used to keep power consumption down. During burst operation, it becomes low-power consumption mode.
- F : When the  $FB$  Voltage  $> V_{FOLP1A}$  ( $= 2.8V_{typ}$ ), it becomes a overload
- G : When  $FB$  pin voltage keeps  $V_{FOLP1A}$  ( $= 2.8V_{typ}$ ) at or above  $T_{FOLP}$  (32ms typ), the overload protection function is triggered and switching stops. During the  $T_{FOLP}$  period (32ms typ) if the  $FB$  pin voltage becomes  $FB < V_{FOLP1B}$  even once, the IC's internal timer is reset.
- H : If the  $V_{CC}$  voltage drops to  $V_{CC} < V_{UVLO2}$  (7.7Vtyp) or below, restart is executed.
- I : The IC's circuit current is reduced and the  $V_{CC}$  pin value rises. (Same as B)
- J : Same as F
- K : Same as G

**(3) VCC pin protection function**

BM2PXX4 built in VCC low voltage protection function of VCCUVLO (Under Voltage Lock Out), over voltage protection function of VCC OVP (Over Voltage Protection) and VCC charge function that operates in case of dropping the VCC voltage.

This function monitors VCC pin and prevent VCC pin from destroying switching MOSFET at abnormal voltage.

VCC charge function stabilizes the secondary output voltage to be charged from the high voltage line by start circuit at dropping the VCC voltage.

**(3-1) VCC UVLO / VCC OVP function**

VCCUVLO is auto recovery comparator. VCCOVP is auto recovery comparator that has voltage hysteresis. Refer to the operation figure-8.

VCCOVP operates detection in case of continuing VCC pin voltage >  $V_{OVP}$  (typ=27.5V).

This function built in mask time  $T_{LATCH}$  (typ=100us). By this function, this IC masks pin generated surge etc.

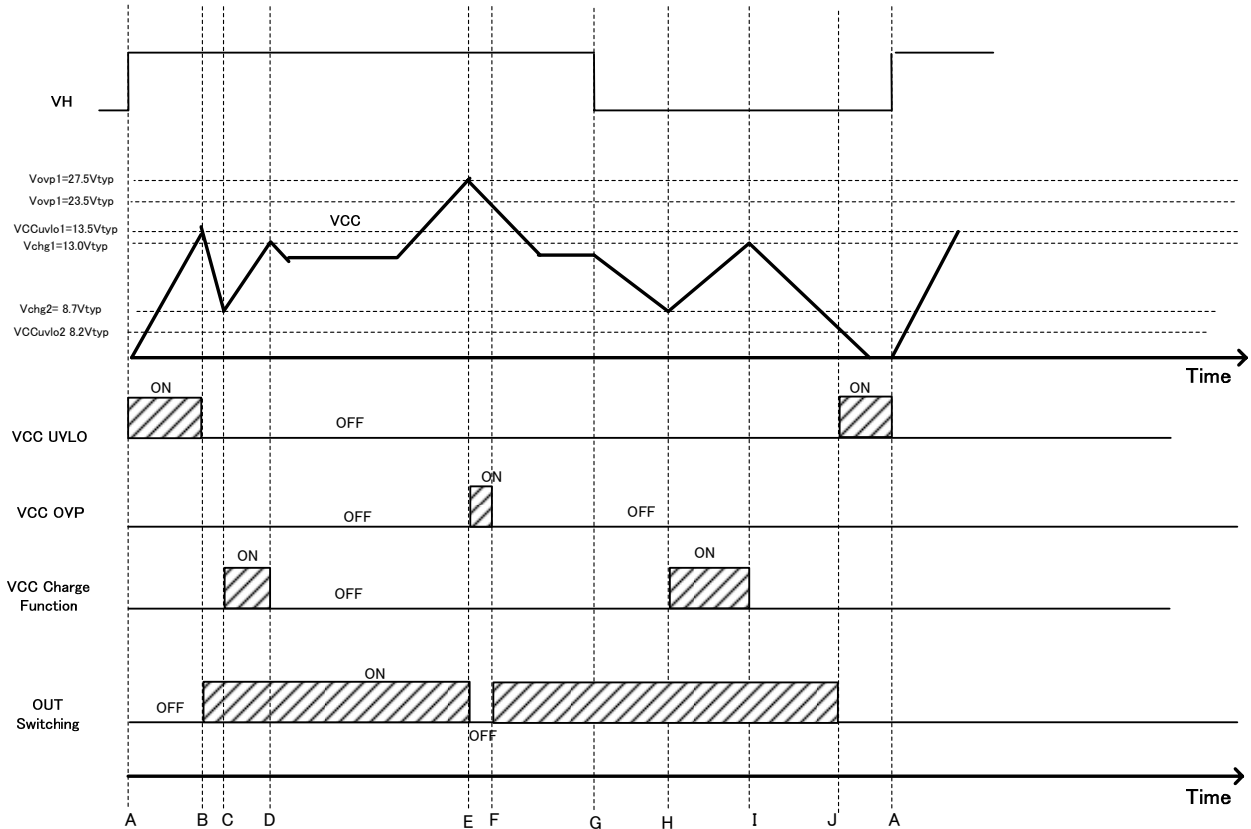

Figure 8. VCC UVLO / OVP Timing Chart

A: DRAIN voltage input, VCC pin voltage starts rising.

B:  $V_{CC} > V_{uvlo1}$ , DC/DC operation starts

C:  $V_{CC} < V_{chg1}$ , VCC charge function operates and the VCC voltage is rise.

D:  $V_{CC} > V_{chg2}$ , VCC charge function is stopped.

E:  $V_{CC} > V_{ovp1}$  continues  $T_{LATCH}$  (typ = 100us), switching is stopped by the VCCOVP function.

F:  $V_{CC} < V_{ovp2}$ , DC/DC operation restarts

G: VH is OPEN. VCC Voltage is fall.

H: Same as C.

I: Same as D.

J:  $V_{CC} < V_{uvlo2}$ , DC/DC operation stops



**(3-2)VCC Charge function**

VCC charge function operates once the VCC pin  $>V_{UVLO1}$  and the DC/DC operation starts then the VCC pin voltage drops to  $<V_{CHG1}$ . At that time the VCC pin is charged from DRAIN pin through start circuit. By this operation, BM2PXX4 doesn't occur to start failure. VCC pin voltage is rise, then  $VCC >V_{CHG2}$ , charge is stopped. The operations are shown in figure-10.

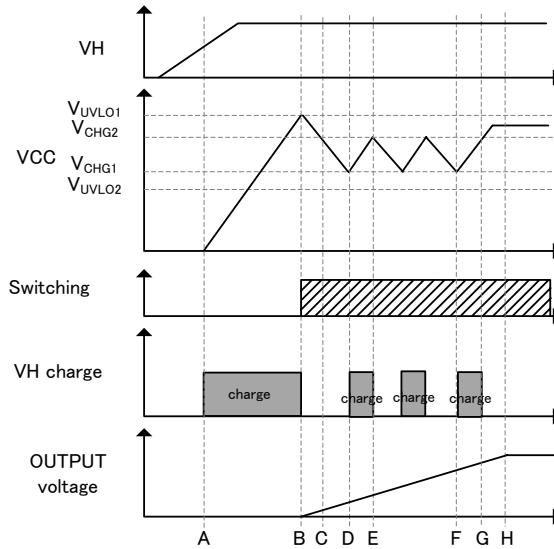

Figure 9. Charge operation VCC pin charge operation

- A: DRAIN pin voltage rises, charge starts to VCC pin by the VCC charge function.
- B:  $VCC > V_{UVLO1}$ , VCC UVLO function releases, VCC charge function stops, DC/DC operation starts.
- C: When DC/DC operation starts, the VCC voltage drops.
- D:  $VCC < V_{CHG1}$ , VCC recharge function operates.
- E:  $VCC > V_{CHG2}$ , VCC recharge function stops.
- F:  $VCC < V_{CHG1}$ , VCC recharge function operates.
- G:  $VCC < V_{CHG1}$ , VCC recharge function stops.
- H: After start of output voltage finished, VCC is charged by the auxiliary winding VCC pin stabilizes.

( 4 ) DCDC driver (PWM comparator, frequency hopping, slope compensation, OSC, burst)

BM2PXX4 is current mode PWM control.

An internal oscillator sets a fixed switching frequency (65kHz typ).

BM2PXX4 is integrated switching frequency hopping function which changes the switching frequency to fluctuate as shown in Figure 11 below.

The fluctuation cycle is 125 Hz typ.

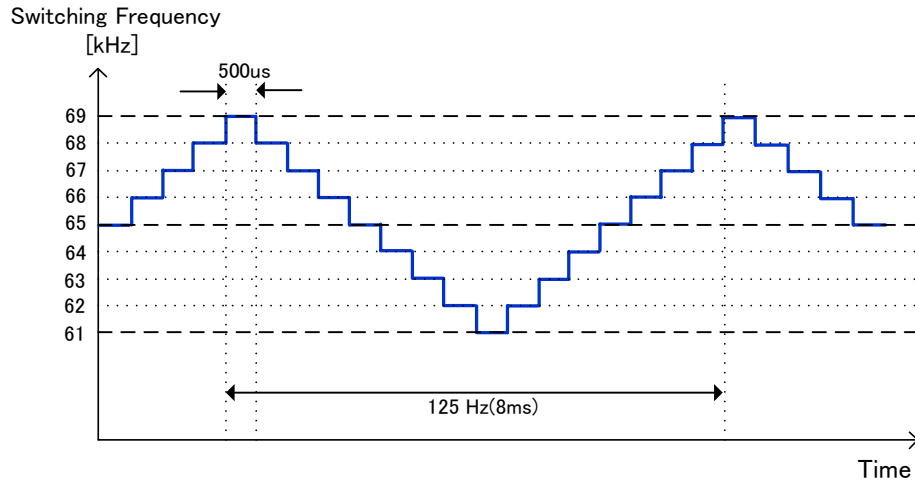

Figure 10. Frequency hopping function

Max duty cycle is fixed as 75% (typ) and MIN pulse width is fixed as 400 ns (typ).

With current mode control, when the duty cycle exceeds 50% sub harmonic oscillation may occur.

As a countermeasure to this, BM2PXX4 is built in slope compensation circuits.

BM2PXX4 is built in burst mode circuit and frequency reduction circuit to achieve lower power consumption, when the load is light.

FB pin is pull up by  $R_{FB}$  (30 kΩ typ).

FB pin voltage is changed by secondary output voltage (secondary load power).

FB pin is monitored, burst mode operation and frequency detection start.

Figure 11 shows the FB voltage, and switching frequency, DCDC operation

- mode1 : Burst operation
- mode2: Frequency reduction operation.
- mode3 : Fixed frequency operation.(operate at the max frequency)
- mode4 : Over load operation.(detect the over load state and stop the pulse operation)

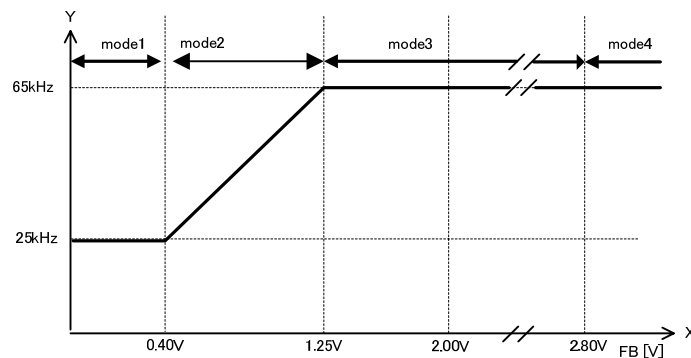

Figure 11. Switching operation state changes by FB pin voltage

**(5) Over Current limiter**

BM2PXX4 is built in Over Current limiter per cycle. If the SOURCE pin over a certain voltage, switching is stopped. It is also built in AC voltage compensation function. The function is rise over current limiter level by time to compensate AC voltage.

Shown in figure-12,13, 14.

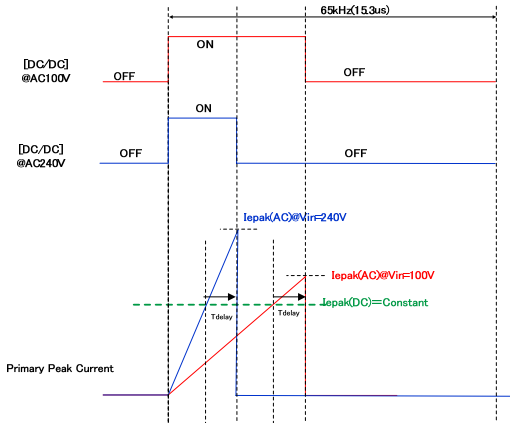

Figure 12. No AC voltage compensation function

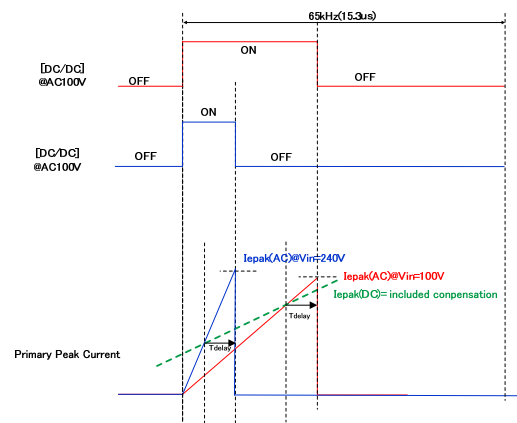

Figure 13. built-in AC compensation voltage

Primary peak current is decided as the formula below.

$$I_{peak} = V_{cs}/R_s + V_{dc}/L_p * T_{delay}$$

$V_{cs}$ : Over current limiter voltage internal IC,  $R_s$ : Current detection resistance,  $V_{dc}$  input DC voltage,  $L_p$ : Primary inductance,  $T_{delay}$ : delay time after detection of over current limiter

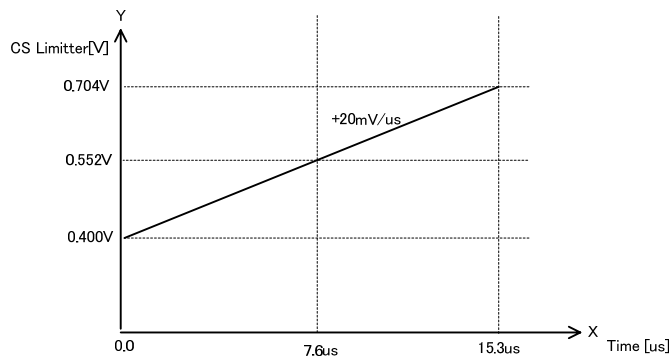

Figure 14. Over current limiter voltage

**(6) L.E.B blanking period**

When the driver MOSFET is turned ON, surge current occurs at each capacitor component and drive current. Therefore, when SOURCE pin voltage rises temporarily, the detection errors may occur in the over current limiter circuit. To prevent detection errors, DRAIN is switched from high to low and the SOURCE signal is masked for 250 ns by the on-chip LEB (Leading Edge Blanking) function.

**(7) SOURCE pin (1pin) short protection function**

When the SOURCE pin (1pin) is shorted, BM2PXX4 is over heat.  
BM2PXX4 built in short protection function to prevent destroying.

**(8) SOURCE pin (1pin) open protection**

If the SOURCE pin becomes OPEN, BM2PXX4 may be damaged.  
To prevent to be damaged, BM2PXX4 built in OPEN protection circuit (auto recovery protection).

**(9) Output over load protection function (FB OLP Comparator)**

The output overload protection function monitors the secondary output load status at the FB pin, and stops switching when an overload occurs. When there is an overload, the output voltage is reduced and current no longer flows to the photo coupler, so the FB pin voltage rises.

When the FB pin voltage  $> V_{FOLP1A}$  (2.8 V typ) continuously for the period  $T_{FOLP}$  (32ms typ), it is judged as an overload and stops switching.

When the FB pin  $> V_{FOLP1A}$  (2.8 V typ), if the voltage goes lower than  $V_{FOLP1B}$  (2.6V typ) during the period  $T_{FOLP}$  (32ms typ), the overload protection timer is reset. The switching operation is performed during this period  $T_{FOLP}$  (32ms typ).

At startup, the FB voltage is pulled up to the IC's internal voltage, so operation starts at a voltage of  $V_{FOLP1A}$  (2.8 V typ) or above. Therefore, at startup the FB voltage must be set to go to  $V_{FOLP1B}$  (2.6 Vtyp) or below during the period  $T_{FOLP}$  (32ms typ), and the secondary output voltage's start time must be set within the period  $T_{FOLP}$  (32ms typ) following startup of the IC. Recovery from the once detection of FBOLP, after the period  $T_{FOLP2}$ (512 ms typ)

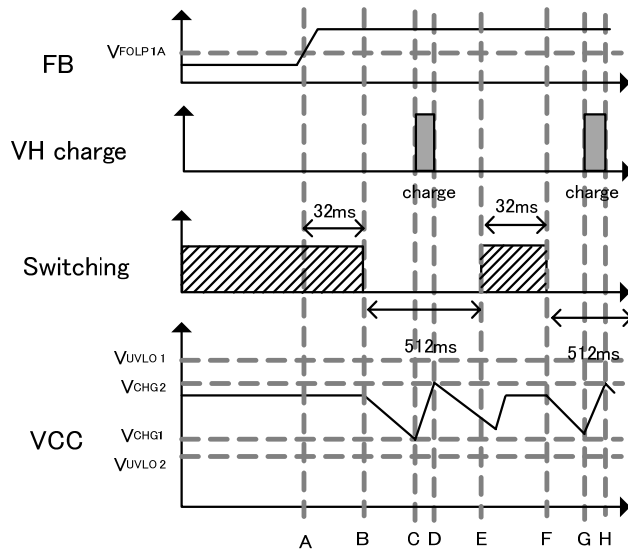

Figure 15. Over load protection (Auto recovery)

- A: The FBOLP comparator detects over load for  $FB > V_{FOLP1A}$
- B: States of A continuously for the period  $T_{FOLP}$  (32ms typ), it is judged as an overload and stops switching.
- C: While switching stops for the over load protection function, the VCC pin voltage drops and VCC pin voltage reaches  $< V_{CHG1}$ , the VCC charge function operates so the VCC pin voltage rises.
- D: VCC charge function stops when VCC pin voltage  $> V_{CHG2}$
- E: If  $T_{OLPST}$  (typ =512ms) go on from B point, Switching function starts on soft start.
- F: If  $T_{FOLP}$ (typ=32ms) go on from E point to continues a overload condition ( $FB > V_{FOLP1A}$ ), Switching function stops at F point.
- G: While switching stops VCC pin voltage drops to  $< V_{CHG1}$ , VCC charge function operates and VCC pin voltage rises.
- H: If VCC pin (1pin) voltage becomes over  $V_{CHG2}$  by the VCC charge function, VCC charge function operation stops

●Operation mode of protection circuit

Operation mode of protection functions are shown in table2.

Table2 Operation mode of protection circuit

Function	Operation mode
VCC Under Voltage Locked Out	Auto recovery
VCC Over Voltage Protection	Auto recovery
TSD	Latch (with 100us timer)
FB Over Limited Protection	Auto recovery (with 64ms timer)
SOURCE Short Protection	Auto recovery
SOURCE Open Protection	Auto recovery

●Sequence

The sequence diagram is show in Fig 16.  
All condition transits OFF Mode  $V_{CC} < 8.2V$

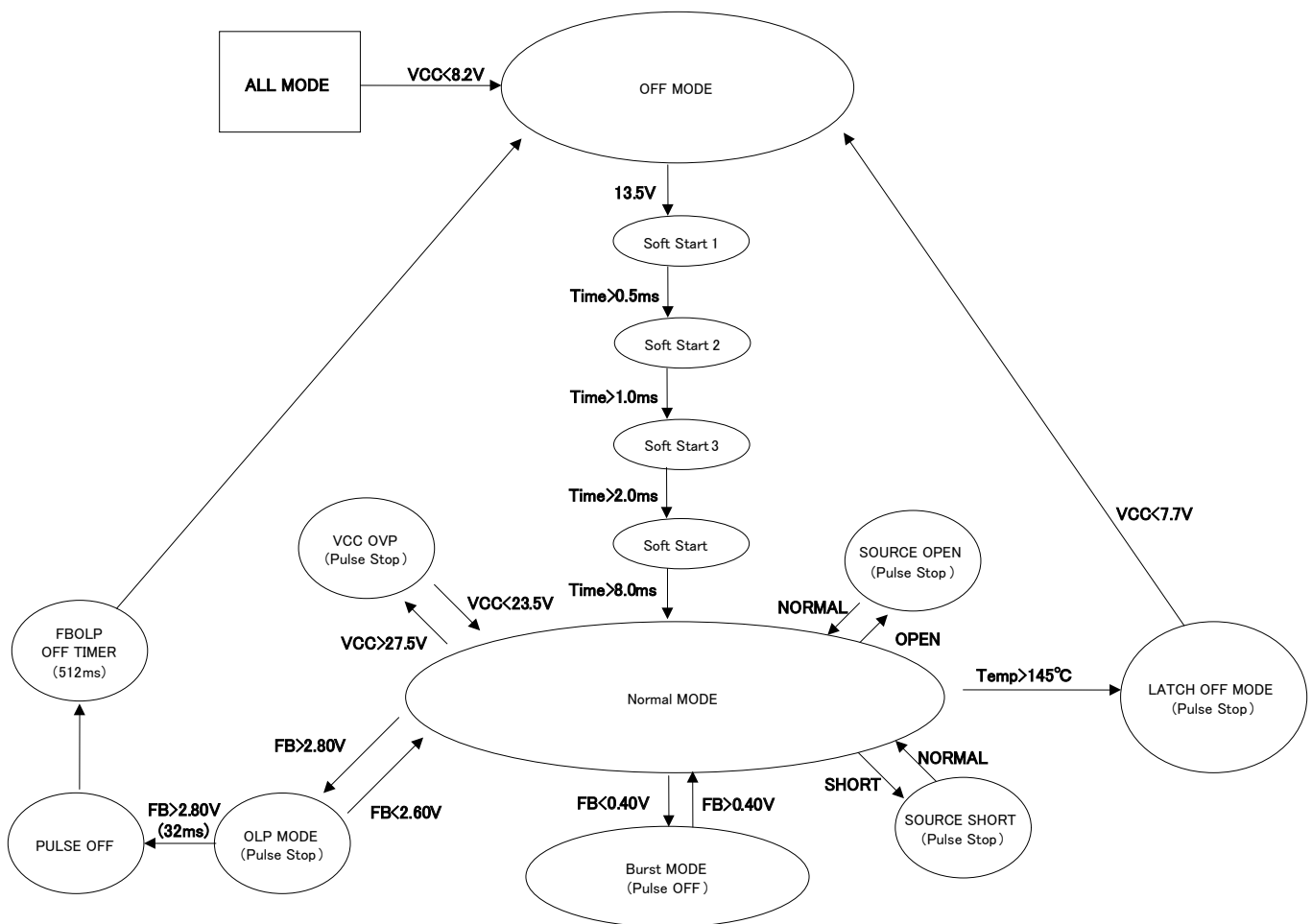

Figure 16. The sequence diagram

• Thermal loss

The thermal design should set operation for the following conditions.  
 (Since the temperature shown below is the guaranteed temperature, be sure to take a margin into account.)

1. The ambient temperature  $T_a$  must be 105°C or less.
2. The IC's loss must be within the allowable dissipation  $P_d$ .

The thermal abatement characteristics are as follows.  
 (PCB: 74.2 mm × 74.2mm × 1.6 mm, mounted on glass epoxy substrate)

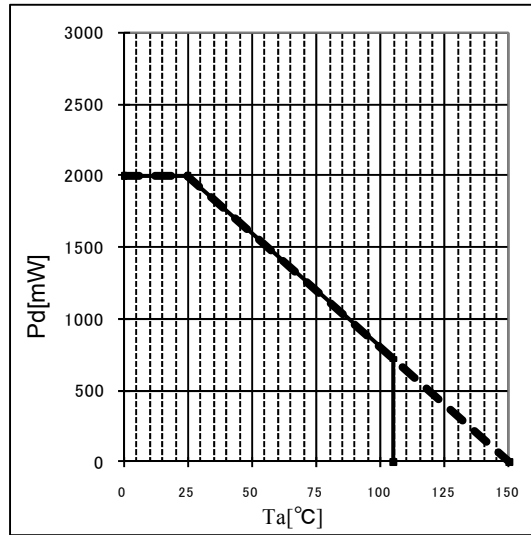
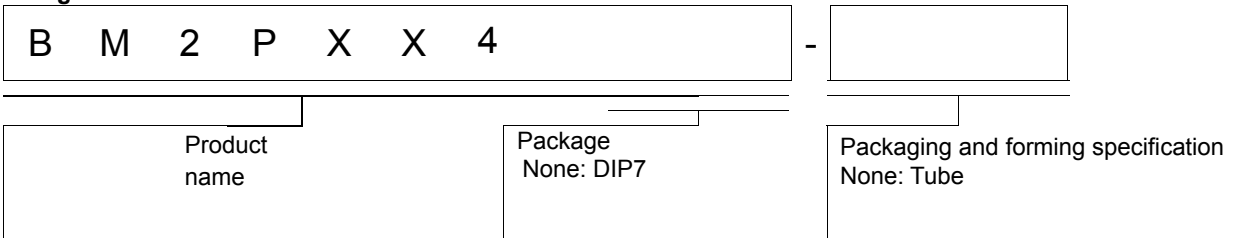

Figure 17. DIP7 Thermal Abatement Characteristics

●Ordering Information



●Physical Dimension Tape and Reel Information

DIP7

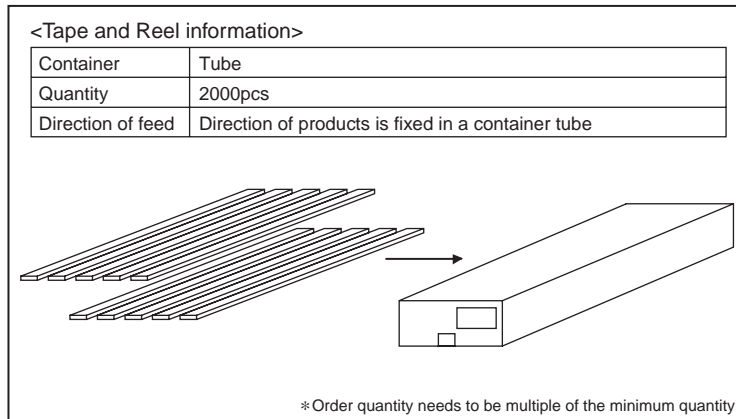
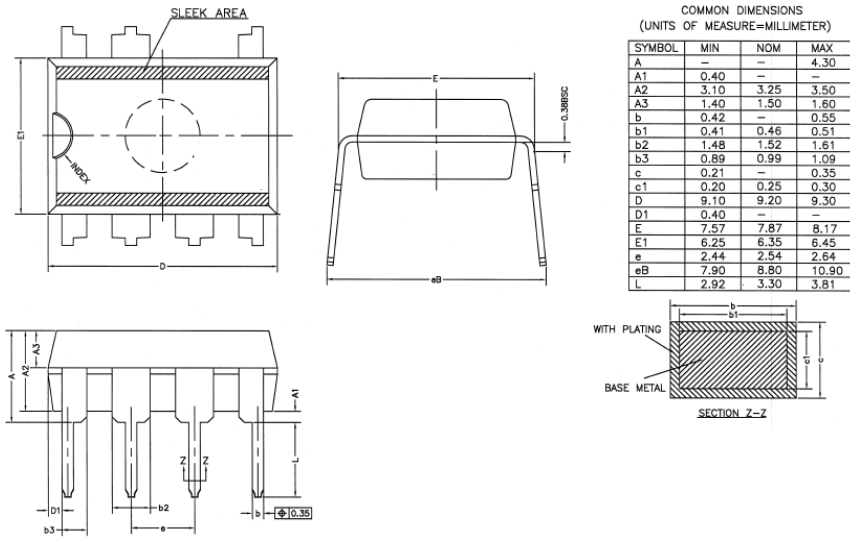

●Making Diagram

●Line-Up

DIP7

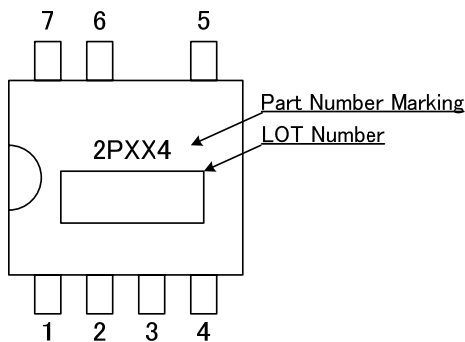

Product name (BM2PXX4)
BM2P014
BM2P034
BM2P054
BM2P094

- Use-related cautions
- (1) Absolute maximum ratings

Damage may occur if the absolute maximum ratings such as for applied voltage or operating temperature range are exceeded, and since the type of damage (short, open circuit, etc.) cannot be determined, in cases where a particular mode that may exceed the absolute maximum ratings is considered, use of a physical safety measure such as a fuse should be investigated.
  - (2) Power supply and ground lines

In the board pattern design, power supply and ground lines should be routed so as to achieve low impedance. If there are multiple power supply and ground lines, be careful with regard to interference caused by common impedance in the routing pattern. With regard to ground lines in particular, be careful regarding the separation of large current routes and small signal routes, including the external circuits. Also, with regard to all of the LSI's power supply pins, in addition to inserting capacitors between the power supply and ground pins, when using capacitors there can be problems such as capacitance losses at low temperature, so check thoroughly as to whether there are any problems with the characteristics of the capacitor to be used before determining constants.
  - (3) Ground potential

The ground pin's potential should be set to the minimum potential in relation to the operation mode.
  - (4) Pin shorting and attachment errors

When attaching ICs to the set board, be careful to avoid errors in the IC's orientation or position. If such attachment errors occur, the IC may become damaged. Also, damage may occur if foreign matter gets between pins, between a pin and a power supply line, or between ground lines.
  - (5) Operation in strong magnetic fields

Note with caution that these products may become damaged when used in a strong magnetic field.
  - (6) Input pins

In IC structures, parasitic elements are inevitably formed according to the relation to potential. When parasitic elements are active, they can interfere with circuit operations, can cause operation faults, and can even result in damage. Accordingly, be careful to avoid use methods that enable parasitic elements to become active, such as when a voltage that is lower than the ground voltage is applied to an input pin. Also, do not apply voltage to an input pin when there is no power supply voltage being applied to the IC. In fact, even if a power supply voltage is being applied, the voltage applied to each input pin should be either below the power supply voltage or within the guaranteed values in the electrical characteristics.
  - (7) External capacitors

When a ceramic capacitor is used as an external capacitor, consider possible reduction to below the nominal capacitance due to current bias and capacitance fluctuation due to temperature and the like before determining constants.
  - (8) Thermal design

The thermal design should fully consider allowable dissipation (Pd) under actual use conditions. Also, use these products within ranges that do not put output Tr beyond the rated voltage and ASO.
  - (9) Rush current

In a CMOS IC, momentary rush current may flow if the internal logic is undefined when the power supply is turned ON, so caution is needed with regard to the power supply coupling capacitance, the width of power supply and GND pattern wires, and how they are laid out.
  - (10) Handling of test pins and unused pins

Test pins and unused pins should be handled so as not to cause problems in actual use conditions, according to the descriptions in the function manual, application notes, etc. Contact us regarding pins that are not described.
  - (11) Document contents

Documents such as application notes are design documents used when designing applications, and as such their contents are not guaranteed. Before finalizing an application, perform a thorough study and evaluation, including for external parts.

#### Status of this document

The Japanese version of this document is formal specification. A customer may use this translation version only for a reference to help reading the formal version.

If there are any differences in translation version of this document formal version takes priority



# Notice

## ●General Precaution

- 1) Before you use our Products, you are requested to carefully read this document and fully understand its contents. ROHM shall not be in any way responsible or liable for failure, malfunction or accident arising from the use of any ROHM's Products against warning, caution or note contained in this document.
- 2) All information contained in this document is current as of the issuing date and subject to change without any prior notice. Before purchasing or using ROHM's Products, please confirm the latest information with a ROHM sales representative.

## ●Precaution on using ROHM Products

- 1) Our Products are designed and manufactured for application in ordinary electronic equipments (such as AV equipment, OA equipment, telecommunication equipment, home electronic appliances, amusement equipment, etc.). If you intend to use our Products in devices requiring extremely high reliability (such as medical equipment, transport equipment, traffic equipment, aircraft/spacecraft, nuclear power controllers, fuel controllers, car equipment including car accessories, safety devices, etc.) and whose malfunction or failure may cause loss of human life, bodily injury or serious damage to property ("Specific Applications"), please consult with the ROHM sales representative in advance. Unless otherwise agreed in writing by ROHM in advance, ROHM shall not be in any way responsible or liable for any damages, expenses or losses incurred by you or third parties arising from the use of any ROHM's Products for Specific Applications.
- 2) ROHM designs and manufactures its Products subject to strict quality control system. However, semiconductor products can fail or malfunction at a certain rate. Please be sure to implement, at your own responsibilities, adequate safety measures including but not limited to fail-safe design against the physical injury, damage to any property, which a failure or malfunction of our Products may cause. The following are examples of safety measures:
  - [a] Installation of protection circuits or other protective devices to improve system safety
  - [b] Installation of redundant circuits to reduce the impact of single or multiple circuit failure
- 3) Our Products are designed and manufactured for use under standard conditions and not under any special or extraordinary environments or conditions, as exemplified below. Accordingly, ROHM shall not be in any way responsible or liable for any damages, expenses or losses arising from the use of any ROHM's Products under any special or extraordinary environments or conditions. If you intend to use our Products under any special or extraordinary environments or conditions (as exemplified below), your independent verification and confirmation of product performance, reliability, etc. prior to use, must be necessary:
  - [a] Use of our Products in any types of liquid, including water, oils, chemicals, and organic solvents
  - [b] Use of our Products outdoors or in places where the Products are exposed to direct sunlight or dust
  - [c] Use of our Products in places where the Products are exposed to sea wind or corrosive gases, including Cl<sub>2</sub>, H<sub>2</sub>S, NH<sub>3</sub>, SO<sub>2</sub>, and NO<sub>2</sub>
  - [d] Use of our Products in places where the Products are exposed to static electricity or electromagnetic waves
  - [e] Use of our Products in proximity to heat-producing components, plastic cords, or other flammable items
  - [f] Sealing or coating our Products with resin or other coating materials
  - [g] Use of our Products without cleaning residue of flux (even if you use no-clean type fluxes, cleaning residue of flux is recommended); or Washing our Products by using water or water-soluble cleaning agents for cleaning residue after soldering
  - [h] Use of the Products in places subject to dew condensation
- 4) The Products are not subject to radiation-proof design.
- 5) Please verify and confirm characteristics of the final or mounted products in using the Products.
- 6) In particular, if a transient load (a large amount of load applied in a short period of time, such as pulse) is applied, confirmation of performance characteristics after on-board mounting is strongly recommended. Avoid applying power exceeding normal rated power; exceeding the power rating under steady-state loading condition may negatively affect product performance and reliability.
- 7) De-rate Power Dissipation (Pd) depending on Ambient temperature (Ta). When used in sealed area, confirm the actual ambient temperature.
- 8) Confirm that operation temperature is within the specified range described in the product specification.
- 9) ROHM shall not be in any way responsible or liable for failure induced under deviant condition from what is defined in this document.

**●Precaution for Mounting / Circuit board design**

- 1) When a highly active halogenous (chlorine, bromine, etc.) flux is used, the residue of flux may negatively affect product performance and reliability.
- 2) In principle, the reflow soldering method must be used; if flow soldering method is preferred, please consult with the ROHM representative in advance.

For details, please refer to ROHM Mounting specification

**●Precautions Regarding Application Examples and External Circuits**

- 1) If change is made to the constant of an external circuit, please allow a sufficient margin considering variations of the characteristics of the Products and external components, including transient characteristics, as well as static characteristics.
- 2) You agree that application notes, reference designs, and associated data and information contained in this document are presented only as guidance for Products use. Therefore, in case you use such information, you are solely responsible for it and you must exercise your own independent verification and judgment in the use of such information contained in this document. ROHM shall not be in any way responsible or liable for any damages, expenses or losses incurred by you or third parties arising from the use of such information.

**●Precaution for Electrostatic**

This Product is electrostatic sensitive product, which may be damaged due to electrostatic discharge. Please take proper caution in your manufacturing process and storage so that voltage exceeding the Products maximum rating will not be applied to Products. Please take special care under dry condition (e.g. Grounding of human body / equipment / solder iron, isolation from charged objects, setting of Ionizer, friction prevention and temperature / humidity control).

**●Precaution for Storage / Transportation**

- 1) Product performance and soldered connections may deteriorate if the Products are stored in the places where:
  - [a] the Products are exposed to sea winds or corrosive gases, including Cl<sub>2</sub>, H<sub>2</sub>S, NH<sub>3</sub>, SO<sub>2</sub>, and NO<sub>2</sub>
  - [b] the temperature or humidity exceeds those recommended by ROHM
  - [c] the Products are exposed to direct sunshine or condensation
  - [d] the Products are exposed to high Electrostatic
- 2) Even under ROHM recommended storage condition, solderability of products out of recommended storage time period may be degraded. It is strongly recommended to confirm solderability before using Products of which storage time is exceeding the recommended storage time period.
- 3) Store / transport cartons in the correct direction, which is indicated on a carton with a symbol. Otherwise bent leads may occur due to excessive stress applied when dropping of a carton.
- 4) Use Products within the specified time after opening a humidity barrier bag. Baking is required before using Products of which storage time is exceeding the recommended storage time period.

**●Precaution for Product Label**

QR code printed on ROHM Products label is for ROHM's internal use only.

**●Precaution for Disposition**

When disposing Products please dispose them properly using an authorized industry waste company.

**●Precaution for Foreign Exchange and Foreign Trade act**

Since our Products might fall under controlled goods prescribed by the applicable foreign exchange and foreign trade act, please consult with ROHM representative in case of export.

**●Precaution Regarding Intellectual Property Rights**

- 1) All information and data including but not limited to application example contained in this document is for reference only. ROHM does not warrant that foregoing information or data will not infringe any intellectual property rights or any other rights of any third party regarding such information or data. ROHM shall not be in any way responsible or liable for infringement of any intellectual property rights or other damages arising from use of such information or data.:
- 2) No license, expressly or implied, is granted hereby under any intellectual property rights or other rights of ROHM or any third parties with respect to the information contained in this document.

●Other Precaution

- 1) The information contained in this document is provided on an "as is" basis and ROHM does not warrant that all information contained in this document is accurate and/or error-free. ROHM shall not be in any way responsible or liable for any damages, expenses or losses incurred by you or third parties resulting from inaccuracy or errors of or concerning such information.
- 2) This document may not be reprinted or reproduced, in whole or in part, without prior written consent of ROHM.
- 3) The Products may not be disassembled, converted, modified, reproduced or otherwise changed without prior written consent of ROHM.
- 4) In no event shall you use in any way whatsoever the Products and the related technical information contained in the Products or this document for any military purposes, including but not limited to, the development of mass-destruction weapons.
- 5) The proper names of companies or products described in this document are trademarks or registered trademarks of ROHM, its affiliated companies or third parties.