

SML-81 series

3412 (1305)
3.4 × 1.25mm (t=1.1mm)

Features

- Reverse-mount available type



Specifications

Part No.	Chip Structure	Emitting Color	Absolute Maximum Ratings (Ta=25°C)					Electrical and Optical Characteristics (Ta=25°C)															
			Power Dissipation Pd (mW)	Forward Current IF (mA)	Peak Forward Current IFP (mA)	Reverse Voltage VR (V)	Operating Temperature Topr (°C)	Storage Temperature Tstg (°C)	Forward Voltage VF (V)		Reverse Current IR (μA)		Dominant Wavelength λD (nm)			Luminous Intensity Iv (mcd)							
SML-811VT(A)	AlGaInP	Red	62	25	100*2	5	-40 to +85	-40 to +100	1.95	10	5	625	630	636	10	11.2	22.4	10					
SML-811UT(A)																			615	620	625	11	22
SML-811DT(A)		Orange																	602	605	608	14	28
SML-811WT(A)																			587	590	593	9	18
SML-811YT(A)		Yellow																	584	587	590	14	40
SML-812MT	GaP	Yellowish Green	65	60*1	4	-30 to +85	-40 to +85	2.1	20	4	569	572	575	20	5.6	16	20						
SML-810MT																		567	570	573	22	56	
SML813BC8T	InGaN	Blue	87	20	100*2	5	-40 to +85	-40 to +100	3.3	20	5	464	470	476	22	56	20						
SML812BCT			80															-30 to +85	-40 to +85	20			

* 1: Duty 1/5, 200Hz / * 2: Duty 1/10, 1kHz / * 3: Reference

Dimensions

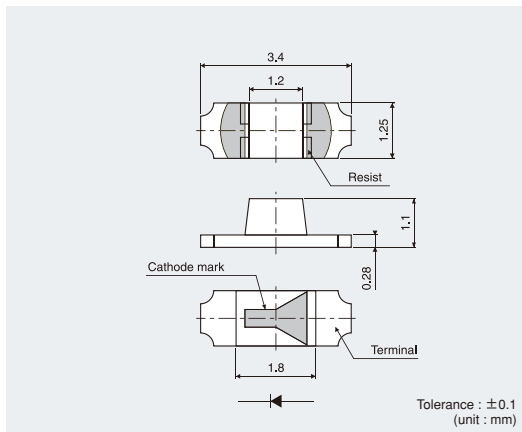

Recommended Solder Pattern

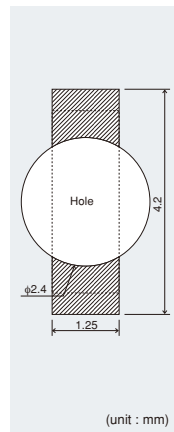

Viewing Angle

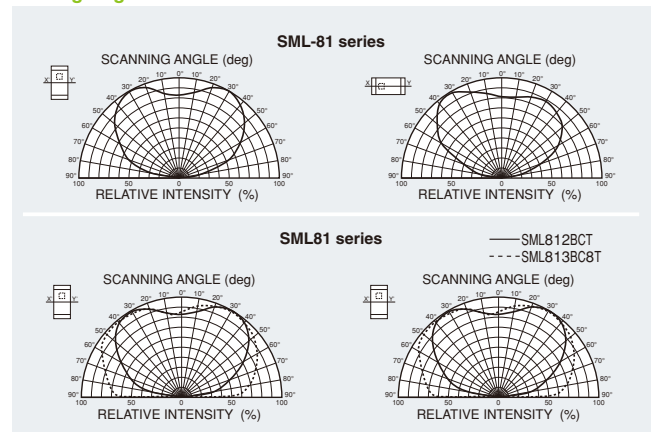

Electrical Characteristics Curves

Forward Current-Forward Voltage

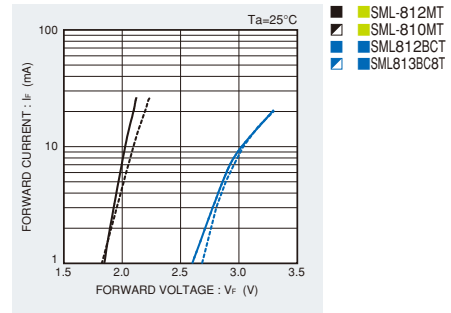
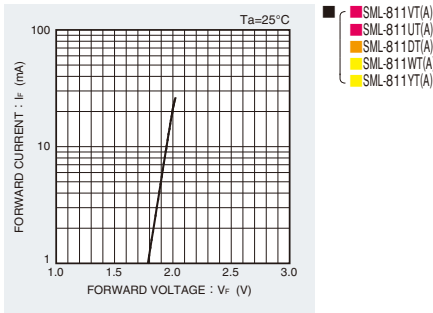

Luminous Intensity-Atmosphere Temperature

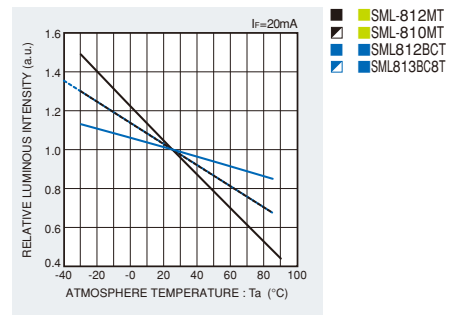
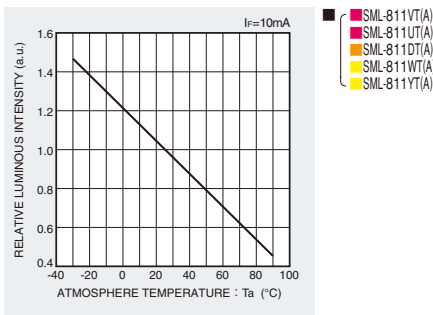

Luminous Intensity-Forward Current

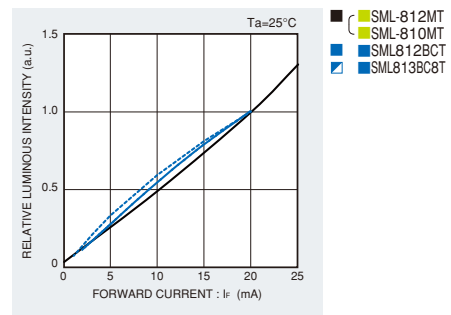
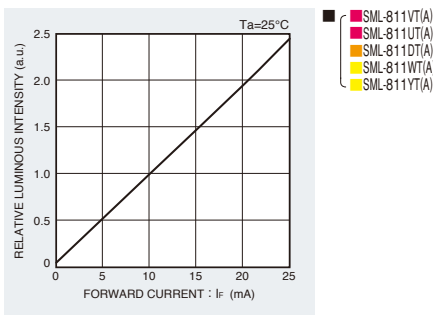

Derating

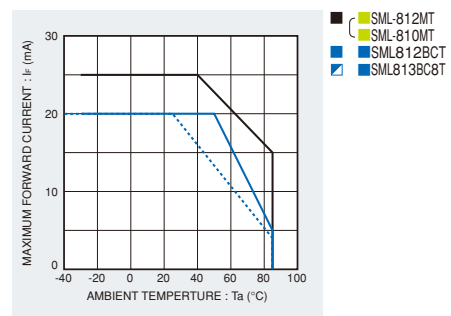
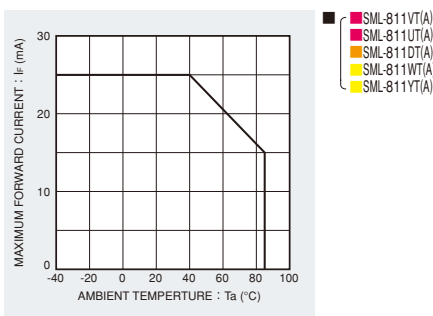

SML-81 series

Rank Reference of Brightness

Red (V, U)

Package structure	Package size	Height (mm)	Luminous Intensity (mcd) I _f (mA)	AG	AH	AJ	AK	AL	AM	AN	AP	AQ	AR	AS	AT	AU	AV	AW	AX
				9.0 to 11.2	11.2 to 14	14 to 18	18 to 22.4	22.4 to 28	28 to 35.5	35.5 to 45	45 to 56	56 to 71	71 to 90	90 to 112	112 to 140	140 to 180	180 to 224	224 to 280	280 to 355
Reverse Mount	34125	1.1	10	SML-811VT(A)* SML-811UT(A)*															

Orange (D)

Package structure	Package size	Height (mm)	Luminous Intensity (mcd) I _f (mA)	AG	AH	AJ	AK	AL	AM	AN	AP	AQ	AR	AS	AT	AU	AV	AW	AX
				9.0 to 11.2	11.2 to 14	14 to 18	18 to 22.4	22.4 to 28	28 to 35.5	35.5 to 45	45 to 56	56 to 71	71 to 90	90 to 112	112 to 140	140 to 180	180 to 224	224 to 280	280 to 355
Reverse Mount	34125	1.1	10	SML-811DT(A)*															

Yellow (W, Y)

Package structure	Package size	Height (mm)	Luminous Intensity (mcd) I _f (mA)	AG	AH	AJ	AK	AL	AM	AN	AP	AQ	AR	AS	AT	AU	AV	AW	AX
				9.0 to 11.2	11.2 to 14	14 to 18	18 to 22.4	22.4 to 28	28 to 35.5	35.5 to 45	45 to 56	56 to 71	71 to 90	90 to 112	112 to 140	140 to 180	180 to 224	224 to 280	280 to 355
Reverse Mount	34125	1.1	10	SML-811WT(A)* SML-811YT(A)*															

Green (M)

Package structure	Package size	Height (mm)	Luminous Intensity (mcd) I _f (mA)	G	H	J	K	L	M	N	P	Q	R	S	T	U	V	W	X
				1.0 to 1.6	1.6 to 2.5	2.5 to 4.0	4.0 to 6.3	6.3 to 10	10 to 16	16 to 25	25 to 40	40 to 63	63 to 100	100 to 160	160 to 250	250 to 400	400 to 630	630 to 1000	1000 to 1600
Reverse Mount	34125	1.1	10	SML-810MT* SML-812MT*															

Blue (B)

Package structure	Package size	Height (mm)	Luminous Intensity (mcd) I _f (mA)	G	H	J	K	L	M	N	P	Q	R	S	T	U	V	W	X
				0.9 to 1.4	1.4 to 2.2	2.2 to 3.6	3.6 to 5.6	5.6 to 9	9 to 14	14 to 22	22 to 36	36 to 56	56 to 90	90 to 140	140 to 220	220 to 360	360 to 560	560 to 900	900 to 1400
Reverse Mount	34125	1.1	20	SML813BC8T SML812BCT															

* Please note that the brightness of some products may fall between ranks (half rank).
** Brightness on specification sheet include tolerance of within ±10%.

Part No. Construction

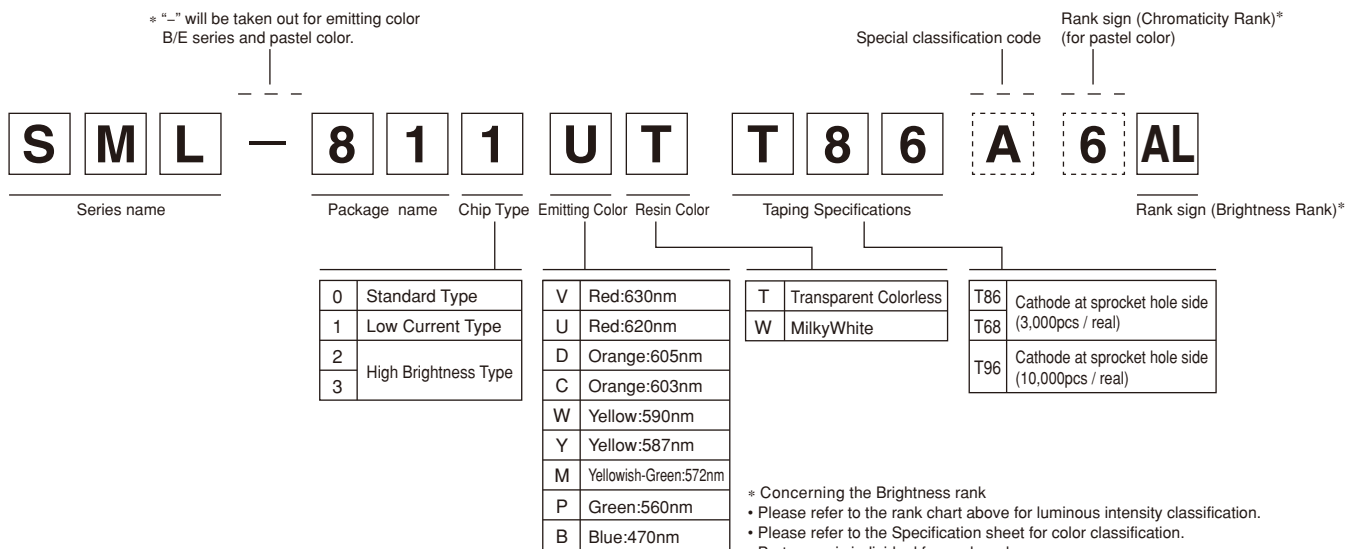

* Concerning the Brightness rank
 • Please refer to the rank chart above for luminous intensity classification.
 • Please refer to the Specification sheet for color classification.
 • Part name is individual for each rank.
 • When shipped as sample, the part name will be a representative part name.
 General products are free of ranks. Please contact sales if rank appointment is needed.
 * Please refer to the Specification sheet about Taping specification.

Packing Specification

ROHM LED products are being shipped with desiccant (silica gel) concluded in moisture-proof bags.
 Pasting the moisture sensitive label on the outer surface of the moisture-proof bags or enclosing the humidity indication card inside the bag is available upon request.
 Please contact the nearest sales office or distributor if necessary.

Notes

- 1) The information contained herein is subject to change without notice.
- 2) Before you use our Products, please contact our sales representative and verify the latest specifications :
- 3) Although ROHM is continuously working to improve product reliability and quality, semiconductors can break down and malfunction due to various factors.
Therefore, in order to prevent personal injury or fire arising from failure, please take safety measures such as complying with the derating characteristics, implementing redundant and fire prevention designs, and utilizing backups and fail-safe procedures. ROHM shall have no responsibility for any damages arising out of the use of our Products beyond the rating specified by ROHM.
- 4) Examples of application circuits, circuit constants and any other information contained herein are provided only to illustrate the standard usage and operations of the Products. The peripheral conditions must be taken into account when designing circuits for mass production.
- 5) The technical information specified herein is intended only to show the typical functions of and examples of application circuits for the Products. ROHM does not grant you, explicitly or implicitly, any license to use or exercise intellectual property or other rights held by ROHM or any other parties. ROHM shall have no responsibility whatsoever for any dispute arising out of the use of such technical information.
- 6) The Products are intended for use in general electronic equipment (i.e. AV/OA devices, communication, consumer systems, gaming/entertainment sets) as well as the applications indicated in this document.
- 7) The Products specified in this document are not designed to be radiation tolerant.
- 8) For use of our Products in applications requiring a high degree of reliability (as exemplified below), please contact and consult with a ROHM representative : transportation equipment (i.e. cars, ships, trains), primary communication equipment, traffic lights, fire/crime prevention, safety equipment, medical systems, servers, solar cells, and power transmission systems.
- 9) Do not use our Products in applications requiring extremely high reliability, such as aerospace equipment, nuclear power control systems, and submarine repeaters.
- 10) ROHM shall have no responsibility for any damages or injury arising from non-compliance with the recommended usage conditions and specifications contained herein.
- 11) ROHM has used reasonable care to ensure the accuracy of the information contained in this document. However, ROHM does not warrant that such information is error-free, and ROHM shall have no responsibility for any damages arising from any inaccuracy or misprint of such information.
- 12) Please use the Products in accordance with any applicable environmental laws and regulations, such as the RoHS Directive. For more details, including RoHS compatibility, please contact a ROHM sales office. ROHM shall have no responsibility for any damages or losses resulting from non-compliance with any applicable laws or regulations.
- 13) When providing our Products and technologies contained in this document to other countries, you must abide by the procedures and provisions stipulated in all applicable export laws and regulations, including without limitation the US Export Administration Regulations and the Foreign Exchange and Foreign Trade Act.
- 14) This document, in part or in whole, may not be reprinted or reproduced without prior consent of ROHM.



Thank you for your accessing to ROHM product informations.
More detail product informations and catalogs are available, please contact us.

ROHM Customer Support System

<http://www.rohm.com/contact/>