

DATA SHEET

SKY13346-368LF: 0.5-2.5 GHz SP3T Switch

Applications

- 802.11 b/g WLANs
- Bluetooth

Features

- Broadband frequency range: 0.5-2.5 GHz
- Low insertion loss: 0.5 dB @ 2.5 GHz
- High isolation: 25 dB up to 2.5 GHz
- Positive low voltage control: 1.8 to 5.0 V
- Small, QFN (12-pin, 2 x 2 mm) package (MSL1, 260 °C per JEDEC J-STD-020)

NEW



Skyworks Green™ products are RoHS (Restriction of Hazardous Substances)-compliant, conform to the EIA/EICTA/JEITA Joint Industry Guide (JIG) Level A guidelines, are halogen free according to IEC-61249-2-21, and contain <1,000 ppm antimony trioxide in polymeric materials.

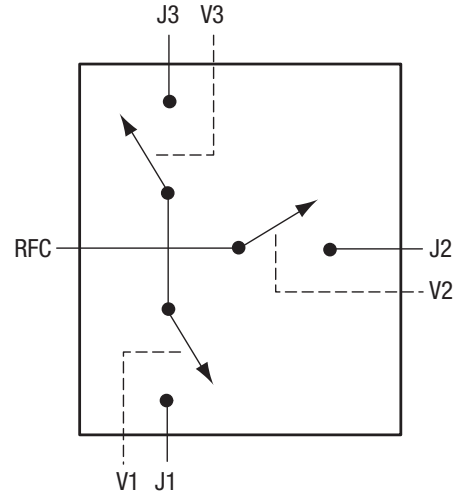

Figure 1. SKY13346-368LF Block Diagram

Description

The SKY13346-368LF is a GaAs pHEMT, single-pole, triple-throw (SP3T) switch. The high linearity performance and low insertion loss makes the device an ideal choice for WLAN (802.11 b/g) and Bluetooth® applications in the 2.4 to 2.5 GHz frequency range.

The SKY13346-368LF SP3T switch is provided in a compact Quad Flat No-Lead (QFN) 2 x 2 mm package. A functional block diagram is shown in Figure 1. The pin configuration and package are shown in Figure 2. Signal pin assignments and functional pin descriptions are provided in Table 1.

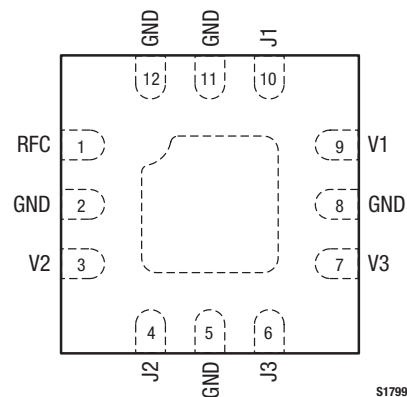

Figure 2. SKY13346-368LF Pinout – 12-Pin QFN (Top View)

Table 1. SKY13346-368LF Signal Descriptions

Pin #	Name	Description	Pin #	Name	Description
1	RFC	RF common (antenna) port. DC blocking capacitor required.	7	V3	DC control voltage 3. Connects RFC to J3 with logic high (1.8 to 5.0 V)
2	GND	Ground	8	GND	Ground
3	V2	DC control voltage 2. Connects RFC to J2 with logic high (1.8 to 5.0 V)	9	V1	DC control voltage 1. Connects RFC to J1 with logic high (1.8 to 5.0 V)
4	J2	RF port 2. DC blocking capacitor required.	10	J1	RF port 1. DC blocking capacitor required.
5	GND	Ground	11	GND	Ground
6	J3	RF port 3.	12	GND	Ground

Note: Exposed pad must be grounded.

Table 2. SKY13346-368LF Absolute Maximum Ratings

Parameter	Symbol	Minimum	Typical	Maximum	Units
Control voltage	V _{CTL}		8		V
Input power (V _{CTL} = 3 to 5 V)	P _{IN}		+33		dBm
Storage temperature	T _{STG}	-40		+125	°C
Operating temperature	T _{OP}	-40		+85	°C

Note: Exposure to maximum rating conditions for extended periods may reduce device reliability. There is no damage to device with only one parameter set at the limit and all other parameters set at or below their nominal value. Exceeding any of the limits listed here may result in permanent damage to the device.

CAUTION: Although this device is designed to be as robust as possible, Electrostatic Discharge (ESD) can damage this device. This device must be protected at all times from ESD. Static charges may easily produce potentials of several kilovolts on the human body or equipment, which can discharge without detection. Industry-standard ESD precautions should be used at all times.

Functional Description

Switching is controlled by three control voltage inputs: V1, V2, and V3. Depending on the logic voltage level applied to the control pins, the RFC (RF common) pin is connected to one of three switched RF outputs (J1, J2, or J3) through a low insertion path, while the path between the RFC pin and the other RF pins are in a high isolation state.

External DC blocking capacitors are required on the RF paths.

Electrical and Mechanical Specifications

The absolute maximum ratings of the SKY13346-368LF are provided in Table 2. Electrical specifications are provided in Table 3.

The state of the SKY13346-368LF is determined by the logic provided in Table 4.

Typical performance characteristics of the SKY13346-368LF are illustrated in Figures 3 through 11.

Table 3. SKY13346-368LF Electrical Specifications (Note 1)

($V_{CTL} = 0\text{ V to }2.85\text{ V}$, $T_{OP} = +25\text{ }^\circ\text{C}$, $P_{IN} = 0\text{ dBm}$, Characteristic Impedance [Z_0] = $50\ \Omega$, $C_{BL} = 56\text{ pF}$, Unless Otherwise Noted)

Parameter	Symbol	Test Condition	Min	Typical	Max	Units
Insertion loss (RFC to J1, J2, J3)	IL	0.5 to 1.0 GHz		0.40	0.50	dB
		1.0 to 2.0 GHz		0.45	0.55	dB
		2.0 to 2.5 GHz		0.50	0.60	dB
Isolation: RFC to J1, J2, J3 RFC to J1, J2 RFC to J1, J2 RFC to J3 RFC to J3	ISO	0.5 to 1.0 GHz	25	28		dB
		1.0 to 2.0 GHz	24	27		dB
		2.0 to 2.5 GHz	25	28		dB
		1.0 to 2.0 GHz	22	25		dB
		2.0 to 2.5 GHz	22	25		dB
Return loss (RFC to J1, J2, J3)	IS111	0.5 to 2.5 GHz		25		dB
3 rd Order Input Intercept Point	IIP3	1, 2, and 2.5 GHz, $\Delta F = 1\text{ MHz}$, $P_{IN} = +17\text{ dBm/ tone}$		+47		dBm
Input 1 dB compression point	P1dB	1, 2, and 2.5 GHz		+30		dBm
Error Vector Magnitude	EVM	2.4 to 2.5 GHz, 802.11g, 54 Mbps EVM, $P_{IN} = +23\text{ dBm}$		3		%
2 nd harmonic	2fo	1, 2, and 2.5 GHz		+63		dBc
3 rd harmonic	3fo	1, 2, and 2.5 GHz		+60		dBc
Video feedthrough				50		mV
Switching rise time		10/90% RF		50		ns
Switching fall time		90/10% RF		25		ns
Switching on time		50% control to 10/90% RF		55		ns
Switching off time		50% control to 90/10% RF		30		ns
Power Supply						
Control voltage: High Low	V_{CTL}		1.8		5	V
			0		0.2	V
Control current: High Low	I_{CTL}	$V_{CTL} = 1.8\text{ to }5.0\text{ V}$ $V_{CTL} = 0\text{ to }0.2\text{ V}$		10		μA
				5		μA

Note 1: Performance is guaranteed only under the conditions listed in this Table.

Table 4. SKY13346-368LF Truth Table

V1 (Pin 9)	V2 (Pin 3)	V3 (Pin 7)	RFC to J1	RFC to J2	RFC to J3
1	0	0	Insertion loss	Isolation	Isolation
0	1	0	Isolation	Insertion loss	Isolation
0	0	1	Isolation	Isolation	Insertion loss

Note: 1 = 1.8 to 5.0 V

0 = 0 to 0.2 V

Any state other than described in this Table places the switch into an undefined state.

Typical Performance Characteristics

($V_{CTL} = 0\text{ V}$ to 2.85 V , $T_{OP} = +25\text{ }^\circ\text{C}$, $P_{IN} = 0\text{ dBm}$, Characteristic Impedance [Z_0] = $50\ \Omega$, $C_{BL} = 56\text{ pF}$, Unless Otherwise Noted)

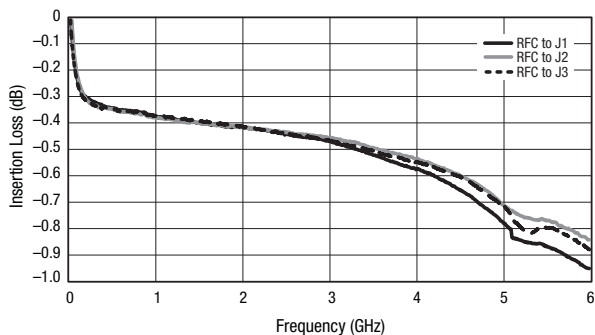

Figure 3. Insertion Loss vs Frequency

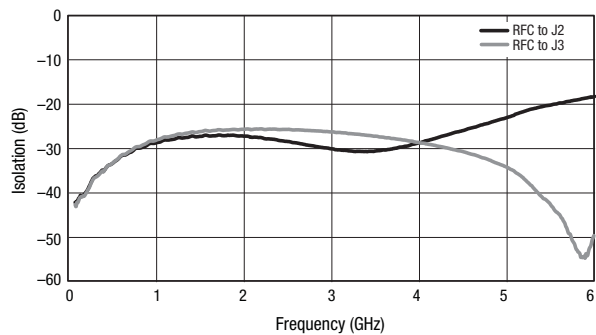

Figure 4. Isolation vs Frequency (RFC to J1 Insertion Loss State)

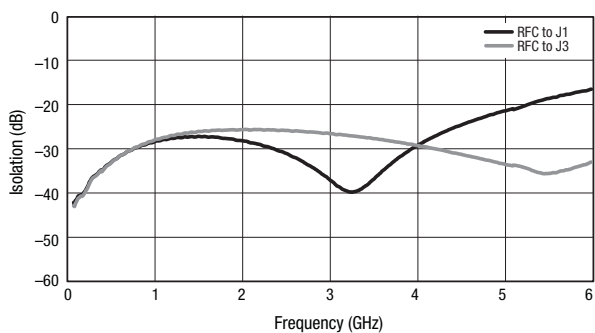

Figure 5. Isolation vs Frequency (RFC to J2 Insertion Loss State)

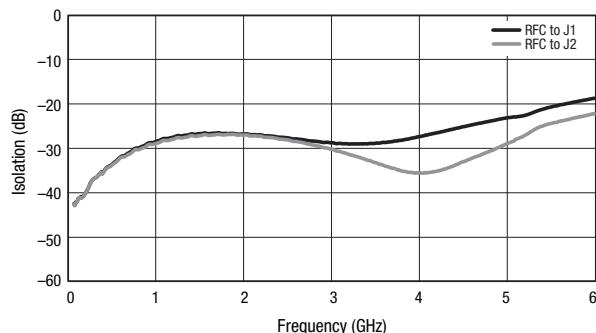

Figure 6. Isolation vs Frequency (RFC to J3 Insertion Loss State)

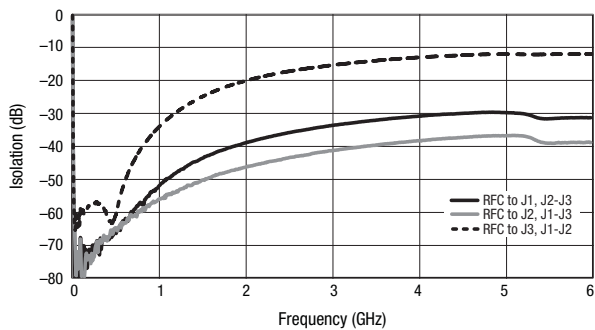

Figure 7. Port to Port Isolation vs Frequency (Off Ports to Off Ports)

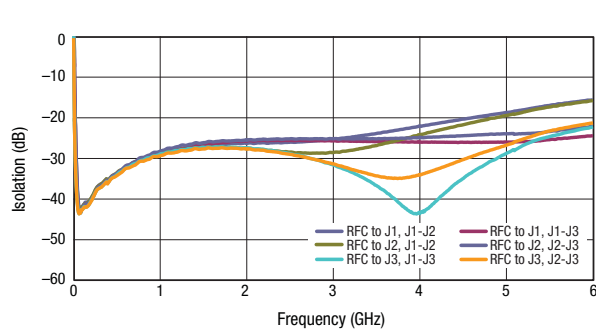

Figure 8. Port to Port Isolation vs Frequency (Insertion Loss Ports to Off Ports)

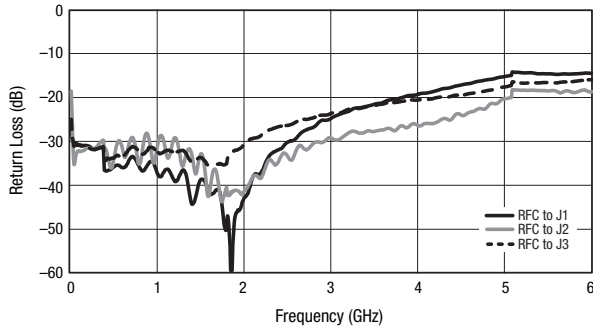

Figure 9. Input Return Loss vs Frequency

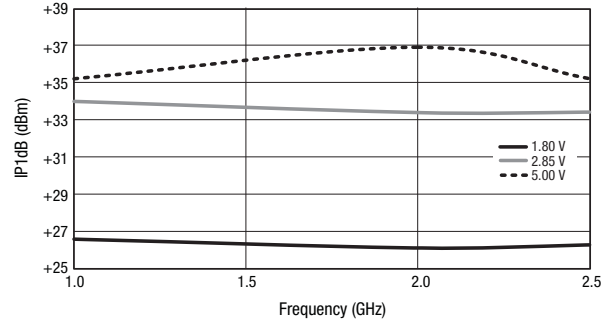

Figure 10. Input 1 dB Compression Point vs Frequency

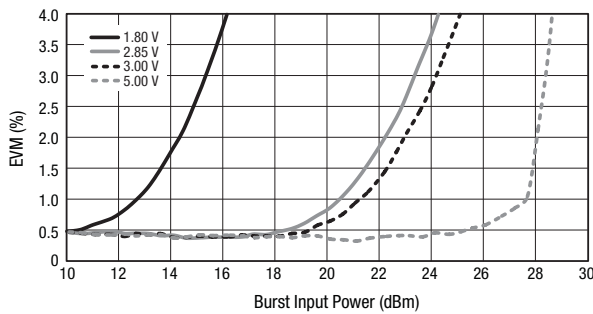

Figure 11. EVM vs Burst Input Power Over Voltage
(F = 2.5 GHz, 802.11g, 54 Mbps, 64 QAM)

Evaluation Board Description

The SKY13346-368LF Evaluation Board is used to test the performance of the SKY13346-368LF SP3T Switch. An Evaluation Board schematic diagram is provided in Figure 12. Table 5 provides the Bill of Materials (BOM) list for Evaluation Board components. An assembly drawing for the Evaluation Board is shown in Figure 13.

Package Dimensions

The PCB layout footprint for the SKY13346-368LF is provided in Figure 14. Typical case markings are shown in Figure 15. Package dimensions for the 12-pin QFN are shown in Figure 16, and tape and reel dimensions are provided in Figure 17.

Package and Handling Information

Instructions on the shipping container label regarding exposure to moisture after the container seal is broken must be followed. Otherwise, problems related to moisture absorption may occur when the part is subjected to high temperature during solder assembly.

THE SKY13346-368LF is rated to Moisture Sensitivity Level 1 (MSL1) at 260 °C. It can be used for lead or lead-free soldering.

Care must be taken when attaching this product, whether it is done manually or in a production solder reflow environment. Production quantities of this product are shipped in a standard tape and reel format. For packaging details, refer to the Skyworks Application Note, *Discrete Devices and IC Switch/Attenuators Tape and Reel Package Orientation*, document number 200083.

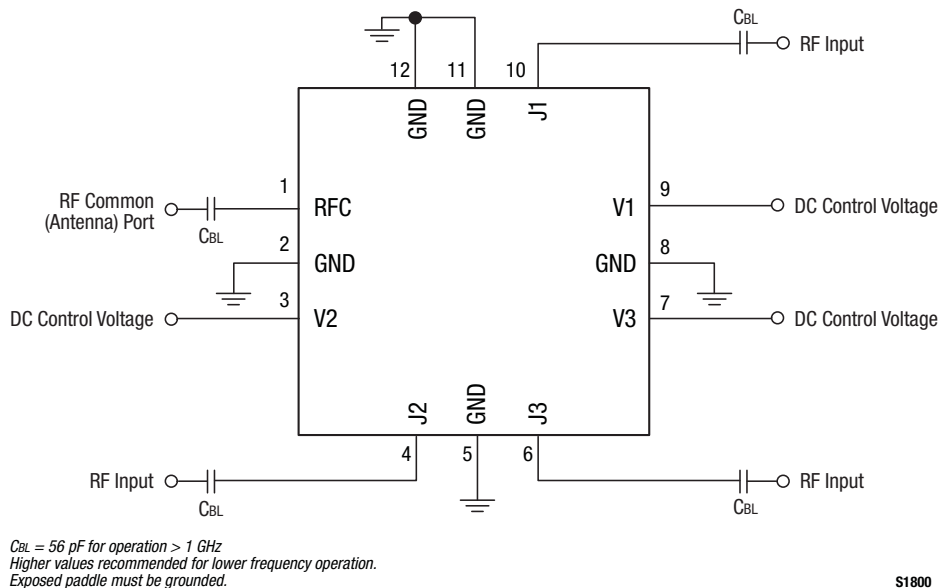

Figure 12. SKY13346-368LF Evaluation Board Schematic

Table 5. SKY13346-358LF Evaluation Board Bill of Materials

Component	Value	Size	Manufacturer/Part Series
CBL	56 pF	0402	Murata GRM Series

Note: Blocking capacitors are required on all RF ports for proper functionality. Value of DC blocking capacitor determines lower frequency operation.

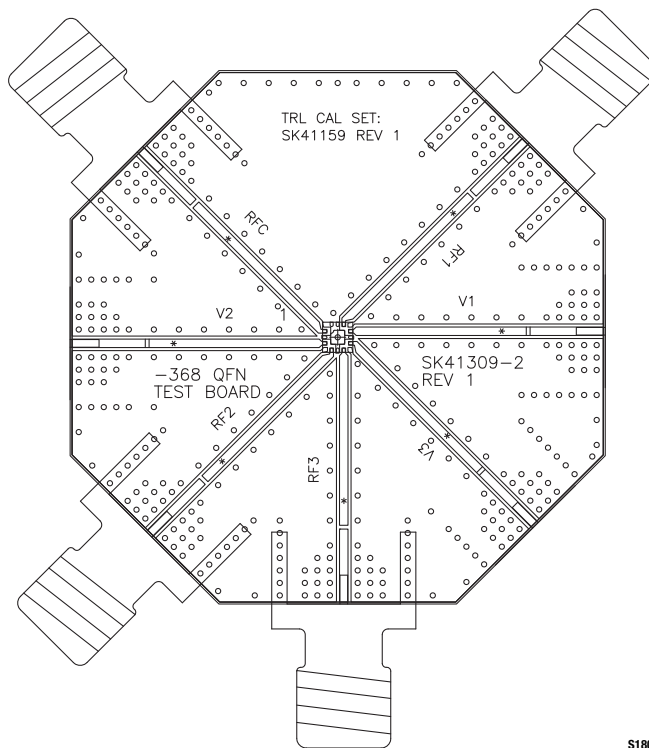
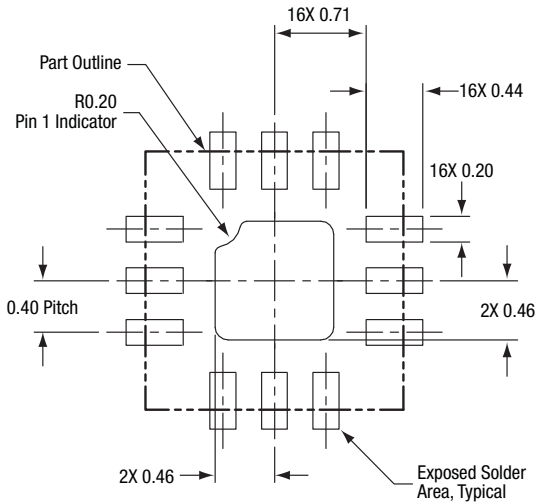

Figure 13. SKY13346-368LF Evaluation Board Assembly Diagram



All measurements in millimeters

S1802

Figure 14. SKY13346-368LF PCB Layout Footprint (Top View)

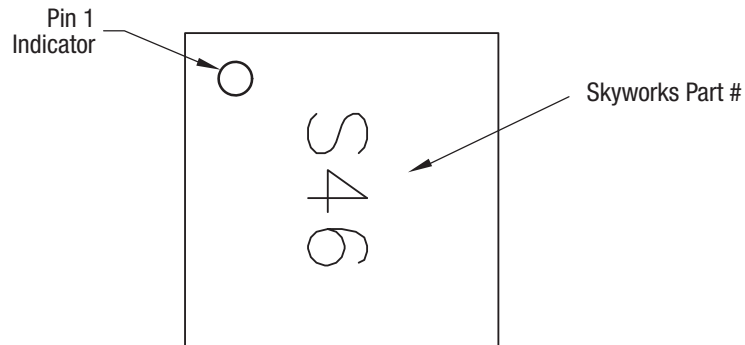
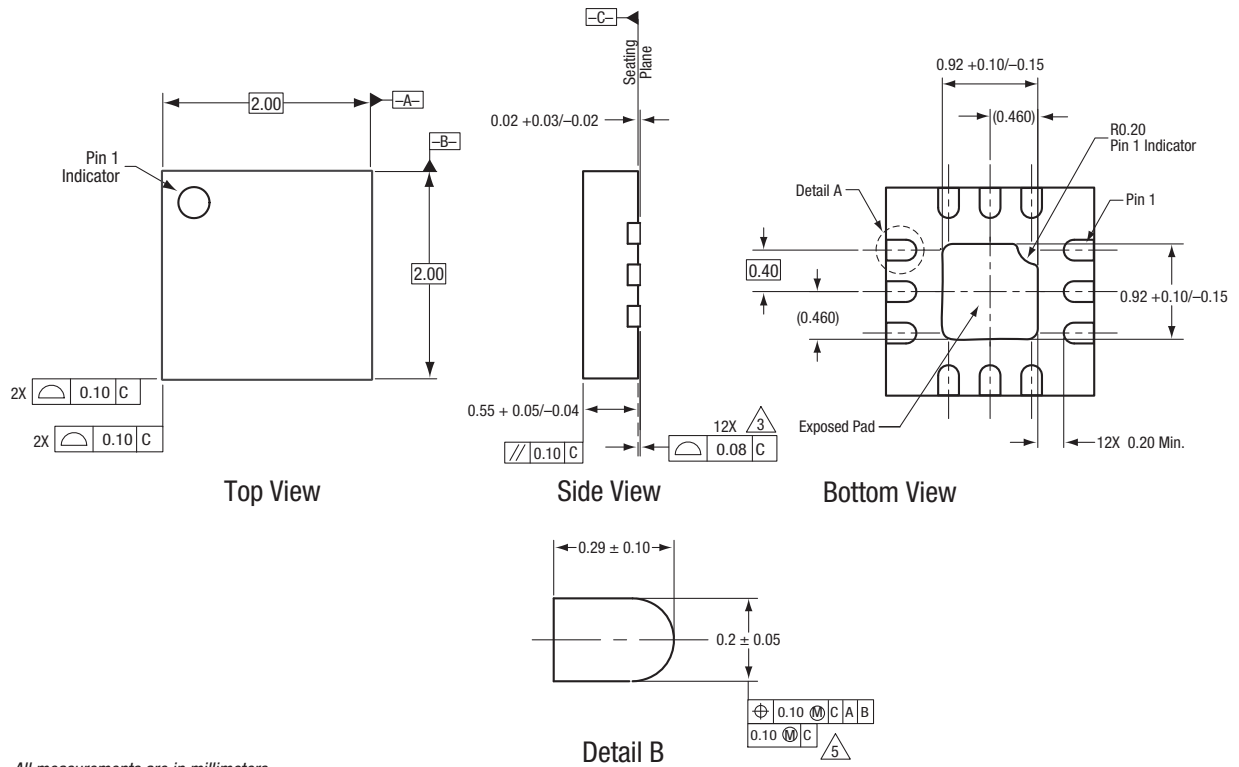

Figure 15. Typical Case Markings (Top View)



All measurements are in millimeters.
 Dimensioning and tolerancing according to ASME Y14.5M-1994.
 Coplanarity applies to the terminals and all other bottom surface metalization.
 Plating requirement per source control drawing (SCD) 2504.
 Dimension applies to metalized terminal and is measured between 0.15 and 0.30 mm from terminal tip.

S1731

Figure 16. SKY13346-368LF 12-Pin QFN Package Dimensions

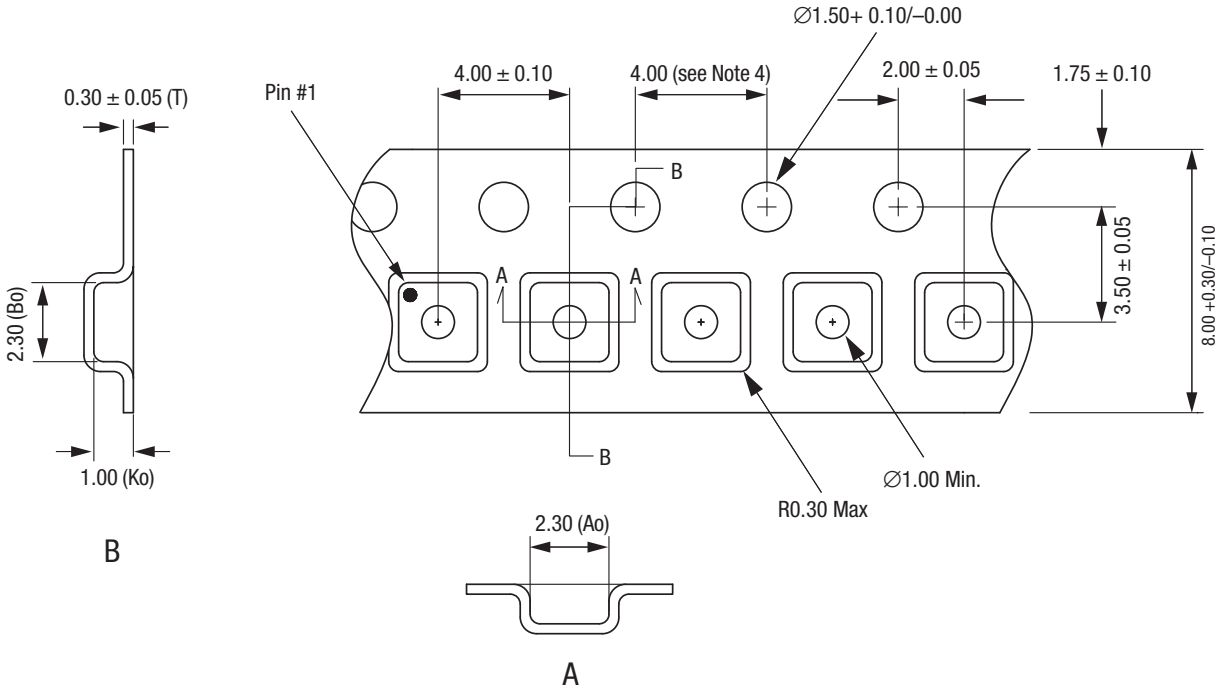

- Notes:
1. Carrier tape: black conductive polystyrene.
 2. Cover tape material: transparent conductive HSA.
 3. Cover tape size: 5.40 mm width.
 4. Ten sprocket hole pitch cumulative tolerance = ± 0.20 mm.
 5. All measurements are in millimeters.

S1601

Figure 17. SKY13346-368LF Tape and Reel Dimensions

Ordering Information

Model Name	Manufacturing Part Number	Evaluation Kit Part Number
SKY13346-368LF SP3T Switch	SKY13346-368LF (Pb-free and Green package)	SK41309-2, rev. 1

Copyright © 2009 Skyworks Solutions, Inc. All Rights Reserved.

Information in this document is provided in connection with Skyworks Solutions, Inc. ("Skyworks") products or services. These materials, including the information contained herein, are provided by Skyworks as a service to its customers and may be used for informational purposes only by the customer. Skyworks assumes no responsibility for errors or omissions in these materials or the information contained herein. Skyworks may change its documentation, products, services, specifications or product descriptions at any time, without notice. Skyworks makes no commitment to update the materials or information and shall have no responsibility whatsoever for conflicts, incompatibilities, or other difficulties arising from any future changes.

No license, whether express, implied, by estoppel or otherwise, is granted to any intellectual property rights by this document. Skyworks assumes no liability for any materials, products or information provided hereunder, including the sale, distribution, reproduction or use of Skyworks products, information or materials, except as may be provided in Skyworks Terms and Conditions of Sale.

THE MATERIALS, PRODUCTS AND INFORMATION ARE PROVIDED "AS IS" WITHOUT WARRANTY OF ANY KIND, WHETHER EXPRESS, IMPLIED, STATUTORY, OR OTHERWISE, INCLUDING FITNESS FOR A PARTICULAR PURPOSE OR USE, MERCHANTABILITY, PERFORMANCE, QUALITY OR NON-INFRINGEMENT OF ANY INTELLECTUAL PROPERTY RIGHT; ALL SUCH WARRANTIES ARE HEREBY EXPRESSLY DISCLAIMED. SKYWORKS DOES NOT WARRANT THE ACCURACY OR COMPLETENESS OF THE INFORMATION, TEXT, GRAPHICS OR OTHER ITEMS CONTAINED WITHIN THESE MATERIALS. SKYWORKS SHALL NOT BE LIABLE FOR ANY DAMAGES, INCLUDING BUT NOT LIMITED TO ANY SPECIAL, INDIRECT, INCIDENTAL, STATUTORY, OR CONSEQUENTIAL DAMAGES, INCLUDING WITHOUT LIMITATION, LOST REVENUES OR LOST PROFITS THAT MAY RESULT FROM THE USE OF THE MATERIALS OR INFORMATION, WHETHER OR NOT THE RECIPIENT OF MATERIALS HAS BEEN ADVISED OF THE POSSIBILITY OF SUCH DAMAGE.

Skyworks products are not intended for use in medical, lifesaving or life-sustaining applications, or other equipment in which the failure of the Skyworks products could lead to personal injury, death, physical or environmental damage. Skyworks customers using or selling Skyworks products for use in such applications do so at their own risk and agree to fully indemnify Skyworks for any damages resulting from such improper use or sale.

Customers are responsible for their products and applications using Skyworks products, which may deviate from published specifications as a result of design defects, errors, or operation of products outside of published parameters or design specifications. Customers should include design and operating safeguards to minimize these and other risks. Skyworks assumes no liability for applications assistance, customer product design, or damage to any equipment resulting from the use of Skyworks products outside of stated published specifications or parameters.

Skyworks, the Skyworks symbol, and "Breakthrough Simplicity" are trademarks or registered trademarks of Skyworks Solutions, Inc., in the United States and other countries. Third-party brands and names are for identification purposes only, and are the property of their respective owners. Additional information, including relevant terms and conditions, posted at www.skyworksinc.com, are incorporated by reference.