



HMC232LP4 / 232LP4E

GaAs MMIC SPDT NON-REFLECTIVE SWITCH, DC - 12 GHz

Typical Applications

The HMC232LP4(E) is ideal for:

- Telecom Infrastructure
- Microwave Radio & VSAT
- Military Radios, Radar & ECM
- Test Instrumentation

Features

- Isolation: 60 dB @ 3 GHz
52 dB @ 6 GHz
- Input P1dB: +27 dBm
- Insertion Loss: 1.5 dB Typical @ 6 GHz
- Non-Reflective Design
- 24 Lead 4x4mm QFN Package: 16mm²
- Included in the HMC-DK005 Designer's Kit

Functional Diagram

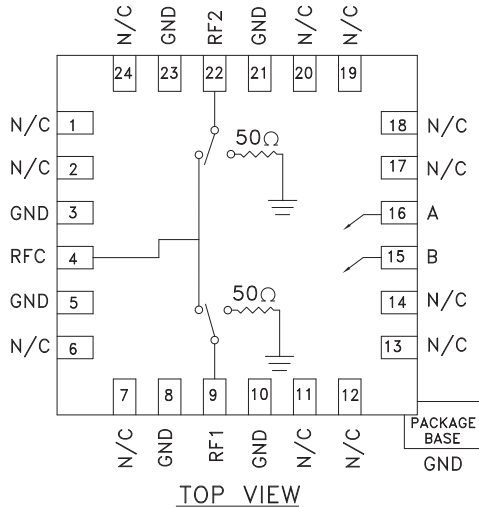

General Description

The HMC232LP4(E) is a broadband high isolation non-reflective GaAs MESFET SPDT switch in a low cost leadless QFN surface mount plastic package. Covering DC to 12 GHz, the switch features >60 dB isolation up to 3 GHz and >42 dB isolation up to 12 GHz. Input P1dB compression is +27 dBm typical, while input IP3 is +50 dBm. The switch operates using complementary negative control voltage logic lines of -5/0V and requires no bias supply.

Electrical Specifications, $T_A = +25^\circ C$, With 0/-5V Control, 50 Ohm System

Parameter	Frequency	Min.	Typ.	Max.	Units
Insertion Loss	DC - 3.0 GHz		1.4	1.7	dB
	DC - 6.0 GHz		1.5	1.8	dB
	DC - 9.0 GHz		2.0	2.3	dB
	DC - 12.0 GHz		2.7	3.1	dB
	Isolation	DC - 3.0 GHz	55	60	
	DC - 6.0 GHz	47	52		dB
	DC - 9.0 GHz	40	45		dB
	DC - 12.0 GHz	37	42		dB
Return Loss	"On State"	DC - 6.0 GHz		18	dB
		DC - 9.0 GHz		16	dB
		DC - 12.0 GHz		11	dB
Return Loss RF1, RF2	"Off State"	DC - 12.0 GHz		14	dB
Input Power for 1 dB Compression	0.5 - 12.0 GHz	24	27		dBm
Input Third Order Intercept (Two-Tone Input Power= +7 dBm Each Tone, 1 MHz Tone Separation)	0.5 - 12.0 GHz	45	50		dBm
Switching Characteristics	DC - 12.0 GHz	tRISE, tFALL (10/90% RF)		3	ns
		tON, tOFF (50% CTL to 10/90% RF)		6	ns

For price, delivery, and to place orders, please contact Hittite Microwave Corporation:
 20 Alpha Road, Chelmsford, MA 01824 Phone: 978-250-3343 Fax: 978-250-3373
 Order On-line at www.hittite.com

Insertion Loss

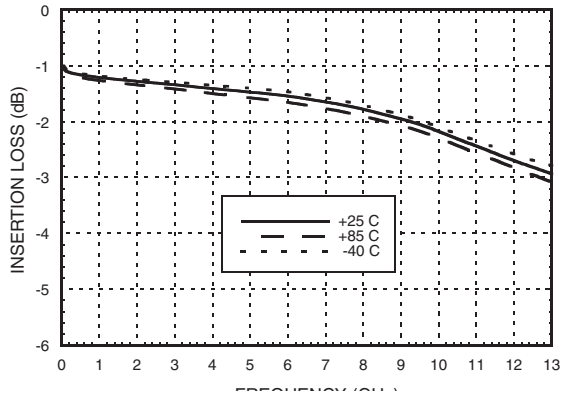

Isolation

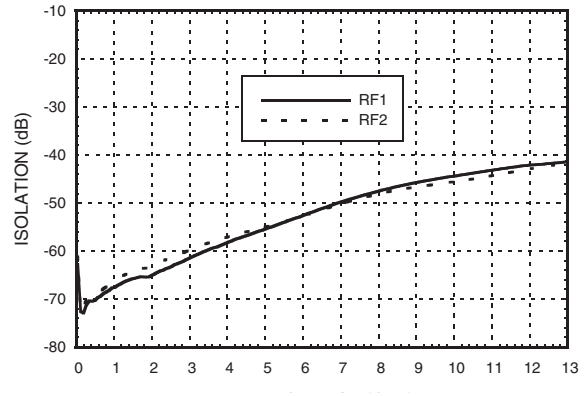

Return Loss

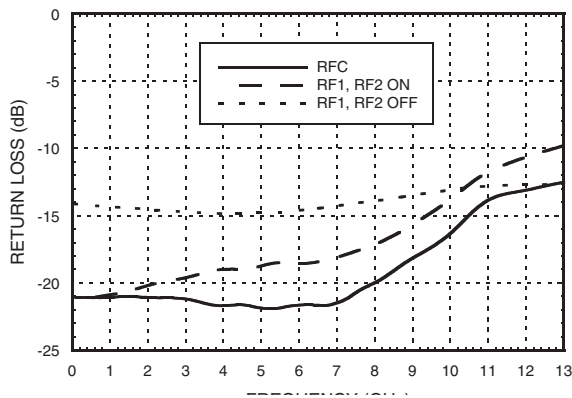

0.1 and 1 dB Input Compression Point

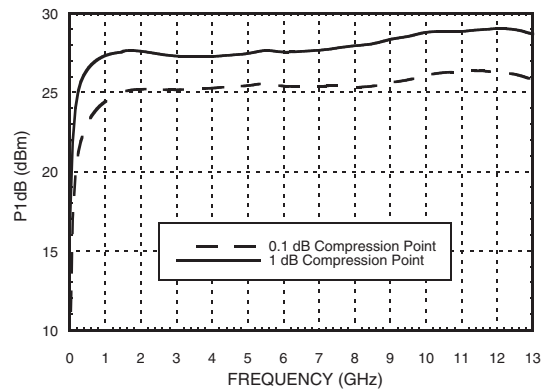

Input Third Order Intercept Point

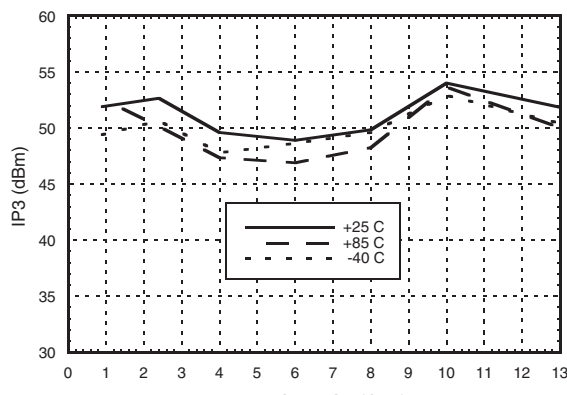

Absolute Maximum Ratings

RF Input Power (Vctl = -5V) (0.5 - 12 GHz)	+30 dBm (@ +50 °C)
RF1, RF2 Termination	+23.5 dBm
Control Voltage Range (A & B)	+1V to -7.5V
Channel Temperature	150 °C
Thermal Resistance (R _{TH}) (junction to lead)	94 °C/W
Storage Temperature	-65 to +150 °C
Operating Temperature	-40 to +85 °C
ESD Sensitivity (HBM)	Class 1A

Control Voltages

State	Bias Condition
Low	0 to -0.2V @ 10 uA Max.
High	-5V @ 10 uA Typ. to -7V @ 45 uA Typ. (±0.5 Vdc)

Truth Table

Control Input		Signal Path State	
A	B	RFC to RF1	RFC to RF2
High	Low	ON	OFF
Low	High	OFF	ON

Caution: Do not "Hot Switch" power levels greater than +27 dBm (Vctl = 0/-5 Vdc).



ELECTROSTATIC SENSITIVE DEVICE
OBSERVE HANDLING PRECAUTIONS

Outline Drawing

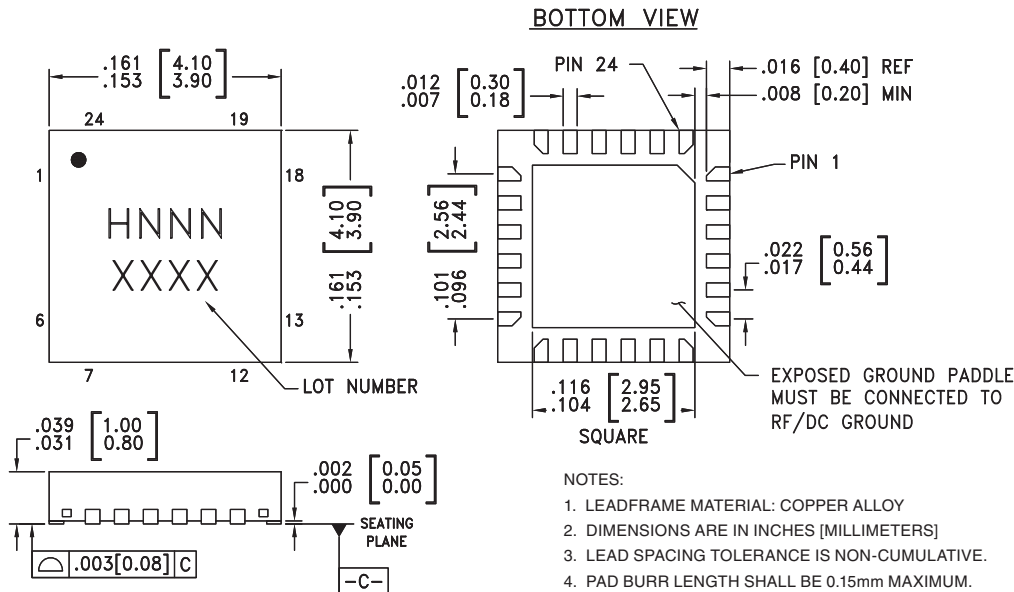

Package Information

Part Number	Package Body Material	Lead Finish	MSL Rating	Package Marking ^[3]
HMC232LP4	Low Stress Injection Molding Plastic	Sn/Pb Solder	MSL1 ^[1]	H232 XXXX
HMC232LP4E	RoHS-compliant Low Stress Injection Molding Plastic	100% matte Sn	MSL1 ^[2]	H232 XXXX

[1] Max peak reflow temperature of 235 °C

[2] Max peak reflow temperature of 260 °C

[3] 4-Digit lot number XXXX

Suggested Driver Circuit

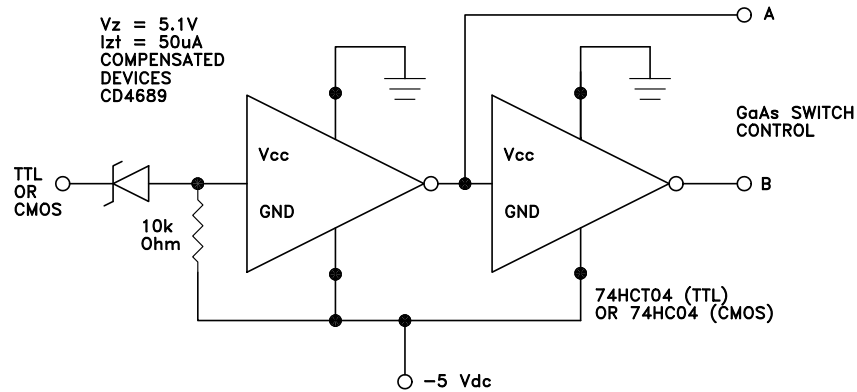

Pin Descriptions

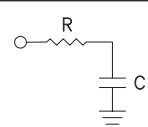
Pin Number	Function	Description	Interface Schematic
1, 2, 6, 7, 11, 12, 13, 14, 17, 18, 19, 20, 24	N/C	The pins are not connected internally; however, all data shown herein was measured with these pins connected to RF/DC ground externally.	
3, 5, 8, 10, 21, 23	GND	Package bottom must also be connected to PCB RF ground.	
4, 9, 22	RFC, RF1, RF2	This pin is DC coupled and matched to 50 Ohm. Blocking capacitors are required if RF line potential is not equal to 0V.	
15	B	See truth table and control voltage table.	
16	A	See truth table and control voltage table.	

Evaluation PCB

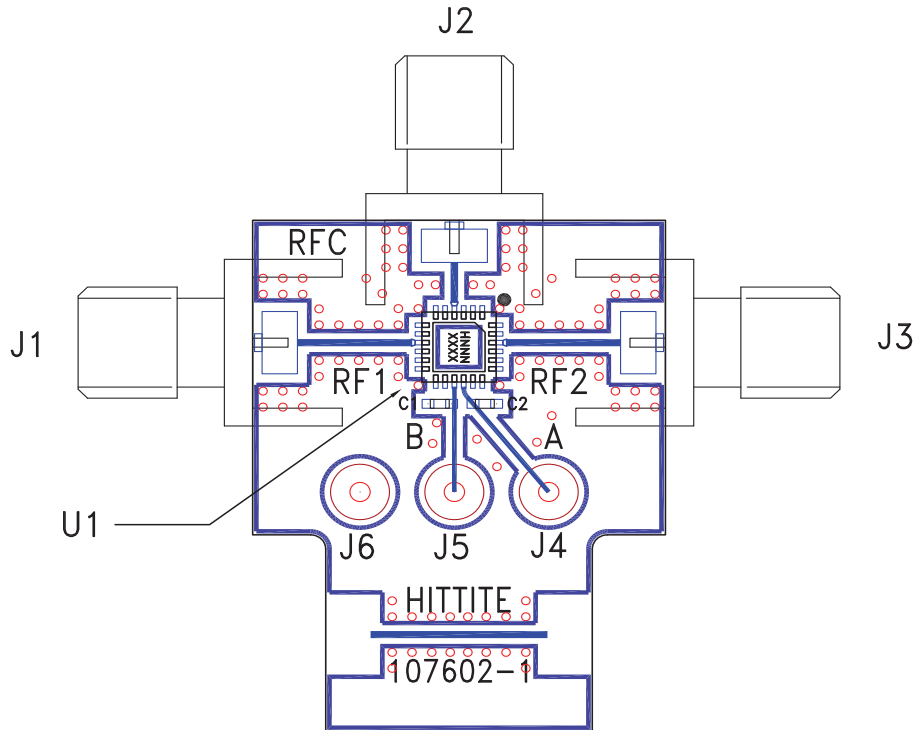

List of Materials for Evaluation PCB 107723 [1]

Item	Description
J1 - J3	PCB Mount SMA RF Connector
J4 - J6	DC Pin
C1, C2	100 pF Capacitor, 0603 Pkg.
U1	HMC232LP4 / HMC232LP4E SPDT Switch
PCB [2]	107602 Evaluation PCB

[1] Reference this number when ordering complete evaluation PCB

[2] Circuit Board Material: Rogers 4350

The circuit board used in the application should be generated with proper RF circuit design techniques. Signal lines at the RF port should have 50 Ohm impedance and the package ground leads and package bottom should be connected directly to the ground plane similar to that shown above. The evaluation circuit board shown above is available from Hittite Microwave Corporation upon request.



Notes: