



## SPDT NON-REFLECTIVE SWITCH DC - 3.5 GHz

### Typical Applications

The HMC284AMS8G / HMC284AMS8GE is ideal for:

- Cellular/PCS Base Stations
- 2.4 GHz ISM
- 3.5 GHz Wireless Local Loop

### Features

- High Isolation: >45 dB
- Positive control: 0/+5V
- Non-Reflective Design
- Ultra Small Package: MSOP8G
- Included in the HMC-DK005 Designers' Kit

### Functional Diagram

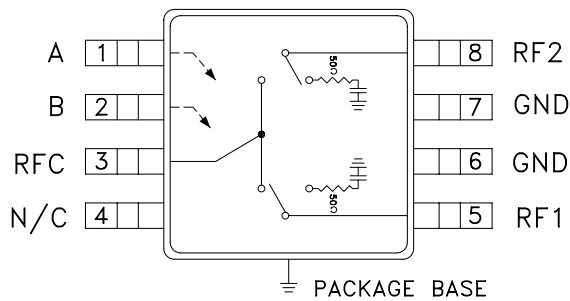

### General Description

The HMC284AMS8G & HMC284AMS8GE are low-cost SPDT switches in 8-lead grounded base MSOP packages. The design has been optimized to provide high isolation with minimal insertion loss for medium and low power applications. On-chip circuitry allows positive voltage control operation at very low DC currents with control inputs compatible with CMOS and most TTL logic families. In the "OFF" state, RF1 and RF2 are non-reflective.

### Electrical Specifications, $T_A = +25^\circ\text{C}$ , $V_{ctl} = 0/+5\text{Vdc}$ , 50 Ohm System

| Parameter   | Frequency                 | Min.                             | Typ.  | Max.    | Units    |
|---|---------------------------|----------------------------------|-------|---------|----------|
| Insertion Loss  | DC - 2.0 GHz              |                                  | 0.5   | 0.8     | dB       |
|   | DC - 3.0 GHz              |                                  | 0.6   | 0.9     | dB       |
|   | DC - 3.5 GHz              |                                  | 0.7   | 1.1     | dB       |
| Isolation   | RF1 & RF2<br>DC - 2.0 GHz | 41                               | 45    |         | dB       |
|   | RF1 / RF2<br>DC - 2.5 GHz | 38/41                            | 44/45 |         | dB       |
|   | RF1 / RF2<br>DC - 3.0 GHz | 34/36                            | 42/45 |         | dB       |
|   | RF1 & RF2<br>DC - 3.5 GHz | 30                               | 40    |         | dB       |
| Return Loss (On State)  | DC - 2.0 GHz              | 21                               | 25    |         | dB       |
|   | DC - 2.5 GHz              | 13                               | 22    |         | dB       |
|   | DC - 3.5 GHz              | 10                               | 17    |         | dB       |
| Return Loss (Off State)   | 0.5 - 3.5 GHz             | 10                               | 15    |         | dBm      |
| Input Power for 1 dB Compression  | 0.5 - 1.0 GHz             | 20                               | 30    |         | dBm      |
|   | 0.5 - 3.5 GHz             | 18                               | 29    |         | dBm      |
| Input Third Order Intercept<br>(Two-Tone Input Power = 0 dBm Each Tone) | 0.5 - 3.5 GHz             | 43                               | 50    |         | dBm      |
| Switching Speed   | DC - 3.5 GHz              | tRISE, tFALL (10/90% RF)         |       |         |          |
|   |                           | tON, tOFF (50% CTL to 10/90% RF) |       | 5<br>20 | ns<br>ns |



**SPDT NON-REFLECTIVE SWITCH  
DC - 3.5 GHz**

**Insertion Loss**

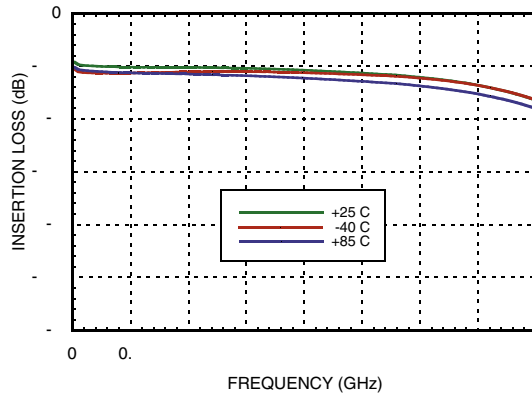

**Isolation**

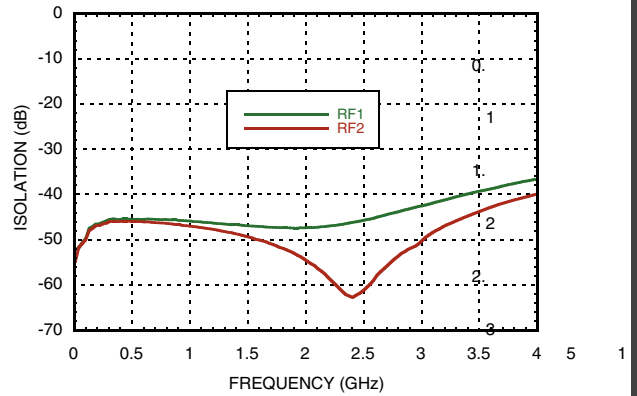

**Return Loss**

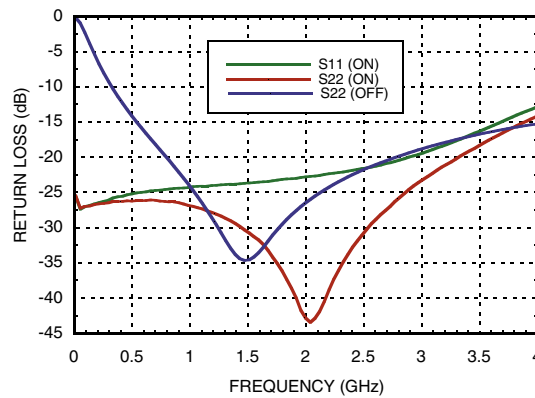



## SPDT NON-REFLECTIVE SWITCH DC - 3.5 GHz

### Compression vs Frequency

| CTL Input | Carrier at 900 MHz                 |                                    | Carrier at 1900 MHz                |                                    |
|-----------|------------------------------------|------------------------------------|------------------------------------|------------------------------------|
|           | Input Power for 0.1 dB Compression | Input Power for 1.0 dB Compression | Input Power for 0.1 dB Compression | Input Power for 1.0 dB Compression |
| (Vdc)     | (dBm)                              | (dBm)                              | (dBm)                              | (dBm)                              |
| +5        | 27                                 | 30                                 | 27                                 | 29                                 |

Caution:  
Do not operate continuously at RF power input greater than 1 dB compression. (Vctl = 0/+5 Vdc).

### Distortion vs Frequency

| Control Input | Third Order Intercept (dBm)<br>0 dBm Each Tone |          |
|---------------|--|----------|
|               | 900 MHz  | 1900 MHz |
| (Vdc)         |  |          |
| +5            | 50   | 50       |

### Truth Table

\*Control Input Tolerances are  $\pm 0.2$  Vdc

| Control Input* |         | Control Current |         | Signal Path State |            |
|----------------|---------|-----------------|---------|-------------------|------------|
| A (Vdc)        | B (Vdc) | Ia (uA)         | Ib (uA) | RFC to RF1        | RFC to RF2 |
| 0              | +5      | -0.2            | 0.2     | ON                | OFF        |
| +5             | 0       | 0.2             | -0.2    | OFF               | ON         |

DC blocks are required at ports RFC, RF1, RF2.

**SPDT NON-REFLECTIVE SWITCH  
 DC - 3.5 GHz**
**Absolute Maximum Ratings**

|  |                  |
|--|------------------|
| RF Input Power (Vctl = 0/+5V)            | +26 dBm          |
| Control Voltage Range                    | -0.5 to +7.5 Vdc |
| Hot Switch Power Level (Vctl = 0/+5V)    | +18 dBm          |
| Channel Temperature                      | 150 °C           |
| Thermal Resistance (Insertion Loss Path) | 130 °C/W         |
| Thermal Resistance (Terminated Path)     | 252 °C/W         |
| Storage Temperature                      | -65 to +150 °C   |
| Operating Temperature                    | -40 to +85 °C    |
| ESD Sensitivity (HBM)                    | Class 1A         |

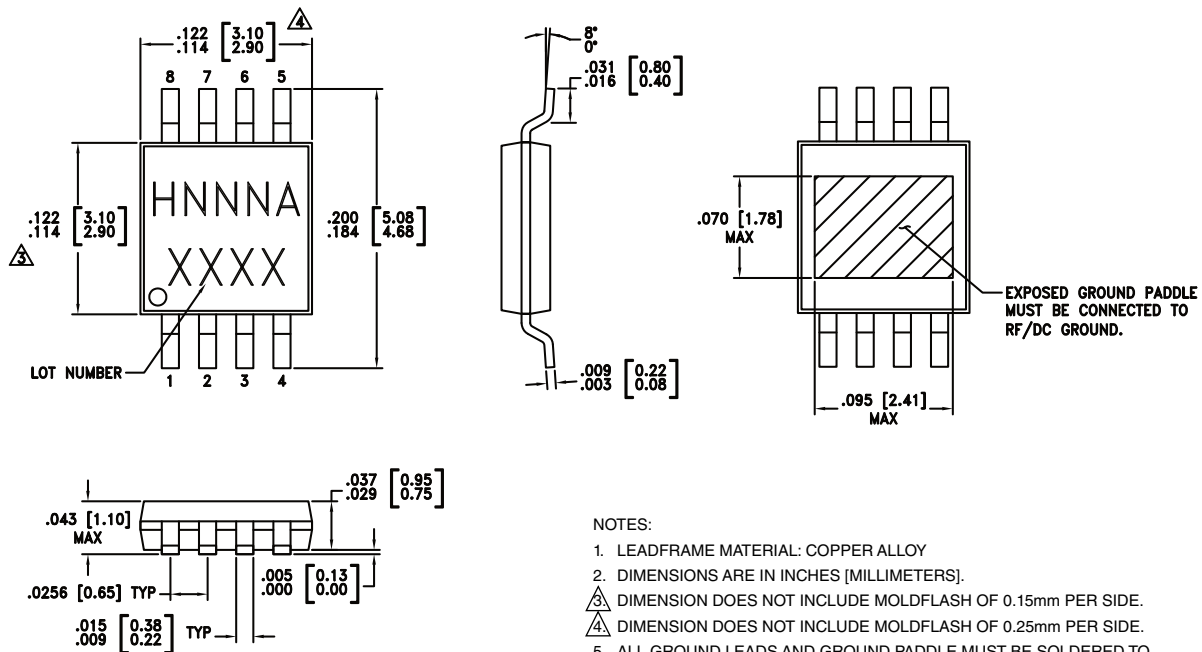
**ELECTROSTATIC SENSITIVE DEVICE  
 OBSERVE HANDLING PRECAUTIONS**
**Outline Drawing**

**Package Information**

| Part Number  | Package Body Material                              | Lead Finish   | MSL Rating          | Package Marking <sup>[3]</sup> |
|--------------|--|---------------|---------------------|--------------------------------|
| HMC284AMS8G  | Low Stress Injection Molded Plastic                | Sn/Pb Solder  | MSL1 <sup>[1]</sup> | H284A<br>XXXX                  |
| HMC284AMS8GE | RoHS-compliant Low Stress Injection Molded Plastic | 100% matte Sn | MSL1 <sup>[2]</sup> | H284A<br>XXXX                  |

[1] Max peak reflow temperature of 235 °C

[2] Max peak reflow temperature of 260 °C

[3] 4-Digit lot number XXXX

**Typical Application Circuit**

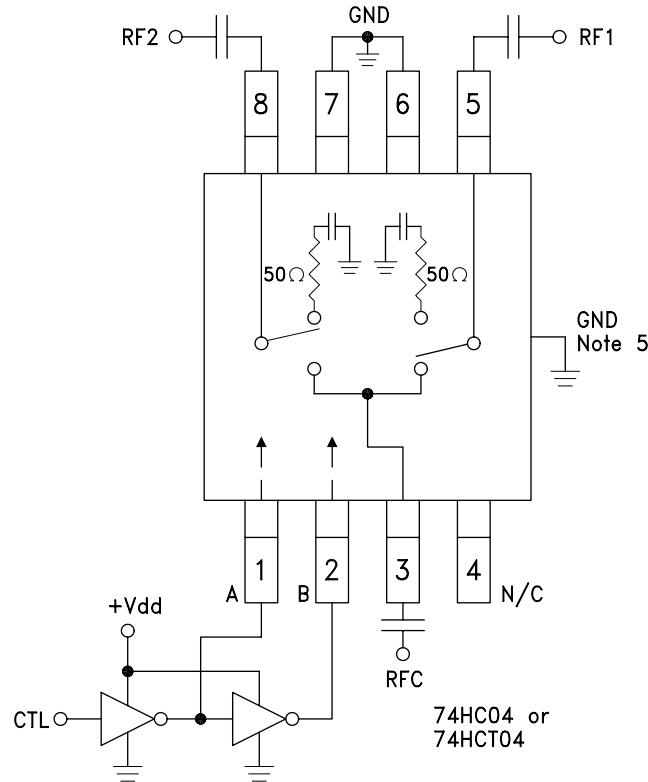

**Notes:**

1. Set A/B control to 0/+5V, Vdd = +5V and use HCT series logic to provide a TTL driver interface.
2. Control inputs A/B can be driven directly with CMOS logic (HC) with Vdd = +5 Volts applied to the CMOS logic gates.
3. DC blocking capacitors are required for each RF port as shown. Capacitor value determines lowest frequency of operation.
4. Highest RF signal power capability is achieved with Vdd = +7V and A/B set to 0/+7V.
5. Back side paddle must be connected to RF ground.
6. A grounded coplanar waveguide PCB layout technique is recommended to achieve high isolation. The component side ground plane between RFC/grounded paddle and RF1/RF2 should be continuous, see below. There should be a continuous ground plane under component side layout.

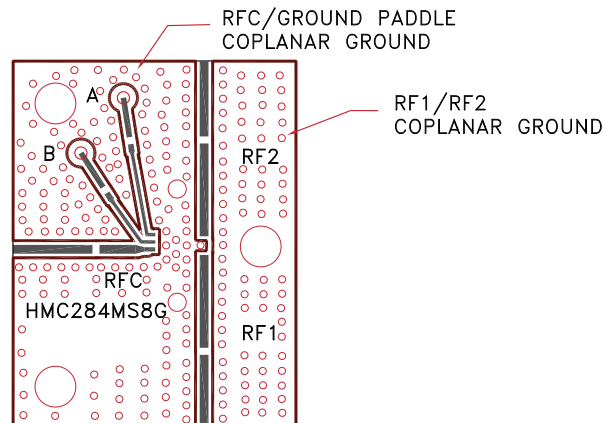



## SPDT NON-REFLECTIVE SWITCH DC - 3.5 GHz

### Evaluation PCB

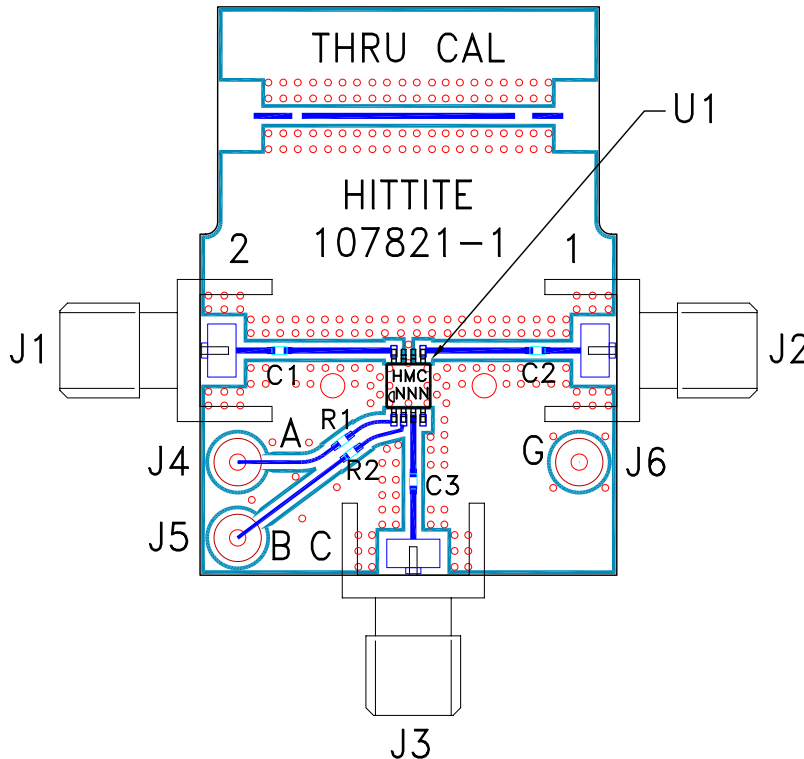

### List of Materials for Evaluation PCB 105143 [1]

| Item    | Description                            |
|---------|--|
| J1 - J3 | PCB Mount SMA RF Connector             |
| J4 - J6 | DC Pin                                 |
| C1 - C3 | 100 pF capacitor, 0402 Pkg.            |
| R1, R2  | 100 Ohm resistor, 0402 Pkg.            |
| U1      | HMC284AMS8G / HMC284AMS8GE SPDT Switch |
| PCB [2] | 107821 Evaluation PCB                  |

[1] Reference this number when ordering complete evaluation PCB

[2] Circuit Board Material: Rogers 4350

The circuit board used in the application should be generated with proper RF circuit design techniques. Signal lines at the RF port should have 50 Ohm impedance and the package ground leads and package bottom should be connected directly to the ground plane similar to that shown above. The evaluation circuit board shown above is available from Hittite Microwave Corporation upon request.