

Typical Applications

This switch is suitable for usage in DC - 8.0 GHz 50-Ohm or 75-Ohm systems:

- Broadband
- Fiber Optics
- Switched Filter Banks
- Wireless below 8 GHz

Features

- Broadband Performance: DC - 8.0 GHz
- High Isolation: >30 dB@ 6 GHz
- Low Insertion Loss: 2.4 dB@ 6 GHz
- Integrated 3:8 TTL Decoder
- 24 Lead 4x4mm QFN Package: 9 mm²

Functional Diagram

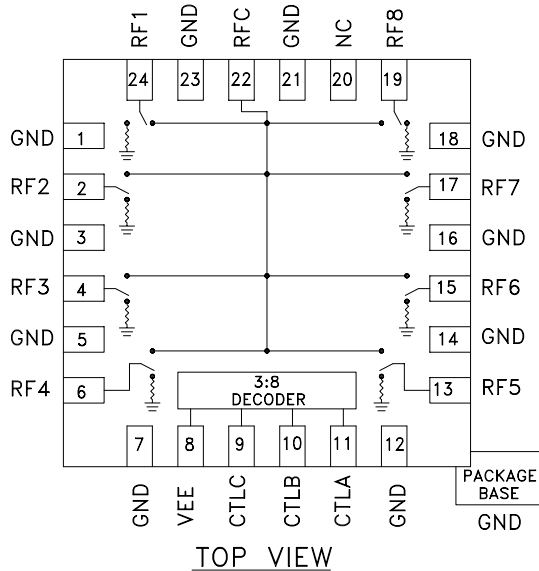

General Description

The HMC322LP4 & HMC322LP4E are broadband non-reflective GaAs MESFET SP8T switches in low cost leadless surface mount packages. Covering DC to 8 GHz, this switch offers high isolation and low insertion loss. This switch also includes an on board binary decoder circuit which reduces the required logic control lines to three. The switch operates using a negative control voltage of 0/-5 volts, and requires a fixed bias of -5V. This switch is suitable for usage in 50-Ohm or 75-Ohm systems.

Electrical Specifications, $T_A = +25^\circ \text{C}$, With 0/-5V Control, 50 Ohm System

Parameter	Frequency	Min.	Typ.	Max.	Units
Insertion Loss	DC - 2.0 GHz		2.1	2.5	dB
	DC - 4.0 GHz		2.3	2.7	dB
	DC - 8.0 GHz		2.5	2.9	dB
Isolation	DC - 2.0 GHz	35	40		dB
	DC - 4.0 GHz	30	35		dB
	DC - 6.0 GHz	25	30		dB
	DC - 8.0 GHz	20	25		dB
Return Loss	"On State"	DC - 2.0 GHz	9	12	dB
		DC - 8.0 GHz	6	10	dB
Return Loss	"Off State"	DC - 8.0 GHz	7	10	dB
Input Power for 1 dB Compression	0.5 - 8.0 GHz	19	23		dBm
Input Third Order Intercept (Two-Tone Input Power = +7 dBm Each Tone)	0.5 - 8.0 GHz	36	40		dBm
Switching Characteristics tRISE, tFALL (10/90% RF) tON, tOFF (50% CTL to 10/90% RF)	DC - 8.0 GHz		50		ns
			150		ns

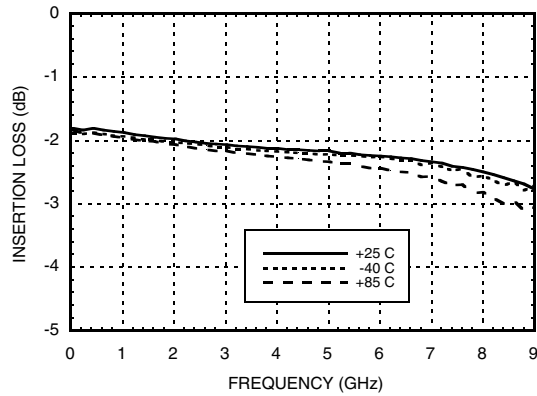
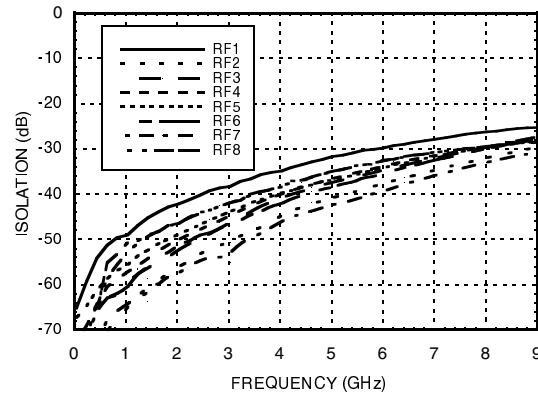
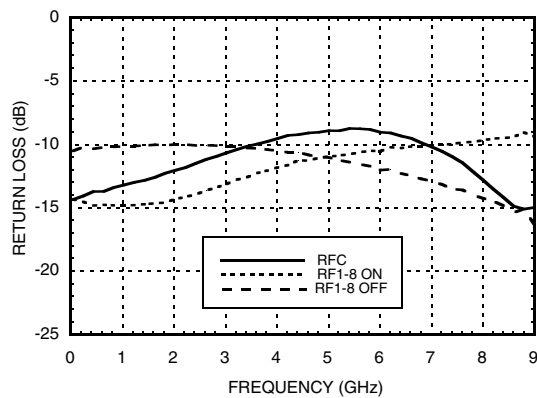
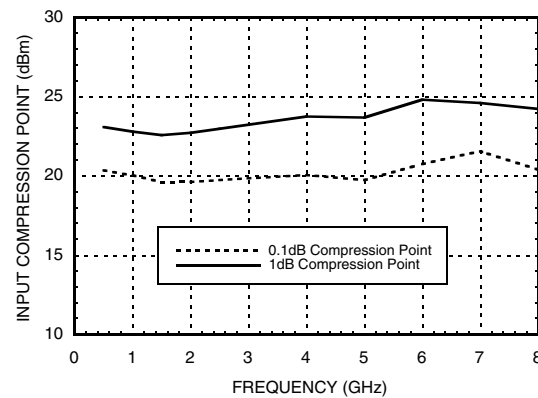
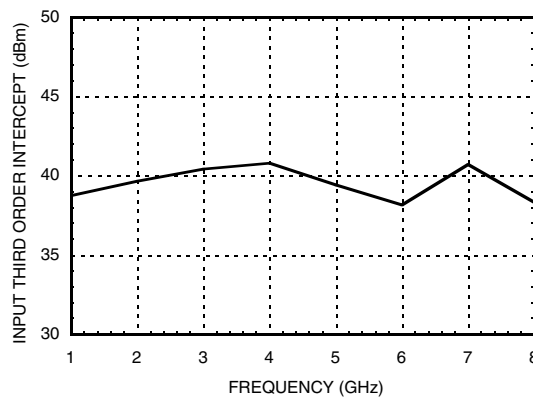
Insertion Loss vs. Temperature

Isolation

Return Loss

0.1 and 1 dB Input Compression Point

Input Third Order Intercept Point



Bias Voltage & Current

Vee Range = -5.0 Vdc \pm 10%		
Vee (Vdc)	Iee (Typ.) (mA)	Iee (Max.) (mA)
-5.0	5.0	9.0

Control Voltages

State	Bias Condition
Low	-3V to 0 Vdc @ 25 μ A Typical
High	-5 to -4.2 Vdc @ 5 μ A Typical

Truth Table

Control Input			Signal Path State
A	B	C	RFCOM to:
High	High	High	RF1
Low	High	High	RF2
High	Low	High	RF3
Low	Low	High	RF4
High	High	Low	RF5
Low	High	Low	RF6
High	Low	Low	RF7
Low	Low	Low	RF8

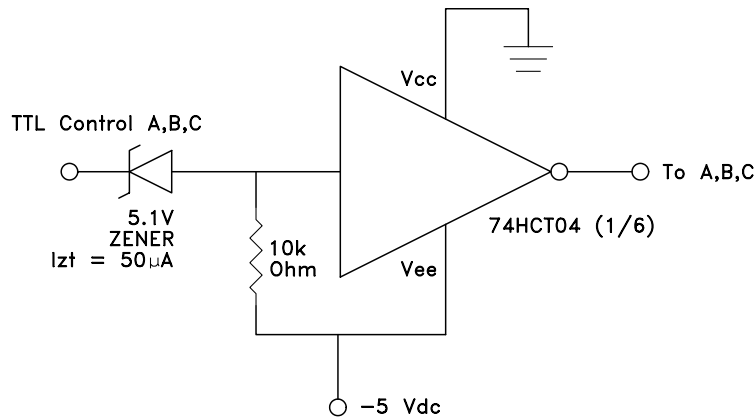
TTL Interface Circuit

Note:

Control inputs A, B, and C can be driven directly with TTL logic with -5 Volts applied to the HCT logic gates Vee pin and to Vee (pin 8) of the RF Switch.

Absolute Maximum Ratings

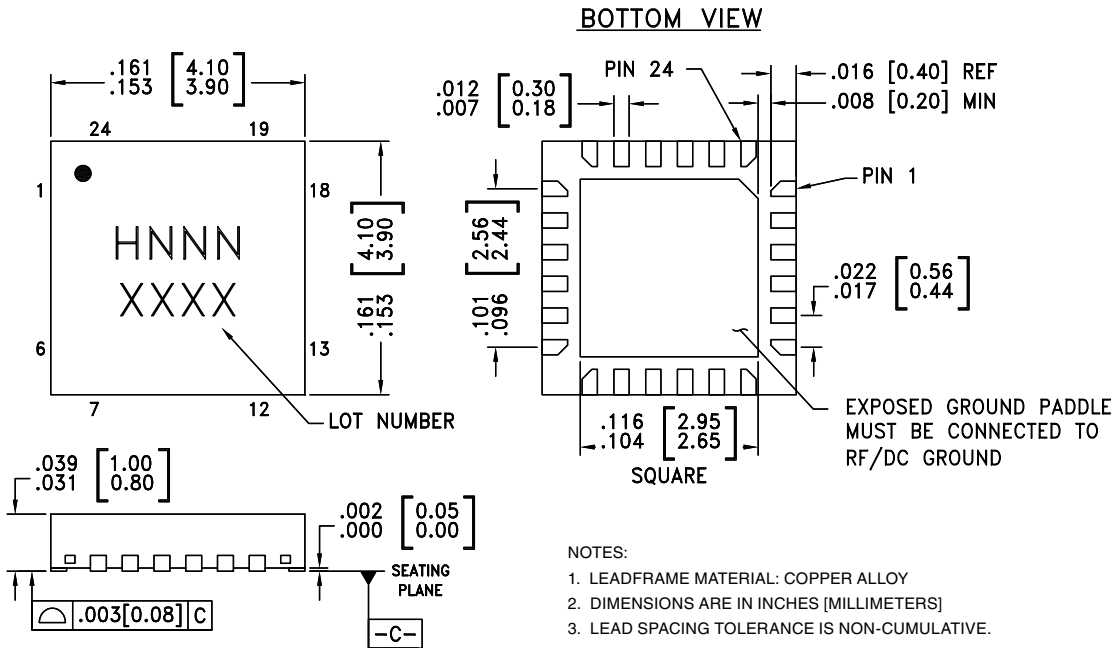
Bias Voltage Range (Vee)	-7.0 Vdc
Control Voltage Range (A, B, & C)	Vee -0.5V to +1.0 Vdc
Storage Temperature	-65 to +150 °C
Operating Temperature	-40 to +85 °C
Maximum Input Power	26 dBm
Channel Temperature	150 °C
Continuous P _{diss} (T = 85 °C) (derate 5.34 mW / °C)	0.348 W
Thermal Resistance	187 °C / W
ESD Sensitivity (HBM)	Class 1B

**ELECTROSTATIC SENSITIVE DEVICE
OBSERVE HANDLING PRECAUTIONS**
Outline Drawing

NOTES:

- LEADFRAME MATERIAL: COPPER ALLOY
- DIMENSIONS ARE IN INCHES [MILLIMETERS]
- LEAD SPACING TOLERANCE IS NON-CUMULATIVE.
- PAD BURR LENGTH SHALL BE 0.15mm MAXIMUM.
PAD BURR HEIGHT SHALL BE 0.05mm MAXIMUM.
- PACKAGE WARP SHALL NOT EXCEED 0.05mm.
- ALL GROUND LEADS AND GROUND PADDLE MUST BE SOLDERED TO PCB RF GROUND.
- REFER TO HITTITE APPLICATION NOTE FOR SUGGESTED LAND PATTERN.

Package Information

Part Number	Package Body Material	Lead Finish	MSL Rating	Package Marking ^[3]
HMC322LP4	Low Stress Injection Molded Plastic	Sn/Pb Solder	MSL1 ^[1]	H322 XXXX
HMC322LP4E	RoHS-compliant Low Stress Injection Molded Plastic	100% matte Sn	MSL1 ^[2]	H322 XXXX

[1] Max peak reflow temperature of 235 °C

[2] Max peak reflow temperature of 260 °C

[3] 4-Digit lot number XXXX

Pin Descriptions

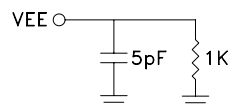
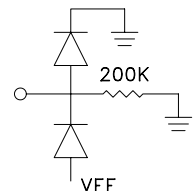
Pin Number	Function	Description	Interface Schematic
1, 3, 5, 7, 12, 14, 16, 18, 21, 23	GND	Package bottom has exposed metal paddle that must also be connected to PCB RF ground.	
2, 4, 6, 13, 15, 17, 19, 22, 24	RF1 - RF8 & RFC	This pin is DC coupled and matched to 50 Ohm. Blocking capacitors are required if RF line potential is not equal to 0V.	
8	VEE	Supply Voltage = $-5V \pm 10\%$	
9	CTLC	See truth table and control voltage table.	
10	CTLB	See truth table and control voltage table.	
11	CTLA	See truth table and control voltage table.	
20	N/C	This pin should be connected to PCB RF ground to maximize isolation.	

Evaluation PCB

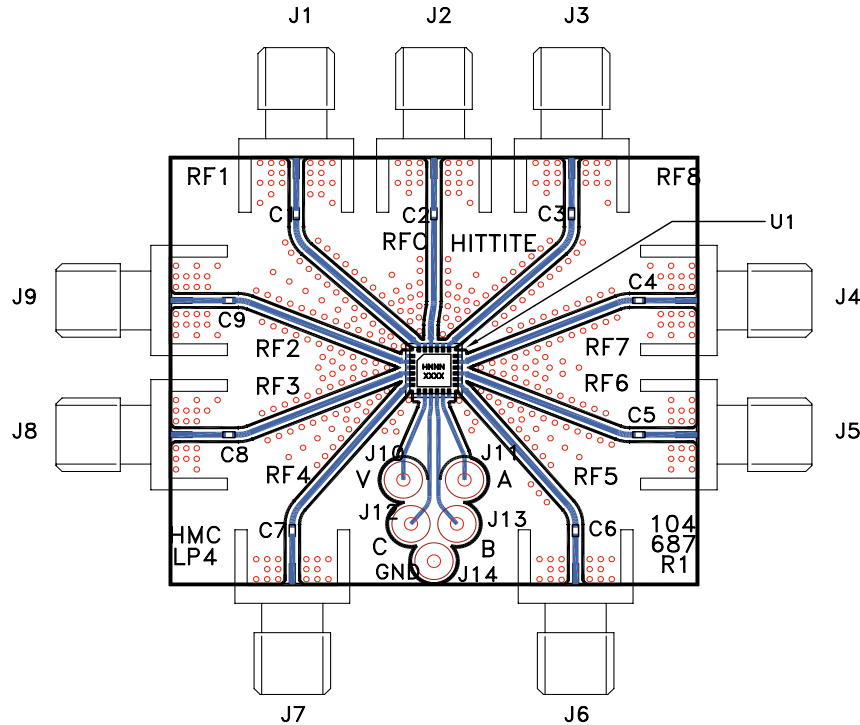

List of Materials for Evaluation PCB 107780 [1]

Item	Description
J1 - J9	PCB Mount SMA RF Connector
J10 - J14	DC Pin
C1 - C9	100 pF Capacitor, 0402 Pkg.
U1	HMC322LP4 / HMC322LP4E SP8T Switch
PCB [2]	104687 Evaluation PCB 1.73"x1.46"

[1] Reference this number when ordering complete evaluation PCB

[2] Circuit Board Material: Rogers 4350

The circuit board used in the application should be generated with proper RF circuit design techniques. Signal lines at the RF port should have 50 ohm impedance and the package ground leads and backside ground slug should be connected directly to the ground plane similar to that shown above. The evaluation circuit board shown above is available from Hittite Microwave Corporation upon request.