

Typical Applications

Prescaler for 10 to 26 GHz PLL Applications:

- Point-to-Point / Multi-Point Radios
- VSAT Radios
- Fiber Optic
- Test Equipment
- Military

Functional Diagram

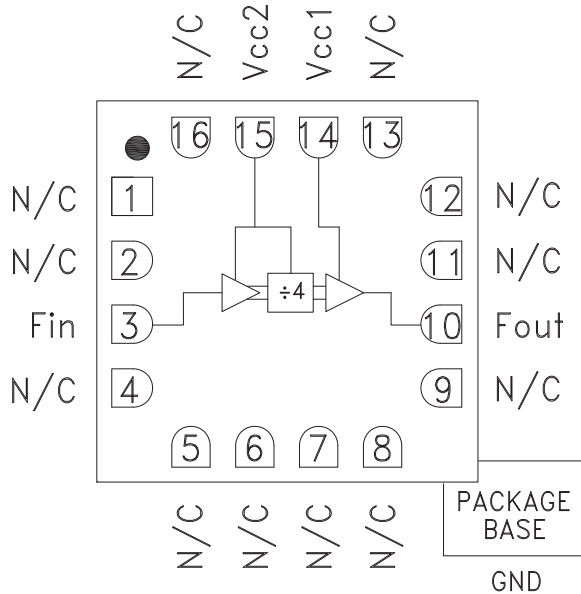

Features

- Very Wide Bandwidth
- Ultra Low SSB Phase Noise: -150 dBc/Hz
- Output Power: -4 dBm
- Single DC Supply: +5V
- RoHS Compliant 3x3 mm SMT Package

General Description

The HMC447LC3 is a low noise Divide-by-4 Regenerative Divider utilizing InGaP GaAs HBT technology. This wideband divider operates with input frequencies from 10 to 26 GHz, and accepts a very wide range of input power levels. The HMC447LC3 exhibits a very low SSB Phase Noise of -150 dBc/Hz at 100 kHz offset, making it ideal for use in high frequency Phase Locked Loops (PLL), and in Local Oscillator (LO) distribution applications where fundamental and divided LO frequencies are required within a system. This versatile divider consumes only 96 mA from a single positive supply of +5V, and delivers very flat output power across the rated bandwidth. The HMC447LC3 is housed in a RoHS compliant, 3x3 mm leadless SMT package with an exposed ground paddle.

Electrical Specifications, $T_A = +25^\circ \text{C}$, 50 Ohm System, $V_{cc} = +5V$

Parameter	Conditions	Min.	Typ.	Max.	Units
Maximum Input Frequency		26	27		GHz
Minimum Input Frequency			9	10	GHz
Input Power Range	$F_{in} = 10$ to 14 GHz	-15	-20	+10	dBm
	$F_{in} = 14$ to 18 GHz	-15	-20	+5	dBm
	$F_{in} = 18$ to 20 GHz	-10	-15	+10	dBm
	$F_{in} = 20$ to 22 GHz	-5	-10	+10	dBm
	$F_{in} = 22$ to 26 GHz	0	-5	+10	dBm
Output Power	$F_{in} = 10$ to 26 GHz	-7	-4		dBm
Reverse Leakage	RF Output Terminated		50		dB
SSB Phase Noise (100 kHz offset)	$P_{in} = 0$ dBm, $F_{in} = 22$ GHz		-150		dBc/Hz
Output Transition Time	$P_{in} = 0$ dBm, $F_{out} = 4500$ MHz		100		ps
Supply Current ($I_{cc1} + I_{cc2}$)			96		mA



Input Sensitivity Window, $T = 25\text{ }^\circ\text{C}$

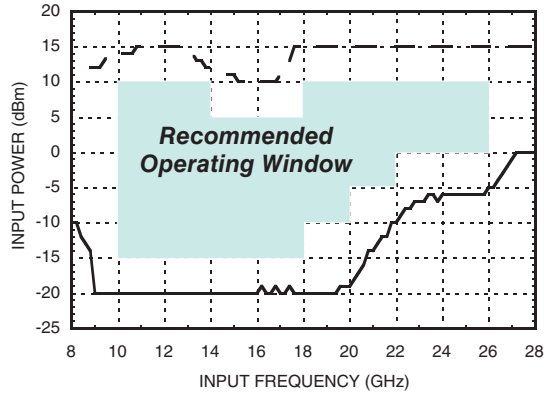

Input Sensitivity Window vs. Temperature

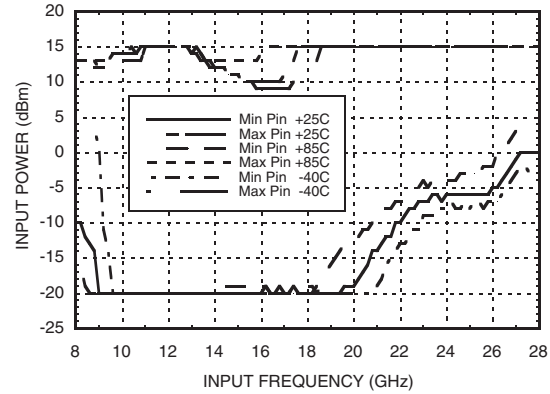

Output Power vs. Temperature

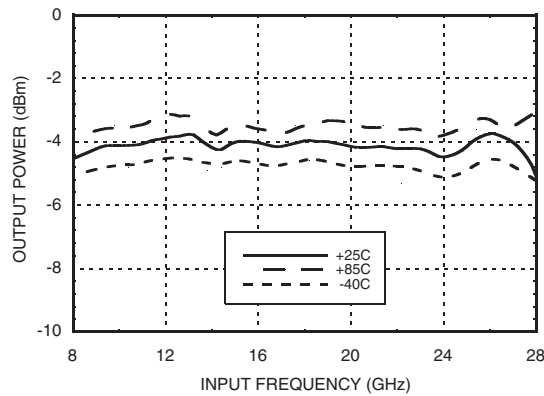

**SSB Phase Noise Performance,
 $P_{in} = 0\text{ dBm}$, $F_{in} = 22\text{ GHz}$, $T = 25\text{ }^\circ\text{C}$**

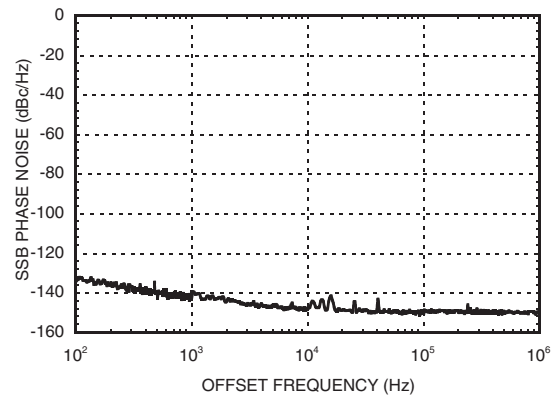

**Output Harmonic Content,
 $P_{in} = 0\text{ dBm}$, $T = 25\text{ }^\circ\text{C}$**

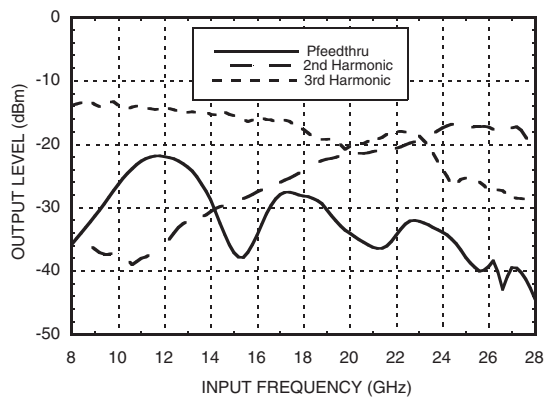

**Reverse Leakage, $P_{in} = 0\text{ dBm}$, $T = 25\text{ }^\circ\text{C}$
Output Port Terminated**

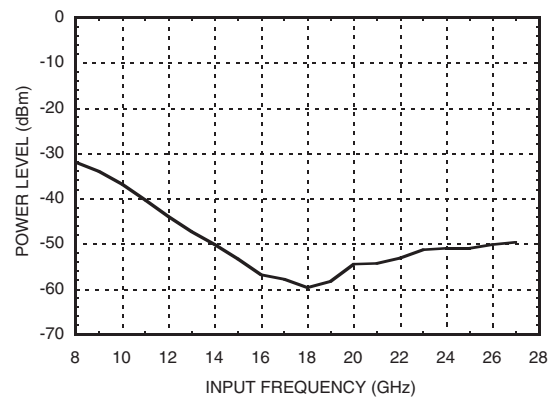



Output Voltage Waveform,
Pin= 0 dBm, Fout= 2.5 GHz, T= 25 °C

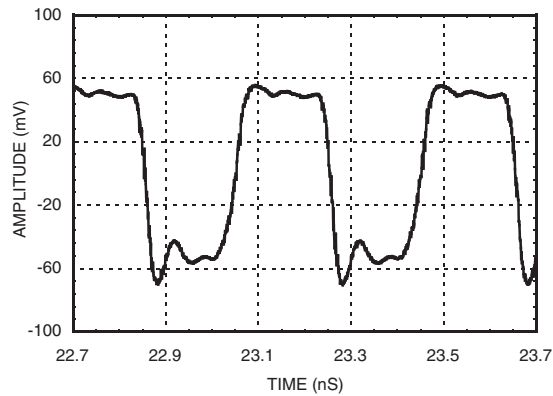

ELECTROSTATIC SENSITIVE DEVICE
OBSERVE HANDLING PRECAUTIONS

Absolute Maximum Ratings

RF Input (Vcc = +5V)	+13 dBm
Supply Voltage (Vcc1, Vcc2)	+5.5V
Junction Temperature (Tj)	135 °C
Continuous P _{diss} (T = 85 °C) (derate 11.9 mW/°C above 85 °C)	595 mW
Thermal Resistance (R _{TH}) (junction to ground paddle)	84 °C/W
Storage Temperature	-65 to +150 °C
Operating Temperature	-40 to +85 °C
ESD Sensitivity (HBM)	Class 1A

Typical Supply Current vs. Vcc

Vcc1, Vcc2 (V)	I _{cc} (mA)
4.75	84
5.0	96
5.25	108

Note: Divider will operate over full voltage range shown above

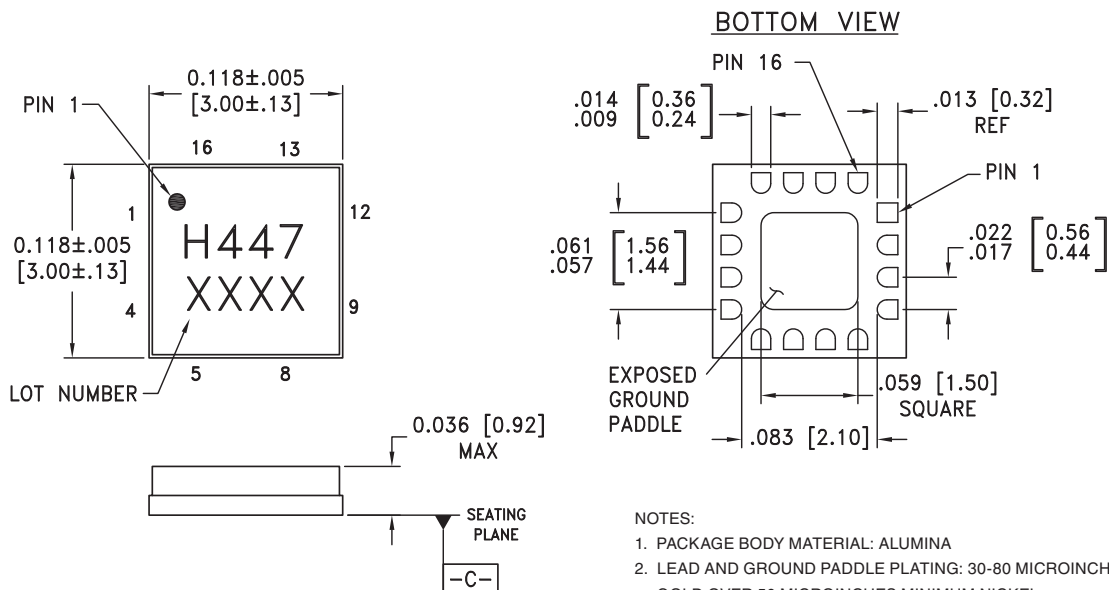

Outline Drawing



- NOTES:
1. PACKAGE BODY MATERIAL: ALUMINA
 2. LEAD AND GROUND PADDLE PLATING: 30-80 MICROINCHES GOLD OVER 50 MICROINCHES MINIMUM NICKEL.
 3. DIMENSIONS ARE IN INCHES [MILLIMETERS]
 4. LEAD SPACING TOLERANCE IS NON-CUMULATIVE.
 5. PACKAGE WARP SHALL NOT EXCEED 0.05mm DATUM [C].
 6. ALL GROUND LEADS AND GROUND PADDLE MUST BE SOLDERED TO PCB RF GROUND.
 7. CLASSIFIED AS MOISTURE SENSITIVITY LEVEL (MSL) 1.

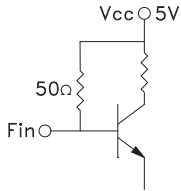
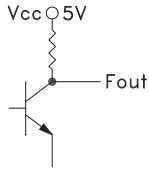

Pin Description

Pin Number	Function	Description	Interface Schematic
1,2, 4 - 9, 11 12, 13, 16	N/C	No connection. These pins may be connected to RF/DC ground. Performance will not be affected.	
3	Fin	RF Input must be DC blocked.	
10	Fout	Divided Output must be DC blocked.	
14, 15	Vcc1, Vcc2	Supply voltage 5V ± 0.25V. Connect both pins to +5V supply.	
	GND	Backside of package has exposed metal ground paddle which must be connected to RF/DC ground.	



Evaluation PCB

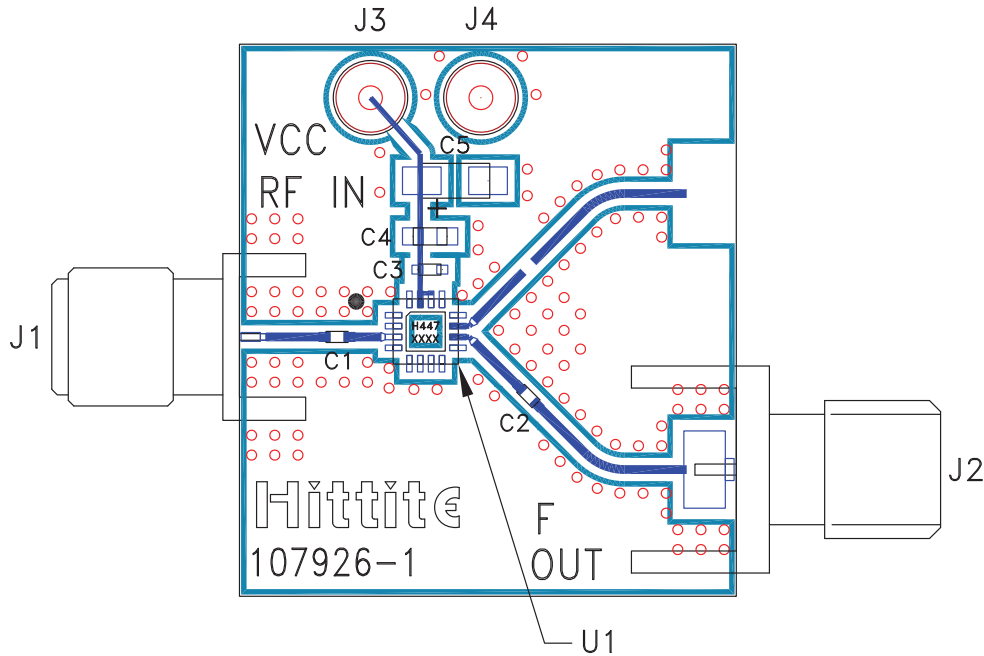

List of Materials for Evaluation PCB 107928 [1]

Item	Description
J1	PCB Mount SRI K-Connector
J2	PCB Mount SMA RF Connector
J3, J4	DC Pin
C1	10pF Capacitor, 0402 Pkg.
C2, C3	100 pF Capacitor, 0402 Pkg.
C4	10000 pF Capacitor, 0603 Pkg.
C5	2.2 uF Tantalum Capacitor
U1	HMC447LC3 Divide-by-4
PCB [2]	107926 Eval Board

[1] Reference this number when ordering complete evaluation PCB

[2] Circuit Board Material: Rogers 4350

The circuit board used in the final application should use RF circuit design techniques. Signal lines should have 50 ohm impedance while the package ground leads and backside ground paddle should be connected directly to the ground plane similar to that shown. A sufficient number of via holes should be used to connect the top and bottom ground planes. The evaluation circuit board shown is available from Hittite upon request.



Application Circuit

