

GaAs MMIC SP4T NON-REFLECTIVE SWITCH, DC - 20 GHz

Typical Applications

The HMC641LC4 is ideal for:

- Telecom Infrastructure
- Microwave Radio & VSAT
- Military & Space Hybrids
- Test Instrumentation
- SATCOM & Sensors

Features

- Broadband Performance: DC - 20 GHz
- High Isolation: 42 dB @ 12 GHz
- Low Insertion Loss: 2.1 dB @ 12 GHz
- Integrated 2:4 TTL Decoder
- 24 Lead 4x4mm SMT Package: 16mm²

Functional Diagram

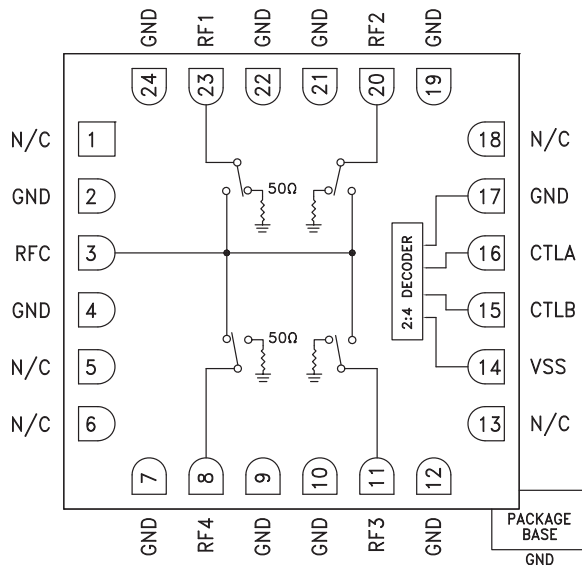

General Description

The HMC641LC4 is a broadband non-reflective GaAs pHEMT SP4T switch in a compact 4x4 mm ceramic package. Covering DC to 20 GHz, this switch offers high isolation, low insertion loss and on-chip termination of isolated ports. This switch also includes an on board binary decoder circuit which reduces the number of required logic control lines from four to two. The HMC641LC4 is controlled with 0/ -5V logic, exhibits fast switching speed and consumes much less DC current than pin diode based solutions. The HMC641LC4 is also available in die form as the HMC641.

Electrical Specifications, $T_A = +25^\circ\text{C}$, With 0/-5V Control, $V_{SS} = -5\text{V}$, 50 Ohm System

Parameter	Frequency	Min.	Typ.	Max.	Units
Insertion Loss	DC - 12 GHz		1.6	2.8	dB
	DC - 20 GHz		2.3	3.5	dB
Isolation (RFC to RF1 - RF4)	DC - 12 GHz	30	42		dB
	DC - 20 GHz	30	40		dB
Return Loss	"On State"	DC - 12 GHz	18		dB
		DC - 20 GHz	17		dB
Return Loss	"Off State"	DC - 20 GHz	13		dB
Input Power for 1 dB Compression	0.05 - 0.25 GHz	10	15		dBm
	0.25 - 20 GHz	20	23		dBm
Input Third Order Intercept (Two-Tone Input Power= +14 dBm Each Tone)	0.05 - 0.25 GHz		30		dBm
	0.25 - 20 GHz		39		dBm
Switching Characteristics tRISE, tFALL (10/90% RF) tON, tOFF (50% CTL to 10/90% RF)	DC - 20 GHz		15		ns
			88		ns

GaAs MMIC SP4T NON-REFLECTIVE SWITCH, DC - 20 GHz

Insertion Loss vs. Temperature

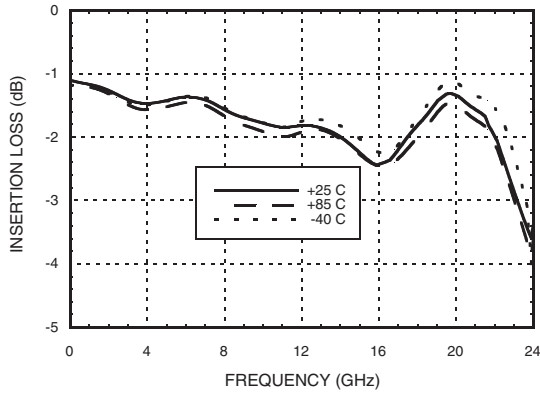

Isolation

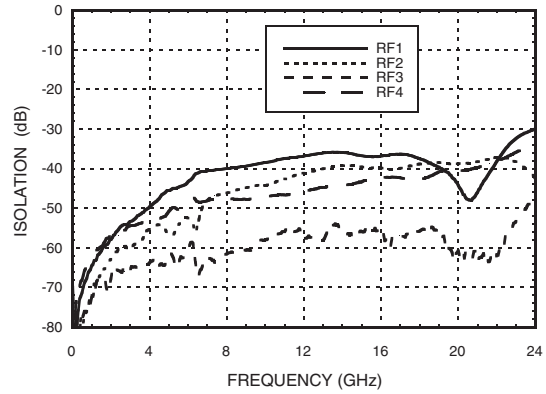

Return Loss

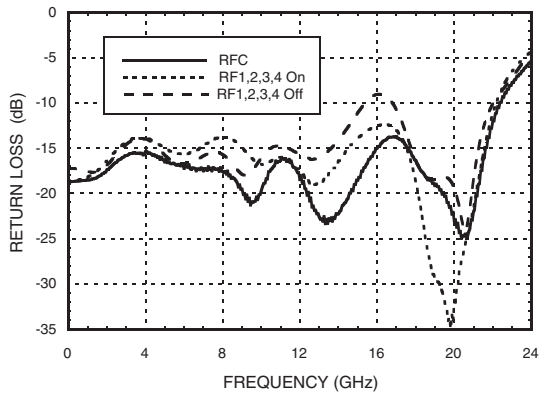

1 dB Input Compression Point

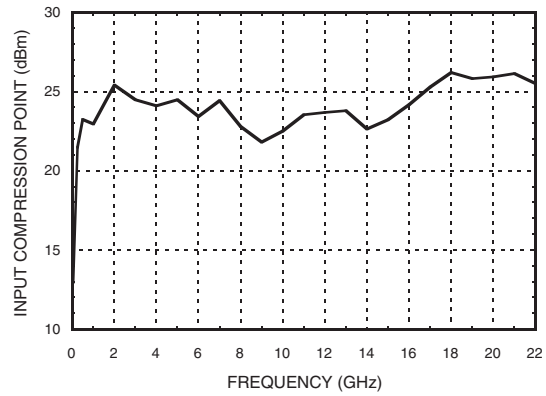

Input Third Order Intercept Point @ 0 dBm Tone Power

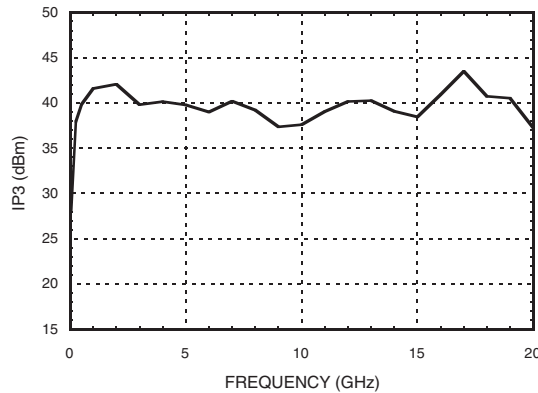

GaAs MMIC SP4T NON-REFLECTIVE SWITCH, DC - 20 GHz

Absolute Maximum Ratings

Bias Voltage (Vss)	-7V
Control Voltage Range (A & B)	Vss -0.5V to +1V
Maximum Input Power	+24 dBm
Channel Temperature	150 °C
Thermal Resistance Channel to die bottom (Insertion Loss Path)	199 °C/W
Thermal Resistance Channel to die bottom (Terminated Path)	219 °C/W
Storage Temperature	-65 to +150 °C
Operating Temperature	-40 to +85 °C
ESD Sensitivity (HBM)	Class 1A

Truth Table

Control Input		Signal Path State
A	B	RFC to:
High	High	RF1
Low	High	RF2
High	Low	RF3
Low	Low	RF4

Bias Voltage & Current

Vss Range= -5.0 Vdc ±10%		
Vss (Vdc)	Iss (Typ) (mA)	Iss (Max) (mA)
-5	1.7	5.0



**ELECTROSTATIC SENSITIVE DEVICE
OBSERVE HANDLING PRECAUTIONS**

TTL/CMOS Control Voltages

State	Bias Condition
Low	-2.5V to 0V @ 30 µA Typ.
High	-5V to -3.8V @ 1.7 µA Typ.

GaAs MMIC SP4T NON-REFLECTIVE SWITCH, DC - 20 GHz

Outline Drawing

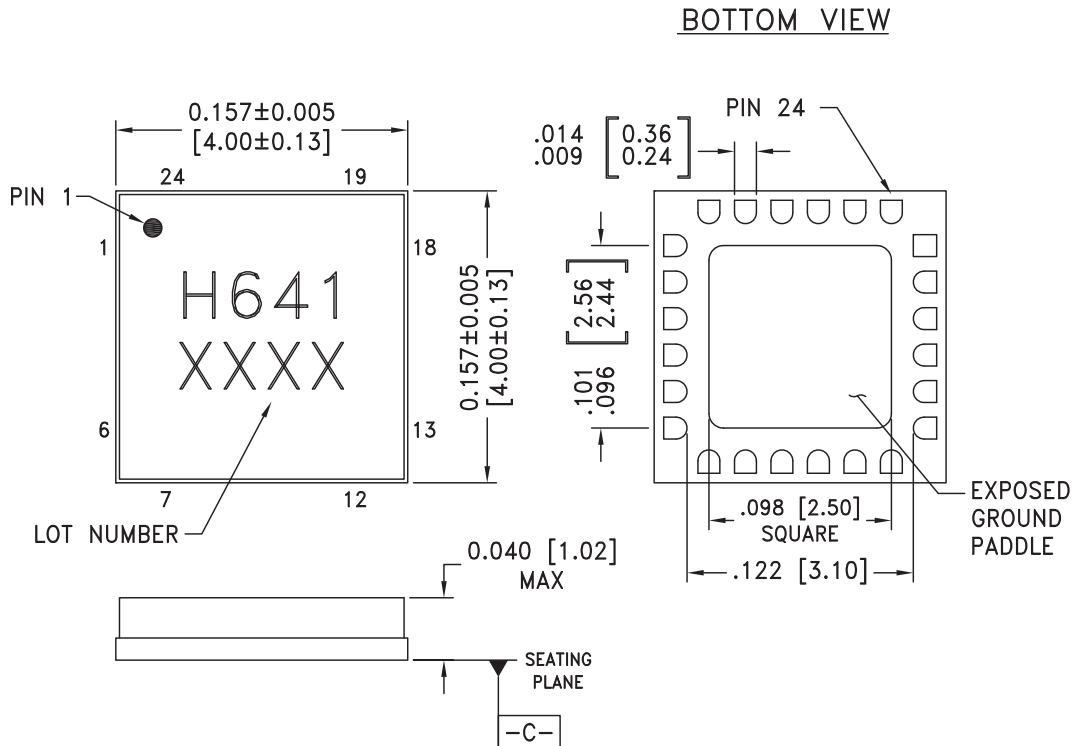

NOTES:

1. PACKAGE BODY MATERIAL: ALUMINA
2. LEAD AND GROUND PADDLE PLATING: 30-80 MICROINCHES GOLD OVER 50 MICROINCHES MINIMUM NICKEL.
3. DIMENSIONS ARE IN INCHES [MILLIMETERS].
4. LEAD SPACING TOLERANCE IS NON-CUMULATIVE
5. PACKAGE WARP SHALL NOT EXCEED 0.05mm DATUM [-C-]
6. ALL GROUND LEADS AND GROUND PADDLE MUST BE SOLDERED TO PCB RF GROUND.
7. CLASSIFIED AS MOISTURE SENSITIVITY LEVEL (MSL) 1.

GaAs MMIC SP4T NON-REFLECTIVE SWITCH, DC - 20 GHz

Pin Descriptions

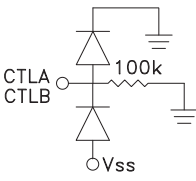
Pin Number	Function	Description	Interface Schematic
1, 5, 6, 13, 18	N/C	These pins are not connected internally; however, all data shown herein was measured with these pins connected to RF/DC ground externally.	
2, 4, 7, 9, 10, 12, 17, 19, 21, 22, 24 Ground Paddle	GND	These pins and the exposed ground paddle must be connected to RF/DC ground.	
3, 8, 11, 20, 23	RFC, RF1, RF2, RF3, RF4	These pads are DC coupled and matched to 50 Ohms. Blocking capacitors are required if RF line potential is not equal to 0V.	
14	Vss	Supply Voltage -5 Vdc ± 10%.	
15	CTLB	See Truth Table and Control Voltage Table.	
16	CTLA	See Truth Table and Control Voltage Table.	

GaAs MMIC SP4T NON-REFLECTIVE SWITCH, DC - 20 GHz

Evaluation PCB

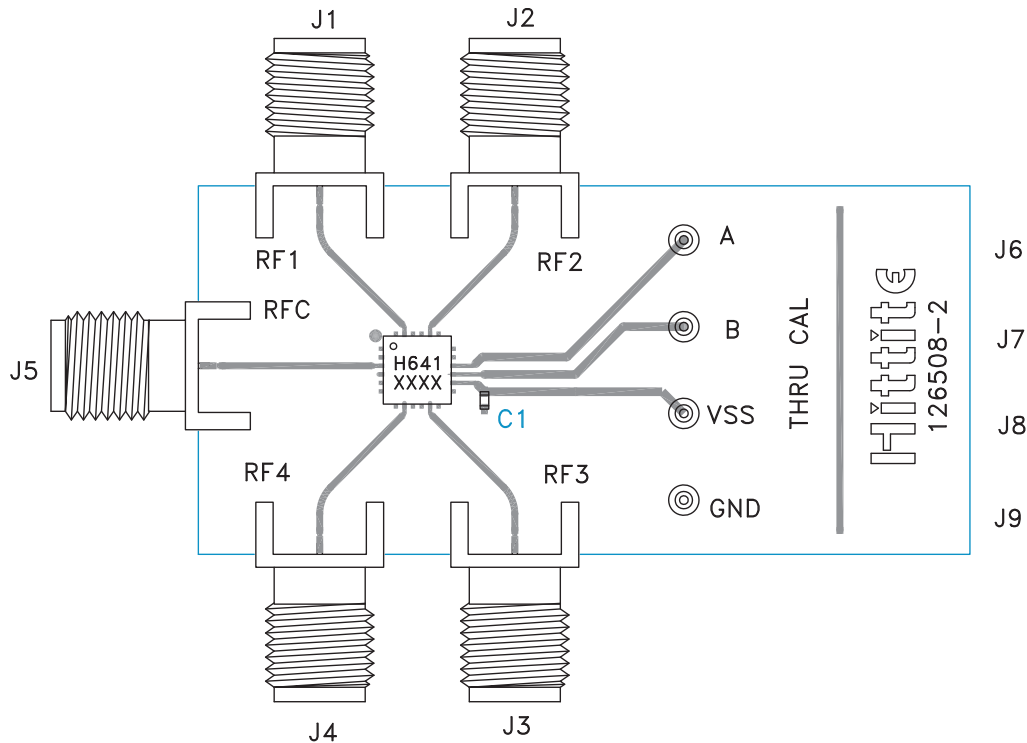

List of Materials for Evaluation PCB 126511 [1]

Item	Description
J1 - J5	PCB Mount SMA Connector
C1	1000 pF Capacitor, 0402 Pkg.
U1	HMC641LC4 Switch
PCB [2]	126508 Evaluation PCB

[1] Reference this number when ordering complete evaluation PCB

[2] Circuit Board Material: Rogers 4350 or Arlon FR4

The circuit board used in the application should use RF circuit design techniques. Signal lines should have 50 Ohm impedance while the package ground leads and exposed paddle should be connected directly to the ground plane similar to that shown. A sufficient number of via holes should be used to connect the top and bottom ground planes. The evaluation board should be mounted to an appropriate heat sink. The evaluation circuit board shown is available from Hittite upon request.