

Typical Applications

The HMC641LP4E is ideal for:

- Telecom Infrastructure
- Microwave Radio & VSAT
- Military & Space Hybrids
- Test Instrumentation
- SATCOM & Sensors

Functional Diagram

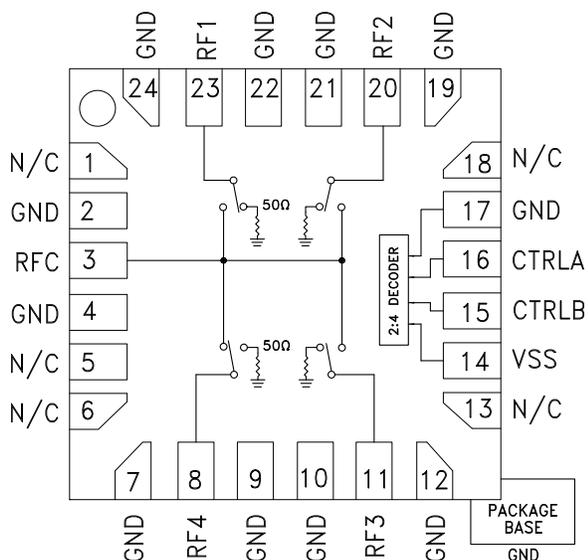

Features

- Broadband Performance: DC - 20 GHz
- High Isolation: 45 dB @ 10 GHz
- Low Insertion Loss: 2.3 dB @ 10 GHz
- Integrated 2:4 TTL Decoder
- 24 Lead 4x4 mm SMT Package: 16 mm²

General Description

The HMC641LP4E is a broadband non-reflective GaAs pHEMT SP4T switch in a compact 4x4 mm plastic package. Covering DC to 20 GHz, this switch offers high isolation, low insertion loss and on-chip termination of isolated ports. This switch also includes an on board binary decoder circuit which reduces the number of required logic control lines from four to two. The HMC641LP4E is controlled with 0/ -5V logic, exhibits fast switching speed and consumes much less DC current than pin diode based solutions. The HMC641LP4E is also available in die form as the HMC641.

Electrical Specifications, $T_A = +25^\circ\text{C}$, With 0/-5V Control, $V_{SS} = -5\text{V}$, 50 Ohm System

Parameter	Frequency	Min.	Typ.	Max.	Units
Insertion Loss	DC - 12 GHz		2.0	3.2	dB
	DC - 20 GHz		3.0	4.2	dB
Isolation (RFC to RF1 - RF4)	DC - 12 GHz	30	42		dB
	DC - 20 GHz	30	40		dB
Return Loss	"On State"	DC - 12 GHz	18		dB
		DC - 20 GHz	17		dB
Return Loss	"Off State"	DC - 20 GHz	13		dB
Input Power for 1 dB Compression	0.05 - 0.25 GHz	10	15		dBm
	0.25 - 20 GHz	20	22		dBm
Input Third Order Intercept (Two-Tone Input Power= +14 dBm Each Tone)	0.05 - 0.25 GHz		30		dBm
	0.25 - 20 GHz		38		dBm
Switching Characteristics tRISE, tFALL (10/90% RF) tON, tOFF (50% CTL to 10/90% RF)	DC - 20 GHz		15		ns
			88		ns

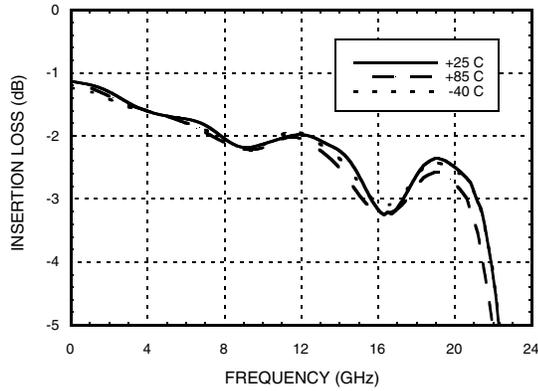
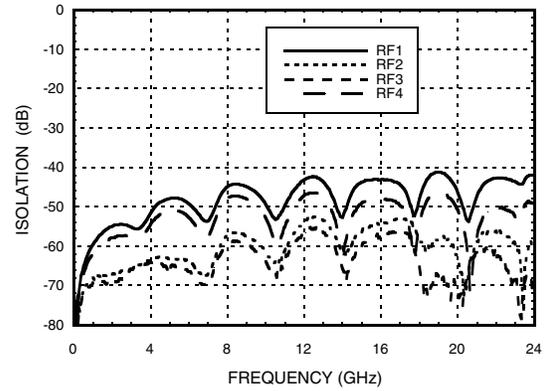
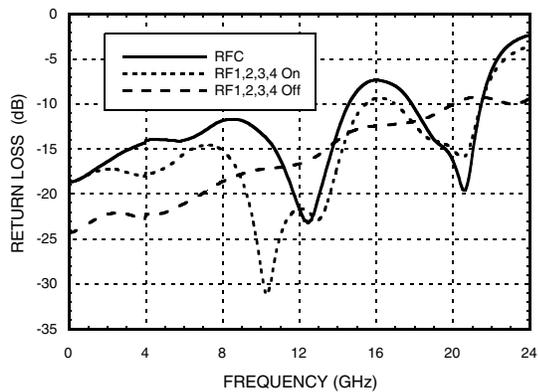
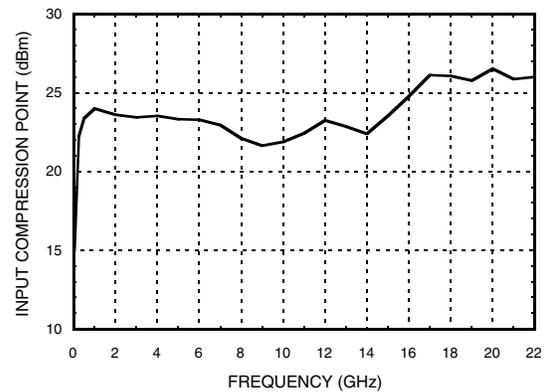
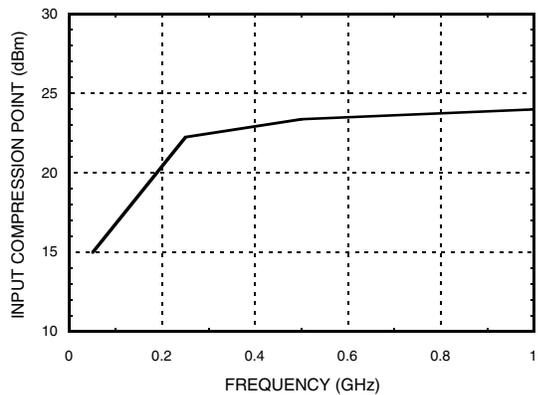
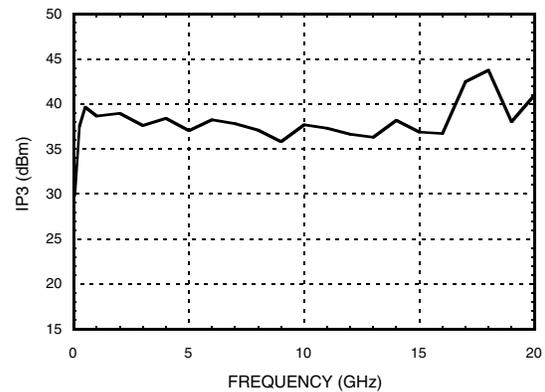
GaAs MMIC SP4T NON-REFLECTIVE SWITCH, DC - 20 GHz
Insertion Loss vs. Temperature

Isolation

Return Loss

1 dB Input Compression Point

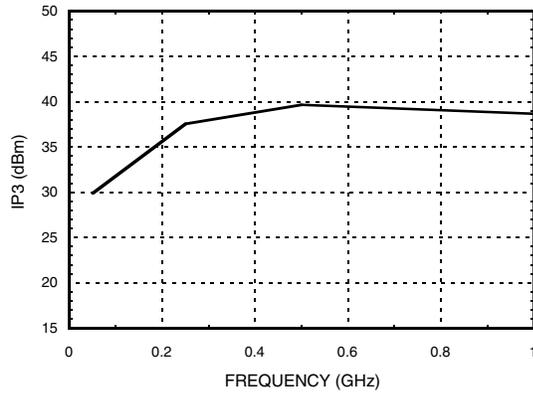
1 dB Input Compression Point (Low Frequency Detail)

Input Third Order Intercept Point @ 0 dBm Tone Power



GaAs MMIC SP4T NON-REFLECTIVE SWITCH, DC - 20 GHz

Input Third Order Intercept (Low Frequency Detail)



Absolute Maximum Ratings

Bias Voltage (Vss)	-7V
Control Voltage Range (CTRLA & CTRLB)	Vss -1V to +1V
Maximum Input Power	+24 dBm
Channel Temperature	150 °C
Thermal Resistance Channel to ground paddle (Insertion Loss Path)	199 °C/W
Thermal Resistance Channel to ground paddle (Terminated Path)	219 °C/W
Storage Temperature	-65 to +150 °C
Operating Temperature	-40 to +85 °C
ESD Sensitivity (HBM)	Class 1A



ELECTROSTATIC SENSITIVE DEVICE
OBSERVE HANDLING PRECAUTIONS

Truth Table

Control Input		Signal Path State
CTRLA	CTRLB	RFC to:
High	High	RF1
Low	High	RF2
High	Low	RF3
Low	Low	RF4

Bias Voltage & Current

Vss Range = -5 Vdc ±10%		
Vss (Vdc)	Iss (Typ) (mA)	Iss (Max) (mA)
-5	1.7	5.0

TTL/CMOS Control Voltages

State	Bias Condition
Low	-2.5V to 0V @ 30 µA Typ.
High	-5V to -3.8V @ 1.7 µA Typ.

Outline Drawing

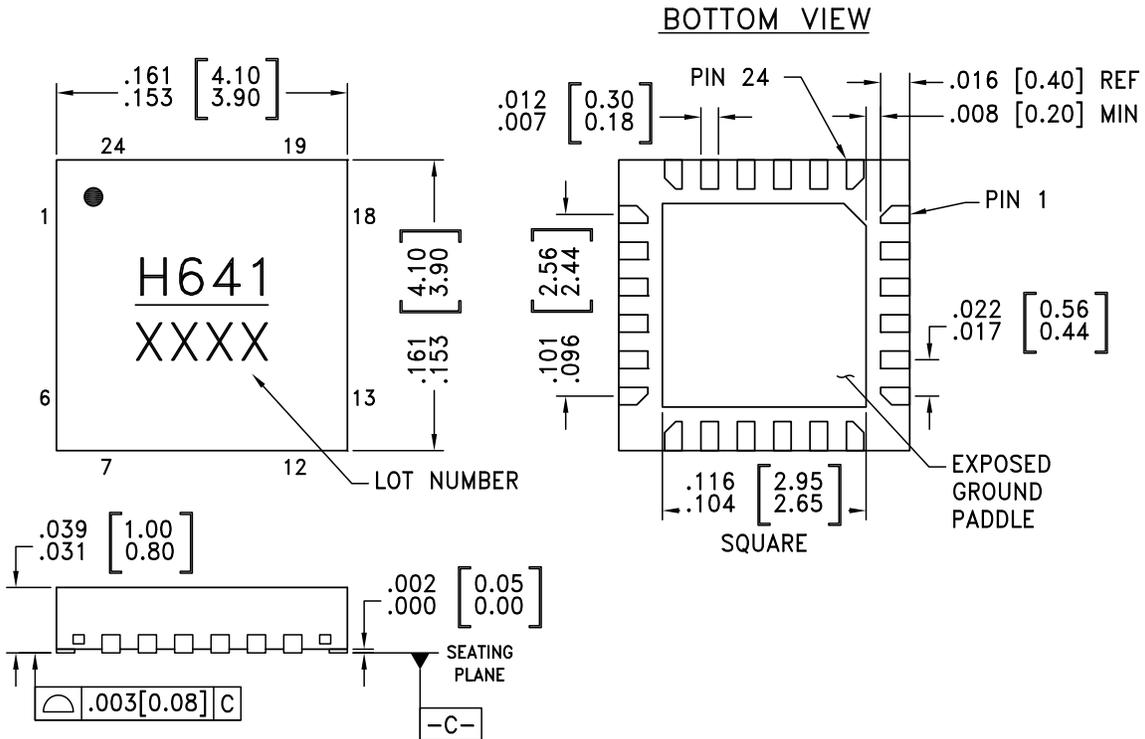

NOTES:

1. LEADFRAME MATERIAL: COPPER ALLOY
2. DIMENSIONS ARE IN INCHES [MILLIMETERS]
3. LEAD SPACING TOLERANCE IS NON-CUMULATIVE
4. PAD BURR LENGTH SHALL BE 0.15 mm MAXIMUM.
PAD BURR HEIGHT SHALL BE 0.05 mm MAXIMUM.
5. PACKAGE WARP SHALL NOT EXCEED 0.05 mm.
6. ALL GROUND LEADS AND GROUND PADDLE MUST BE SOLDERED TO PCB RF GROUND.
7. REFER TO HITTITE APPLICATION NOTE FOR SUGGESTED LAND PATTERN.

Package Information

Part Number	Package Body Material	Lead Finish	MSL Rating	Package Marking ^[1]
HMC641LP4E	RoHS-compliant Low Stress Injection Molded Plastic	100% matte Sn	MSL1 ^[2]	H641 XXXX

[1] 4-Digit lot number XXXX

[2] Max peak reflow temperature of 260 °C

GaAs MMIC SP4T NON-REFLECTIVE SWITCH, DC - 20 GHz
Pin Descriptions

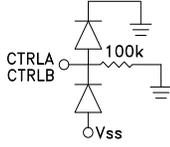
Pin Number	Function	Description	Interface Schematic
1, 5, 6, 13, 18	N/C	These pins are not connected internally; however, all data shown herein was measured with these pins connected to RF/DC ground externally.	
2, 4, 7, 9, 10, 12, 17, 19, 21, 22, 24 Ground Paddle	GND	These pins and the exposed ground paddle must be connected to RF/DC ground.	
3	RFC	This pin is DC coupled and matched to 50 Ohms. A blocking capacitor is required if RF line potential is not equal to 0V.	
8	RF4	This pin is DC coupled and matched to 50 Ohms. A blocking capacitor is required if RF line potential is not equal to 0V.	
11	RF3	This pin is DC coupled and matched to 50 Ohms. A blocking capacitor is required if RF line potential is not equal to 0V.	
14	Vss	Supply Voltage -5 Vdc ± 10%.	
15	CTRLB	See Truth Table and Control Voltage Table.	
16	CTRLA	See Truth Table and Control Voltage Table.	
20	RF2	This pin is DC coupled and matched to 50 Ohms. A blocking capacitor is required if RF line potential is not equal to 0V.	
23	RF1	This pin is DC coupled and matched to 50 Ohms. A blocking capacitor is required if RF line potential is not equal to 0V.	

Evaluation PCB

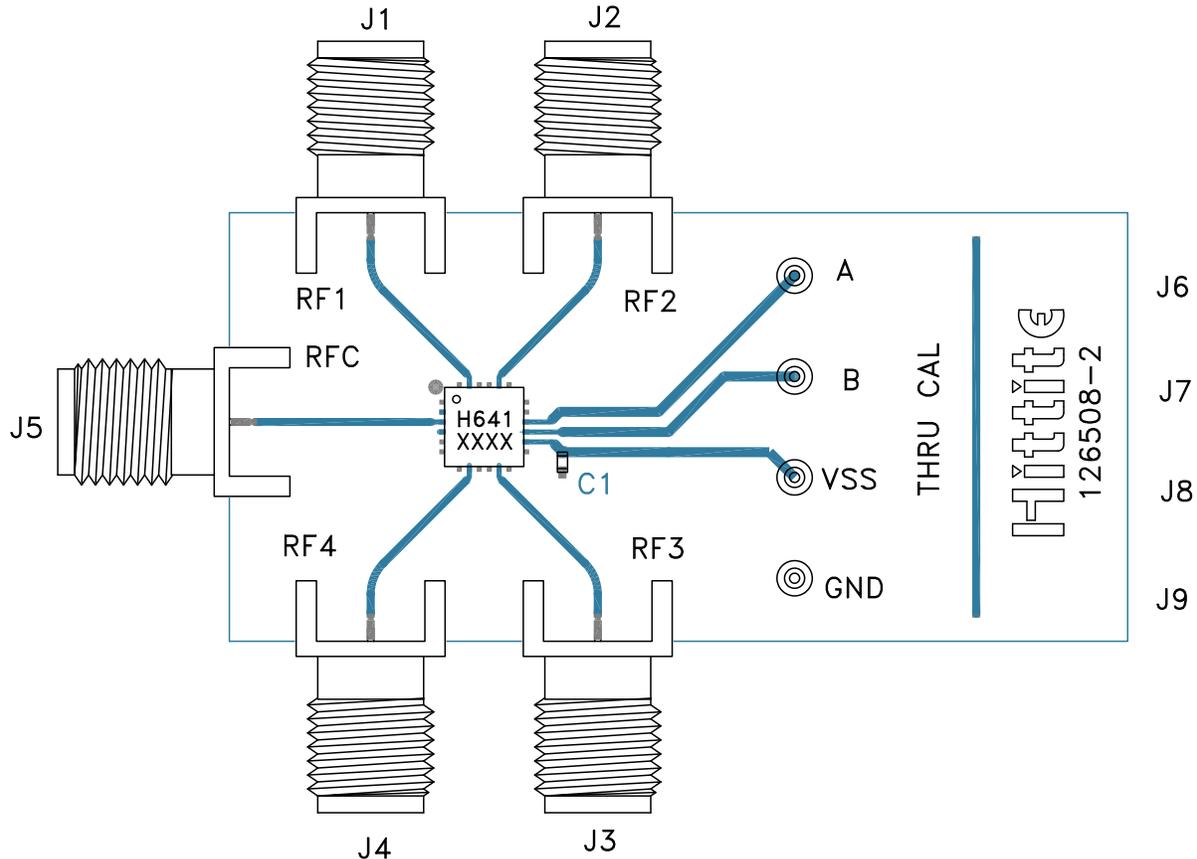

List of Materials for Evaluation PCB 126511 ^[1]

Item	Description
J1 - J5	PCB Mount SMA Connector
J6 - J9	DC Pin
C1	1000 pF Capacitor, 0402 Pkg.
U1	HMC641LP4E Switch
PCB ^[2]	126508 Evaluation PCB

[1] Reference this number when ordering complete evaluation PCB

[2] Circuit Board Material: Rogers 4350 or Arlon FR4

The circuit board used in the application should use RF circuit design techniques. Signal lines should have 50 Ohm impedance while the package ground leads and exposed paddle should be connected directly to the ground plane similar to that shown. A sufficient number of via holes should be used to connect the top and bottom ground planes. The evaluation board should be mounted to an appropriate heat sink. The evaluation circuit board shown is available from Hittite upon request.