

# Type SSQC & SSTC

RoHS 6 Compliant

2410 size SMD fuses, pre-assembled in SMD clips



RoHS6 Compliant

Conflict free metals



These fuse/clip assemblies can be efficiently placed in a single pass. Once reflowed, fuse replacement requires no resoldering.

### Electrical Specification

Maximum Recommended Fuse Current Rating 8Amperes,125Volts. Use of SSQ fuses rated higher than 8A, i.e. 10A, 12A, 15A may be suitable with proper evaluation. (Consult with Bel engineering)

### Environmental Specification

Operating Temperature	-55 °C to +125 °C
Shock Resistance	MIL-STD-202G, Method 213B, Test Condition I (100 G's peak for 6 milliseconds; Sawtooth Waveform)
Vibration Resistance	MIL-STD-202G, Method 201A (10-55 Hz, 0.06 inch, total excursion).
Solderability	MIL-STD-202G, Method 208H
Insulation Resistance	MIL-STD-202, Method 302, Test Condition A (After Opening) 10,000 ohms minimum.
Thermal Shock	MIL-STD-202G, Method 107G, Test Condition B (-65 °C to +125 °C).

### Features

- Surface mount, 2410 assembly
- Allows solderless field replacement of open fuse
- Available in rating of SSQC 250mA to 8A and SSTC 375mA to 7A
- Wide operating temperature range
- Tape and Reel for automatic placement

### Applications

- Notebook
- LCD monitor
- PC computer
- Office electronic equipment
- Industrial equipment
- Medical equipment
- POE, POE+
- LCD / LED monitor
- Power supply
- LCD / LED TV

HALOGEN FREE = **HF**

LEAD FREE = **Pb**

### RoHS 6 Compliant Product

Lead-free IR Reflow Profile (IPC/JEDEC J-STD-020D)	
Reflow Parameter	
Minimum preheat temperature (TsMIN)	150°C
Maximum preheat temperature (TsMAX)	200°C
Preheat Time	60-180 seconds
TsMAX to TL ramp-up rate	3°C / second max.
Time above temperature TL (TL)	217 °C 60-120 seconds
Peak Temperature (TP)	260 °C max.
Time Within +0 °C / -5 °C of Peak TP	20 - 40 seconds.
Ramp-down rate	6°C / second max.

SSQ Square Ceramic Surface mount Quick Action Fuse	
Catalog Number	Ampere Rating
SSQC 250	250mA
SSQC 375	375mA
SSQC 500	500mA
SSQC 750	750mA
SSQC 1	1A
SSQC 1.25	1.25A
SSQC 1.5	1.5A
SSQC 2	2A
SSQC 2.5	2.5A
SSQC 3	3A
SSQC 3.5	3.5A
SSQC 4	4A
SSQC 5	5A
SSQC 6.3	6.3A
SSQC 7	7A
SSQC 8	8A

Consult manufacturer for other ratings

SST Square Ceramic Surface mount Slow Blow Fuse	
Catalog Number	Ampere Rating
SSTC 375	375mA
SSTC 500	500mA
SSTC 625	625mA
SSTC 750	750mA
SSTC 1	1A
SSTC 1.5	1.5A
SSTC 2	2A
SSTC 2.5	2.5A
SSTC 3	3A
SSTC 3.5	3.5A
SSTC 4	4A
SSTC 5	5A
SSTC 7	7A

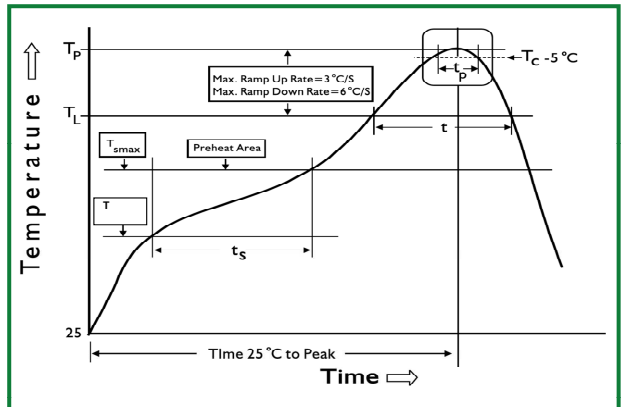

### Physical Specification

Materials	Clip Terminals: Matte Tin Plated Inconel Alloy
-----------	--

Specifications Subject to change without notice.

### Packaging

Packaging Tape & Reel	Packaging Specification	Quantity	Part Number Code	Type
16 mm wide tape, 8mm pitch with 7 inches Diameter reel	EIA Standard 481-D	500	0679-XXXX-12	SSQC
16 mm wide tape, 8mm pitch with 7 inches Diameter reel	EIA Standard 481-D	500	0680-XXXX-12	SSTC

### Mechanical Dimensions

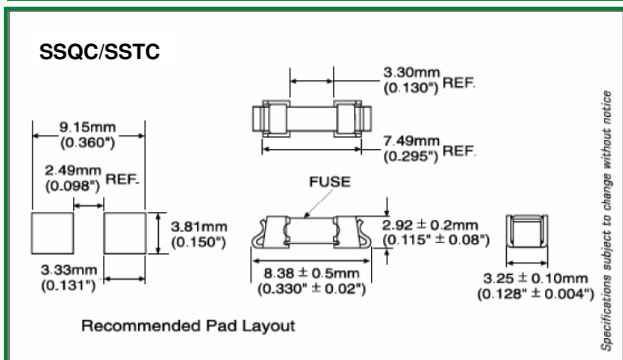

Specifications subject to change without notice