

Typical Applications

The HMC940LC4B is ideal for:

- RF ATE Applications
- Broadband Test & Measurement
- Serial Data Transmission up to 13 Gbps
- Clock Buffering up to 13 GHz

Features

- Inputs Terminated Internally in 50 Ohms
- Differential Inputs are DC Coupled
- Propagation Delay: 101 ps
- Fast Rise and Fall Times: 26 / 25 ps
- Programmable Differential Output Voltage Swing: 600 - 1400 mV
- Power Dissipation: 440 mW
- 24 Lead Ceramic 4x4 mm SMT Package: 16 mm²

Functional Diagram

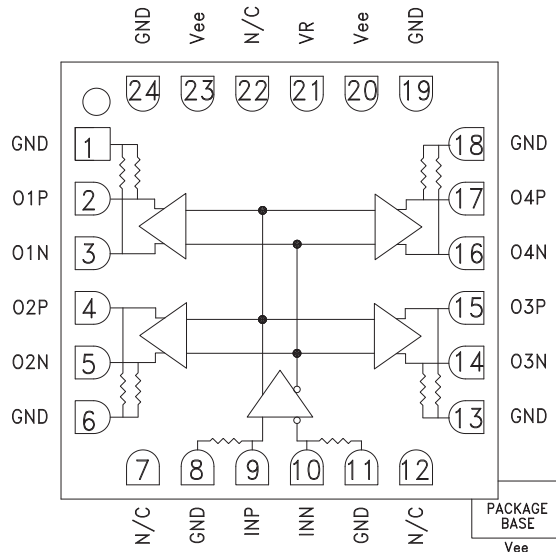

General Description

The HMC940LC4B is a 1:4 Fanout Buffer designed to support data transmission rates up to 13 Gbps, and clock frequencies as high as 13 GHz. All differential inputs and outputs are DC coupled and terminated on chip with 50 Ohm resistors to ground. The outputs may be used in either single-ended or differential modes, and should be AC or DC coupled into 50 Ohm resistors connected to ground.

The HMC940LC4B also features an output level control pin, VR which allows for loss compensation or for signal level optimization. The HMC940LC4B operates from a single -3.3V DC supply and is available in a ceramic RoHS compliant 4x4 mm SMT package.

Electrical Specifications, $T_A = +25\text{ }^\circ\text{C}$, $V_{ee} = -3.3\text{V}$, $VR = 0\text{V}$

| Parameter | Conditions | Min. | Typ. | Max | Units |
|---|----------------------------|------|---------|------|-------|
| Power Supply Voltage (V _{ee}) | | -3.6 | -3.3 | -3.0 | V |
| Power Supply Current | | | 133 | | mA |
| Maximum Data Rate | | | 13 | | Gbps |
| Maximum Clock Rate | | | 13 | | GHz |
| Input High Voltage | | -0.5 | | 0.5 | V |
| Input Low Voltage | | -1.0 | | 0.0 | V |
| Input Return Loss | Frequency <15 GHz | | 10 | | dB |
| Output Amplitude | Single-Ended, peak-to-peak | | 585 | | mVp-p |
| | Differential, peak-to-peak | | 1170 | | mVp-p |
| Output High Voltage | | | -15 | | mV |
| Output Low Voltage | | | -600 | | mV |
| Output Rise / Fall Time | Single-Ended, 20% - 80% | | 26 / 25 | | ps |



**13 Gbps, 1:4 FANOUT BUFFER
w/ PROGRAMMABLE OUTPUT VOLTAGE**

Electrical Specifications, (continued)

| Parameter | Conditions | Min. | Typ. | Max | Units |
|--------------------------------|---|------|---------|-----|--------|
| Output Return Loss | Frequency <13 GHz | | 10 | | dB |
| Small Signal Gain | | | 20 | | dB |
| Random Jitter J_R | rms | | | 0.2 | ps rms |
| Deterministic Jitter, J_D | $\delta - \delta$, $2^{15}-1$ PRBS input [1] | | 4 | 6 | ps |
| Propagation Delay, t_d | | | 101 | | ps |
| D1 to D2 Data Skew, t_{SKEW} | | | ± 3 | | ps |

[1] Deterministic jitter measured at 13 Gbps with a 300 mVp-p, $2^{15}-1$ PRBS input sequence.

DC Current vs. Supply Voltage [1] [2]

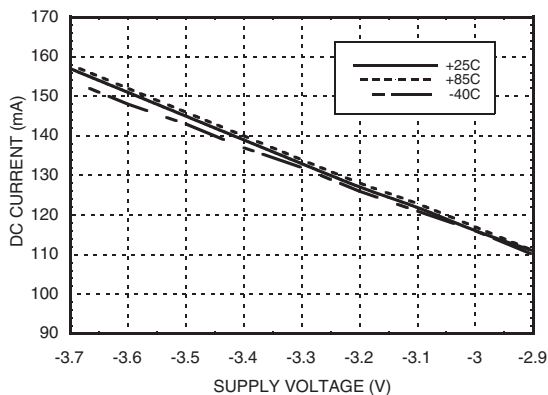

Output Differential vs. Supply Voltage [1] [2]

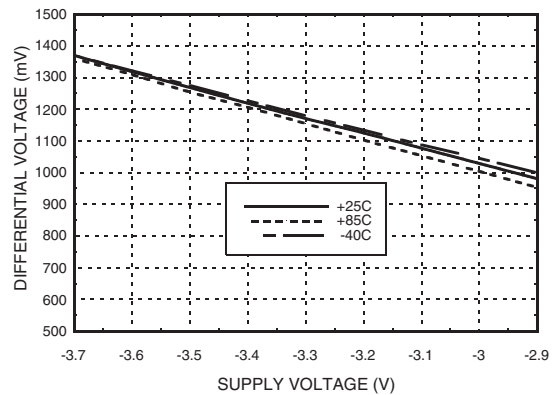

Output Differential vs. VR [2][3]

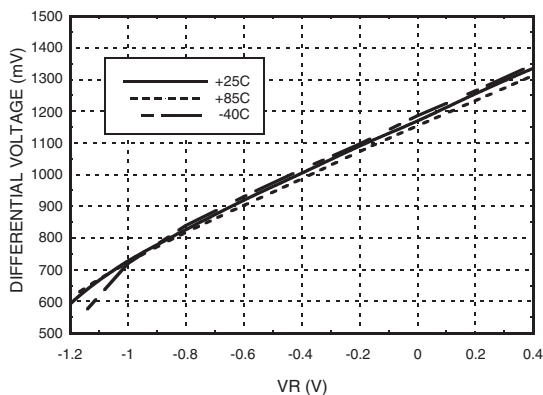

DC Current vs. VR [2][3]

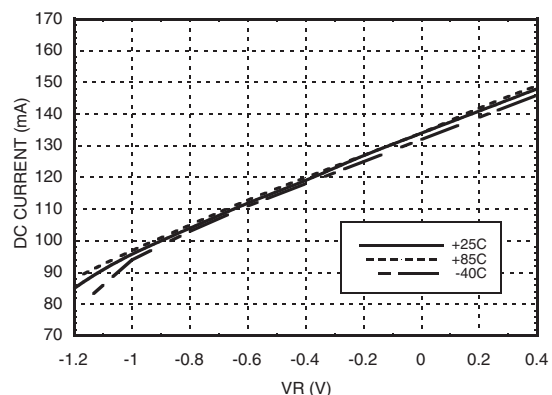

[1] VR = 0.0V

[2] Frequency = 13 GHz

[3] Vee = -3.3V

13 Gbps, 1:4 FANOUT BUFFER w/ PROGRAMMABLE OUTPUT VOLTAGE

3

HIGH SPEED LOGIC - SMT

Rise / Fall Time vs. Supply Voltage [1][2]

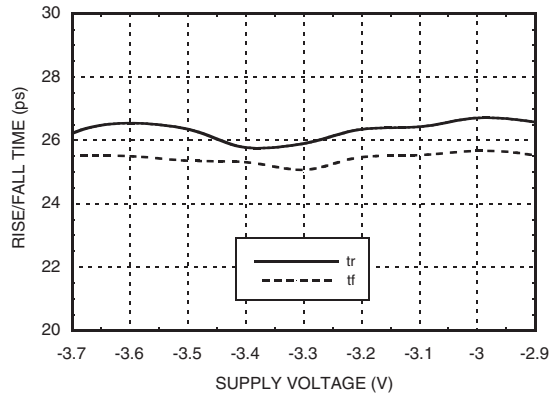

Rise / Fall Time vs. VR [2][5]

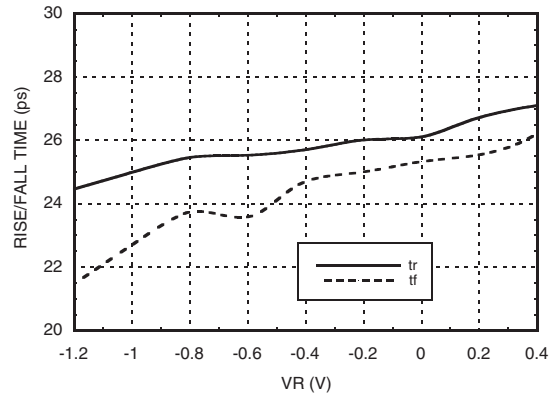

Input Return Loss vs. Frequency [1][3][5]

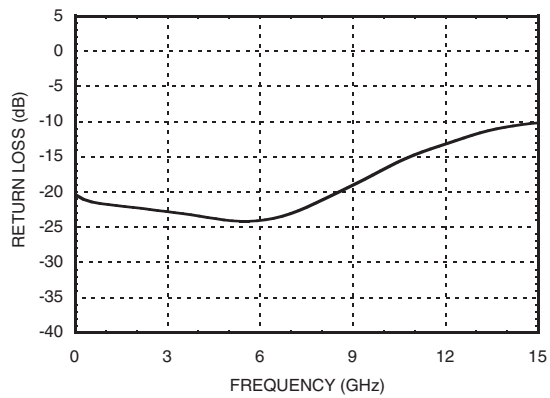

Output Return Loss vs. Frequency [1][3][5]

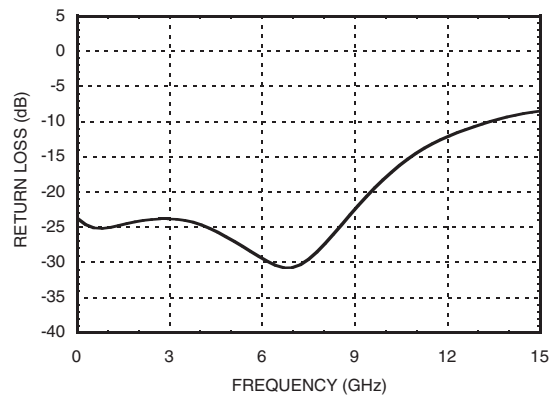

Amplitude vs. Input Power [1][4][5]

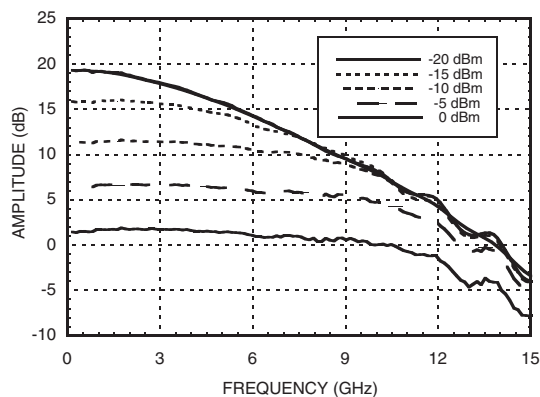

Truth Table

| Input | Outputs |
|-------|---------|
| IN | Ox |
| L | L |
| H | H |

Notes:
 IN = INP - INN
 Ox = OxP - OxN
 H - Positive differential voltage
 L - Negative differential voltage

[1] VR = 0.0V [2] Frequency = 13 GHz [3] Device measured on evaluation board with gating after connector
 [4] Device measured on evaluation board with port extensions [5] Vee = -3.3V

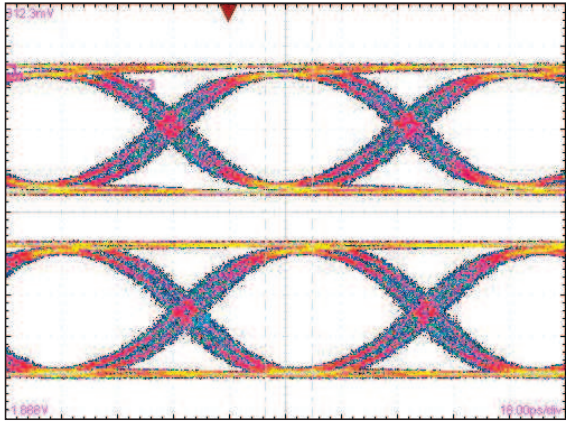
**13 Gbps, 1:4 FANOUT BUFFER
w/ PROGRAMMABLE OUTPUT VOLTAGE**
Eye Diagram

[1] Test Conditions:

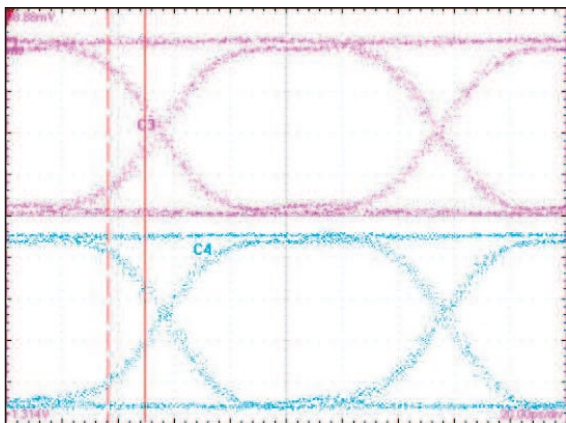
Pattern generated with an Agilent N4903A Serial BERT.
 Eye Diagram presented on a Tektronix CSA 8000.
 Device input = 13 Gbps PN code, $V_{in} = 300$ mVp-p differential.
 Both output channels shown.

Eye Diagram

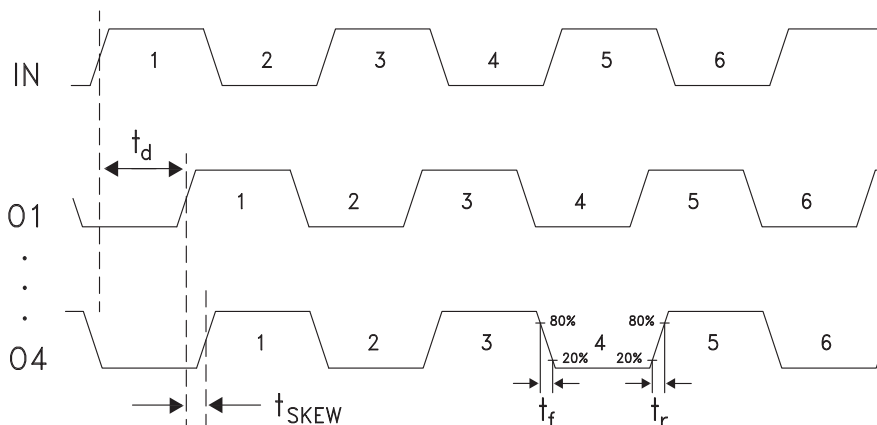
[2] Test Conditions:

Pattern generated with an Agilent N4903A Serial BERT.
 Eye Diagram presented on a Tektronix CSA 8000.
 Device input = 10 Gbps PN code, $V_{in} = 300$ mVp-p differential.
 Both output channels shown.

Timing Diagram



13 Gbps, 1:4 FANOUT BUFFER w/ PROGRAMMABLE OUTPUT VOLTAGE

Absolute Maximum Ratings

| | |
|---|-------------------|
| Power Supply Voltage (Vee) | -3.75V to +0.5V |
| Input Signals | -2V to +0.5V |
| Output Signals | -1.5V to +1V |
| Junction Temperature | 125 °C |
| Continuous Pdiss (T=85 °C) (derate 30 mW/°C above 85 °C) | 1.22 W |
| Thermal Resistance (R _{th j-p}) Worse case junction to package paddle | 32.8 °C/W |
| Storage Temperature | -65 °C to +150 °C |
| Operating Temperature | -40 °C to +85 °C |



ELECTROSTATIC SENSITIVE DEVICE
OBSERVE HANDLING PRECAUTIONS

3

HIGH SPEED LOGIC - SMT

Outline Drawing

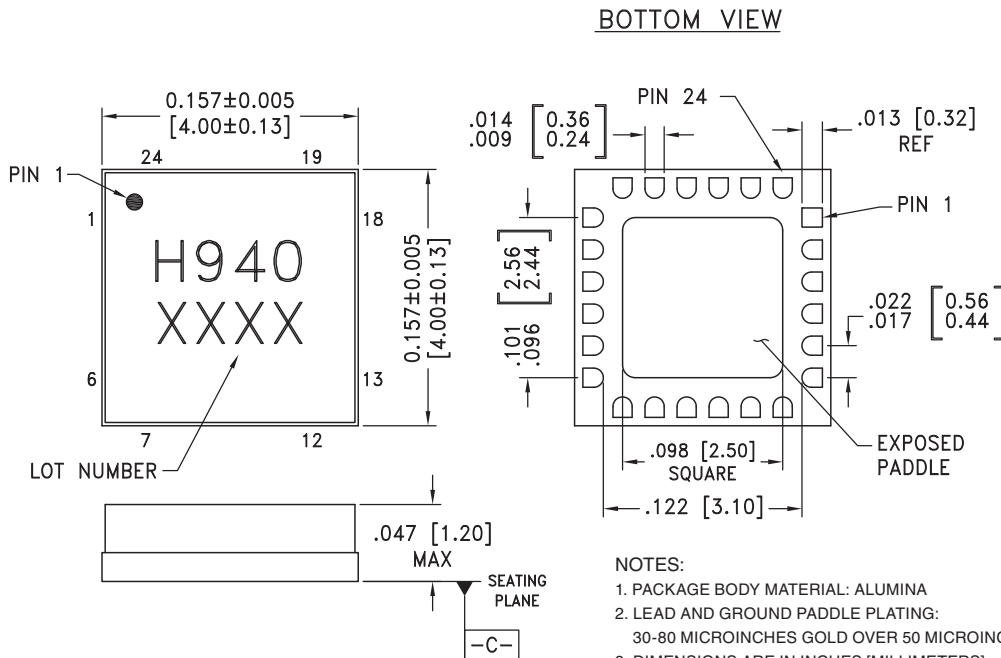



13 Gbps, 1:4 FANOUT BUFFER w/ PROGRAMMABLE OUTPUT VOLTAGE

Pin Descriptions

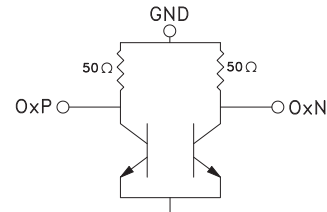
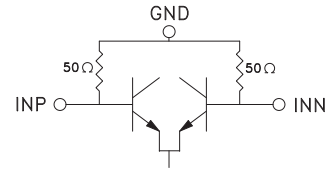
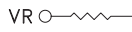
| Pin Number | Function | Description | Interface Schematic |
|-----------------------------|--|--|---|
| 1, 6, 8, 11, 13, 18, 19, 24 | GND | These pins must be connected to a high quality RF/DC ground. |  |
| 2, 3, 4, 5, 14, 15, 16, 17 | O1P, O1N, O2P, O2N, O3N, O3P, O4N, O4P | Differential Outputs: Current Mode Logic (CML) referenced to positive supply. |  |
| 7, 12, 22 | N/C | The pins are not connected internally; however, all data shown herein was measured with these pins connected to RF/DC ground externally. | |
| 9, 10 | INP, INN | Differential Inputs: Current Mode Logic (CML) referenced to positive supply |  |
| 20, 23 Package Base | Vee | These pins and the exposed paddle must be connected to the negative voltage supply. | |
| 21 | VR | Output level control. Output level may be increased or decreased by applying a voltage to VR per "Output Differential vs. VR" plot. |  |

13 Gbps, 1:4 FANOUT BUFFER w/ PROGRAMMABLE OUTPUT VOLTAGE

Evaluation PCB

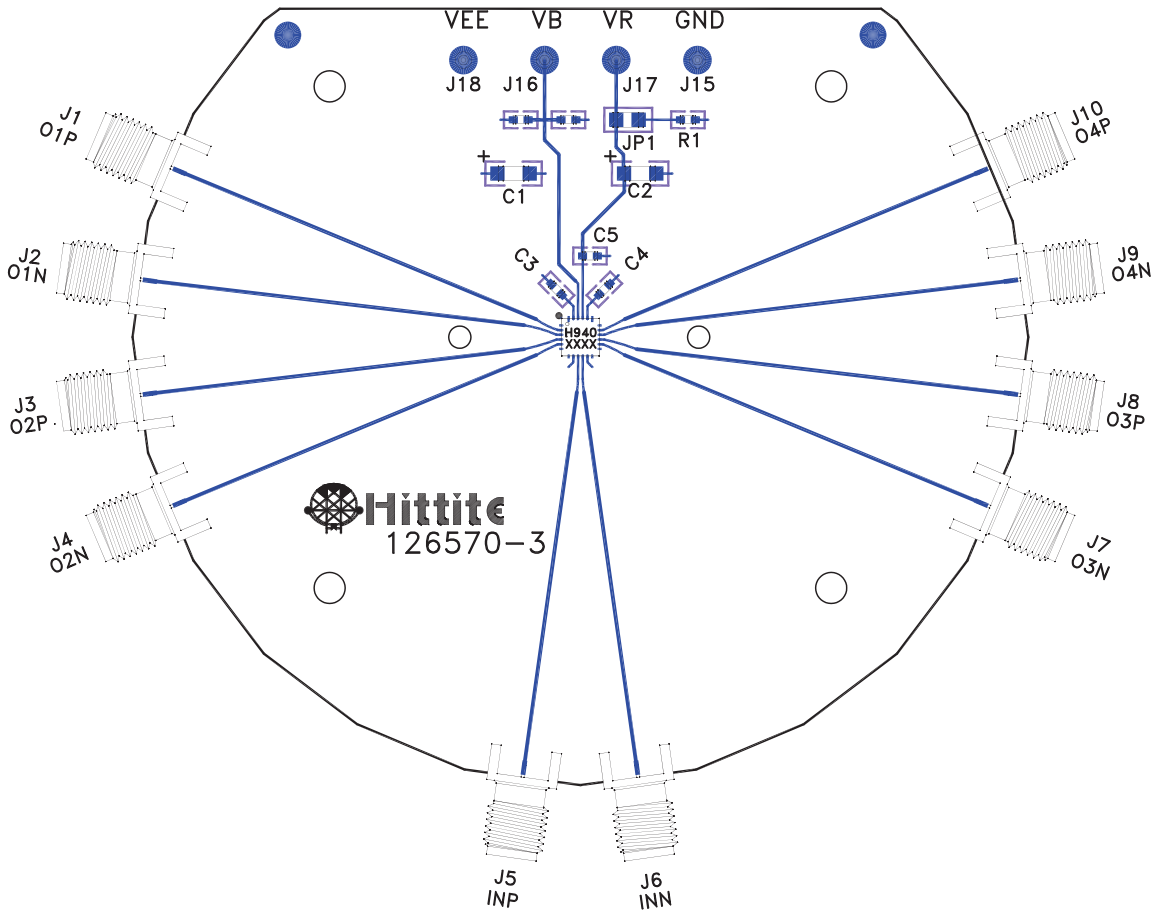

List of Materials for Evaluation PCB 126572 [1]

| Item | Description |
|-----------|--|
| J1 - J10 | PCB Mount SMA RF Connectors |
| J15 - J18 | DC Pin |
| JP1 | 0.1" Header with Shorting Jumper |
| C1, C2 | 4.7 μ F Capacitor, Tantalum |
| C3 - C5 | 100 pF, Capacitor, 0603 Pkg |
| R1 | 10 Ohm Resistor, 0603 Pkg. |
| U1 | HMC940LC4B High Speed Logic, Fanout Buffer |
| PCB [2] | 126570 Evaluation Board |

[1] Reference this number when ordering complete evaluation PCB

[2] Circuit Board Material: Arlon 25FR or Rogers 4350

The circuit board used in the application should use RF circuit design techniques. Signal lines should have 50 Ohm impedance while the package ground leads should be connected directly to the ground plane similar to that shown. The exposed packaged base should be connected to Vee. A sufficient number of via holes should be used to connect the top and bottom ground planes. The evaluation circuit board shown is available from Hittite upon request. Install jumper on JP1 to short VR to GND for normal operation.



13 Gbps, 1:4 FANOUT BUFFER w/ PROGRAMMABLE OUTPUT VOLTAGE

Application Circuit

