

## GaAs HEMT MMIC WIDEBAND LOW NOISE AMPLIFIER, 2 - 20 GHz

### Typical Applications

This HMC-ALH102 is ideal for:

- Wideband Communications Receivers
- Surveillance Systems
- Point-to-Point Radios
- Point-to-Multi-Point Radios
- Military & Space
- Test Instrumentation

### Features

- Noise Figure: 2.5 dB
- Gain: 11.6 dB @ 10 GHz
- P1dB Output Power: +10 dBm
- Supply Voltage: +2V @ 55 mA
- Die Size: 3.0 x 1.435 x 0.1 mm

### Functional Diagram

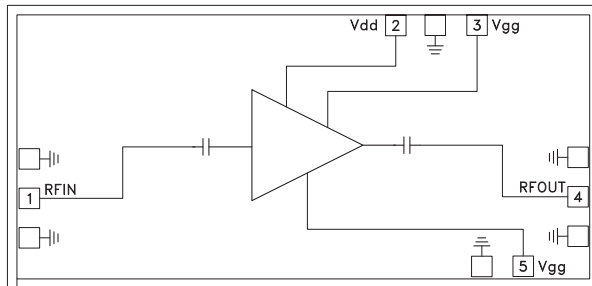

### General Description

The HMC-ALH102 is a GaAs MMIC HEMT Low Noise Distributed Amplifier die which operates between 2 and 20 GHz. The amplifier provides 11.6 dB of gain at 10 GHz, 2.5 dB noise figure and +10 dBm of output power at 1 dB gain compression while requiring only 55 mA from a +2V supply voltage. The HMC-ALH102 amplifier is ideal for integration into Multi-Chip-Modules (MCMs) due to its small size.

### Electrical Specifications, $T_A = +25^\circ\text{C}$ , $V_{dd} = 2\text{V}^{[1]}$ , $I_{dd} = 55\text{mA}^{[2]}$

Parameter	Min.	Typ.	Max.	Units
Frequency Range	2 - 20			GHz
Gain	8	10		dB
Input Return Loss		15		dB
Output Return Loss		12		dB
Output Power for 1 dB Compression	8	10		dBm
Noise Figure		2.5		dB
Supply Current ( $I_{dd}$ )		55		mA

[1] Unless otherwise indicated, all measurements are from probed die

[2] Adjust Vgg between -1V to +0.3V (Typ. -0.5V) to achieve  $I_{dd} = 55\text{ mA}$

## GaAs HEMT MMIC WIDEBAND LOW NOISE AMPLIFIER, 2 - 20 GHz

**Linear Gain vs. Frequency**

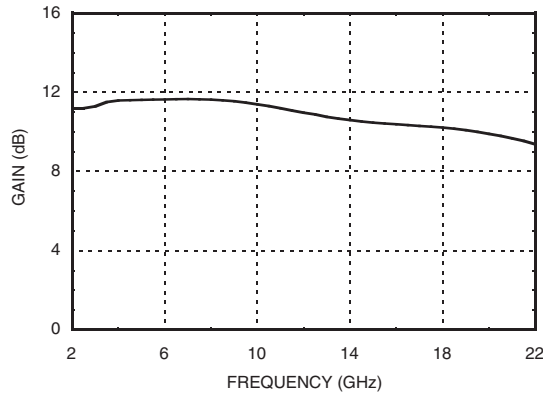

**Noise Figure vs. Frequency**

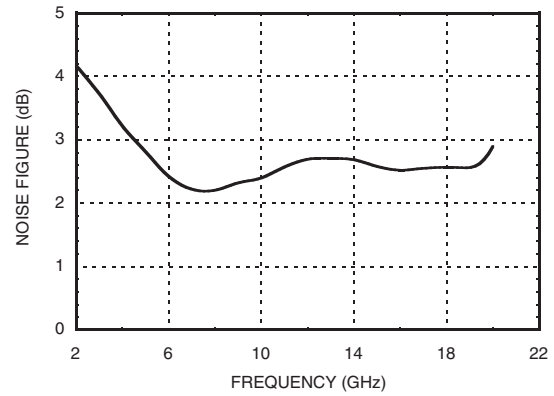

**Input Return Loss vs. Frequency**

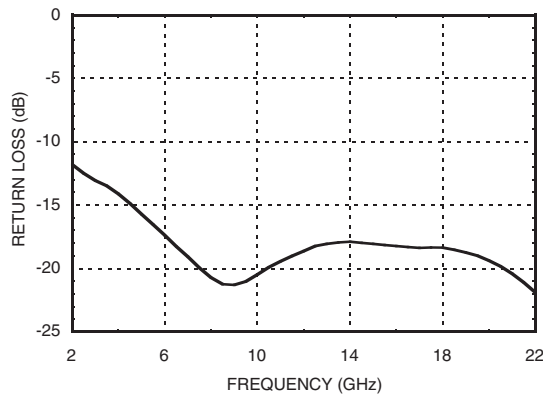

**Output Return Loss vs. Frequency**

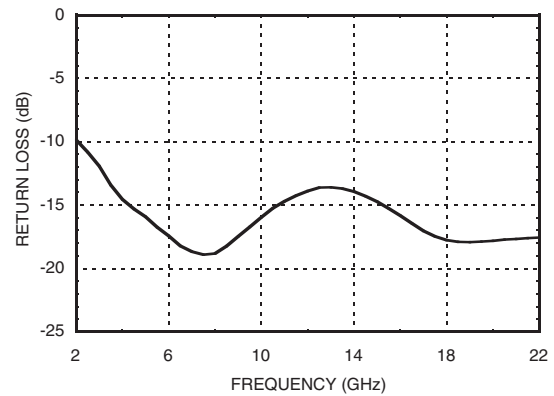

Note: Measured Performance Characteristics (Typical Performance at 25°C) Vd= 2.0 V, Id = 55 mA

## GaAs HEMT MMIC WIDEBAND LOW NOISE AMPLIFIER, 2 - 20 GHz

### Absolute Maximum Ratings

Drain Bias Voltage	+3.7 Vdc
Gate Bias Voltage	-1 to +0.3 Vdc
RF Input Power	5 dBm
Channel Temperature	180 °C



**ELECTROSTATIC SENSITIVE DEVICE  
OBSERVE HANDLING PRECAUTIONS**

### Outline Drawing

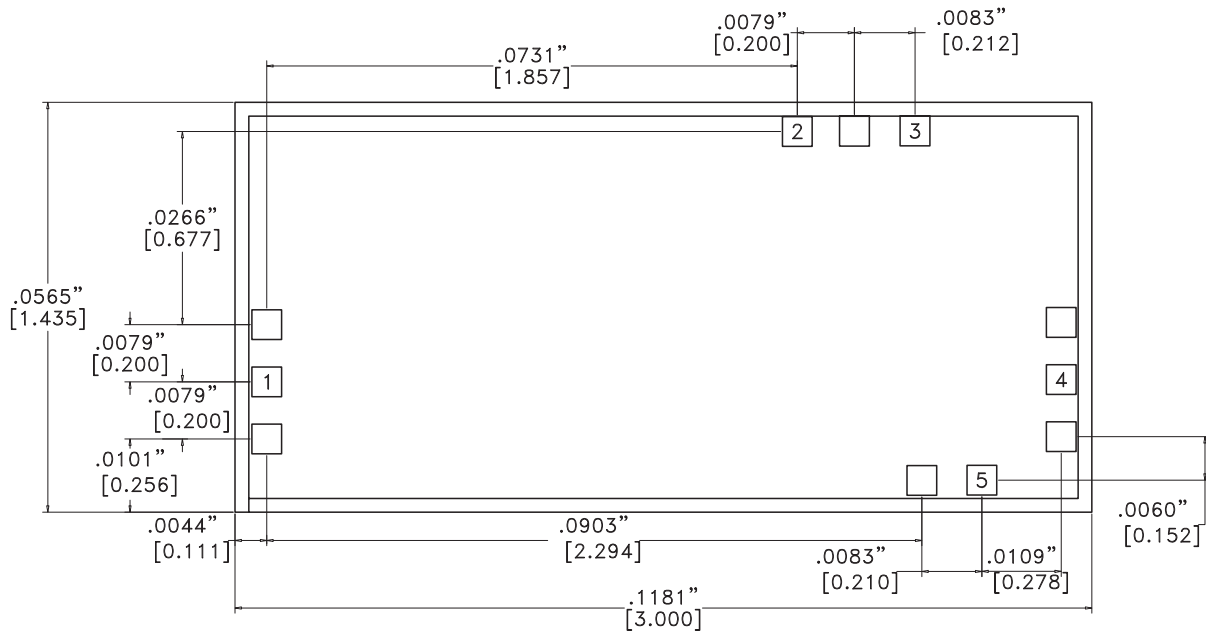

### Die Packaging Information [1]

Standard	Alternate
GP-2 (Gel Pack)	[2]

[1] Refer to the "Packaging Information" section for die packaging dimensions.



[2] For alternate packaging information contact Hittite Microwave Corporation.

#### NOTES:

1. ALL DIMENSIONS ARE IN INCHES [MM].
2. TYPICAL BOND PAD IS .004" SQUARE.
3. BACKSIDE METALLIZATION: GOLD.
4. BACKSIDE METAL IS GROUND.
5. BOND PAD METALLIZATION: GOLD.
6. CONNECTION NOT REQUIRED FOR UNLABELED BOND PADS.
7. OVERALL DIE SIZE ±.002"

## GaAs HEMT MMIC WIDEBAND LOW NOISE AMPLIFIER, 2 - 20 GHz

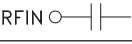
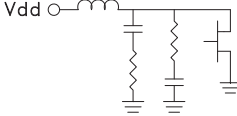
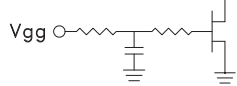
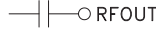
### Pad Descriptions

Pad Number	Function	Pad Description	Interface Schematic
1	RFIN	This pad is AC coupled and matched to 50 Ohms.	
2	Vdd	Power Supply Voltage for the amplifier. See Assembly Diagram for required external components.	
3, 5	Vgg	Gate control for amplifier. Please follow "MMIC Amplifier Biasing Procedure" application note. See assembly for required external components.	
4	RFOUT	This pad is AC coupled and matched to 50 Ohms.	
Die Bottom	GND	Die Bottom must be connected to RF/DC ground.	

## GaAs HEMT MMIC WIDEBAND LOW NOISE AMPLIFIER, 2 - 20 GHz

1

LOW NOISE AMPLIFIERS - CHIP

### Assembly Diagram

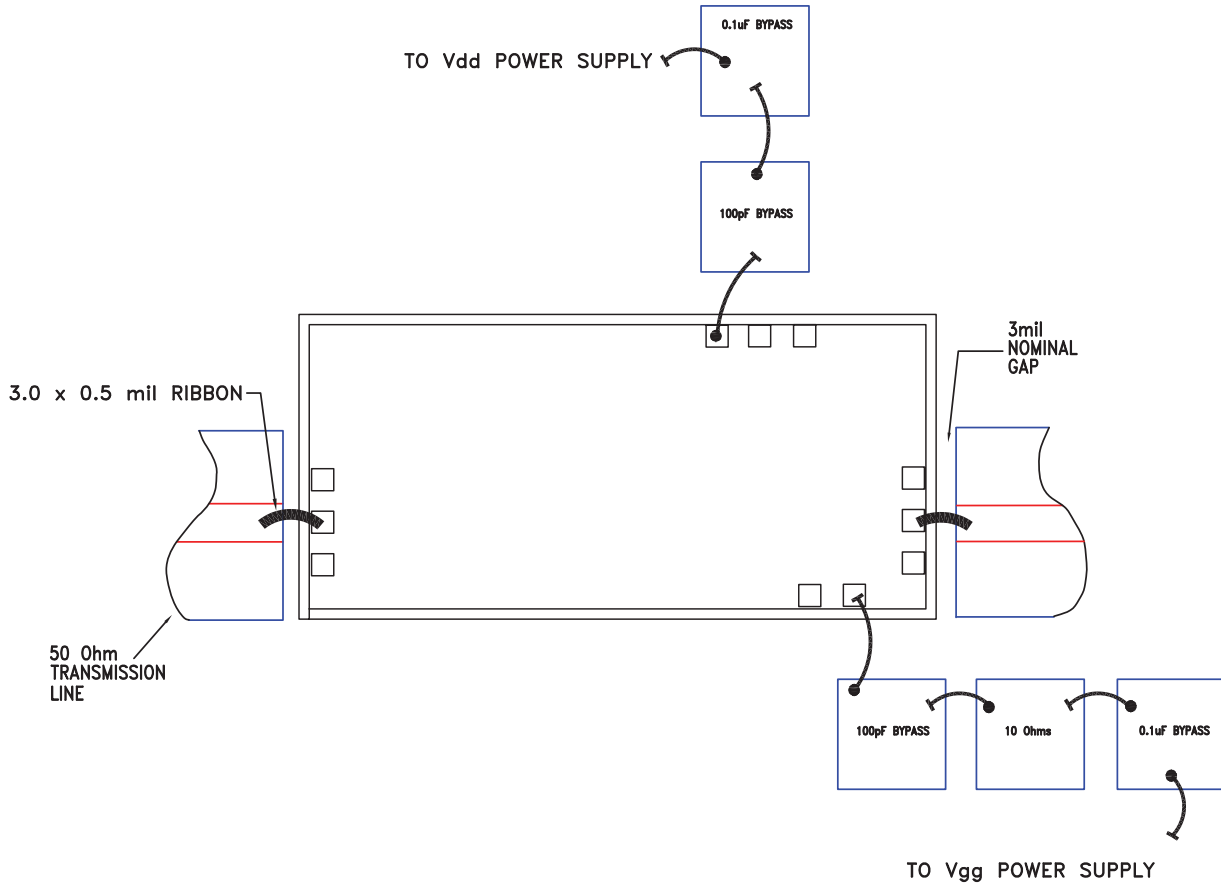

Note 1: Bypass caps should be 100 pF (approximately) ceramic (single-layer) placed no farther than 30 mils from the amplifier

Note 2: Best performance obtained from use of <10 mil (long) by 3 by 0.5 mil ribbons on input and output. 10 Ohms

Note 3: Gate bond pads (VG) exist on the upper & lower sides of the MMIC for assembly convenience. For best performance the unused pad should be attached to a 100pF cap to ground, but is not required.

**GaAs HEMT MMIC WIDEBAND  
LOW NOISE AMPLIFIER, 2 - 20 GHz**

**Mounting & Bonding Techniques for Millimeterwave GaAs MMICs**

The die should be attached directly to the ground plane eutectically or with conductive epoxy (see HMC general Handling, Mounting, Bonding Note).

50 Ohm Microstrip transmission lines on 0.127mm (5 mil) thick alumina thin film substrates are recommended for bringing RF to and from the chip (Figure 1). If 0.254mm (10 mil) thick alumina thin film substrates must be used, the die should be raised 0.150mm (6 mils) so that the surface of the die is coplanar with the surface of the substrate. One way to accomplish this is to attach the 0.102mm (4 mil) thick die to a 0.150mm (6 mil) thick molybdenum heat spreader (moly-tab) which is then attached to the ground plane (Figure 2).

Microstrip substrates should be brought as close to the die as possible in order to minimize bond wire length. Typical die-to-substrate spacing is 0.076mm (3 mils).

**Handling Precautions**

Follow these precautions to avoid permanent damage.

**Storage:** All bare die are placed in either Waffle or Gel based ESD protective containers, and then sealed in an ESD protective bag for shipment. Once the sealed ESD protective bag has been opened, all die should be stored in a dry nitrogen environment.

**Cleanliness:** Handle the chips in a clean environment. DO NOT attempt to clean the chip using liquid cleaning systems.

**Static Sensitivity:** Follow ESD precautions to protect against > ± 250V ESD strikes.

**Transients:** Suppress instrument and bias supply transients while bias is applied. Use shielded signal and bias cables to minimize inductive pick-up.

**General Handling:** Handle the chip along the edges with a vacuum collet or with a sharp pair of bent tweezers. The surface of the chip has fragile air bridges and should not be touched with vacuum collet, tweezers, or fingers.

**Mounting**

The chip is back-metallized and can be die mounted with AuSn eutectic preforms or with electrically conductive epoxy. The mounting surface should be clean and flat.

**Eutectic Die Attach:** A 80/20 gold tin preform is recommended with a work surface temperature of 255 °C and a tool temperature of 265 °C. When hot 90/10 nitrogen/hydrogen gas is applied, tool tip temperature should be 290 °C. DO NOT expose the chip to a temperature greater than 320 °C for more than 20 seconds. No more than 3 seconds of scrubbing should be required for attachment.

**Epoxy Die Attach:** Apply a minimum amount of epoxy to the mounting surface so that a thin epoxy fillet is observed around the perimeter of the chip once it is placed into position. Cure epoxy per the manufacturer's schedule.

**Wire Bonding**

Ball or wedge bond with 0.025 mm (1 mil) diameter pure gold wire is recommended. Thermosonic wirebonding with a nominal stage temperature of 150 °C and a ball bonding force of 40 to 50 grams or wedge bonding force of 18 to 22 grams is recommended. Use the minimum level of ultrasonic energy to achieve reliable wirebonds. Wirebonds should be started on the chip and terminated on the package or substrate. All bonds should be as short as possible <0.31 mm (12 mils).

