



GaAs MMIC x2 ACTIVE FREQUENCY MULTIPLIER MODULE, 24 - 33 GHz OUTPUT



4

FREQUENCY MULTIPLIERS

Typical Applications

The HMC-C033 is suitable for:

- Clock Generation Applications:
SONET OC-192 & SDH STM-64
- Point-to-Point & VSAT Radios
- Military EW/Radar
- Space

Functional Diagram

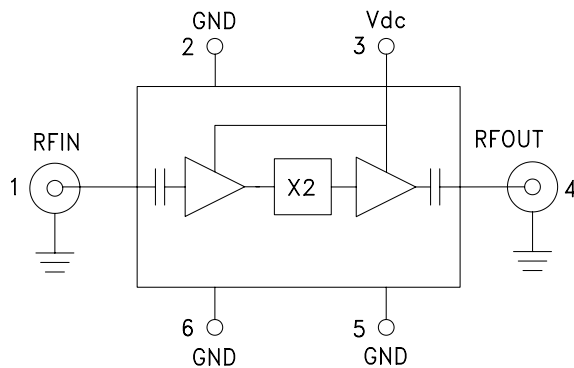

Features

- High Output Power: +17 dBm
- Low Input Power Drive: 0 to +6 dBm
- 100 KHz SSB Phase Noise: -132 dBc/Hz
- Single Supply: +5V @ 81 mA
- Hermetically Sealed Module
- Field Replaceable 2.92mm Connectors
- 55 °C to +85 °C Operating Temperature

General Description

The HMC-C033 is a x2 active broadband frequency multiplier utilizing GaAs PHEMT technology in a miniature hermetic module. When driven by a 3 dBm signal, the multiplier provides +17 dBm typical output power from 24 to 33 GHz. The F_o and $3F_o$ isolations are >20 dBc and >30 dBc respectively at 28 GHz with respect to output signal level. This frequency multiplier features DC blocked I/O's, and is ideal for use in LO multiplier chains for Pt to Pt & VSAT Radios yielding reduced parts count vs. traditional approaches. The low additive SSB Phase Noise of -132 dBc/Hz at 100 kHz offset helps maintain good system noise performance.

Electrical Specifications, $T_A = +25^\circ \text{C}$, $V_{dc} = +5\text{V}$, 3 dBm Drive Level

Parameter	Min.	Typ.	Max.	Units
Frequency Range, Input	12 - 16.5			GHz
Frequency Range, Output	24 - 33			GHz
Output Power	14	17		dBm
F_o Isolation (with respect to output level)		20		dBc
$3F_o$ Isolation (with respect to output level)		30		dBc
Input Return Loss		13		dB
Output Return Loss		20		dB
SSB Phase Noise (100 kHz Offset)		-132		dBc/Hz
Supply Current		81		mA



GaAs MMIC x2 ACTIVE FREQUENCY MULTIPLIER MODULE, 24 - 33 GHz OUTPUT

Output Power vs. Temperature @ 3 dBm Drive Level

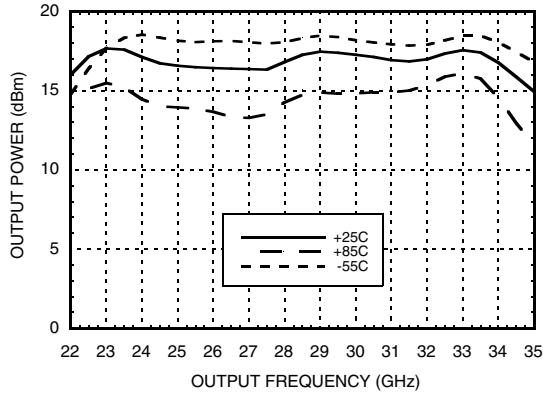

Output Power vs. Drive Level

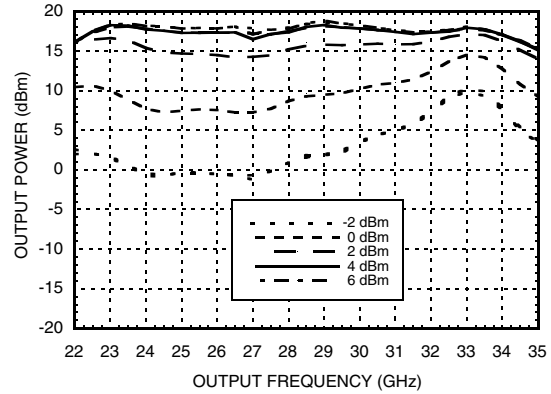

Output Power vs. Supply Voltage @ 3 dBm Drive Level

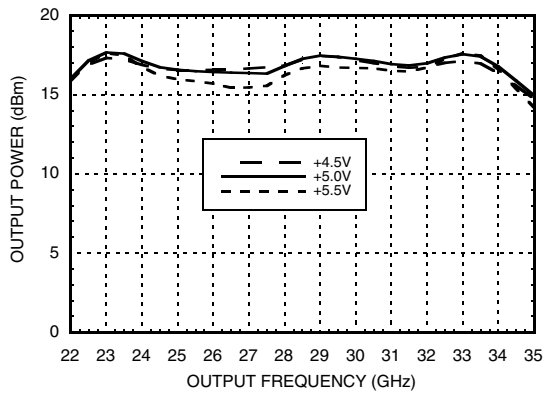

Isolation @ 3 dBm Drive Level

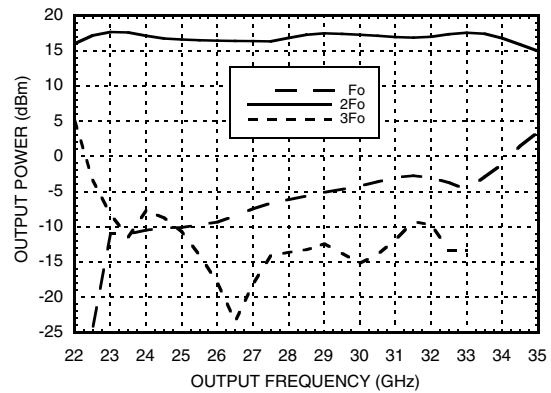

Output Power vs. Input Power

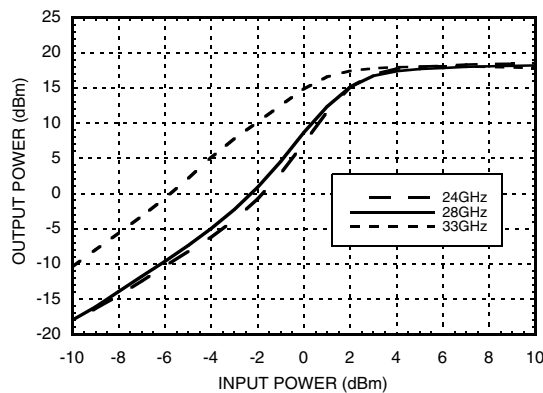



GaAs MMIC x2 ACTIVE FREQUENCY MULTIPLIER MODULE, 24 - 33 GHz OUTPUT

Input Return Loss vs. Temperature @ 0 dBm Drive Level

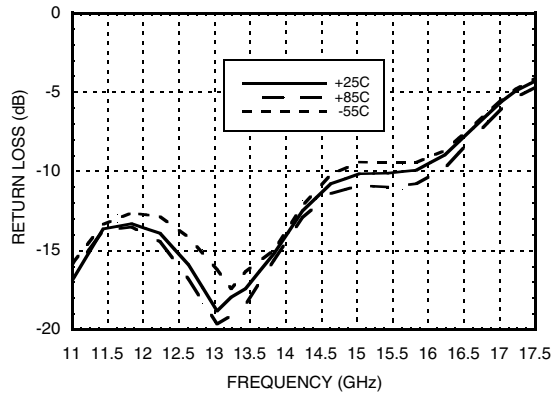

Output Return Loss vs. Temperature @ 0 dBm Drive Level

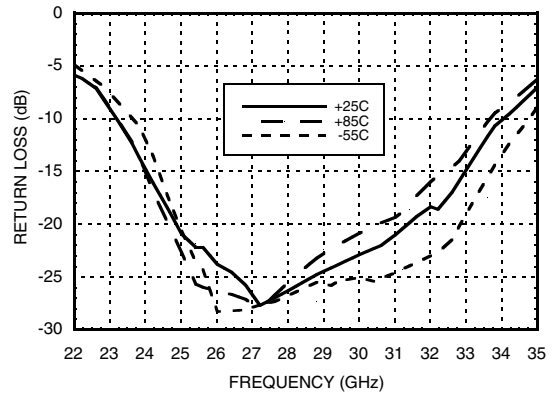

Absolute Maximum Ratings

RF Input (Vdc = +5V)	+13 dBm
Bias Supply Voltage (Vdc)	+6 Vdc
Storage Temperature	-65 to +150 °C
Operating Temperature	-55 to +85 °C

Typical Supply Current vs. Vdd

Vdd (Vdc)	Idd (mA)
4.5	81
5.0	81
5.5	81

Note:
Multiplier will operate over full voltage range shown above.



**ELECTROSTATIC SENSITIVE DEVICE
OBSERVE HANDLING PRECAUTIONS**

Pin Description

Pin Number	Function	Description	Interface Schematic
1	RFIN and RF Ground	Pin is AC coupled and matched to 50 Ohms. RFIN uses a female 2.92mm field replaceable connector.	
2, 5, 6	GND	One of these pins must be connected to power supply ground.	
3	Vdc	Power supply voltage for the amplifier includes a 7.5V zener diode for over voltage and negative voltage protection	
4	RFOUT and RF Ground	Pin is AC coupled and matched to 50 Ohms. RFOUT uses a female 2.92mm field replaceable connector.	



GaAs MMIC x2 ACTIVE FREQUENCY MULTIPLIER MODULE, 24 - 33 GHz OUTPUT

Outline Drawing

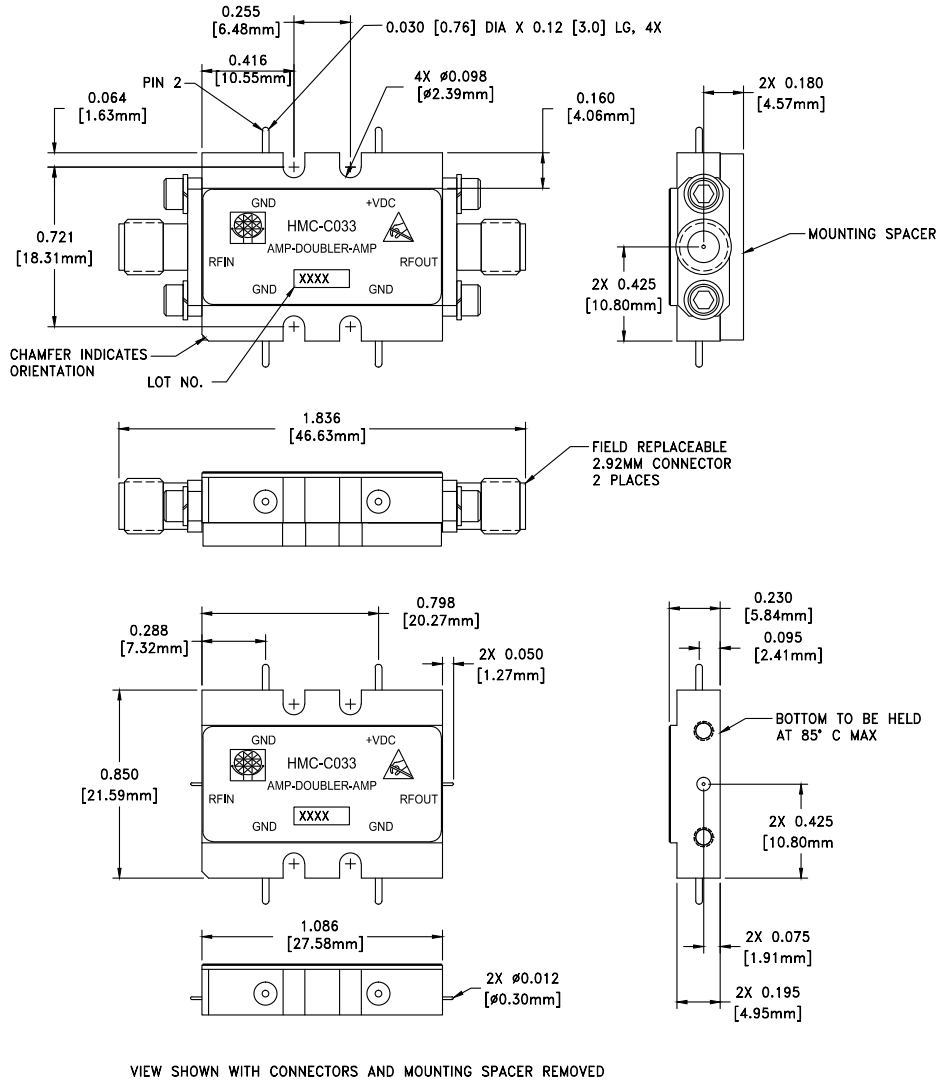

VIEW SHOWN WITH CONNECTORS AND MOUNTING SPACER REMOVED

Package Information

Package Type	C-10
Package Weight [1]	18.7 gms [2]
Spacer Weight	3.3 gms [2]

[1] Includes the connectors

[2] ±1 gms Tolerance

NOTES:

1. PACKAGE, LEADS, COVER MATERIAL: KOVAR™
2. FINISH: GOLD PLATE OVER NICKEL PLATE
3. ALL DIMENSIONS ARE IN INCHES [MILLIMETERS]
4. TOLERANCES:
 - 4.1 .XX = ±0.02
 - 4.2 .XXX = ±0.010
5. FIELD REPLACEABLE 2.92mm CONNECTORS TENSOLITE 231CCSF OR EQUIVALENT