

22.5° MMIC 4-BIT DIGITAL PHASE SHIFTER MODULE, 8 - 12 GHz



Features

- Low RMS Phase Error: 6°
- Low Insertion Loss: 7 dB
- Excellent Flatness
- 360° Coverage, LSB = 22.5°
- Hermetically Sealed Module
- Field Replaceable SMA Female Connectors

Typical Applications

The HMC-C055 is ideal for:

- EW Receivers
- Weather & Military Radar
- Satellite Communications
- Beamforming Modules

Functional Diagram

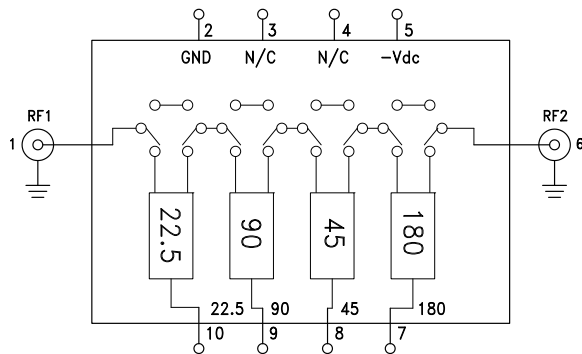

General Description

The HMC-C055 is a 4-bit digital phase shifter which is rated from 8 to 12 GHz, providing 0 to 360 degrees of monotonic phase coverage, with a LSB of 22.5 degrees. The HMC-C055 features a very low RMS phase error of 6 degrees and a low insertion loss variation of ± 1 dB across all phase states. This high accuracy phase shifter requires a single DC voltage of -5V and is internally matched to 50 Ohms. The package is a hermetically sealed module that can utilize field replaceable SMA connectors or be used as a drop-in module.

Electrical Specifications, $T_A = +25^\circ \text{C}$, 50 Ohm System, Control Voltage = 0/+5V, -Vdc = -5V

Parameter	Min.	Typ.	Max.	Units
Frequency Range	8		12	GHz
Insertion Loss*		7	8.5	dB
Input Return Loss*		10		dB
Output Return Loss*		8		dB
Phase Error*		± 10	± 17	deg
RMS Phase Error		6		deg
Gain Variation*		± 1		dB
Input Power for 1 dB Compression		24		dBm
Input Third Order Intercept		38		dBm
Control Voltage Current		2.5		mA

*Note: All States Shown

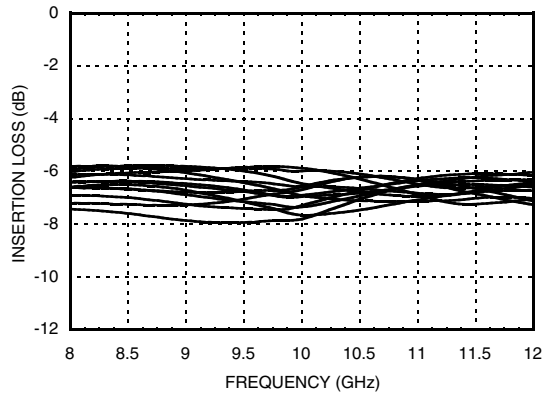
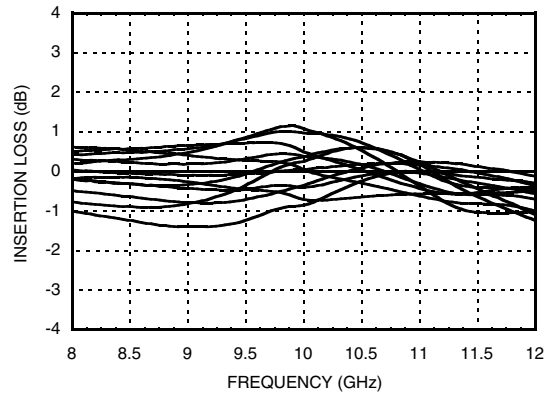
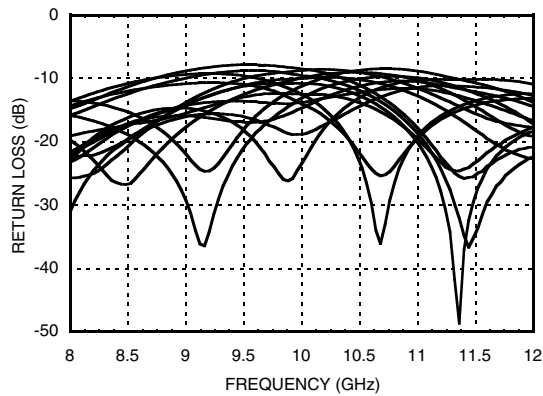
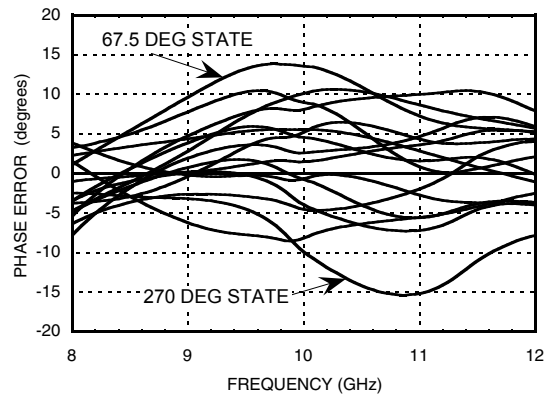
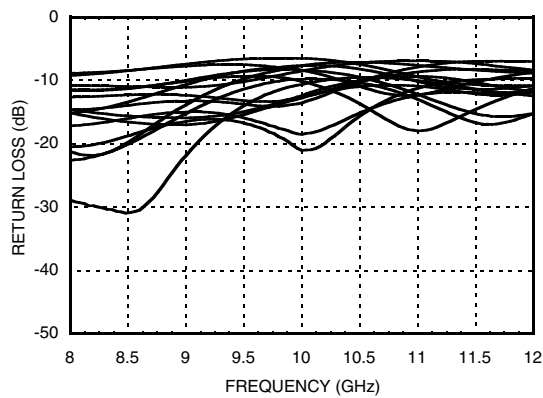
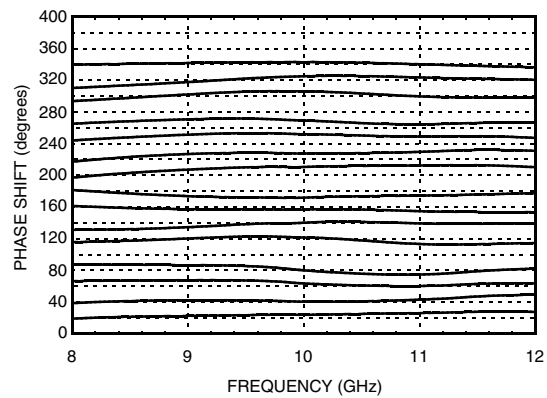

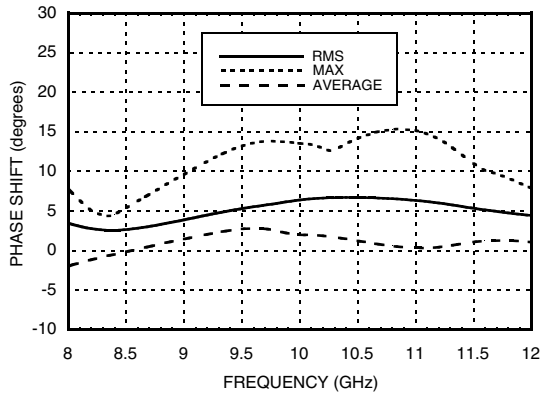
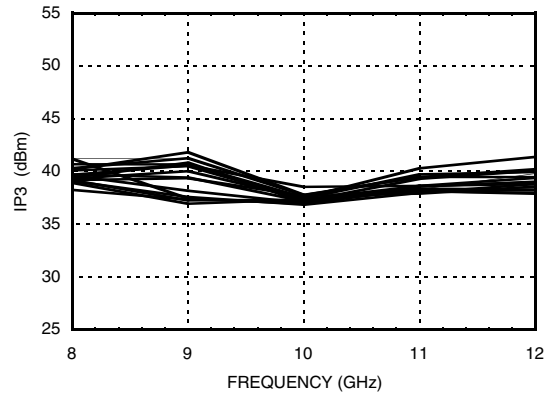
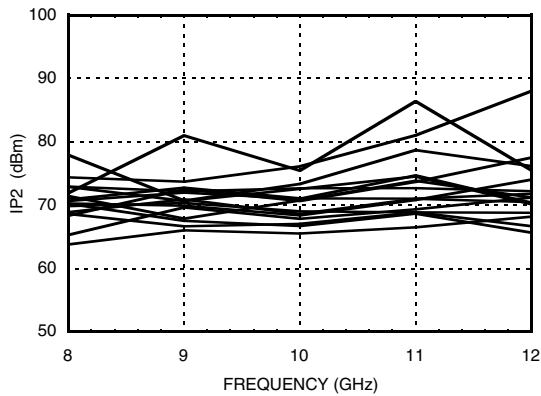
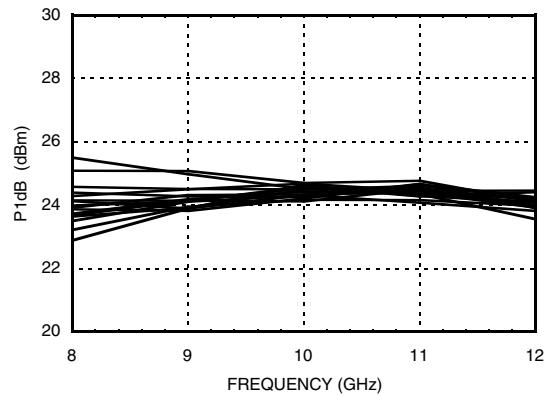
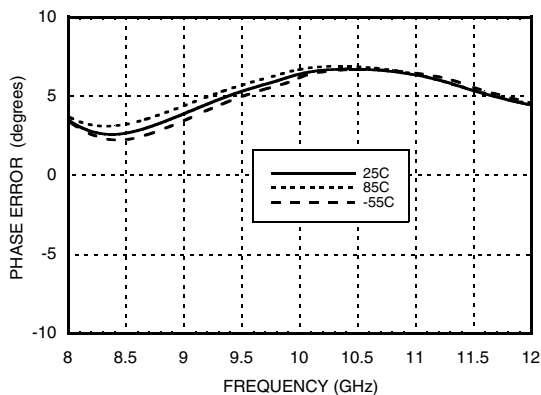
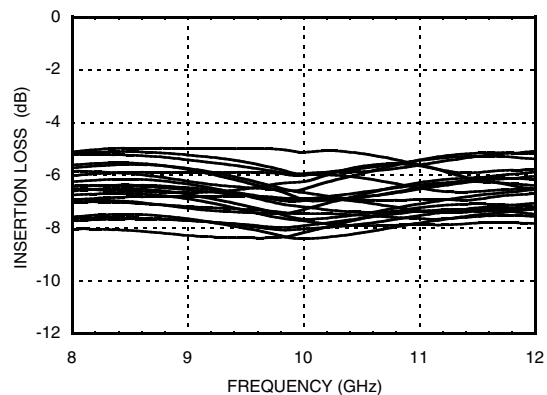
**22.5° MMIC 4-BIT DIGITAL
PHASE SHIFTER MODULE, 8 - 12 GHz**
Insertion Loss, All States

Normalized Loss, All States

Input Return Loss, All States

Phase Error, All States

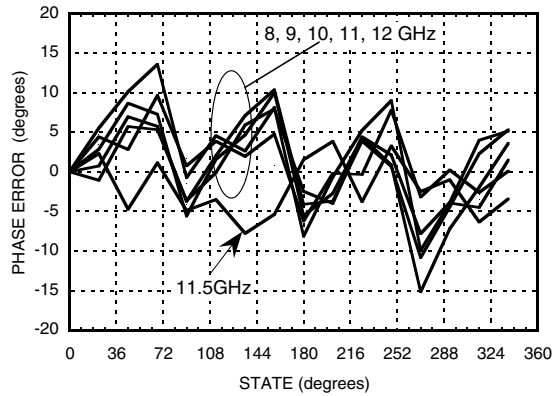
Output Return Loss, All States

Relative Phase Shift, All States



**22.5° MMIC 4-BIT DIGITAL
PHASE SHIFTER MODULE, 8 - 12 GHz**
**Relative Phase Shift,
RMS, Average, Max, All States**

Input IP3, All States

Input IP2, All States

Input P1dB, All States

RMS Phase Error vs. Temperature

Insertion Loss vs. Temperature All States



22.5° MMIC 4-BIT DIGITAL PHASE SHIFTER MODULE, 8 - 12 GHz

Phase Error vs. State



Absolute Maximum Ratings

Input Power (RF1, RF2) (8-12 GHz)	+27 dBm (T= +85 °C)
Channel Temperature (Tc)	150 °C
Supply Voltage (-Vdc)	-5.5V
Control Voltage	5.5V
Storage Temperature	-65 to +150 °C
Operating Temperature	-40 to +85 °C

Truth Table

Control Voltage Input				Phase Shift (Degree) RFIN - RFOUT
22.5	45	90	180	
0	0	0	0	Reference
1	0	0	0	22.5
0	1	0	0	45
0	0	1	0	90
0	0	0	1	180
1	1	1	1	337.5

Any combination of the above states will provide a phase shift approximately equal to the sum of the bits selected.

Control Voltage

State	Bias Condition
Low (0)	0V
High (1)	+5V



**ELECTROSTATIC SENSITIVE DEVICE
OBSERVE HANDLING PRECAUTIONS**



22.5° MMIC 4-BIT DIGITAL PHASE SHIFTER MODULE, 8 - 12 GHz

Outline Drawing

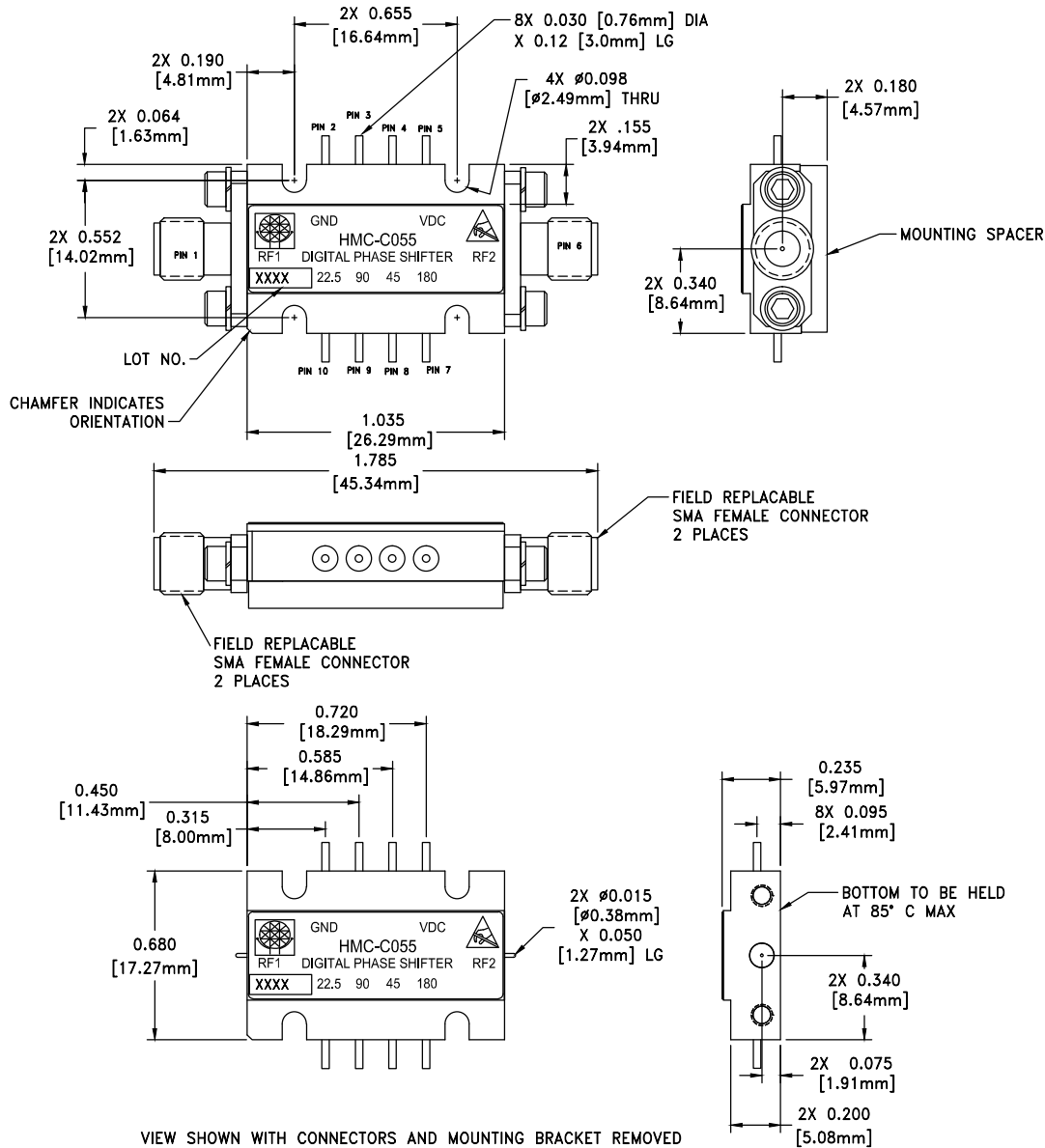

Package Information

Package Type	C-6
Package Weight [1]	17.4 gms [2]
Spacer Weight	3 gms [2]

[1] Includes the connectors

[2] \pm 1 gms Tolerance

NOTES:



1. PACKAGE, LEADS, COVER MATERIAL: KOVAR™
2. PLATING: ELECTROLYTIC GOLD 50 MICROINCHES MIN., OVER ELECTROLYTIC NICKEL 75 MICROINCHES MIN
3. MOUNTING SPACER: NICKEL PLATED ALUMINUM
4. ALL DIMENSIONS ARE IN INCHES [MILLIMETERS]
5. TOLERANCES \pm 0.010 [0.25] UNLESS OTHERWISE SPECIFIED
6. FIELD REPLACEABLE SMA CONNECTORS TENSOLITE 5602 - 5CCSF OR EQUIVALENT
7. TO MOUNT MODULE TO SYSTEM PLATFORM REPLACE 0 -80 HARDWARE WITH DESIRED MOUNTING SCREWS

For price, delivery, and to place orders, please contact Hittite Microwave Corporation:
 20 Alpha Road Chelmsford, MA 01824 Phone: 978-250-3343 Fax: 978-250-3373
 Order Online at www.hittite.com

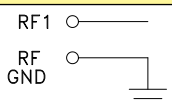

**22.5° MMIC 4-BIT DIGITAL
PHASE SHIFTER MODULE, 8 - 12 GHz**

Pin Descriptions

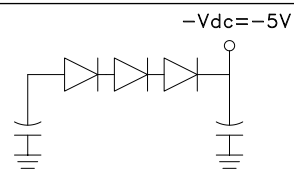
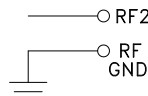
Pin Number	Function	Description	Interface Schematic
1	RF1 & RF Ground	RF input connector, coaxial female, field replaceable. This pin is AC coupled and matched to 50 Ohms.	
2	GND	This pin must be connected to RF/DC ground.	
3, 4	N/C	The pins are not connected internally; however, all data shown herein was measured with these pins connected to RF/DC ground externally.	
5	-Vdc	-5V DC Voltage	
6	RF2 & RF Ground	RF input connector, coaxial female, field replaceable. This pin is AC coupled and matched to 50 Ohms.	
7 - 10	180, 45, 90, 22.5	Control voltage input. See truth table and control voltage tables.	