

DATA SHEET

SKY18106-455LF: 0.4 – 2.2 GHz SP8T Antenna Switch With GSM Transmit Filters

Applications

- 2G GSM/EDGE
- 3G WCDMA

Features

- Wideband frequency range: 0.4 to 2.2 GHz
- Supports quad-band GSM/EDGE with up to six bands of WCDMA or LTE
- Low insertion loss:
 - 0.75 dB @ GSM, 1 GHz (includes transmit filter loss)
 - 0.90 dB @ GSM, 2 GHz (includes transmit filter loss)
 - 0.50 dB @ WCDMA transmit, 1 GHz
 - 0.75 dB @ WCDMA transmit, 2.1 GHz
- Good 2nd and 3rd harmonic performance: –45/–45 dBm @ +35 dBm and +33 dBm for low band and high band, respectively
- Over 20 dB GSM/EDGE harmonic attenuations
- Battery supply voltage: 2.65 to 6.00 V
- SPI logic ($V_{HIGH} = 1.8 V$)
- Small, QFN (26-pin, 3.0 x 3.8 mm) package (MSL1, 260 °C per JEDEC J-STD-020)



Skyworks Green™ products are compliant with all applicable legislation and are halogen-free. For additional information, refer to Skyworks Definition of Green™, document number SQ04-0074.

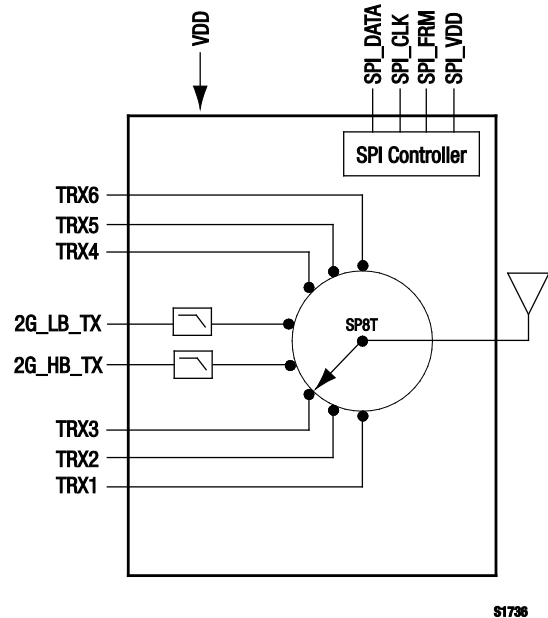

Figure 1. SKY18106-455LF Block Diagram

Description

The SKY18106-455LF is a single-pole, eight-throw (SP8T) Front-End Module (FEM) switch designed for multi-mode, high-power switching applications that demand low harmonics and low insertion loss. The switch is optimized for both 2G GSM/EDGE and 3G WCDMA applications. No external blocking capacitors are required on the RF ports.

The SKY18106-455LF consists of an SP8T switch, GSM transmit signal harmonic filters, and a Serial Peripheral Interface (SPI) controller. The low current consumption of the device makes it very suitable for battery-operated applications.

The switch is manufactured using a state of the art pHEMT process, and is provided in a compact 3.0 x 3.8 mm Quad Flat No-Lead (QFN) package.

A functional block diagram is shown in Figure 1. The pin configuration and package are shown in Figure 2. Signal pin assignments and functional pin descriptions are provided in Table 1.

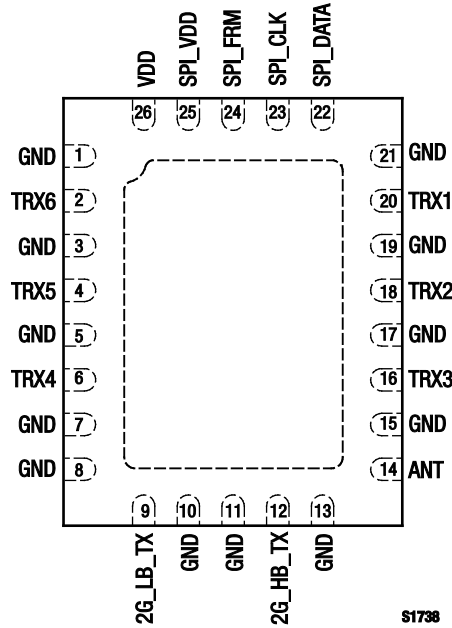

Figure 2. SKY18106-455LF Pinout – 26-Pin QFN (Top View)

Table 1. SKY18106-455LF Signal Descriptions (1 of 2)

Pin #	Name	Description	Pin #	Name	Description
1	GND	Ground	10	GND	Ground
2	TRX6	3G WCDMA transmit arm #6. This pin is either connected directly to or is disconnected from pin 14, depending on the control data applied to pin 22.	11	GND	Ground
3	GND	Ground	12	2G_HB_TX	High band GSM transmit. This pin is either connected directly to or is disconnected from pin 14, depending on the control data applied to pin 22.
4	TRX5	3G WCDMA transmit arm #5. This pin is either connected directly to or is disconnected from pin 14, depending on the control data applied to pin 22.	13	GND	Ground
5	GND	Ground	14	ANT	Antenna port. This pin is either connected directly to or is disconnected from pins 2, 4, 6, 9, 12, 16, 18, or 20, depending on the control data applied to pin 22.
6	TRX4	3G WCDMA transmit arm #4. This pin is either connected directly to or is disconnected from pin 14, depending on the control data applied to pin 22.	15	GND	Ground
7	GND	Ground	16	TRX3	3G WCDMA transmit arm #3. This pin is either connected directly to or is disconnected from pin 14, depending on the control data applied to pin 22.
8	GND	Ground	17	GND	Ground
9	2G_LB_TX	Low band GSM transmit. This pin is either connected directly to or is disconnected from pin 14, depending on the control data applied to pin 22.	18	TRX2	3G WCDMA transmit arm #2. This pin is either connected directly to or is disconnected from pin 14, depending on the control data applied to pin 22.

Table 1. SKY18106-455LF Signal Descriptions (2 of 2)

Pin #	Name	Description	Pin #	Name	Description
19	GND	Ground	23	SPI_CLK	SPI clock signal.
20	TRX1	3G WCDMA transmit arm #1. This pin is either connected directly to or is disconnected from pin 14, depending on the control data applied to pin 22.	24	SPI_FRM	SPI enable signal (slave select).
21	GND	Ground	25	SPI_VDD	SPI power supply for all slave devices (1.8 V nominal).
22	SPI_DATA	SPI data signal for read/write access.	26	VDD	Battery supply voltage input.

Table 2. SKY18106-455LF Absolute Maximum Ratings

Parameter	Symbol	Minimum	Typical	Maximum	Units
Supply voltage	V _{DD}			7	V
Input power	P _{IN}			+36	dBm
Storage temperature	T _{STG}	-50		+100	°C
Operating temperature	T _{OP}	-30		+85	°C

Note: Exposure to maximum rating conditions for extended periods may reduce device reliability. There is no damage to device with only one parameter set at the limit and all other parameters set at or below their nominal value. Exceeding any of the limits listed here may result in permanent damage to the device.

CAUTION: Although this device is designed to be as robust as possible, Electrostatic Discharge (ESD) can damage this device. This device must be protected at all times from ESD. Static charges may easily produce potentials of several kilovolts on the human body or equipment, which can discharge without detection. Industry-standard ESD precautions should be used at all times.

Electrical and Mechanical Specifications

The absolute maximum ratings of the SKY18106-455LF are provided in Table 2. Electrical specifications are provided in Table 3.

Table 4 provides the format of the 30-bit SPI_DATA signal. Table 5 describes the values assigned to the contents of the SPI_DATA signal.

The SKY18106-455LF can operate in one of 16 states as listed in Table 6. When VDD is high, the switch is active and its state is

controlled as described in Table 6. The switch may also be used in one of three modes: active, standby, and isolation. These modes are controlled by bits [15:11] of the SPI data word.

NOTE: The SPI_VDD signal (pin 25) must be pushed high for 2 ms before the first SPI command is sent to program the switch within the operating temperature range (T_{OP}).

Table 3. SKY18106-455LF Electrical Specifications (Note 1) (1 of 2)
(V_{DD} = 2.75 V, T_{OP} = +25 °C, SPI_VDD = 1.8 V, All Ports Terminated With a 50 Ω Load, Unless Otherwise Noted)

Parameter	Symbol	Test Condition	Min	Typical	Max	Units
Insertion loss, 2G		2G_TX_LB, 824 to 915 MHz		0.75	0.85	dB
		2G_TX_HB, 1710 to 1910 MHz		0.90	1.00	dB
Insertion loss, 2G		T _{OP} = +85 °C				
		2G_TX_LB, 824 to 915 MHz 2G_TX_HB, 1710 to 1910 MHz		0.85 1.00	0.95 1.10	dB dB
Insertion loss, TRX arms (Band 1)		1920 to 2170 MHz		0.75	0.85	dB
Insertion loss, TRX arms (Band 1)		T _{OP} = +85 °C 1920 to 2170 MHz		0.85	0.95	dB
Insertion loss, TRX arms (Bands 2 and 3)		1710 to 1990 MHz		0.7	0.8	dB
Insertion loss, TRX arms (Bands 2 and 3)		T _{OP} = +85 °C 1710 to 1990 MHz		0.8	0.9	dB
Insertion loss, TRX arms (Bands 5 and 8)		824 to 960 MHz		0.50	0.65	dB
Insertion loss, TRX arms (Bands 5 and 8)		T _{OP} = +85 °C 824 to 960 MHz		0.60	0.75	dB
Isolation		2G_TX_LB to ANT, 824 to 915 MHz	25	28		dB
		2G_TX_HB to ANT, 1710 to 1910 MHz	30	35		dB
		2G_TX_HB/2G_TX_LB to any TRX port	25	30		dB
Isolation, ANT to all "off" TRX ports		@ 2170 MHz	20	25		dB
Isolation, TRX to all "off" TRX ports		@ 2170 MHz	20	23		dB
Return loss		ANT port	15	20		dB
Harmonics	2fo and 3fo	2G_TX_LB to ANT, +35 dBm		-46	-42	dBm
		2G_TX_LB to ANT, +35 dBm, ANT VSWR = 4:1		-36	-33	dBm
		2G_TX_HB to ANT, +33 dBm		-46	-42	dBm
		2G_TX_HB to ANT, +33 dBm, ANT VSWR = 4:1		-36	-33	dBm
		3G TRX ports to ANT, +26 dBm		-55	-50	dBm
		3G TRX ports to ANT, +26 dBm, ANT VSWR = 4:1		-50	-45	dBm
3rd Order Intermodulation Distortion, all TRX ports to ANT port	IMD3	All blockers, all phase angles, transmit power = +15 dBm, blocker power = -20 dBm		-102	-97	dBm

Table 3. SKY18106-455LF Electrical Specifications (Note 1) (2 of 2)

(V_{DD} = 2.75 V, T_{OP} = +25 °C, SPI_VDD = 1.8 V, All Ports Terminated With a 50 Ω Load, Unless Otherwise Noted)

Parameter	Symbol	Test Condition	Min	Typical	Max	Units
Harmonics attenuation (low band)	2fo	2 nd harmonics attenuation, 2G_TX_LB to ANT	22			dB
	3fo	3 rd harmonics attenuation, 2G_TX_LB to ANT	24			dB
	4fo	4 th harmonics attenuation, 2G_TX_LB to ANT	16			dB
Harmonics attenuation (high band)	2fo	2 nd harmonics attenuation, 2G_TX_HB to ANT	24			dB
	3fo	3 rd harmonics attenuation, 2G_TX_HB to ANT	22			dB
	4fo	4 th harmonics attenuation, 2G_TX_HB to ANT	16			dB
Switching speed		Path to path			2	μs
		Standby to any “on” path			6	μs
Supply voltage	V _{DD}		2.65	2.75	6.00	V
Supply current: active mode standby mode	I _{DD}			500	800	μA
				3		μA
Control voltage		SPI V _{DD} high	1.6	1.8	2.0	V
		SPI V _{DD} low	-0.3	0	+0.3	V
		SPI control input voltage high	SPI VDD x 70%	1.8	SPI VDD + 0.3	V
		SPI control input voltage low		0	SPI VDD x 30%	V
Voltage Standing Wave Ratio, all ports	VSWR			1:2	1:5	–
Inband ripple, all ports					0.2	dB

Note 1: Performance is guaranteed only under the conditions listed in this Table.

Table 4. Data Bit Format (SPI_DATA Signal)

29	28	27	26	25	24	23	22	21	20	19	18	17	16
A13	A12	A11	A10	A9	A8	A7	A6	A5	A4	A3	A2	A1	A0
R/W	Address (Slave Type)			Address (Slave Identifier)				Address (Slave SPI Register)					

15	14	13	12	11	10	9	8	7	6	5	4	3	2	1	0
D15	D14	D13	D12	D11	D10	D9	D8	D7	D6	D5	D4	D3	D2	D1	D0
Data Bits															

Table 5. Data Bit Descriptions (SPI_DATA Signal)

Bit #	Bit ID	Function	Value (Binary)	Description
29	A13	Read/write mode	0 or 1	"1" = read, "0" = write
28	A12	Address (Slave Type)	0	001 used for the SKY18106-455LF
27	A11		0	
26	A10		1	
25	A9	Address (Slave Identifier)	0	Non-volatile value programmed by vendor
24	A8		0	
23	A7		0	
22	A6		1	
21	A5		0	
20	A4	Address (Slave SPI Register)	0	Not used
19	A3		0	
18	A2		0	
17	A1		0	
16	A0		0	
15	D15	Active mode on or off	1 or 0	See Table 6
14	D14	Data bit select 4 (MSB)	–	
13	D13	Data bit select 3	–	
12	D12	Data bit select 2	–	
11	D11	Data bit select 1 (LSB)	–	Reserved
10	D10	Not used	–	
9	D9		–	
8	D8		–	
7	D7		–	
6	D6		–	
5	D5		–	
4	D4		–	
3	D3		–	
2	D2		–	
1	D1		–	
0	D0	–		

Table 6. SKY18106-455LF Truth Table (SPI_DATA, Bits [15:11])

State	Band	Active Mode Bias	SPI Data Word			
		Bit[15]	Bit[14]	Bit[13]	Bit[12]	Bit[11]
1	Switch disabled (low current mode/standby mode)	0	0	0	0	0
2	GSM high band	1	0	0	0	1
3	GSM low band	1	0	0	1	0
4	Reserved	1	0	0	1	1
5	TRX1	1	0	1	0	0
6	TRX2	1	0	1	0	1
7	TRX3	1	0	1	1	0
8	Reserved	1	0	1	1	1
9	TRX4	1	1	0	0	0
10	TRX5	1	1	0	0	1
11	TRX6	1	1	0	1	0
12	Reserved	1	1	0	1	1
13	Reserved	1	1	1	0	0
14	Reserved	1	1	1	0	1
15	Reserved	1	1	1	1	0
16	Isolation state	1	1	1	1	1

Evaluation Board

The SKY18106-455LF Evaluation Board is used to test the performance of the SKY18106-455LF Antenna Switch. An Evaluation Board schematic diagram is provided in Figure 3. An assembly drawing for the Evaluation Board is shown in Figure 4.

Package Dimensions

The PCB layout footprint for the SKY18106-455LF is provided in Figure 5. Typical case markings are shown in Figure 6. Package dimensions for the 26-pin QFN are shown in Figure 7, and tape and reel dimensions are provided in Figure 8.

Package and Handling Information

Instructions on the shipping container label regarding exposure to moisture after the container seal is broken must be followed. Otherwise, problems related to moisture absorption may occur when the part is subjected to high temperature during solder assembly.

THE SKY18106-455LF is rated to Moisture Sensitivity Level 1 (MSL1) at 260 °C. It can be used for lead or lead-free soldering. For additional information, refer to the Skyworks Application Note, *Solder Reflow Information*, document number 200164.

Care must be taken when attaching this product, whether it is done manually or in a production solder reflow environment. Production quantities of this product are shipped in a standard tape and reel format.

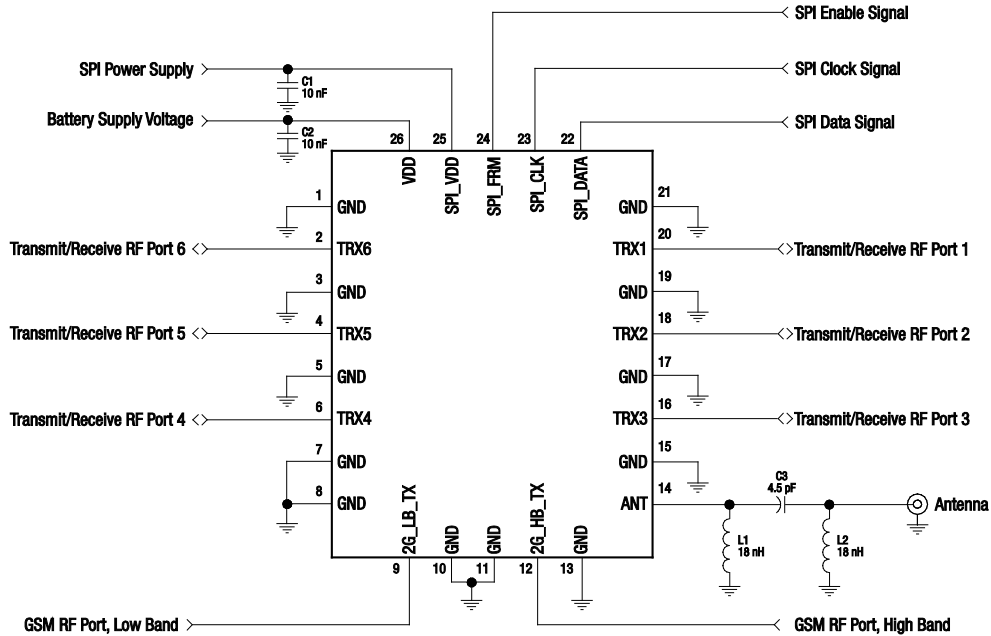

Notes: Components L1, L2, and C3 are recommended for ESD protection.

No DC blocking capacitors are needed on the RF ports.

S1978

Figure 3. SKY18106-455LF Evaluation Board Schematic

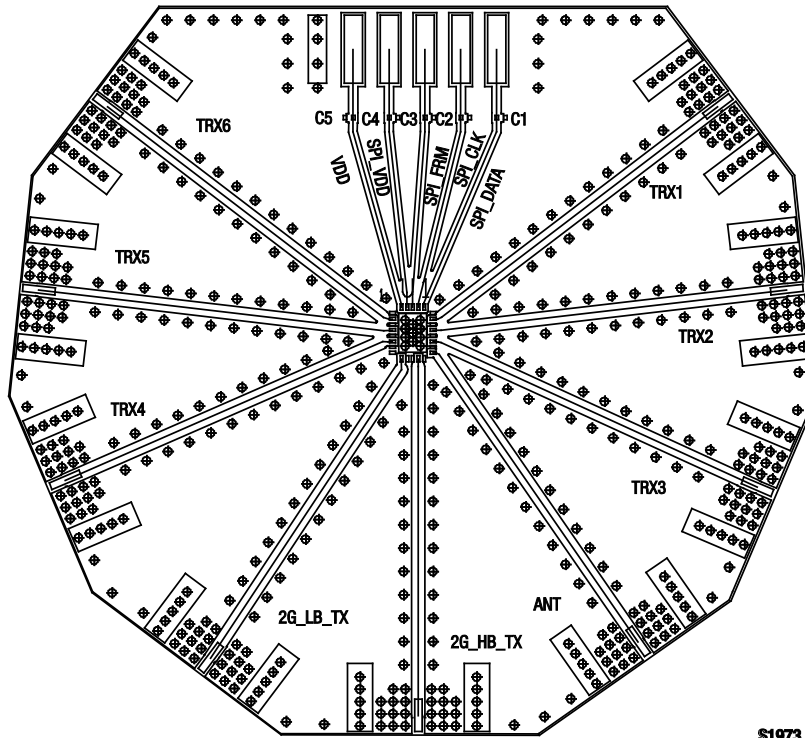

S1973

Figure 4. SKY18106-455LF Evaluation Board Assembly Drawing

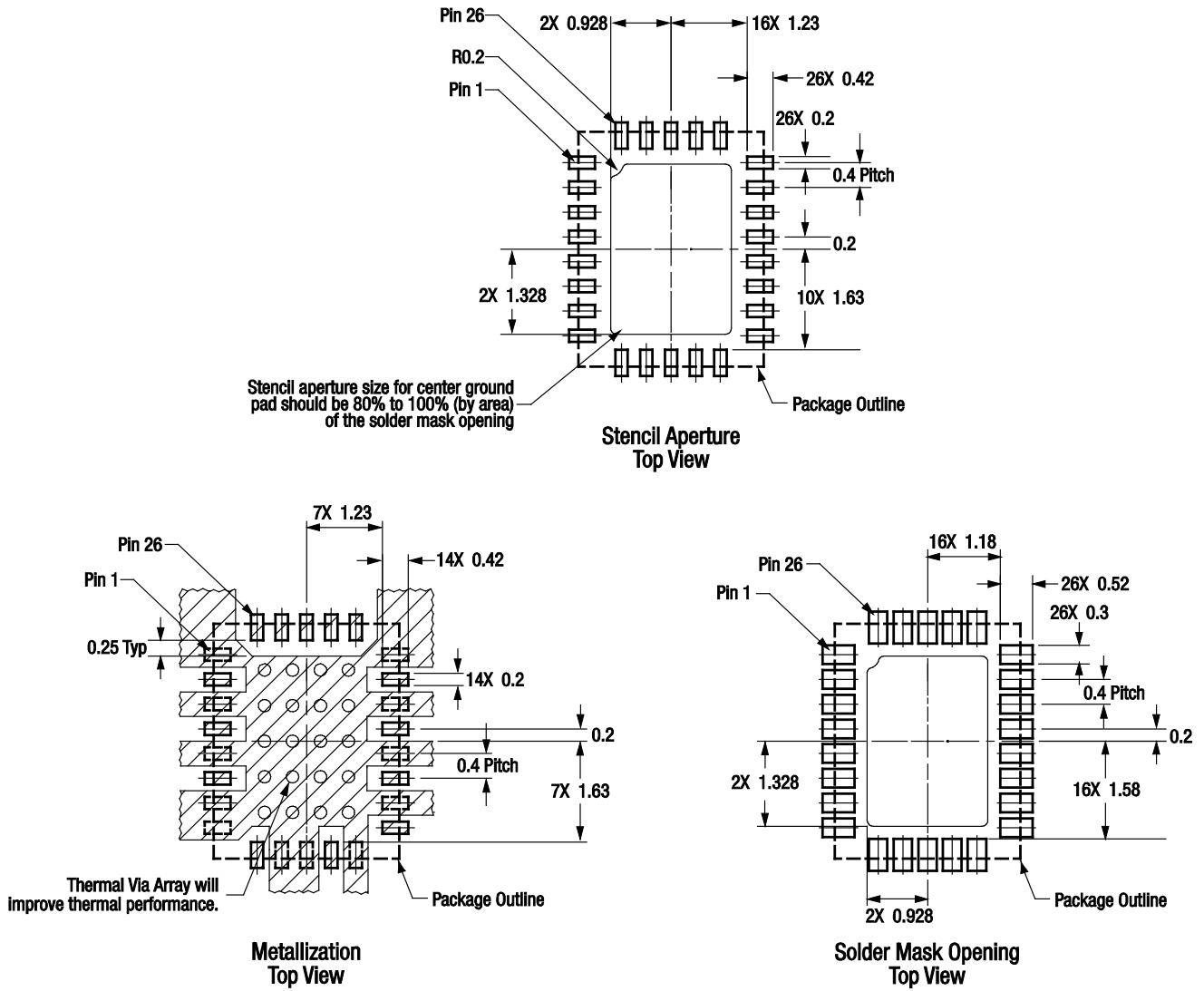

All measurements are in millimeters

S1984

Figure 5. SKY18106-455LF PCB Layout Footprint (Top View)

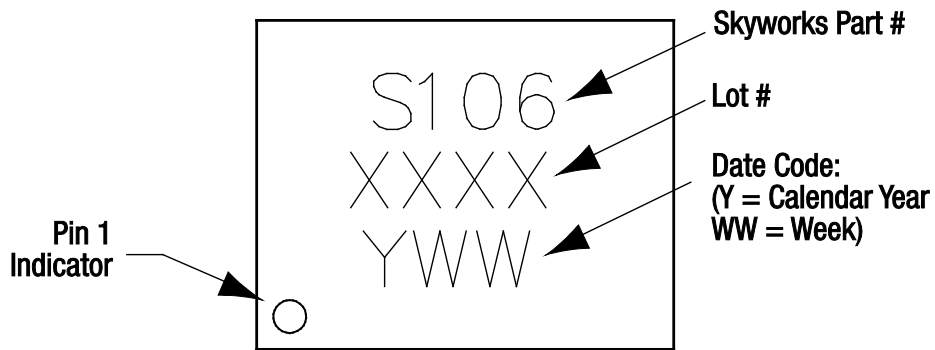
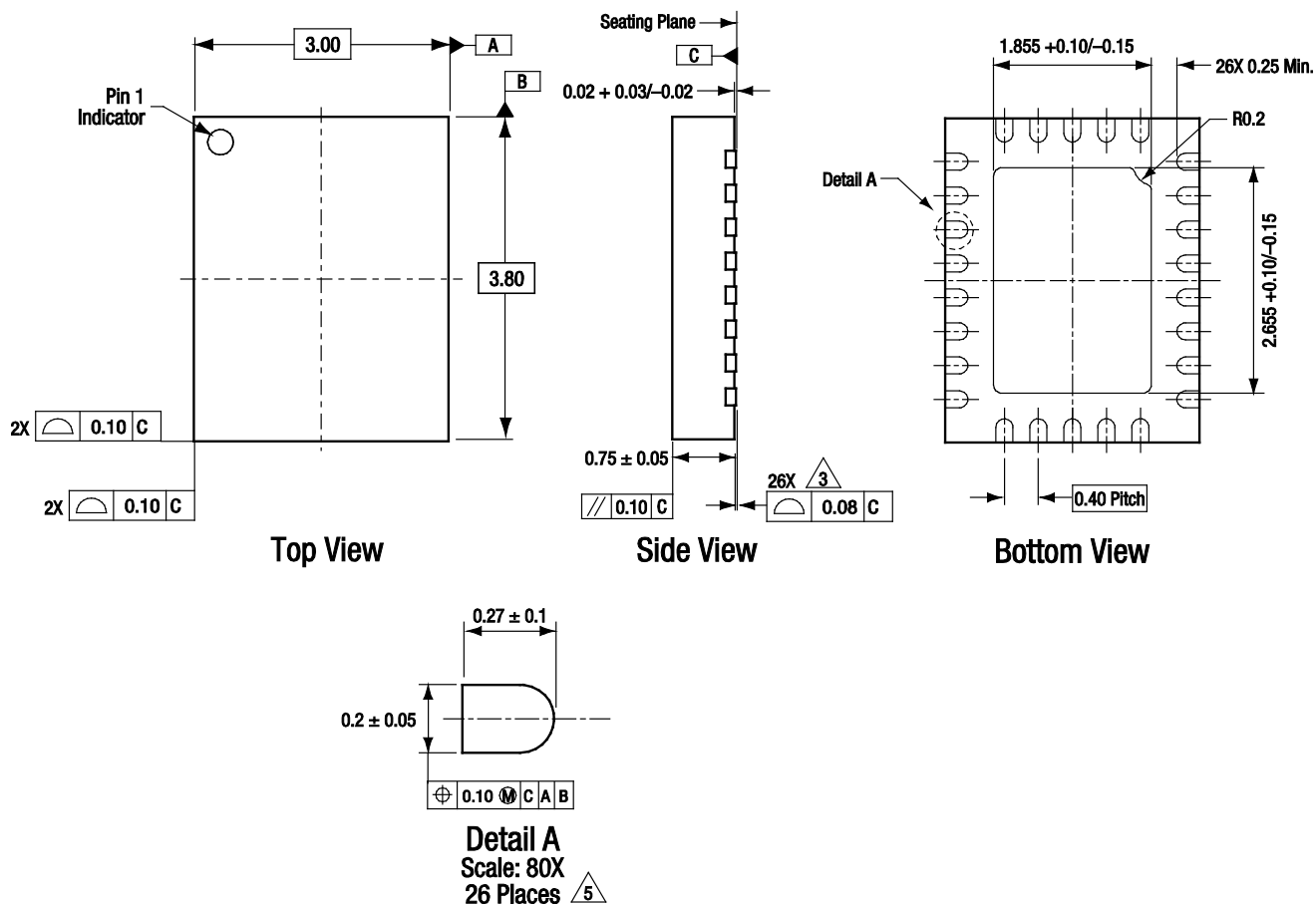

Figure 6. Typical Case Markings (Top View)



All measurements are in millimeters.
 Dimensioning and tolerancing according to ASME Y14.5M-1994.
 Coplanarity applies to the terminals and all other bottom surface metalization.
 Dimension applies to metalized terminal and is measured between 0.15 mm and 0.30 mm from terminal tip.

S2413

Figure 7. SKY18106-455LF 26-Pin QFN Package Dimensions

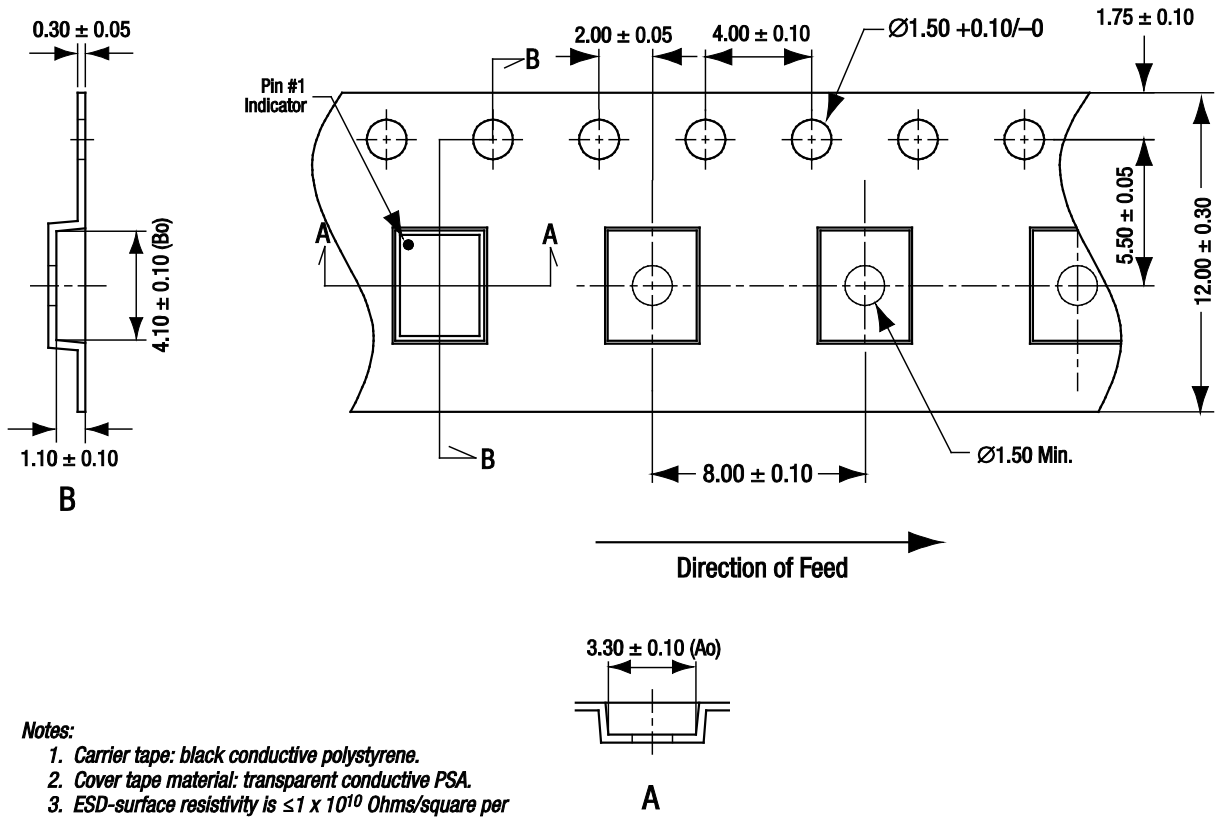

Notes:

1. Carrier tape: black conductive polystyrene.
2. Cover tape material: transparent conductive PSA.
3. ESD-surface resistivity is $\leq 1 \times 10^{10}$ Ohms/square per EIA, JEDEC TNR Specification.
4. Ten sprocket hole pitch cumulative tolerance: ± 0.20 mm.
5. Ao and Bo measured on plane 0.30 mm above the bottom of the pocket.
6. All measurements are in millimeters.

S2141

Figure 8. SKY18106-455LF Tape and Reel Dimensions

Ordering Information

Model Name	Manufacturing Part Number	Evaluation Board Part Number
SKY18106-455LF SP8T Antenna Switch	SKY18106-455LF	EN31-D655-001_V1

Copyright © 2010, 2011, 2012 Skyworks Solutions, Inc. All Rights Reserved.

Information in this document is provided in connection with Skyworks Solutions, Inc. (“Skyworks”) products or services. These materials, including the information contained herein, are provided by Skyworks as a service to its customers and may be used for informational purposes only by the customer. Skyworks assumes no responsibility for errors or omissions in these materials or the information contained herein. Skyworks may change its documentation, products, services, specifications or product descriptions at any time, without notice. Skyworks makes no commitment to update the materials or information and shall have no responsibility whatsoever for conflicts, incompatibilities, or other difficulties arising from any future changes.

No license, whether express, implied, by estoppel or otherwise, is granted to any intellectual property rights by this document. Skyworks assumes no liability for any materials, products or information provided hereunder, including the sale, distribution, reproduction or use of Skyworks products, information or materials, except as may be provided in Skyworks Terms and Conditions of Sale.

THE MATERIALS, PRODUCTS AND INFORMATION ARE PROVIDED “AS IS” WITHOUT WARRANTY OF ANY KIND, WHETHER EXPRESS, IMPLIED, STATUTORY, OR OTHERWISE, INCLUDING FITNESS FOR A PARTICULAR PURPOSE OR USE, MERCHANTABILITY, PERFORMANCE, QUALITY OR NON-INFRINGEMENT OF ANY INTELLECTUAL PROPERTY RIGHT; ALL SUCH WARRANTIES ARE HEREBY EXPRESSLY DISCLAIMED. SKYWORKS DOES NOT WARRANT THE ACCURACY OR COMPLETENESS OF THE INFORMATION, TEXT, GRAPHICS OR OTHER ITEMS CONTAINED WITHIN THESE MATERIALS. SKYWORKS SHALL NOT BE LIABLE FOR ANY DAMAGES, INCLUDING BUT NOT LIMITED TO ANY SPECIAL, INDIRECT, INCIDENTAL, STATUTORY, OR CONSEQUENTIAL DAMAGES, INCLUDING WITHOUT LIMITATION, LOST REVENUES OR LOST PROFITS THAT MAY RESULT FROM THE USE OF THE MATERIALS OR INFORMATION, WHETHER OR NOT THE RECIPIENT OF MATERIALS HAS BEEN ADVISED OF THE POSSIBILITY OF SUCH DAMAGE.

Skyworks products are not intended for use in medical, lifesaving or life-sustaining applications, or other equipment in which the failure of the Skyworks products could lead to personal injury, death, physical or environmental damage. Skyworks customers using or selling Skyworks products for use in such applications do so at their own risk and agree to fully indemnify Skyworks for any damages resulting from such improper use or sale.

Customers are responsible for their products and applications using Skyworks products, which may deviate from published specifications as a result of design defects, errors, or operation of products outside of published parameters or design specifications. Customers should include design and operating safeguards to minimize these and other risks. Skyworks assumes no liability for applications assistance, customer product design, or damage to any equipment resulting from the use of Skyworks products outside of stated published specifications or parameters.

Skyworks, the Skyworks symbol, and “Breakthrough Simplicity” are trademarks or registered trademarks of Skyworks Solutions, Inc., in the United States and other countries. Third-party brands and names are for identification purposes only, and are the property of their respective owners. Additional information, including relevant terms and conditions, posted at www.skyworksinc.com, are incorporated by reference.