

Current Mode Control PWM Regulator IC For Switching Power Supplies

Features and Benefits

- Small DIP8 package with 10 to 15 W power output 230 VAC
- Current Mode PWM control with 100 kHz switching frequency
- Built-in Random Switching function, reducing EMI noise, and simplifying EMI filters, and therefore reducing cost
- Built-in Slope Compensation function, avoiding subharmonic oscillation
- Built-in Auto Standby function (Input Power, $P_{IN} < 25$ mW at no load)
 - Normal operation: PWM mode
 - Light load operation: Standby mode (burst oscillation)
- Built-in Audible Noise Suppression function during Standby mode
- Built-in Startup Circuit, reducing power consumption in standby operation, and eliminating external components.
- Bias-Assist function, improving startup operation, suppressing V_{CC} voltage drop in operation, and allowing use of smaller V_{CC} capacitor

Continued on the next page...

Package: 8-pin DIP



Not to scale

Description

The STR-A60xxH series are power ICs for switching power supplies, incorporating a power MOSFET and a current mode PWM controller IC. Including a startup circuit and a standby function in the controller, the product achieves low power consumption, low standby power, and high cost-effectiveness power supply systems with few external components.

The STR-A60xxH internal MOSFET has a V_{DSS} of 650 V(min) or 700 V(min), and an $R_{DS(on)}$ of 2.8 Ω or 6.0 Ω with a frequency of 100 kHz. Power output is rated at 10 or 15 W at 230 VAC input and 8 or 13 W at wide input range (85 to 265 VAC).

The device is provided in an industry-standard DIP-8 package, with pin 6 removed for increased isolation.

Applications:

For switching power supplies used in:

- Battery chargers for cell phones, digital cameras, video cameras, shavers, emergency lights
- Stand-by power for LCD TVs, desktop PCs, LB Printers, audio equipment
- Small switched-mode power supplies for inkjet printers, DVD/CD players, set-top boxes
- Auxiliary power supplies for A/C, refrigerators, washers, dish washers, and other white goods

Typical Application

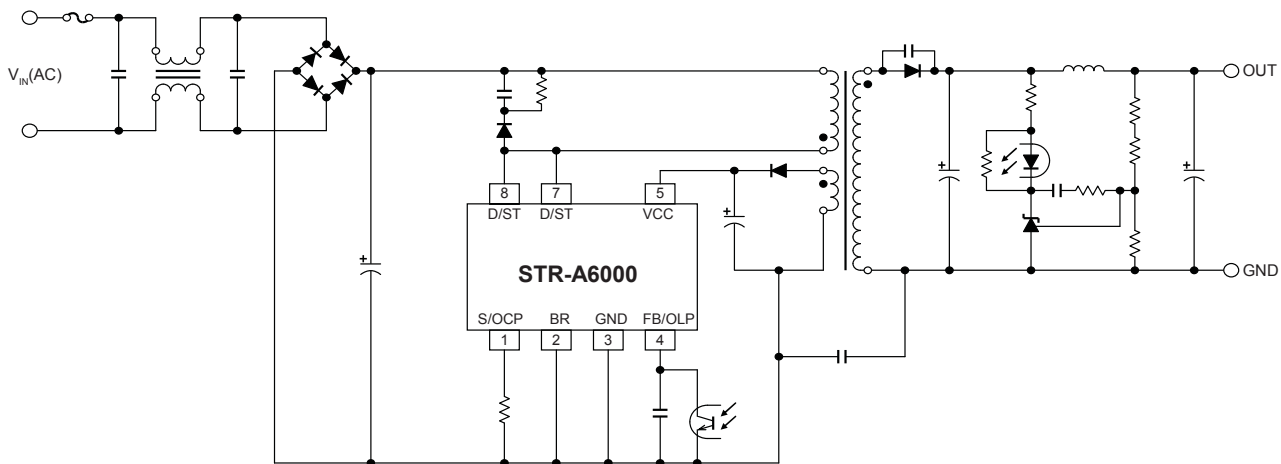

Features and Benefits (continued)

- Built-in Leading Edge Blanking function
- Built-in High Speed Latch Release function, releasing the latch shutdown immediately at turning off AC supply
- Two-chip structure, with a controller and a power MOSFET with guaranteed avalanche energy available to simplify surge absorber circuits
- Protection functions:
 - Brown-In and Brown-Out Protection function: auto-restart, prevention of excess input current and heat rise at low input voltage
 - Overcurrent Protection function (OCP): pulse-by-pulse built-in compensation circuit to minimize OCP point variation on AC input voltage
 - Overload Protection function (OLP): auto-restart, built-in timer, reduces heat during overload condition, and no external components required
 - Overvoltage Protection function (OVP): latched shutdown
 - Thermal Shutdown Protection function (TSD): shutdown latches device off to prevent continuous oscillation

Selection Guide

Part Number	f _{osc} (kHz)	MOSFET V _{DSS(min)} (V)	R _{DS(on)} (max) (Ω)	P _{OUT} * (W)		Package	Packing
				230 V	Wide		
STR-A6059H	100	650	6.0	10	8	DIP8 with pin 6 removed	50 pieces per tube
STR-A6062H		700	2.8	15	13		
STR-A6069H			6.0	10	8		

* The listed output power is based on the package thermal ratings, and the peak output power can be 120% to 140% of the value stated here. At low output voltage and short duty cycle, the output power may be less than the value stated here.

Absolute Maximum Ratings¹ Valid at $T_A = 25^\circ\text{C}$, unless otherwise specified

Characteristic	Symbol	Notes	Terminals	Rating	Unit	
Drain Current ²	I_{Dpeak}	Single pulse	STR-A6059H	8 – 1	1.8	A
			STR-A6062H	8 – 1	3.0	A
			STR-A6069H	8 – 1	1.8	A
Single Pulse Avalanche Energy ³	E_{AS}	Single pulse, $V_{DD} = 99\text{ V}$, $L = 20\text{ mH}$	STR-A6059H	8 – 1	24	mJ
			STR-A6062H	8 – 1	56	mJ
			STR-A6069H	8 – 1	24	mJ
	I_{Lpeak}	Single pulse, $V_{DD} = 99\text{ V}$, $L = 20\text{ mH}$	STR-A6059H	8 – 1	1.8	A
			STR-A6062H	8 – 1	2.2	A
			STR-A6069H	8 – 1	1.8	A
S/OCP Terminal Voltage	V_{OCP}		1 – 3	-2 to 6	V	
Controller IC (MIC) Supply Input Voltage	V_{CC}		5 – 3	32	V	
FB/OLP Terminal Voltage	V_{FB}		4 – 3	-0.3 to 14	V	
FB/OLP Terminal Sink Current	I_{FB}		4 – 3	1.0	mA	
BR Terminal Voltage	V_{BR}		2 – 3	-0.3 to 7	V	
BR Terminal Sink Current	I_{BR}		2 – 3	1.0	mA	
MOSFET Power Dissipation ⁴	P_{D1}	Mounted on a 15 mm × 15 mm PCB	8 – 1	1.35	W	
Controller IC (MIC) Power Dissipation	P_{D2}		5 – 3	1.2	W	
Operating Ambient Temperature	T_{OP}	Maximum recommended internal leadframe temperature, $T_F(\text{max}) = 115^\circ\text{C}$	–	-20 to 125	$^\circ\text{C}$	
Storage Temperature	T_{stg}		–	-40 to 125	$^\circ\text{C}$	
Channel Temperature	T_{ch}		–	150	$^\circ\text{C}$	

¹Current characteristics are defined based on IC as sink (+), or source (-).

²Refer to MOSFET Safe Operating Area Curve.

³Refer to MOSFET Avalanche Energy Derating Coefficient Curve.

⁴Refer to MOSFET Temperature versus Power Dissipation Curve.

Functional Block Diagram

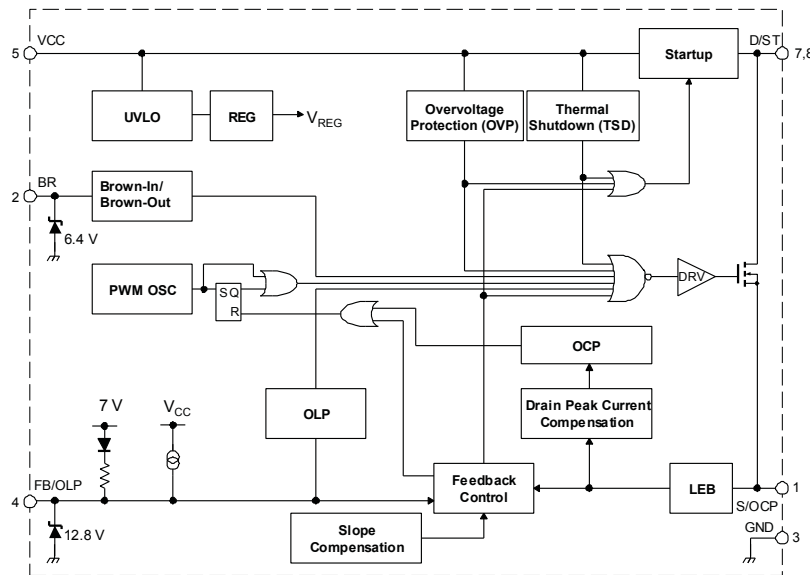

Pin-out Diagram

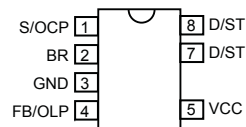

Terminal List Table

Number	Name	Function
1	S/OCP	MOSFET source, and input for Overcurrent Protection detection signal
2	BR	Input for Brown-In and Brown-Out Protection detection voltage
3	GND	Ground
4	FB/OLP	Input for constant voltage control signal, and input for Overload Protection signal
5	VCC	Input for power supply for control circuit
6	–	(Pin removed)
7, 8	D/ST	MOSFET drain, and input for startup current

Electrical Characteristics¹ Valid at $V_{CC} = 18\text{ V}$, $T_A = 25^\circ\text{C}$, unless otherwise specified

Characteristic	Symbol	Terminal	Min.	Typ.	Max.	Unit
Operation Start Voltage	$V_{CC(ON)}$	5 – 3	13.8	15.3	16.8	V
Operation Stop Voltage ²	$V_{CC(OFF)}$	5 – 3	7.3	8.1	8.9	V
Circuit Current in Operation	$I_{CC(ON)}$	5 – 3	–	–	2.5	mA
Minimum Startup Voltage	$V_{ST(ON)}$	5 – 3	–	38	–	V
Startup Current	$I_{STARTUP}$	5 – 3	–3.7	–2.5	–1.5	mA
Startup Current Supply Threshold Voltage ²	$V_{CC(BIAS)}$	5 – 3	8.5	9.5	10.5	V
Average Switching Frequency	$f_{OSC(av)}$	8 – 3	90	100	110	kHz
Switching Frequency Variance Range	Δf	8 – 3	–	8	–	kHz
Maximum Duty Cycle	D_{MAX}	8 – 3	77	83	89	%
Minimum On-Time	$t_{ON(MIN)}$	–	–	470	–	ns
Leading Edge Blanking Time	t_{BW}	–	–	280	–	ns
OCP Compensation Coefficient	D_{PC}	–	–	33	–	mV/ μs
Maximum Duty Cycle for OCP Compensation	D_{DPC}	–	–	36	–	%
OCP Threshold Voltage at Zero Duty Cycle	$V_{OCP(L)}$	1 – 3	0.70	0.78	0.86	V
OCP Threshold Voltage at 36% Duty Cycle	$V_{OCP(H)}$	1 – 3	0.81	0.9	0.99	V
Maximum Feedback Current	$I_{FB(MAX)}$	4 – 3	–340	–230	–150	μA
Minimum Feedback Current	$I_{FB(MIN)}$	4 – 3	–30	–15	–7	μA
Oscillation Stop FB/OLP Voltage	$V_{FB(OFF)}$	4 – 3	0.85	0.95	1.05	V
OLP Threshold Voltage	$V_{FB(OLP)}$	4 – 3	7.3	8.1	8.9	V
OLP Delay Time	t_{OLP}	4 – 3	54	68	82	ms
Operation Current After OLP	$I_{CC(OLP)}$	5 – 3	–	300	600	μA
FB/OLP Terminal Clamp Voltage	$V_{FB(CLAMP)}$	4 – 3	11	12.8	14	V
Brown-In Threshold Voltage	$V_{BR(IN)}$	2 – 3	5.2	5.6	6	V
Brown-Out Threshold Voltage	$V_{BR(OUT)}$	2 – 3	4.45	4.8	5.15	V
BR Terminal Clamp Voltage	$V_{BR(CLAMP)}$	2 – 3	6	6.4	7	V
BR Function Disabling Threshold	$V_{BR(DIS)}$	2 – 3	0.3	0.48	0.7	V
OVP Threshold Voltage	$V_{CC(OVP)}$	5 – 3	26	29	32	V
Latch Circuits Sustaining Current ³	$I_{CC(LATCH)}$	5 – 3	–	700	–	μA
Thermal Shutdown Operating Temperature	$T_{J(TSD)}$	5 – 3	135	–	–	$^\circ\text{C}$

¹Current characteristics are defined based on IC as sink (+), or source (–).

² $V_{CC(BIAS)} > V_{CC(OFF)}$.

³A latch circuit is a circuit operated with Overvoltage Protection (OVP) and/or Thermal Shutdown Protection (TSD) in operation.

MOSFET Electrical Characteristics Valid at $T_A = 25^\circ\text{C}$, unless otherwise specified

Characteristic	Symbol	Device	Terminal	Min.	Typ.	Max.	Unit
Drain-to-Source Breakdown Voltage	V_{DSS}	STR-A6059H	8 – 1	650	–	–	V
		STR-A6062H	8 – 1	700	–	–	V
		STR-A6069H	8 – 1	700	–	–	V
Drain Leakage Current	I_{DSS}	All	8 – 1	–	–	300	μA
On-Resistance	$R_{DS(on)}$	STR-A6059H	8 – 1	–	–	6	Ω
		STR-A6062H	8 – 1	–	–	2.8	Ω
		STR-A6069H	8 – 1	–	–	6	Ω
Switching Time	t_f	All	8 – 1	–	–	250	ns
Thermal Resistance*	$R_{\theta chC}$	All	–	–	–	22	$^\circ\text{C/W}$

*Case temperature, T_C , is defined at the center of surface on the branded side of the package.

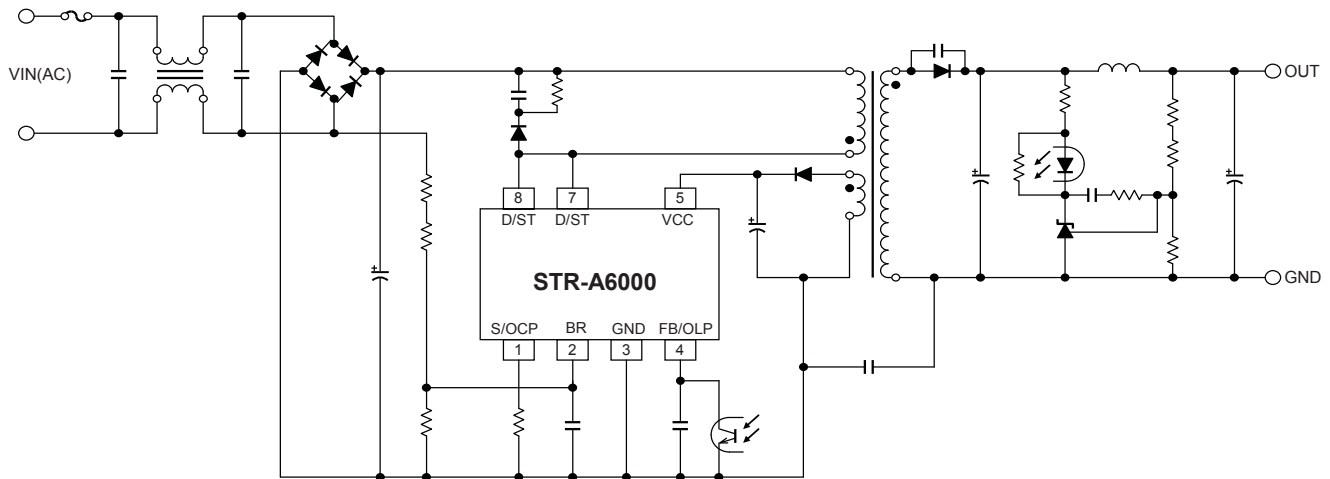

Typical application circuit example. Brown-in/Brown-out function enabled by connecting the BR terminal to a resistive divider

Characteristic Performance STR-A6059H

S. O. A. Temperature Derating Coefficient Curve

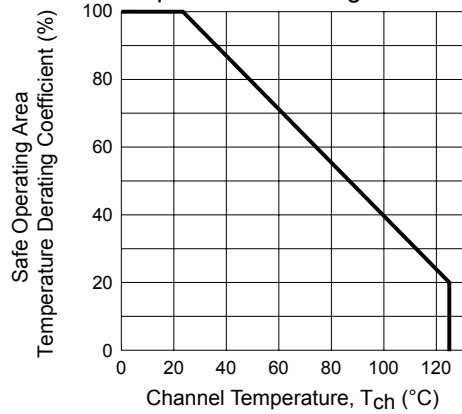

MOSFET Safe Operating Area Curve

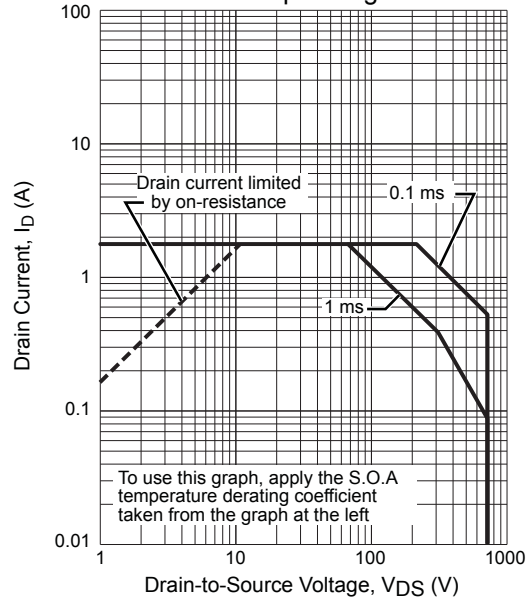

MOSFET Avalanche Energy Derating Coefficient Curve

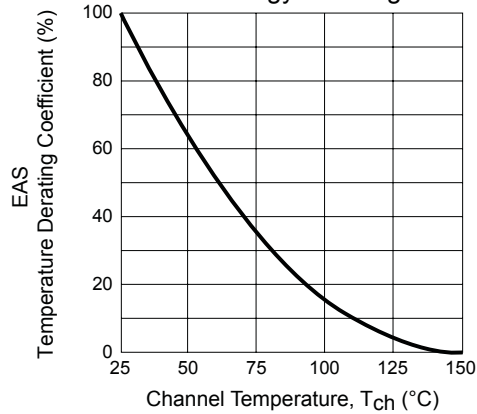

MOSFET Temperature versus Power Dissipation Curve

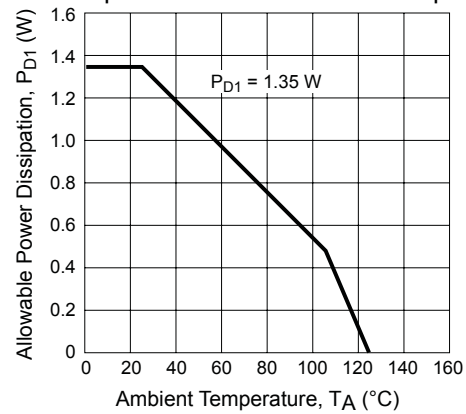

Transient Thermal Resistance Curve

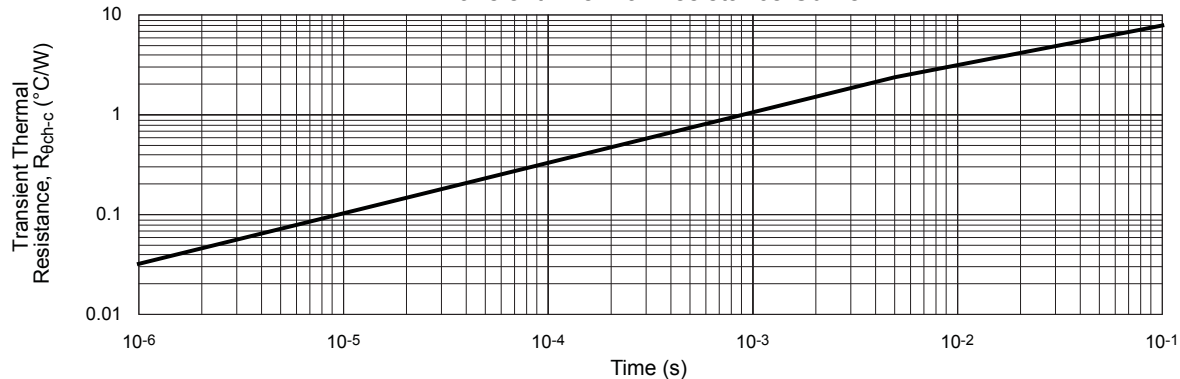

Characteristic Performance STR-A6062H

S. O. A. Temperature Derating Coefficient Curve

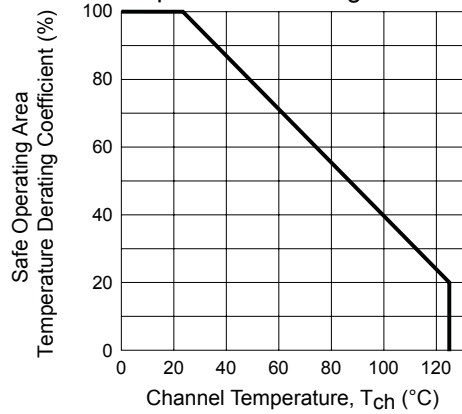

MOSFET Safe Operating Area Curve

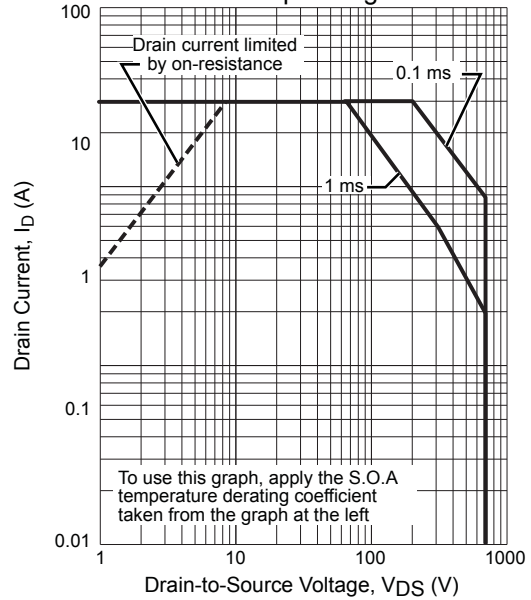

MOSFET Avalanche Energy Derating Coefficient Curve

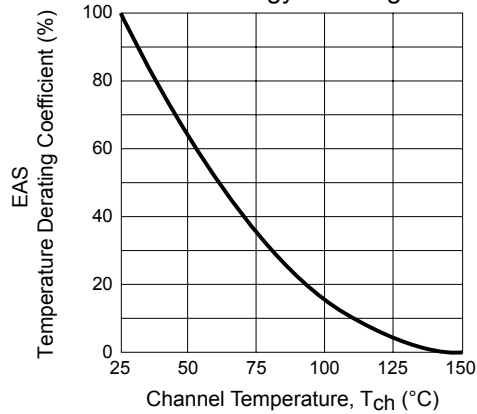

MOSFET Temperature versus Power Dissipation Curve

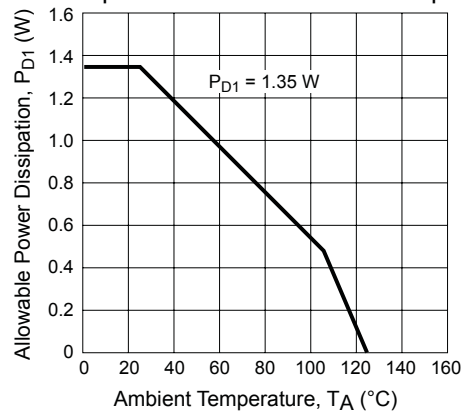

Transient Thermal Resistance Curve

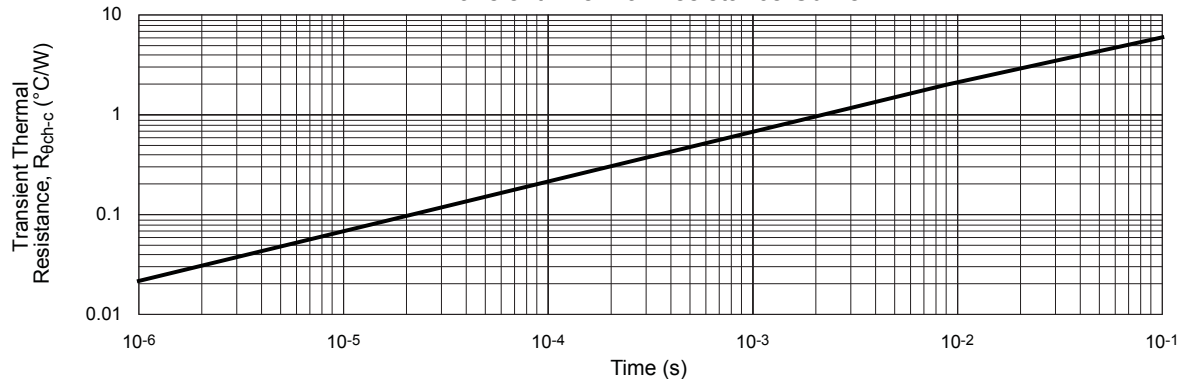

Characteristic Performance STR-A6069H

S. O. A. Temperature Derating Coefficient Curve

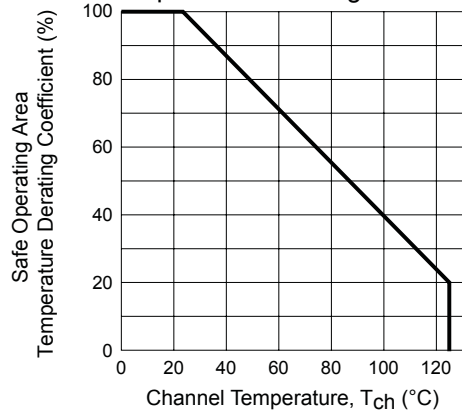

MOSFET Safe Operating Area Curve

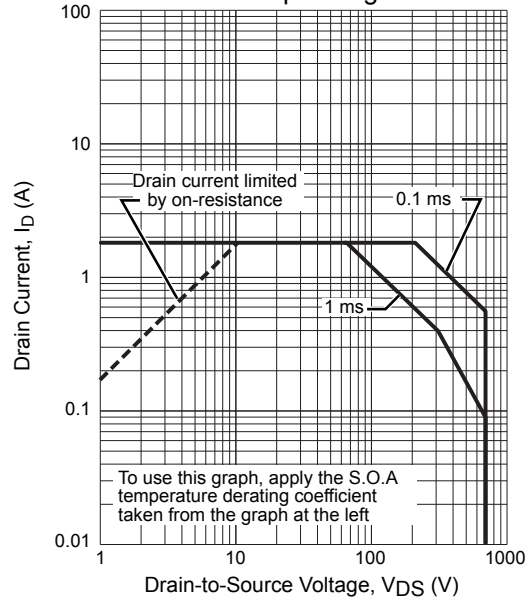

MOSFET Avalanche Energy Derating Coefficient Curve

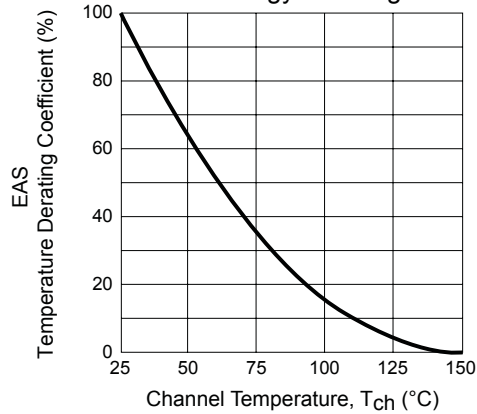

MOSFET Temperature versus Power Dissipation Curve

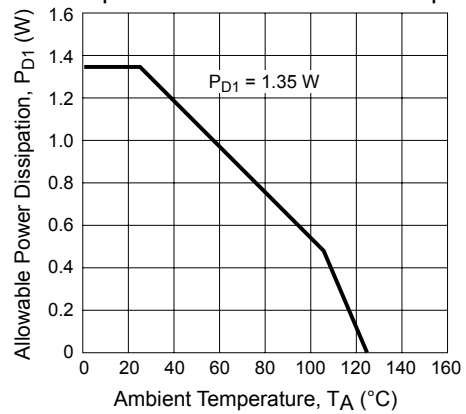

Transient Thermal Resistance Curve

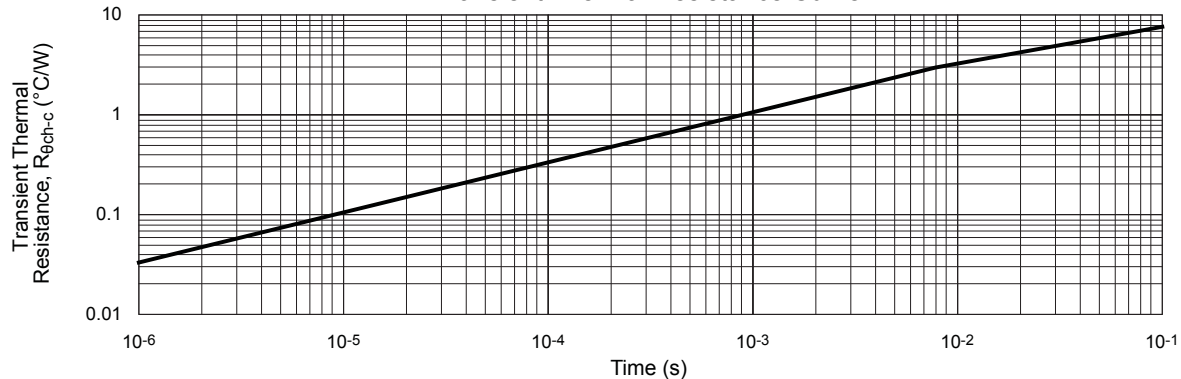

Package Outline Drawing, DIP-8

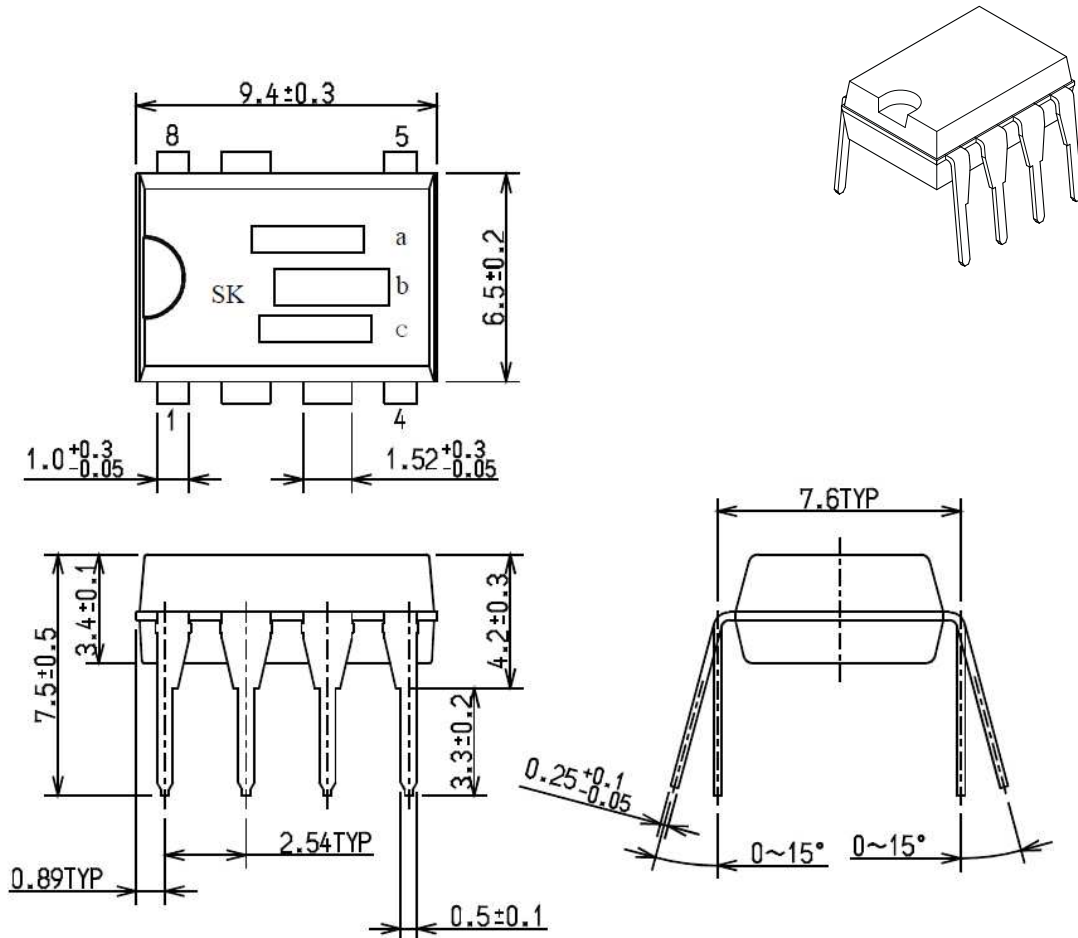

Material of terminal: Cu
Treatment of terminal: Solder plating (Pb-free)
Weight: Approximately 0.51 g
Unit: mm

- a. Type Number: A60**
b. Lot Number:
1st letter: Last digit of year
2nd letter: Month
1 to 9 for Jan. to Sept.
O for Oct.
N for Nov.
D for Dec.
3rd letter: Week
c. Sanken Registration Number

Appearance: The body shall be clean and shall not bear any stain, rust, or flaw.

Marking: The type number and lot number shall be clearly marked.



Leadframe plating Pb-free. Device composition compliant with the RoHS directive.

Packing Specifications

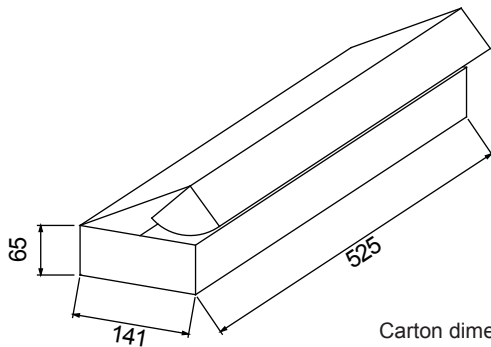
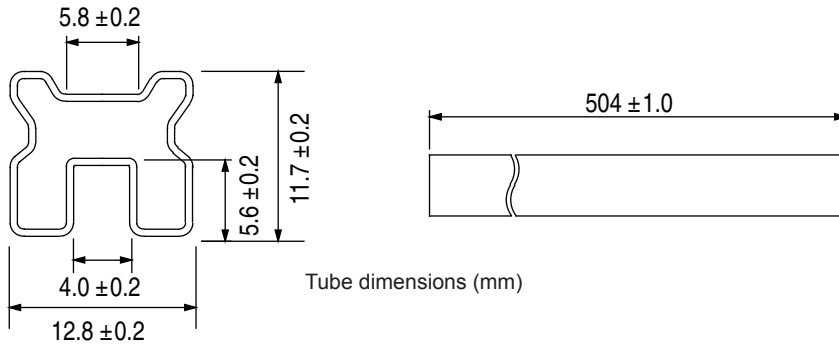
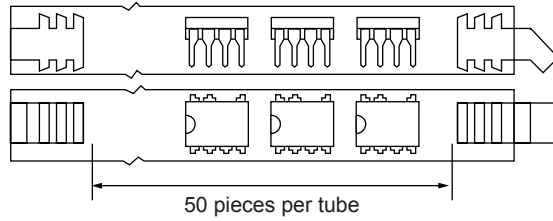

50 tubes per inner carton (maximum)
2500 pieces maximum per inner carton

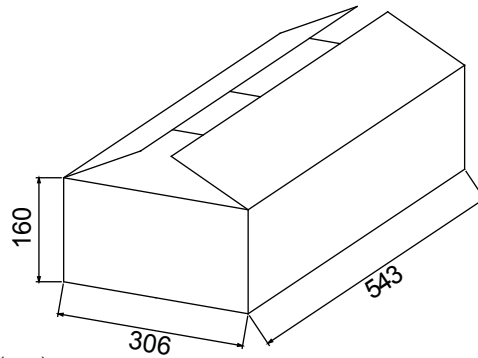

4 inner cartons per outer carton (maximum)
10,000 pieces maximum per outer carton

Because reliability can be affected adversely by improper storage environments and handling methods, please observe the following cautions.

Cautions for Storage

- Ensure that storage conditions comply with the standard temperature (5°C to 35°C) and the standard relative humidity (around 40% to 75%); avoid storage locations that experience extreme changes in temperature or humidity.
- Avoid locations where dust or harmful gases are present and avoid direct sunlight.
- Reinspect for rust on leads and solderability of products that have been stored for a long time.

Cautions for Testing and Handling

When tests are carried out during inspection testing and other standard test periods, protect the products from power surges from the testing device, shorts between the product pins, and wrong connections.

Remarks About Using Silicone Grease with a Heatsink

- When silicone grease is used in mounting this product on a heatsink, it shall be applied evenly and thinly. If more silicone grease than required is applied, it may produce excess stress.
- Volatile-type silicone greases may crack after long periods of time, resulting in reduced heat radiation effect. Silicone grease with low consistency (hard grease) may cause cracks in the mold resin when screwing the product to a heatsink.
- Our recommended silicone greases for heat radiation purposes, which will not cause any adverse effect on the product life, are indicated below:

Type	Suppliers
G746	Shin-Etsu Chemical Co., Ltd.
YG6260	Momentive Performance Materials Holding, Inc.
SC102	Dow Corning Toray Co., Ltd.

Soldering

- Leadframe temperature, T_F , should not exceed 115°(max)
- When soldering the products, please be sure to minimize the working time, within the following limits:
260±5°C 10 s
350±5°C 3 s (solder iron)
- To avoid internal chip damage, soldering on each of the lead-pins should be at a distance of at least 1.5 mm away from the body of the products.

Electrostatic Discharge

- When handling the products, the operator must be grounded. Grounded wrist straps worn should have at least 1 MΩ of resistance from the operator to ground to prevent shock hazard, and it should be placed near the operator.
- Workbenches where the products are handled should be grounded and be provided with conductive table and floor mats.
- When using measuring equipment such as a curve tracer, the equipment should be grounded.
- When soldering the products, the head of soldering irons or the solder bath must be grounded in order to prevent leak voltages generated by them from being applied to the products.
- The products should always be stored and transported in Sanken shipping containers or conductive containers, or be wrapped in aluminum foil.

The products described herein are manufactured in Japan by Sanken Electric Co., Ltd. for sale by Allegro MicroSystems, Inc.

Sanken and Allegro reserve the right to make, from time to time, such departures from the detail specifications as may be required to permit improvements in the performance, reliability, or manufacturability of its products. Therefore, the user is cautioned to verify that the information in this publication is current before placing any order.

When using the products described herein, the applicability and suitability of such products for the intended purpose shall be reviewed at the users responsibility.

Application and operation examples described in this document are quoted for the sole purpose of reference for the use of the products herein and Sanken can assume no responsibility for any infringement of industrial property rights, intellectual property rights or any other rights of Sanken, Allegro, or any third party which may result from its use.

When using the products specified herein by either (i) combining other products or materials therewith or (ii) physically, chemically or otherwise processing or treating the products, please duly consider all possible risks that may result from all such uses in advance and proceed therewith at your own responsibility.

Although Sanken undertakes to enhance the quality and reliability of its products, the occurrence of failure and defect of semiconductor products at a certain rate is inevitable. Users of Sanken products are requested to take, at their own risk, preventative measures including safety design of the equipment or systems against any possible injury, death, fires or damages to the society due to device failure or malfunction.

Sanken products listed in this document are designed and intended for the use as components in general purpose electronic equipment or apparatus (home appliances, office equipment, telecommunication equipment, measuring equipment, etc.). Please return to us this document with your signature(s) or seal(s) prior to the use of the products herein.

When considering the use of Sanken products in the applications where higher reliability is required (traffic signal control systems or equipment, fire/ crime alarm systems, various safety devices, etc.), please contact your nearest Sanken sales representative to discuss, and then return to us this document with your signature(s) or seal(s) prior to the use of the products herein.

The use of Sanken products without the written consent of Sanken in the applications where extremely high reliability is required (aerospace equipment, nuclear power control systems, life support systems, etc.) is strictly prohibited.

Anti radioactive ray design is not considered for the products listed herein.

The information included herein is believed to be accurate and reliable. Application and operation examples described in this publication are given for reference only and Sanken and Allegro assume no responsibility for any infringement of industrial property rights, intellectual property rights, or any other rights of Sanken or Allegro or any third party that may result from its use. The contents in this document must not be transcribed or copied without Sanken's written consent.

Sanken assumes no responsibility for any troubles, such as dropping products caused during transportation out of Sanken's distribution network.