

TQP3M9028

High Linearity LNA Gain Block

Applications

- Repeaters
- Mobile Infrastructure
- Defense/Aerospace
- LTE / WCDMA / EDGE / CDMA
- General Purpose Wireless
- IF amplifier, RF driver amplifier



SOT-89 Package

Product Features

- 50-4000 MHz
- Flat gain (14.7 ± 0.3 dB) from 0.5 – 3.5 GHz
- +40 dBm Output IP3
- 2 dB Noise Figure @ 1.9 GHz
- No RF component needed; 50 Ω gain block
- Unconditionally stable
- +5V Single Supply, 85 mA Current
- SOT-89 Package

Functional Block Diagram

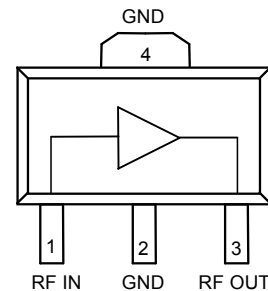

General Description

The TQP3M9028 is a cascadable, high linearity gain block amplifier in a low-cost surface-mount package. At 1.9 GHz, the amplifier typically provides 14.7 dB gain, +40 dBm OIP3, and 2 dB Noise Figure while only drawing 85 mA current. The device is housed in a leadfree/green/RoHS-compliant industry-standard SOT-89 package.

The TQP3M9028 has the benefit of having excellent gain flatness across a broad range of frequencies. The low noise figure and high linearity performance allows the device to be used in both receiver and transmitter chains for high performance systems. The amplifier is internally matched using a high performance E-pHEMT process and only requires an external RF choke and blocking/bypass capacitors for operation from a single +5V supply. The internal active bias circuit also enables stable operation over bias and temperature variations.

The TQP3M9028 covers the 0.05-4 GHz frequency band and is targeted for wireless infrastructure or other applications requiring high linearity and/or low noise figure.

Pin Configuration

Pin #	Symbol
1	RF Input
3	RF Output / V_{dd}
2, 4	Ground

Ordering Information

Part No.	Description
TQP3M9028	High Linearity LNA Gain Block
TQP3M9028-PCB_IF	TQP3M9028 EVB 0.05-0.5 GHz
TQP3M9028-PCB_RF	TQP3M9028 EVB 0.5-4 GHz

Standard T/R size = 1000 pieces on a 7" reel.

Specifications

Absolute Maximum Ratings

Parameter	Rating
Storage Temperature	-65 to +150 °C
RF Input Power, CW, 50 Ω, T = 25°C	+23 dBm
Device Voltage, V _{dd}	+7 V
Reverse Device Voltage	-0.3V

Operation of this device outside the parameter ranges given above may cause permanent damage.

Recommended Operating Conditions

Parameter	Min	Typ	Max	Units
V _{dd}	+4.75	+5	+5.25	V
T _{case}	-40		85	°C
T _j (for >10 ⁶ hours MTTF)			190	°C

Electrical specifications are measured at specified test conditions. Specifications are not guaranteed over all recommended operating conditions.

Electrical Specifications

Test conditions unless otherwise noted: +25°C, +5V V_{supply}, 50 Ω system.

Parameter	Conditions	Min	Typical	Max	Units
Operational Frequency Range		50		4000	MHz
Test Frequency			1900		MHz
Gain		13	14.5	16	dB
Input Return Loss			18		dB
Output Return Loss			19		dB
Output P1dB			+20.7		dBm
Output IP3	See Note 1.	+36	+40		dBm
Noise Figure			2		dB
V _{dd}			+5		V
Current, I _{dd}			85	100	mA
Thermal Resistance (jnc to case) θ _{jc}			36.6		°C/W

Notes

- OIP3 measured with two tones at an output power of +4 dBm / tone separated by 1 MHz. The suppression on the largest IM3 product is used to calculate the OIP3 using 2:1 rule.

TQP3M9028

High Linearity LNA Gain Block



Device Characterization

$V_{dd} = +5\text{ V}$, $I_{dd} = 85\text{ mA}$, $T = +25\text{ }^{\circ}\text{C}$, calibrated to device leads

Freq (MHz)	S11 (dB)	S11 (ang)	S21 (dB)	S21 (ang)	S12 (dB)	S12 (ang)	S22 (dB)	S22 (ang)
50	-17.781	-79.977	16.426	168.24	-19.626	4.3045	-19.220	-103.67
100	-20.687	-111.11	15.710	165.75	-19.125	-0.3832	-19.244	-133.67
200	-23.728	-139.82	15.333	161.88	-18.801	-5.7231	-19.718	-156.97
400	-26.055	-167.83	15.114	150.42	-19.148	-15.433	-20.556	179.38
600	-27.432	-174.22	15.068	138.49	-19.086	-24.010	-22.047	170.39
800	-28.336	175.58	14.970	124.69	-19.086	-32.722	-22.058	163.66
1000	-28.090	168.62	14.889	112.00	-19.259	-42.486	-23.024	152.72
1200	-27.851	173.63	14.837	98.392	-19.196	-50.978	-24.702	147.54
1400	-27.744	-176.1	14.787	85.391	-19.461	-59.544	-27.618	150.45
1600	-25.498	-170.21	14.785	71.784	-19.643	-67.665	-30.371	178.07
1800	-23.299	-171.85	14.681	58.795	-19.718	-76.829	-30.117	-137.55
2000	-21.873	-177.68	14.742	45.335	-19.786	-86.241	-24.898	-137.73
2200	-19.991	174.69	14.585	31.380	-20.202	-94.784	-21.473	-136.81
2400	-18.395	168.24	14.660	17.730	-20.964	-105.89	-18.570	-137.28
2600	-16.954	156.32	14.540	3.3697	-20.584	-113.76	-16.815	-144.20
2800	-15.635	143.92	14.468	-10.871	-21.081	-123.83	-15.001	-146.29
3000	-14.526	132.69	14.390	-25.665	-21.170	-134.66	-13.630	-160.04
3200	-13.585	121.19	14.321	-40.604	-21.463	-143.32	-12.590	-169.39
3400	-13.396	109.54	14.295	-55.994	-21.608	-153.10	-11.447	-179.44
3600	-13.267	95.204	14.103	-71.813	-22.114	-164.82	-10.288	168.78
3800	-13.490	73.954	14.022	-88.474	-22.248	-174.45	-9.8699	161.57
4000	-13.580	51.354	13.694	-105.82	-22.604	175.38	-9.6061	156.49

TQP3M9028

High Linearity LNA Gain Block

Application Circuit Configuration

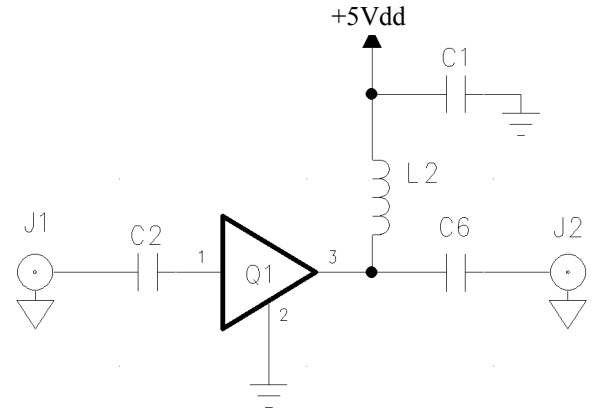
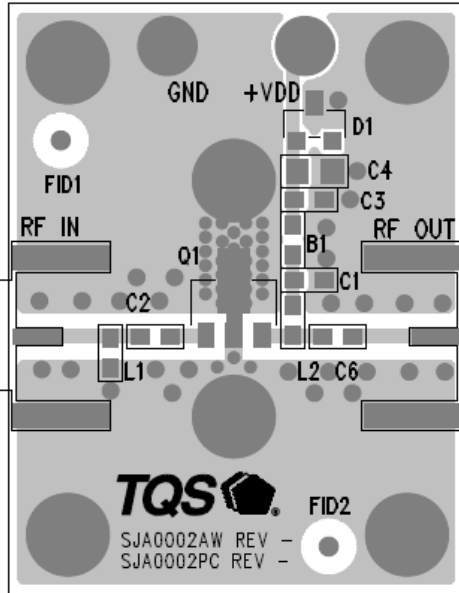

Notes:

1. See PC Board Layout, page 9 for more information.
2. Components shown on the silkscreen but not on the schematic are not used.
3. B1 (0 Ω jumper) may be replaced with copper trace in the target application layout.
4. The recommended component values are dependent upon the frequency of operation.
5. All components are of 0603 size unless stated on the schematic.

Bill of Material

Reference Designation	Frequency (MHz)	
	TQP3M9028-PCB_IF	TQP3M9028-PCB_RF
	50 - 500	500 - 4000
Q1	TQP3M9028	
C2, C6	1000 pF	100 pF
C1	0.01 uF	0.01 uF
L2	330 nH	68 nH
L1, D1, C3, C4	Do Not Place	
B1	0 Ω	

Notes:

1. Performances can be optimized at frequency of interest by using recommended component values shown in the table below.

Reference Designation	Frequency (MHz)			
	500	2000	2500	3500
C2, C6	100 pF	22 pF	22 pF	22 pF
L2	82 nH	22 nH	18 nH	15 nH

TQP3M9028

High Linearity LNA Gain Block



Typical Performance 500-4000 MHz

Test conditions unless otherwise noted: +25°C, +5V, 85 mA, 50 Ω system. The data shown below is measured on TQP3M9028-PCB_RF.

Frequency	MHz	500	900	1900	2700	3500	4000
Gain	dB	15.2	15.1	14.7	14.4	14.6	14.2
Input Return Loss	dB	19	24	18	16	17	12
Output Return Loss	dB	17.5	21	19	14	16	16.5
Output P1dB	dBm	+21.3	+21.4	+20.7	+19.8	+19.6	+18.1
OIP3 [1]	dBm	+40.6	+40.1	+40.3	+36.2	+33.2	+29
Noise Figure [2]	dB	1.8	2	2	2.5		

Notes:

- OIP3 measured with two tones at an output power of +4 dBm / tone separated by 1 MHz. The suppression on the largest IM3 product is used to calculate the OIP3 using 2:1 rule.
- Noise figure data shown in the table above is measured on evaluation board which includes board losses of 0.1dB @ 2 GHz.

RF Performance Plots

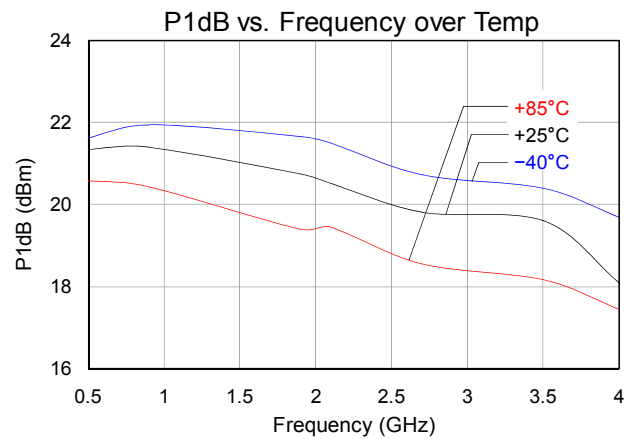
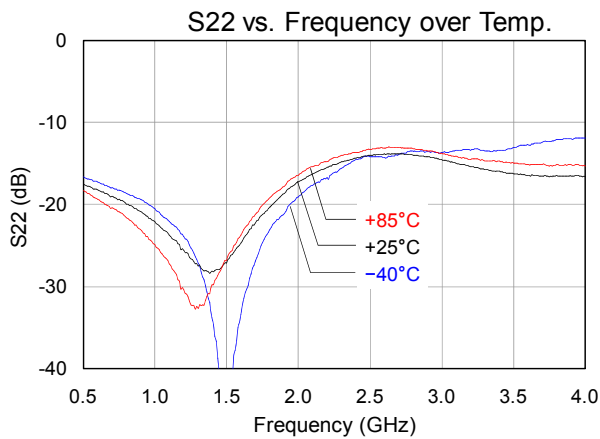
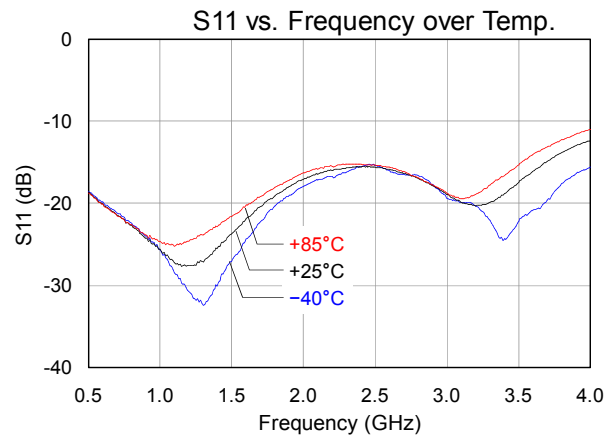
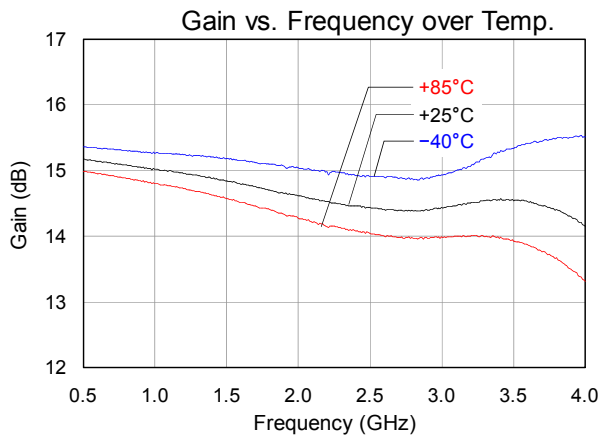

TQP3M9028

High Linearity LNA Gain Block



RF Performance Plots (cont.)

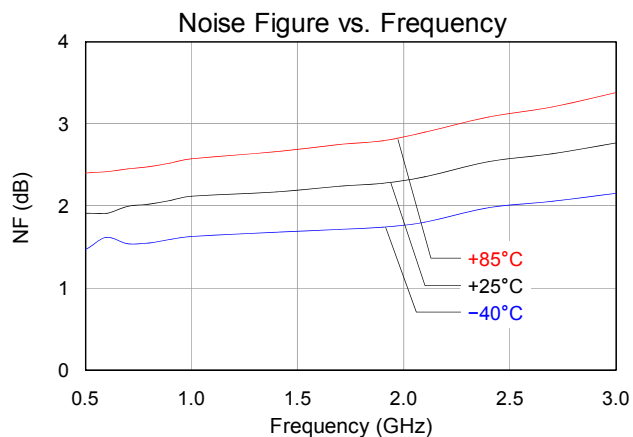
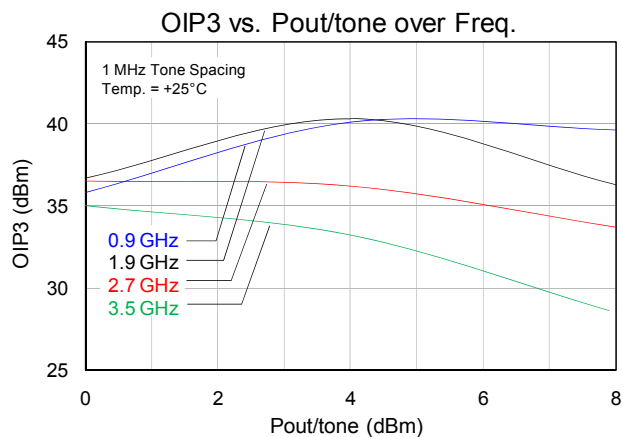
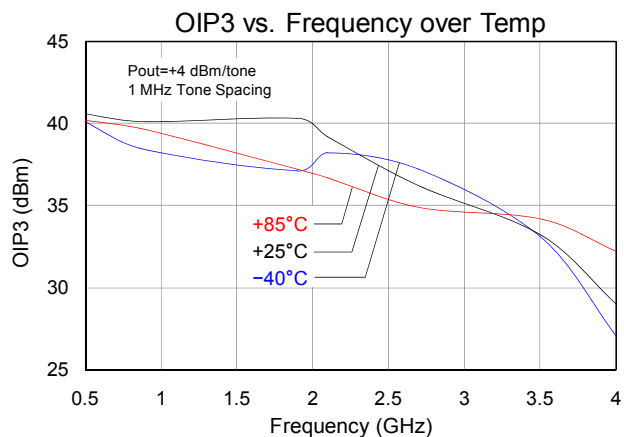
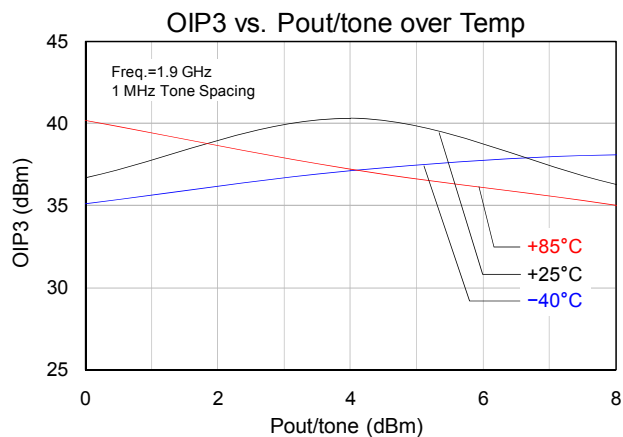

TQP3M9028

High Linearity LNA Gain Block



Typical Performance 50-500 MHz

Test conditions unless otherwise noted: +25°C, +5V, 85 mA, 50 Ω system. The data shown below is measured on TQP3M9028-PCB_IF.

Frequency	MHz	70	100	200	500
Gain	dB	15.8	15.5	15.3	15.2
Input Return Loss	dB	13	15	20	25
Output Return Loss	dB	23	23	22	20.5
Output P1dB	dBm	+20.6	+20.6	+21.0	+21.2
OIP3 [1]	dBm	+40.3	+40.5	+41.9	+39.9
Noise Figure [2]	dB	1.8	1.7	1.7	1.8

Notes:

- OIP3 measured with two tones at an output power of +6 dBm / tone separated by 1 MHz. The suppression on the largest IM3 product is used to calculate the OIP3 using 2:1 rule.
- Noise figure data shown in the table above is measured on evaluation board which includes board losses of 0.1 dB @ 2 GHz.

IF Performance Plots

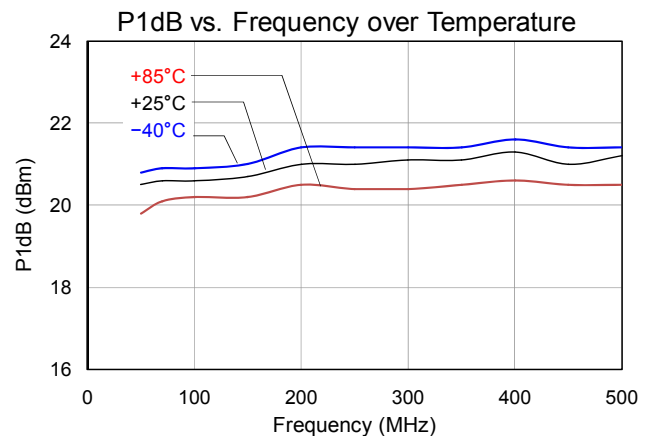
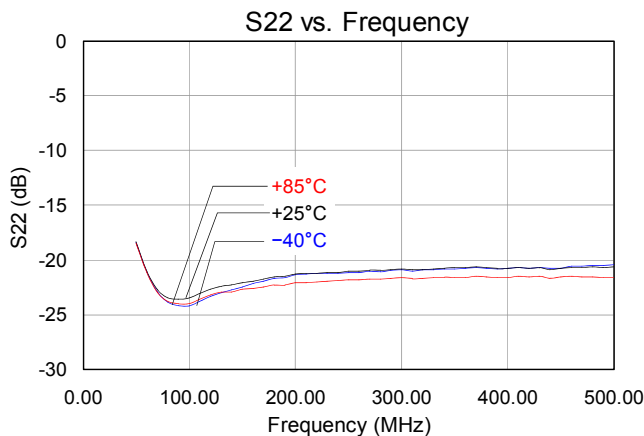
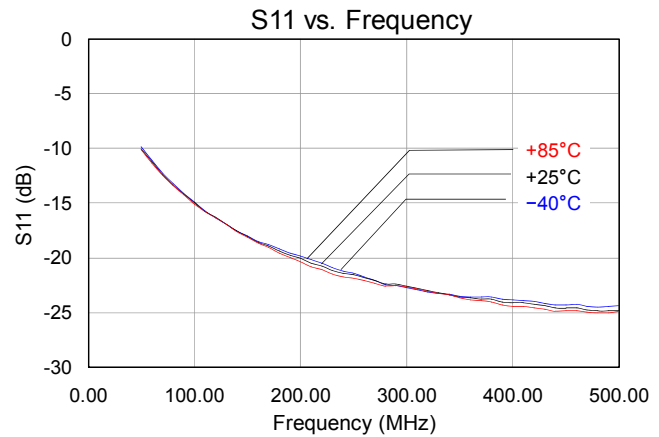
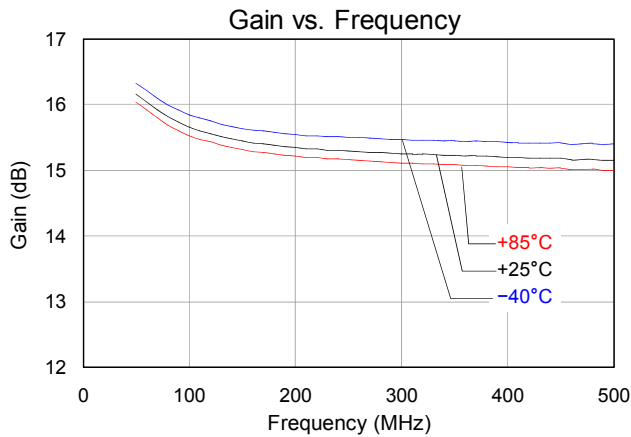

IF Performance Plots (cont.)

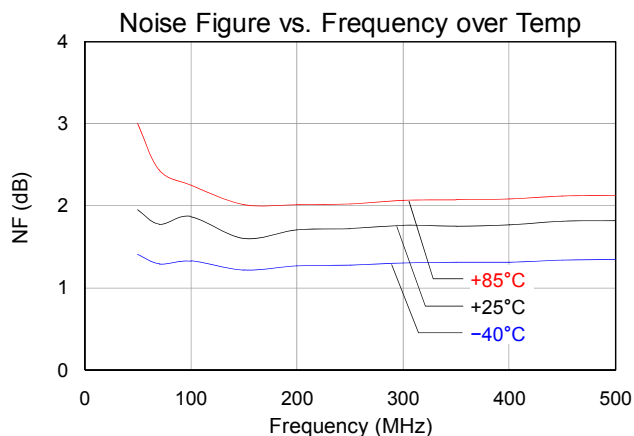
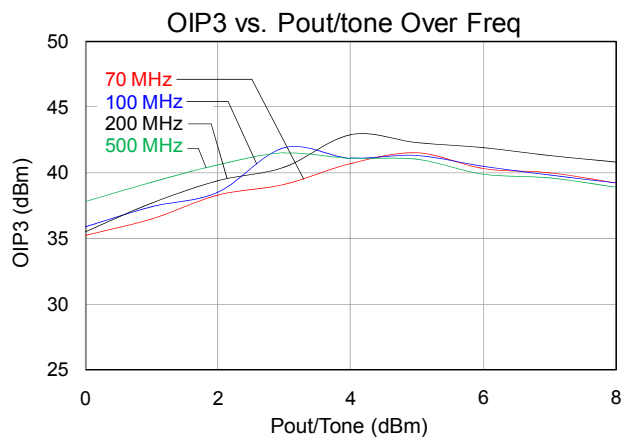
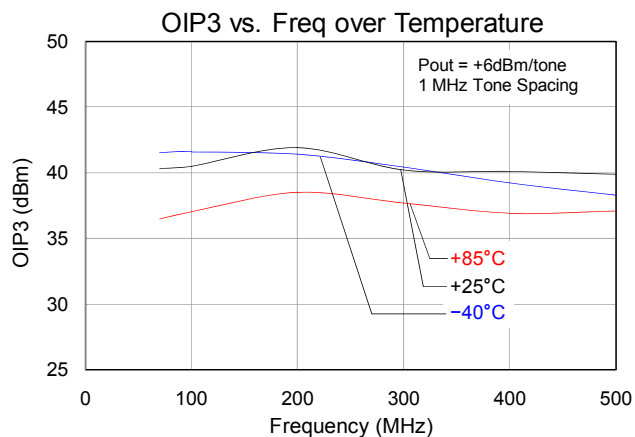

TQP3M9028

High Linearity LNA Gain Block

Pin Configuration and Description

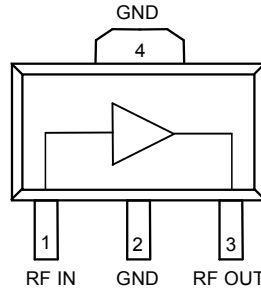

Pin	Symbol	Description
1	RF IN	Input, matched to 50 ohms. External DC Block is required.
2, 4	GND	RF/DC Ground Connection
3	RFout / Vdd	Output, matched to 50 ohms, External DC Block is required and supply voltage

Applications Information

PC Board Layout

Top RF layer is .014" NELCO N4000-13, $\epsilon_r = 3.9$, 4 total layers (0.062" thick) for mechanical rigidity. Metal layers are 1-oz copper. 50 ohm Microstrip line details: width = .029", spacing = .035".

The pad pattern shown has been developed and tested for optimized assembly at TriQuint Semiconductor. The PCB land pattern has been developed to accommodate lead and package tolerances. Since surface mount processes vary from supplier to supplier, careful process development is recommended.

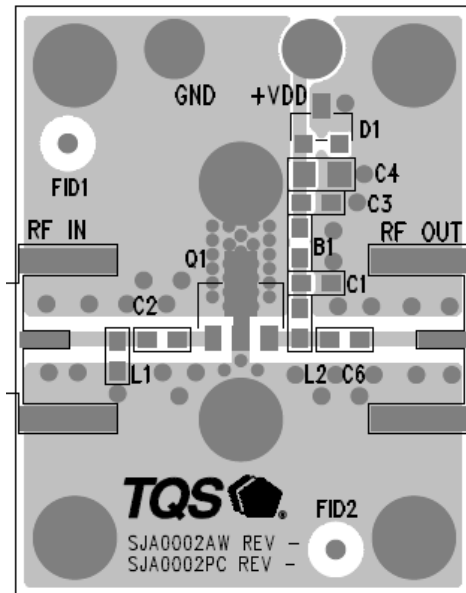

TQP3M9028

High Linearity LNA Gain Block



Mechanical Information

Package Information and Dimensions

The component will be marked with a "3M9028" designator with an alphanumeric lot code on the top surface of package. The "Y" represents the last digit of the year the part was manufactured; the "XXX" is an auto generated number.

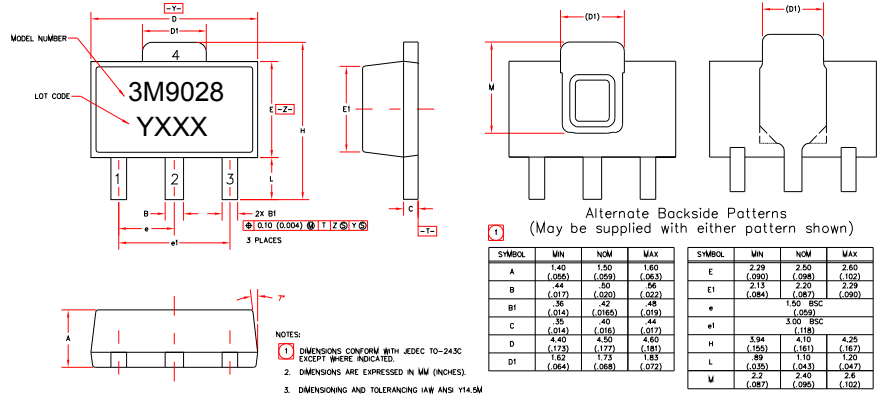

Mounting Configuration

All dimensions are in millimeters (inches). Angles are in degrees.

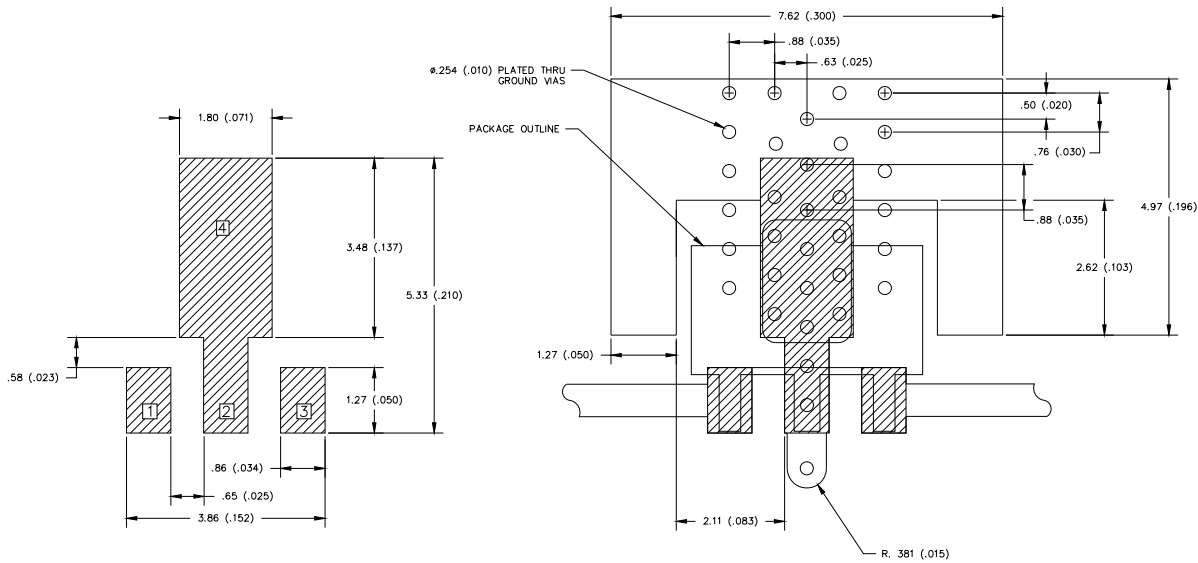

Notes:

- Ground / thermal vias are critical for the proper performance of this device. Vias should use a .35mm (#80 / .0135") diameter drill and have a final plated thru diameter of .25 mm (.010").
- Add as much copper as possible to inner and outer layers near the part to ensure optimal thermal performance.
- RF trace width depends upon the PC board material and construction.
- Use 1 oz. Copper minimum.

Product Compliance Information

ESD Information



Caution! ESD-Sensitive Device

ESD Rating: Class 1A
Value: Passes $\geq 250V$ to $< 500 V$
Test: Human Body Model (HBM)
Standard: JEDEC Standard JESD22-A114

ESD Rating: CDM Class IV
Value: Passes $\geq 1000 V$
Test: Charged Device Model (CDM)
Standard: JEDEC Standard JESD22-C101

MSL Rating

The part is rated Moisture Sensitivity Level 3 at 260°C per JEDEC standard IPC/JEDEC J-STD-020.

Solderability

This package is lead-free/RoHS-compliant. The plating material on the leads is NiPdAu. It is compatible with both lead-free (maximum 260 °C reflow temperature) and lead (maximum 245 °C reflow temperature) soldering processes.

This part is compliant with EU 2002/95/EC RoHS directive (Restrictions on the Use of Certain Hazardous Substances in Electrical and Electronic Equipment).

This product also has the following attributes:

- Lead Free
- Halogen Free (Chlorine, Bromine)
- Antimony Free
- TBBP-A ($C_{15}H_{12}Br_4O_2$) Free
- PFOS Free
- SVHC Free

Contact Information

For the latest specifications, additional product information, worldwide sales and distribution locations, and information about TriQuint:

Web: www.triquint.com
Email: info-sales@tqs.com

Tel: +1.503.615.9000
Fax: +1.503.615.8902

For technical questions and application information:

Email: sjcapplications.engineering@tqs.com

Important Notice

The information contained herein is believed to be reliable. TriQuint makes no warranties regarding the information contained herein. TriQuint assumes no responsibility or liability whatsoever for any of the information contained herein. TriQuint assumes no responsibility or liability whatsoever for the use of the information contained herein. The information contained herein is provided "AS IS, WHERE IS" and with all faults, and the entire risk associated with such information is entirely with the user. All information contained herein is subject to change without notice. Customers should obtain and verify the latest relevant information before placing orders for TriQuint products. The information contained herein or any use of such information does not grant, explicitly or implicitly, to any party any patent rights, licenses, or any other intellectual property rights, whether with regard to such information itself or anything described by such information.

TriQuint products are not warranted or authorized for use as critical components in medical, life-saving, or life-sustaining applications, or other applications where a failure would reasonably be expected to cause severe personal injury or death.