

12 - 16 GHz High Linearity Amplifier

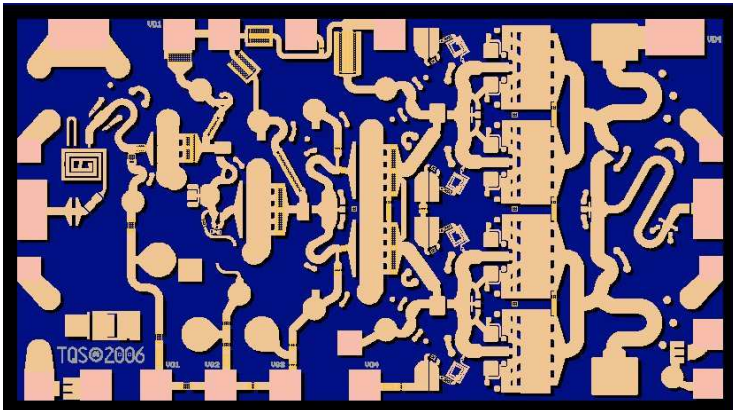

Key Features and Performance

- 31 dBm Midband Pout
- 33 dB Nominal Gain
- TOI > 40 dBm
- 0.5 μm pHEMT 3MI Technology
- Bias Conditions: 6 V, 850mA
- Chip dimensions: 2.5 x 1.4 x 0.1 mm (98 x 55 x 4 mils)

Preliminary Measured Data

Bias Conditions: Vd=6 V Id=850 mA

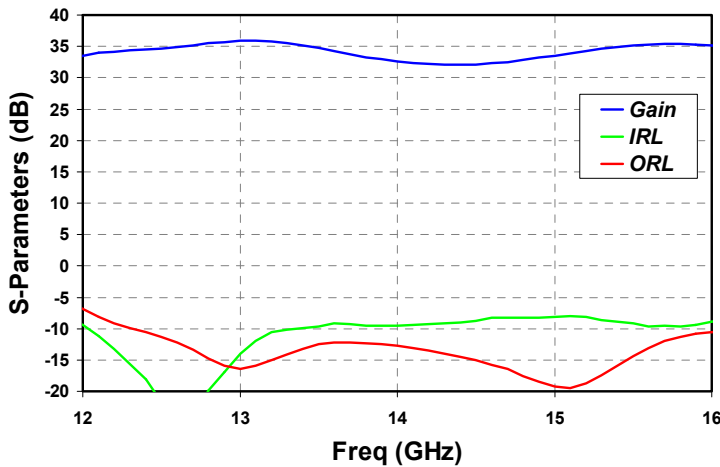

Primary Applications

- Point-to-Point Radio
- VSAT
- Ku Band Sat-Com

Product Description

The TriQuint TGA2520 MMIC is an extremely linear, high gain amplifier, capable of 1 Watt output power at P1dB for the frequency range of 12 – 16 GHz. This performance makes this amplifier ideally suited for Point to Point Radios and current Ku-Band satellite ground terminal applications. The TGA2520 utilizes TriQuint’s robust 0.5um power pHEMT process coupled with 3 layer Metal Inteconnect (3MI) technology. The TGA2520 provides the high power transmit function in an extremely compact (< 3.5mm²) chip footprint.

The combination of a high-yield process, electrical performance, and compact die size is exactly what is required to support the aggressive pricing targets required for low-cost transmit modules. Each device is 100% DC and RF tested on-wafer to ensure performance compliance. The device is available in chip form.

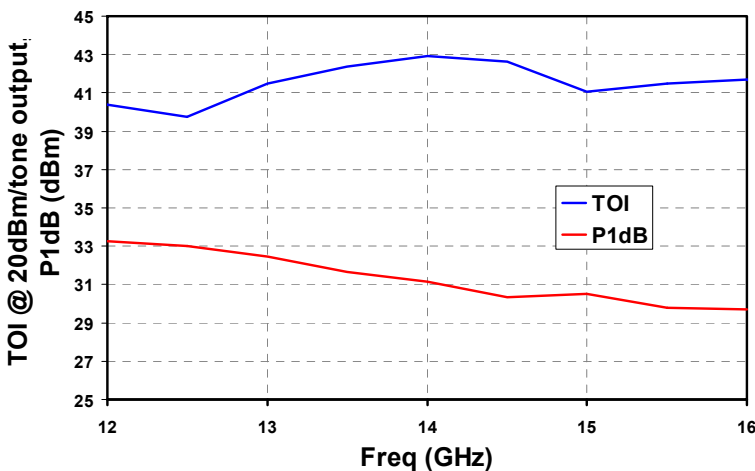

Datasheet subject to change without notice

**TABLE I
MAXIMUM RATINGS**

Symbol	Parameter <u>1/</u>	Value	Notes
V ⁺	Positive Supply Voltage	8 V	<u>2/</u>
V ⁻	Negative Supply Voltage Range	-5V to 0V	
I ⁺	Positive Supply Current (under RF Drive)	1300 mA	<u>2/</u>
I _G	Gate Supply Current Range	-7 to 56 mA	
P _{IN}	Input Continuous Wave Power	23.2 dBm	<u>2/</u>
P _D	Power Dissipation	9.8 W	<u>2/ 3/</u>
T _{CH}	Operating Channel Temperature	200 °C	<u>3/ 4/ 5/</u>
	Mounting Temperature (30 Seconds)	320 °C	
T _{STG}	Storage Temperature	-65 to 150 °C	

- 1/ These ratings represent the maximum operable values for this device.
- 2/ Combinations of supply voltage, supply current, input power, and output power shall not exceed P_D.
- 3/ When operated at this bias condition with a base plate temperature of 70°C the median life is 2.3E4.
- 4/ These ratings apply to each individual FET.
- 5/ Junction operating temperature will directly affect the device median time to failure (T_m). For maximum life, it is recommended that junction temperatures be maintained at the lowest possible levels.

TABLE II
RF CHARACTERIZATION TABLE
 (T_A = 25°C, Nominal)
 (V_d = 6 V, I_d = 850mA ± 5%)

SYMBOL	PARAMETER	TEST CONDITION	LIMITS			UNITS
			MIN	TYP	MAX	
Gain	Small Signal Gain	F = 12-16		33		dB
IRL	Input Return Loss	F = 12-16		8		dB
ORL	Output Return Loss	F = 12-16		12		dB
PWR	Output Power @ Pin = +5 dBm	F = 12-16		31		dBm

Note: Table II Lists the RF Characteristics of typical devices as determined by fixtured measurements.

**TABLE III
THERMAL INFORMATION**

PARAMETER	TEST CONDITION	T _{CH} (°C)	θ _{JC} (°C/W)	T _m (HRS)
θ _{JC} Thermal Resistance (Channel to Backside)	V _D = 6 V I _D = 850 mA P _D = 5.1 W	138	13.33	2.9 E+6
θ _{JC} Thermal Resistance (Channel to Backside)	V _d = 6V I _d = 1200 mA (under drive) P _{diss} = 6 W P _{out} = 1.2 W (RF)	150	13.33	1.0 E+6

Note: Assumes eutectic attach using 1.5mil 80/20 AuSn mounted to a 20mil CuMo carrier at 70°C baseplate temperature. Worst case condition with no RF applied, 100% of DC power is dissipated.

Median Lifetime (T_m) vs. Channel Temperature

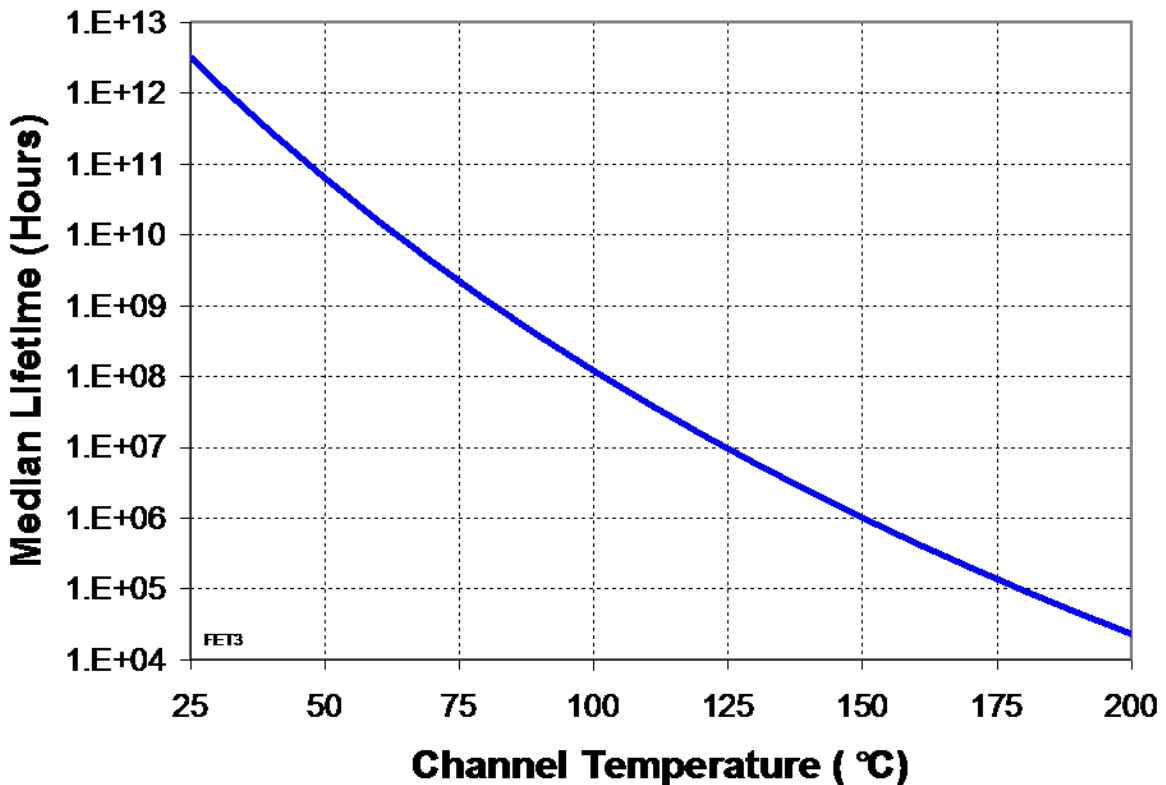

Typical Fixtured Performance

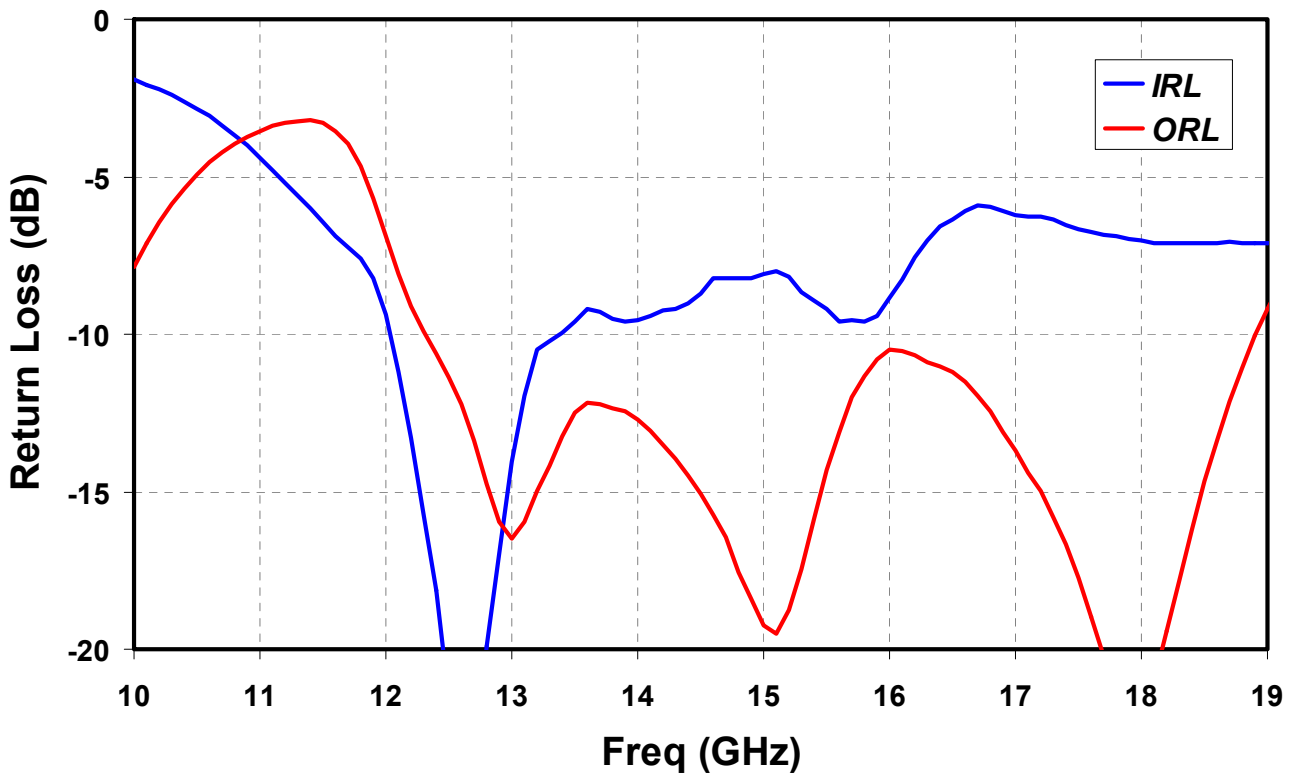
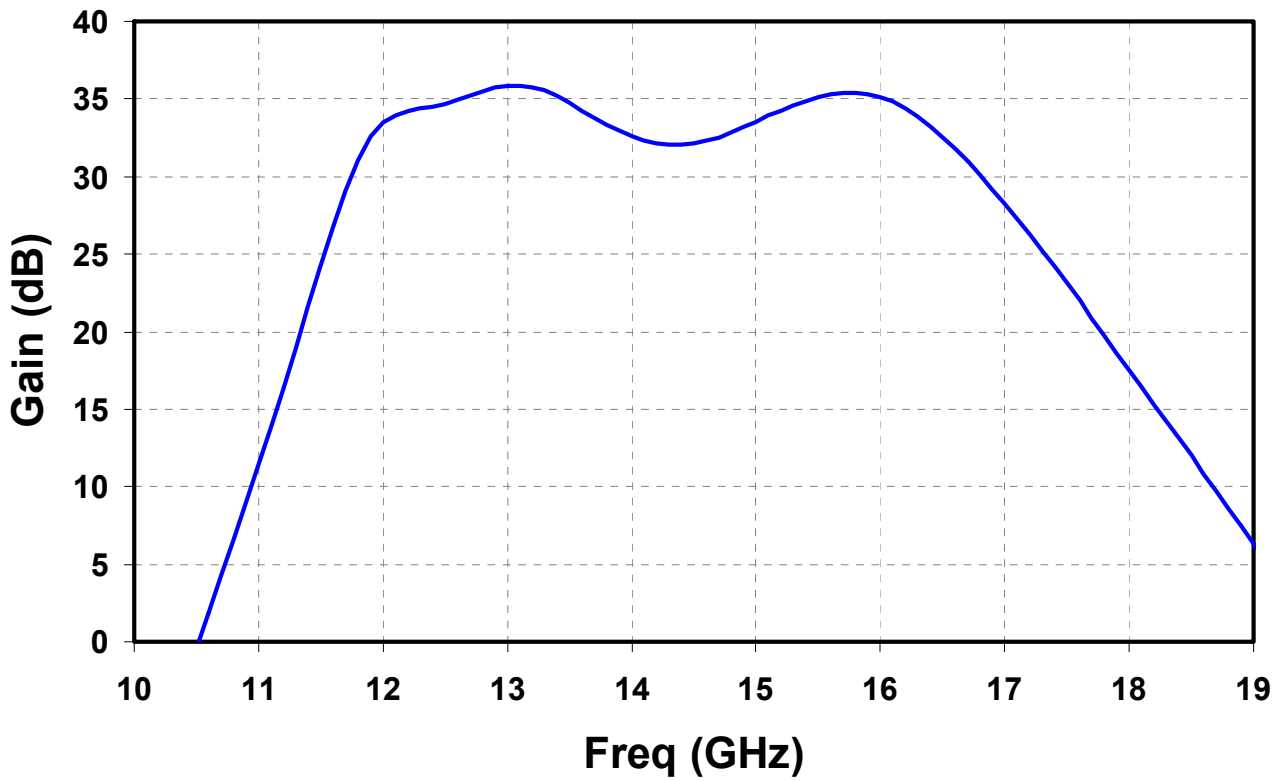

Typical Fixtured Performance

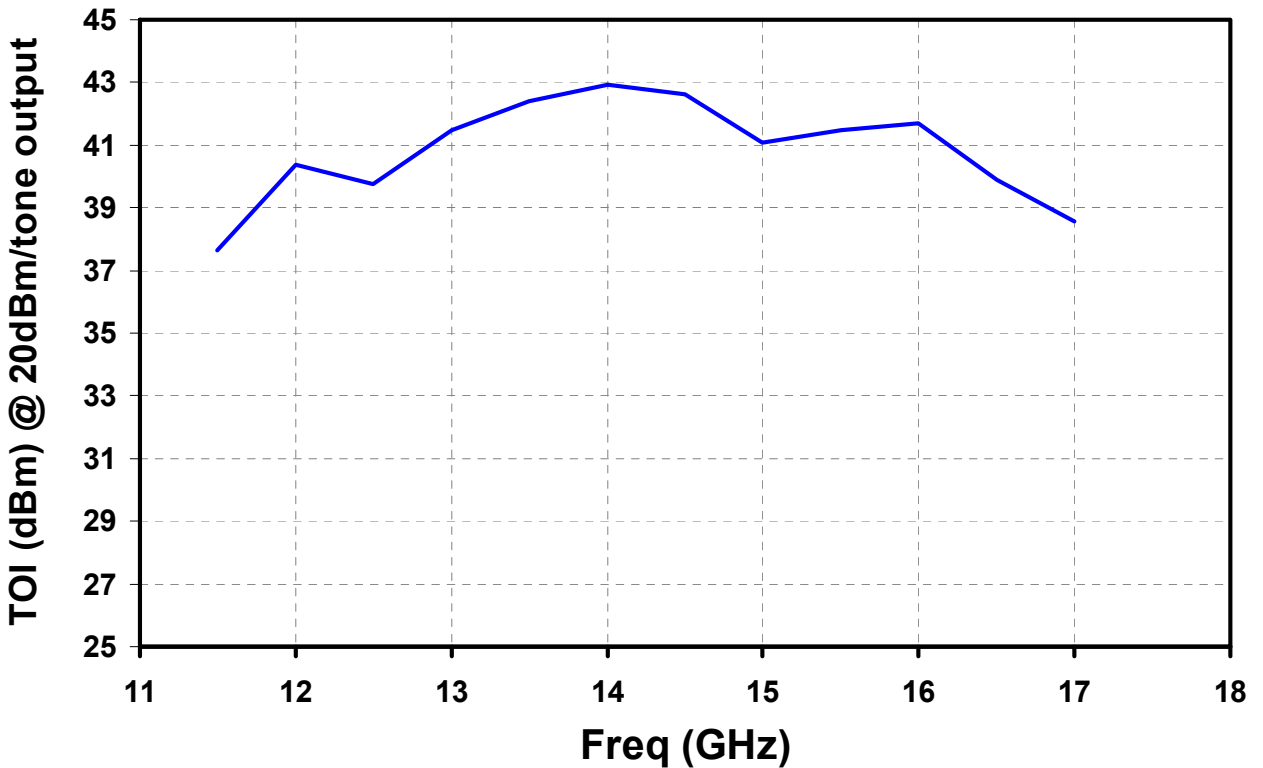
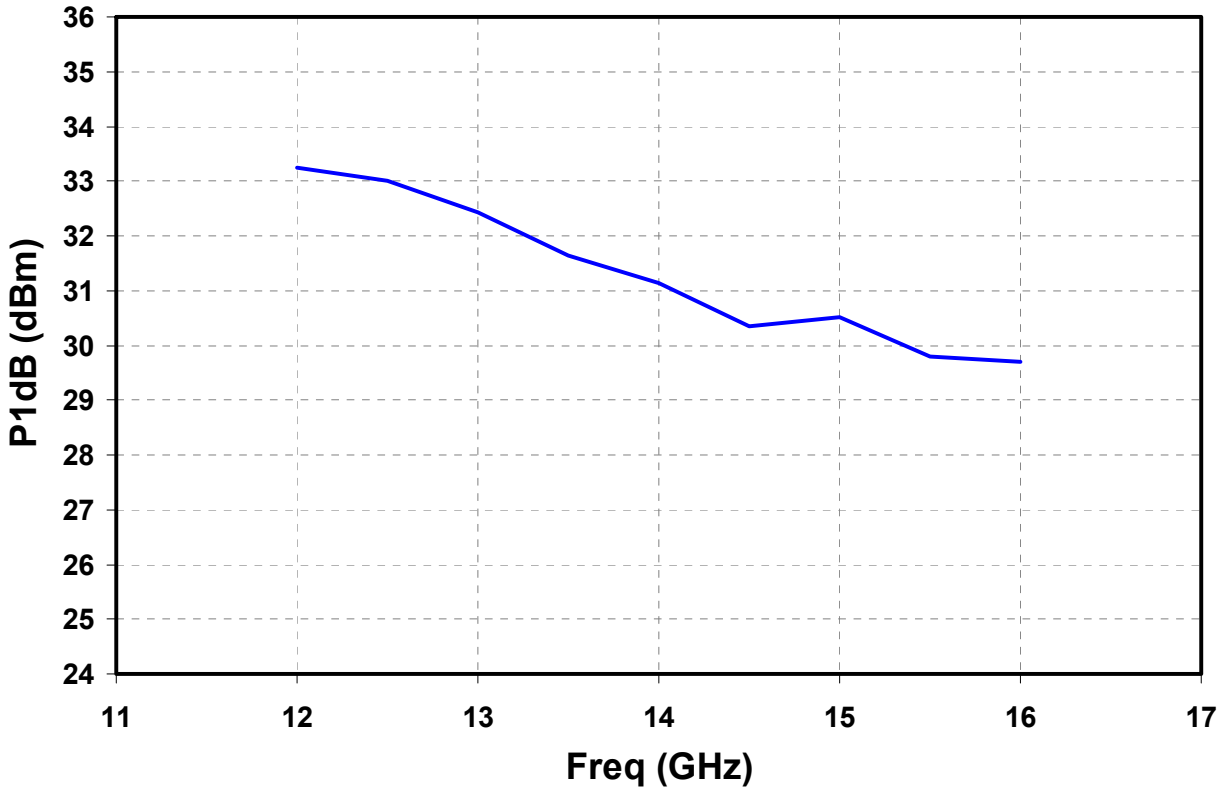

Typical Fixtured Performance

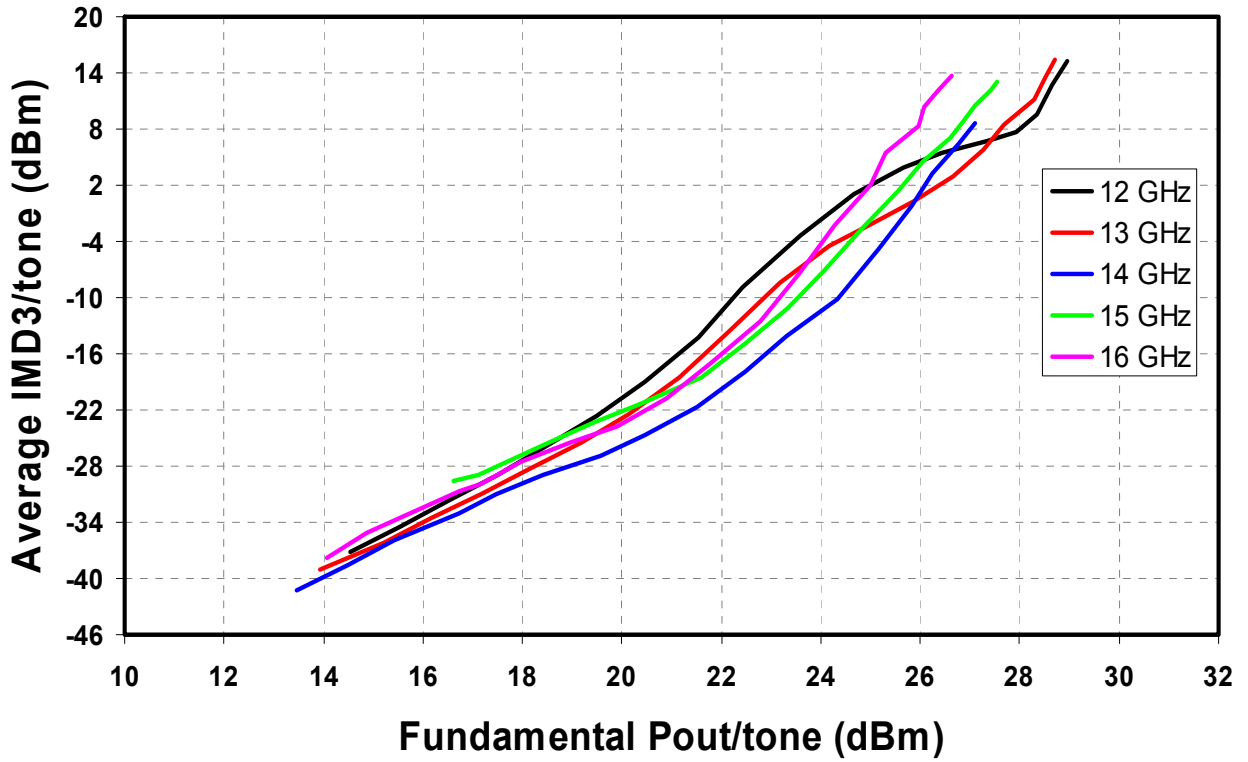

Mechanical Drawing

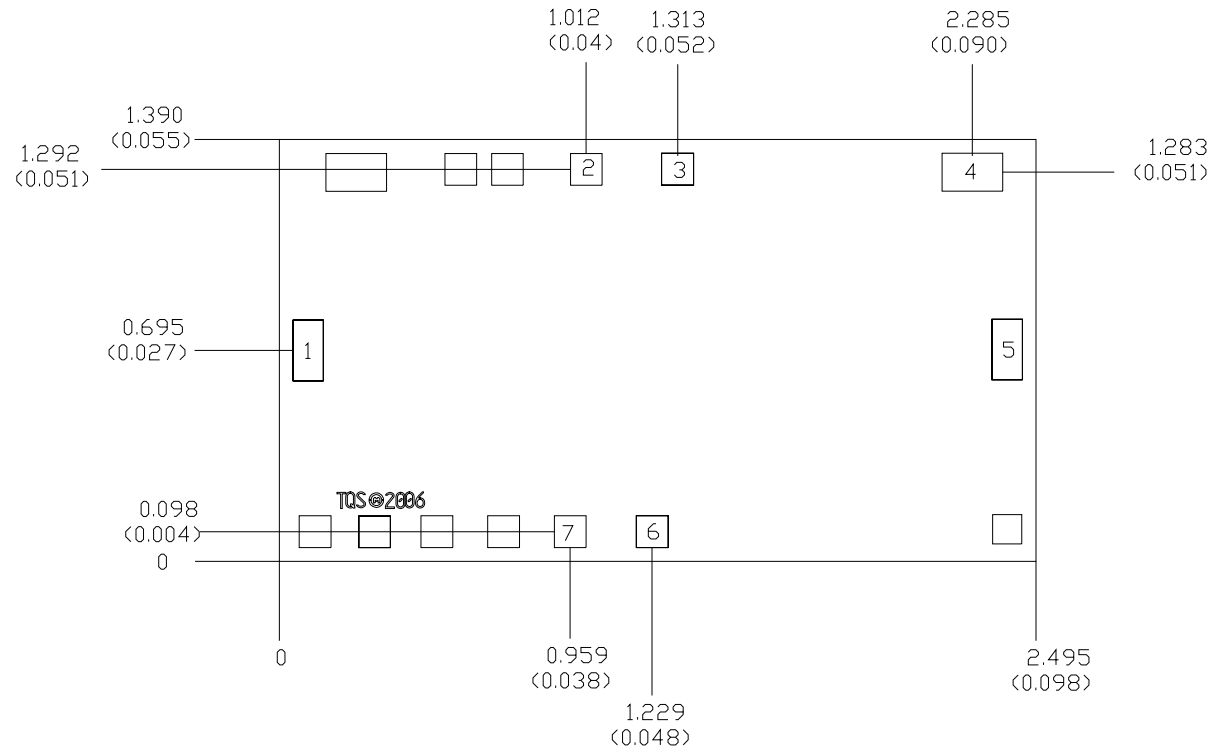

Units: millimeters (inches)

Thickness: 0.1016 (0.004) (reference only)

Chip edge to bond pad dimensions are shown to center of Bond pads.

Chip size tolerance: +/- 0.0508 (0.002)

RF Ground through Backside

Bond Pad #1	(RF Input)	0.100 × 0.200	(0.004 × 0.008)
Bond Pad #2	(Bypass)	0.100 × 0.100	(0.004 × 0.004)
Bond Pad #3	(Vd1)	0.100 × 0.100	(0.004 × 0.004)
Bond Pad #4	(Vd2)	0.200 × 0.125	(0.008 × 0.005)
Bond Pad #5	(RF Output)	0.100 × 0.200	(0.004 × 0.008)
Bond Pad #6	(Vg2)	0.100 × 0.100	(0.004 × 0.004)
Bond Pad #7	(Vg1)	0.100 × 0.100	(0.004 × 0.004)

Chip Assembly & Bonding Diagram

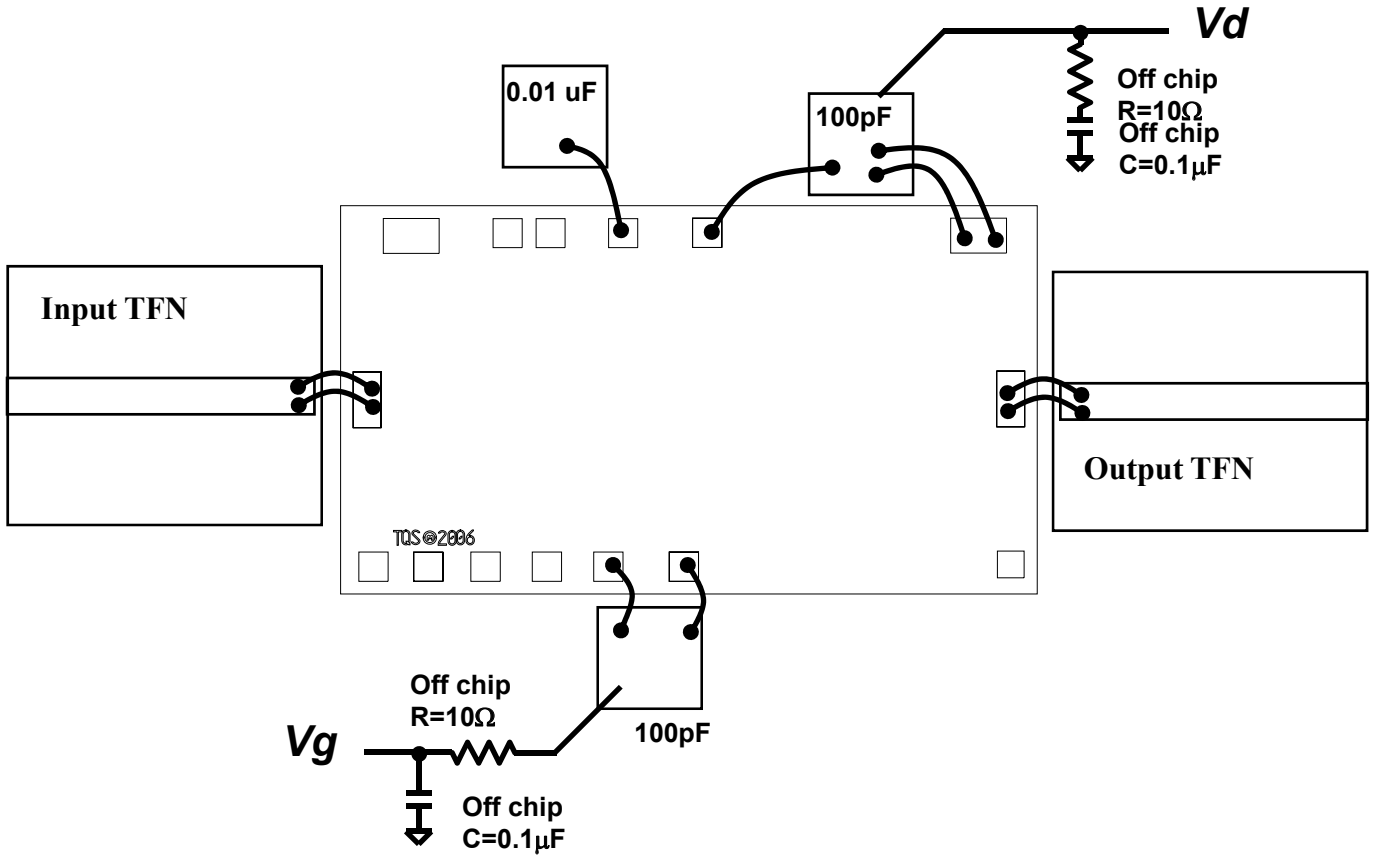

Typical $V_g \approx -0.5 V$

GaAs MMIC devices are susceptible to damage from Electrostatic Discharge. Proper precautions should be observed during handling, assembly and test.

Assembly Process Notes

Reflow process assembly notes:

- Use AuSn (80/20) solder with limited exposure to temperatures at or above 300°C. (30 seconds maximum)
- An alloy station or conveyor furnace with reducing atmosphere should be used.
- No fluxes should be utilized.
- Coefficient of thermal expansion matching is critical for long-term reliability.
- Devices must be stored in a dry nitrogen atmosphere.

Component placement and adhesive attachment assembly notes:

- Vacuum pencils and/or vacuum collets are the preferred method of pick up.
- Air bridges must be avoided during placement.
- The force impact is critical during auto placement.
- Organic attachment can be used in low-power applications.
- Curing should be done in a convection oven; proper exhaust is a safety concern.
- Microwave or radiant curing should not be used because of differential heating.
- Coefficient of thermal expansion matching is critical.

Interconnect process assembly notes:

- Thermosonic ball bonding is the preferred interconnect technique.
- Force, time, and ultrasonics are critical parameters.
- Aluminum wire should not be used.
- Discrete FET devices with small pad sizes should be bonded with 0.0007-inch wire.
- Maximum stage temperature is 200°C.

GaAs MMIC devices are susceptible to damage from Electrostatic Discharge. Proper precautions should be observed during handling, assembly and test.