

TGA8300-SCC

Gain Block Amplifier

8300

- **2 to 18 GHz Frequency Range**
- **20-dBm Typical Output Power at 1-dB Gain Compression**
- **7.5-dB Typical Gain**
- **Input/Output SWR 1.5:1**
- **On-Chip Blocking Capacitor Allows Easy Cascading**
- **2,362 x 1,625 x 0,152 mm (0.093 x 0.064 x 0.006 in.)**

PHOTO ENLARGEMENT

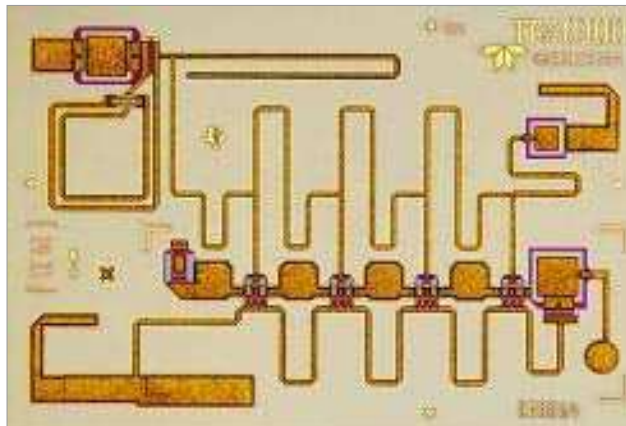

DESCRIPTION

The TriQuint TGA8300 -SCC is a GaAs monolithic distributed amplifier designed for use as a multioctave general -purpose gain block. Four 189 - μ m gate width FETs provide 7.5 dB nominal gain and 5.5 -dB noise figure from 2 to 18 -GHz. Typical power output is 20 -dBm at 1-dB gain compression. Typical input and output SWRs are 1.5:1. Ground is provided to the circuitry through vias to the backside metallization.

The TGA8300 -SCC is supplied in chip form and is engineered for high -volume automated assembly. All metal surfaces are gold plated to be compatible with thermocompression and thermosonic wire -bonding processes.

**TYPICAL
SMALL-SIGNAL
POWER GAIN**

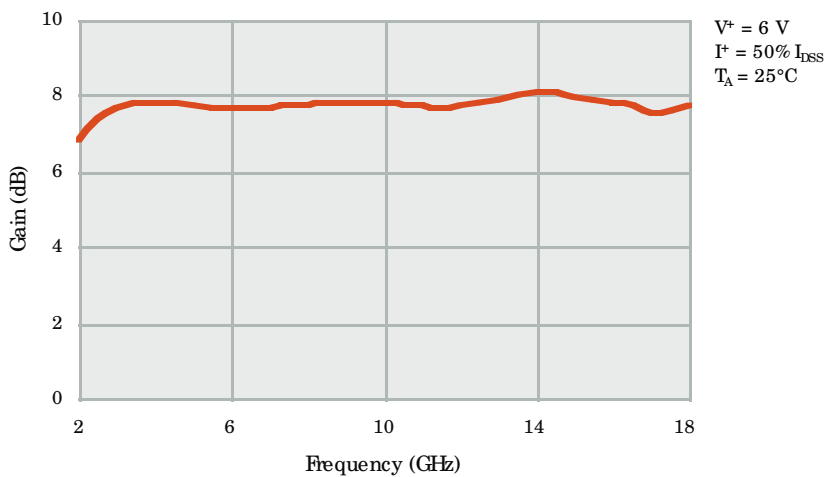

**TYPICAL
NOISE FIGURE**

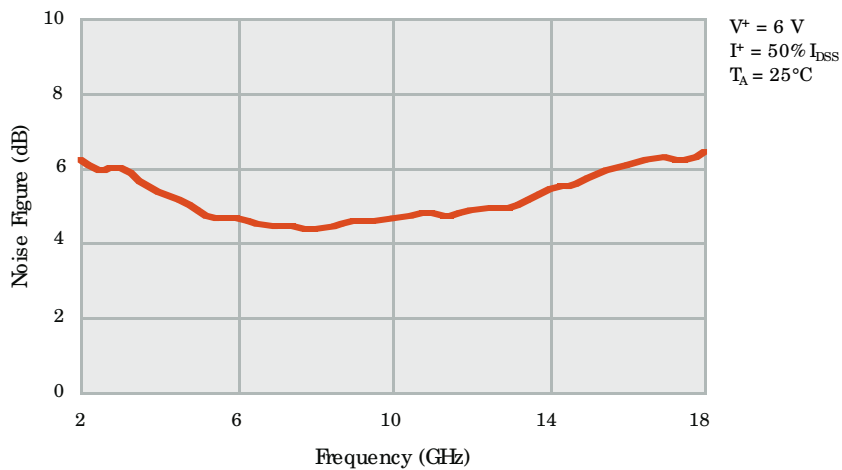

**TYPICAL
OUTPUT POWER
 P_{1dB}**

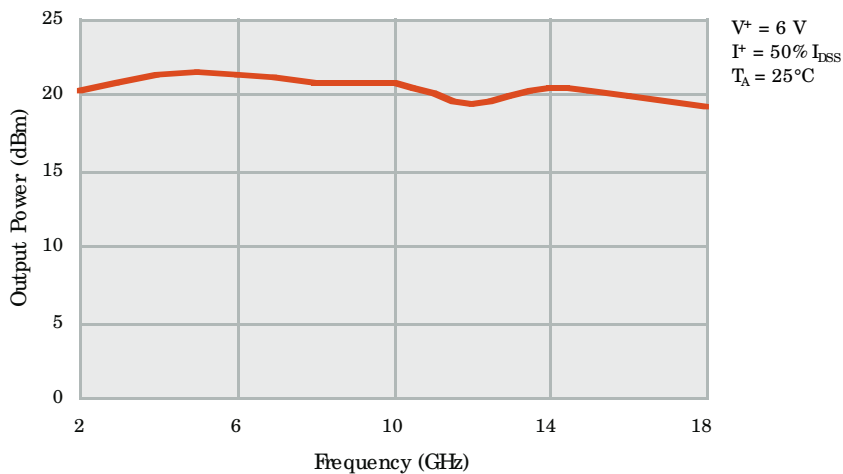

**TYPICAL
RETURN LOSS**

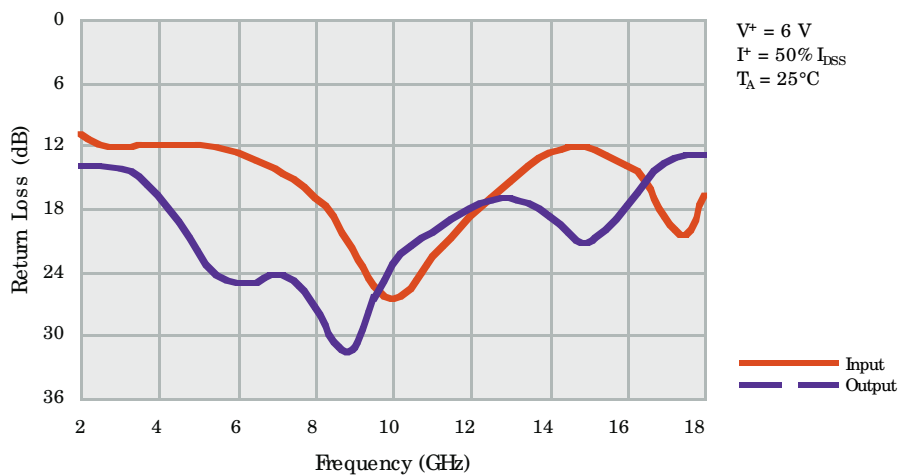

**ABSOLUTE
MAXIMUM RATINGS**

Positive supply voltage, V^+	8 V
Negative supply voltage range, V^-	0 V to -5 V
Power dissipation, P_D at (or below) 25 C base-plate temperature*	1.8 W
Operating channel temperature, T_{CH}^{**}	150 C
Mounting temperature (30 sec), T_M	320 C
Storage temperature range, T_{STG}	-65 to 150 C

Ratings over operating channel temperature range, T_{CH} (unless otherwise noted)

Stresses beyond those listed under “Absolute Maximum Ratings” may cause permanent damage to the device. These are stress ratings only, and functional operation of the device at these or any other conditions beyond those indicated under “RF Characteristics” is not implied. Exposure to absolute maximum rated conditions for extended periods may affect device reliability.

* For operation above 25 C base-plate temperature, derate linearly at the rate of 3.8 mW/ C.

**Operating channel temperature directly affects the device MTTF. For maximum life, it is recommended that channel temperature be maintained at the lowest possible level.

TYPICAL S-PARAMETERS

Frequency (GHz)	S ₁₁		S ₂₁		S ₁₂		S ₂₂		GAIN (dB)
	MAG	ANG (°)	MAG	ANG (°)	MAG	ANG (°)	MAG	ANG (°)	
1.0	0.40	4	2.32	-146	0.017	-163	0.52	-110	7.3
1.5	0.40	-151	2.00	167	0.015	97	0.32	-172	6.0
2.0	0.28	180	2.20	155	0.017	91	0.20	109	6.8
2.5	0.26	167	2.34	137	0.022	75	0.20	56	7.4
3.0	0.25	158	2.41	121	0.027	59	0.20	27	7.6
3.5	0.25	151	2.45	105	0.031	40	0.18	10	7.8
4.0	0.25	143	2.46	89	0.033	25	0.15	-2	7.8
4.5	0.25	137	2.45	74	0.037	12	0.11	-10	7.8
5.0	0.25	132	2.44	60	0.040	-3	0.08	-13	7.7
5.5	0.24	127	2.42	46	0.043	-17	0.06	-11	7.7
6.0	0.23	122	2.42	32	0.045	-31	0.06	-9	7.7
6.5	0.21	116	2.41	19	0.048	-45	0.06	-10	7.6
7.0	0.19	112	2.43	5	0.051	-58	0.06	-16	7.7
7.5	0.17	106	2.45	-8	0.054	-72	0.06	-30	7.8
8.0	0.14	101	2.45	-22	0.058	-86	0.04	-44	7.8
8.5	0.11	97	2.45	-36	0.062	-100	0.03	-81	7.8
9.0	0.08	95	2.46	-50	0.066	-113	0.03	-143	7.8
9.5	0.05	105	2.47	-64	0.070	-126	0.05	174	7.8
10.0	0.05	130	2.46	-78	0.075	-139	0.07	148	7.8
10.5	0.05	148	2.45	-92	0.079	-152	0.08	126	7.8
11.0	0.07	146	2.44	-106	0.082	-165	0.10	105	7.7
11.5	0.09	134	2.42	-120	0.086	-177	0.11	82	7.7
12.0	0.11	117	2.43	-134	0.091	171	0.13	60	7.7
12.5	0.14	97	2.46	-148	0.095	159	0.14	38	7.8
13.0	0.17	76	2.49	-162	0.100	147	0.14	17	7.9
13.5	0.20	58	2.51	-177	0.104	135	0.13	-4	8.0
14.0	0.23	42	2.54	-168	0.109	121	0.12	-32	8.1
14.5	0.25	27	2.54	-152	0.113	106	0.10	-66	8.1
15.0	0.25	15	2.51	-136	0.114	91	0.09	-110	8.0
15.5	0.23	6	2.47	-121	0.115	77	0.10	-158	7.9
16.0	0.20	-1	2.46	-105	0.115	61	0.13	165	7.8
16.5	0.17	-3	2.44	-90	0.116	46	0.17	134	7.7
17.0	0.12	2	2.39	-74	0.116	-3	0.21	116	7.6
17.5	0.09	32	2.40	-58	0.119	15	0.23	98	7.6
18.0	0.15	60	2.44	-42	0.125	-0	0.23	80	7.7
18.5	0.22	59	2.53	-24	0.136	-16	0.19	66	8.1
19.0	0.30	44	2.64	4	0.150	-36	0.12	65	8.4
19.5	0.28	21	2.62	-19	0.155	-59	0.11	100	8.4
20.0	0.21	-8	2.44	-42	0.151	-80	0.19	107	7.7

$$V^+ = 6 \text{ V}, I^+ = 50\% I_{\text{DSS}}, T_A = 25^\circ\text{C}$$

Reference planes for S - parameter data include bond wires as specified in the "Recommended Assembly Diagram."

RF CHARACTERISTICS

PARAMETER		TEST CONDITIONS	TYP	UNIT
G_P	Small-signal power gain	$f = 2$ to 18 GHz	7.5	dB
SWR(in)	Input standing wave ratio	$f = 2$ to 18 GHz	1.5:1	-
SWR(out)	Output standing wave ratio	$f = 2$ to 18 GHz	1.4:1	-
P_{1dB}	Output power at 1-dB gain compression	$f = 2$ to 18 GHz	20	dBm
NF	Noise figure	$f = 2$ to 18 GHz	5.5	dB
IP_3	Output third-order intercept point	$f = 8$ GHz	32	dBm
		$f = 12$ GHz	28	
		$f = 18$ GHz	27	

$V^+ = 6$ V, $I^+ = 50\% I_{DSS}$, $T_A = 25^\circ\text{C}$

DC CHARACTERISTICS

PARAMETER	TEST CONDITIONS	MIN	MAX	UNIT	
I_{DSS}	Total zero-gate-voltage drain current at saturation	$V_{DS} = 0.5$ V to 3.5 V, $V_{GS} = 0$	130	300	mA

$T_A = 25^\circ\text{C}$

V_{DS} for I_{DSS} is the drain voltage between 0.5 V and 3.5 V at which drain current is highest at DC autoprobe.

THERMAL INFORMATION

PARAMETER	TEST CONDITIONS	NOM	UNIT	
R_{JC}	Thermal resistance, channel-to-backside	$V^+ = 6$ V, $I^+ = 50\% I_{DSS}$	45	$^\circ\text{C/W}$

EQUIVALENT SCHEMATIC

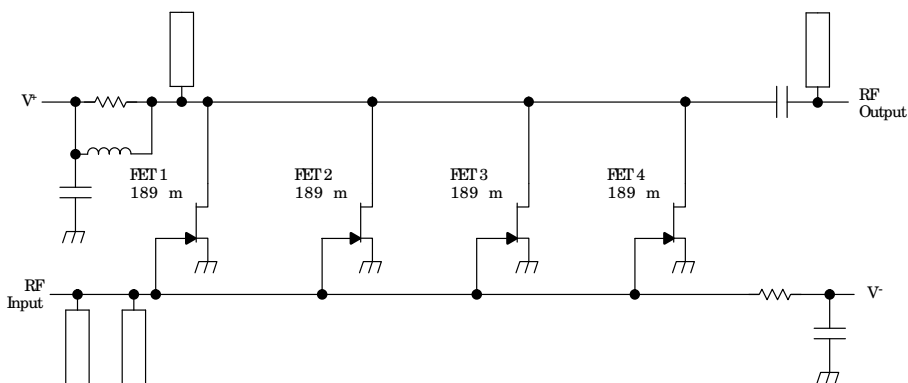

RECOMMENDED TEST CONFIGURATION

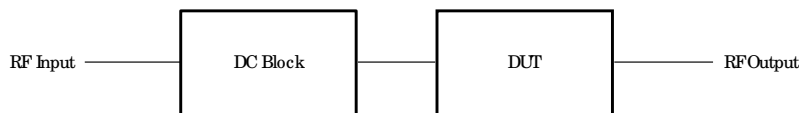

TYPICAL BIAS NETWORK

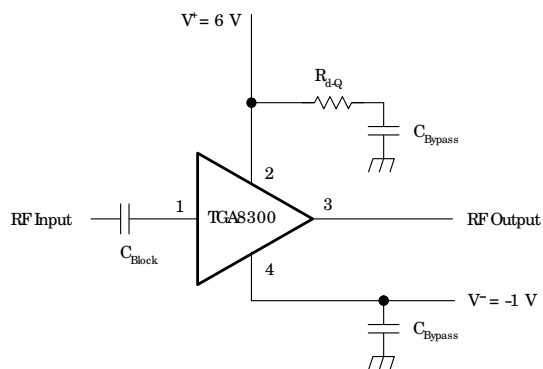

RECOMMENDED ASSEMBLY DIAGRAM

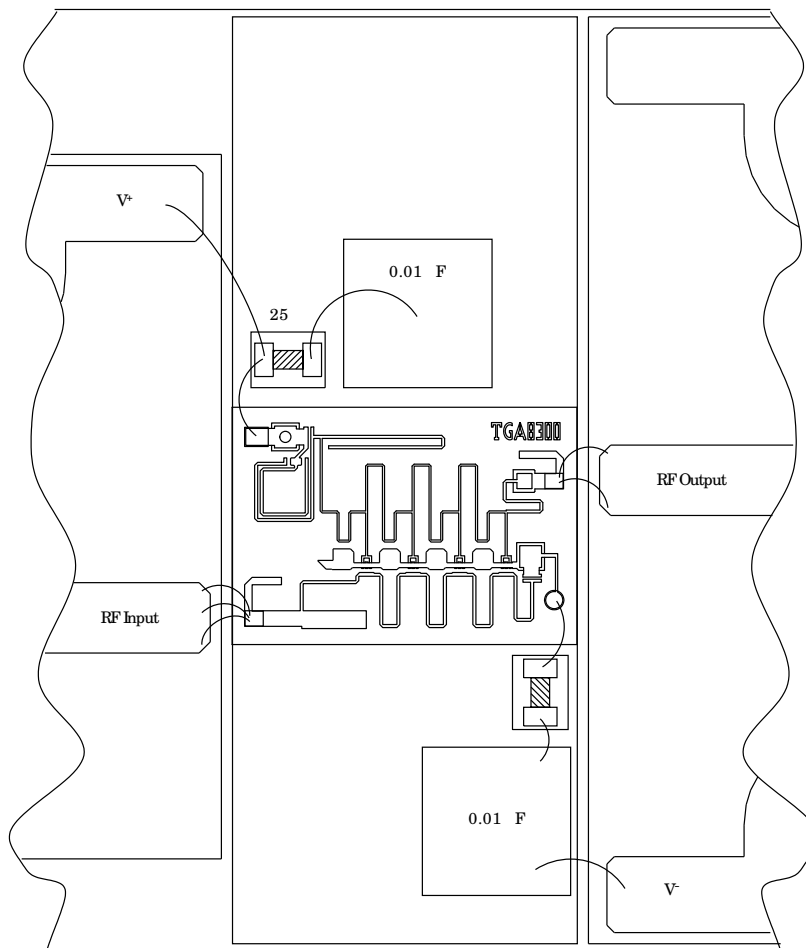

RF connections: Bond using three 1-mil diameter, 20 to 30-mil-length gold bond wires at RF input and two 1-mil diameter, 20 to 30-mil-length gold bond wires at RF output for optimum RF performance.

Close placement of external components is essential to stability.

MECHANICAL DRAWING

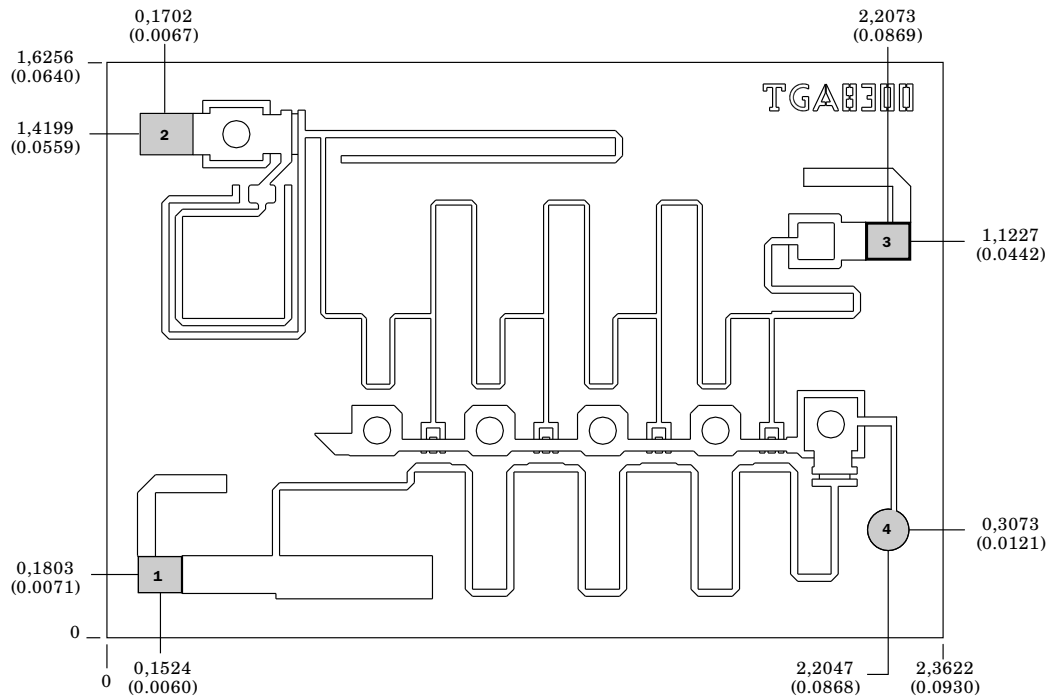

Units: millimeters (inches)

Thickness: 0,1524 (0.0060) (reference only)

Chip edge to bond pad dimensions are shown to center of bond pad.

Chip size tolerance: $\pm 0,0508$ (0.0020)

Bond pad #1 (RF Input):	0,1270 x 0,1016 (0.0050 x 0.0040)
Bond pad #2 (V ⁺):	0,1575 x 0,1245 (0.0062 x 0.0049)
Bond pad #3 (RF Output):	0,1321 x 0,1016 (0.0052 x 0.0040)
Bond pad #4 (V ⁻):	0,0635 (0.0025) (radius)