

# TAT7457

## CATV 75 $\Omega$ pHEMT Adjustable Gain RF Amplifier



### Applications

- Single-ended and Push-pull Optical Receivers
- Low-noise Drop Amplifiers
- Distribution Amplifiers
- Multi-Dwelling Units
- Single-ended Gain Block



SOT-89 package

### Product Features

- Gain, return loss and bias externally adjustable
- On-chip active bias for consistent bias current and repeatable performance
- DC – 2000 MHz bandwidth
- Low noise: typical NF < 2 dB to 1000MHz
- Flexible 5 V to 8 V biasing
- $I_{DD}(5V) = 120$  mA typical in application circuit
- 19 dB typical gain in application circuit
- +40 dBm typical OIP3
- +61 dBm typical OIP2
- +21 dBm typical P1dB
- Low distortion: CSO -66 dBc, CTB -78 dBc (10 dBmV/ch at input, 80 ch NTSC flat)
- pHEMT device technology
- SOT-89 package

### Functional Block Diagram

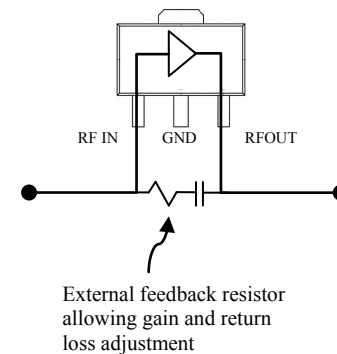

### General Description

The TAT7457 is a low cost RF amplifier designed for applications from DC to 2000 MHz. The balance of low noise and distortion provides an ideal solution for a wide range of broadband amplifiers used in cable television applications such as optical receivers and low noise front ends.

The TAT7457 has features allowing a great deal of design-in flexibility. Gain and return loss are adjustable with an external feedback resistor. An internal bias circuit mitigates the effect of temperature and process variation and an external resistor may be used to adjust the bias current to optimize distortion or noise performance. There are no on-chip capacitors limiting the low freq response which extends down to DC.

The TAT7457 is fabricated using 6-inch GaAs pHEMT technology to optimize performance and cost. It provides excellent gain and return loss consistency inherent to the pHEMT process.

### Pin Configuration

Pin #	Symbol
1	RF IN
2	GND
3	RF OUT
4	GND PADDLE

### Ordering Information

Part No.	Description
TAT7457	75 $\Omega$ High linearity pHEMT amplifier (lead-free/RoHS compliant SOT-89 Pkg)
TAT7457-EB	Amplifier evaluation board

Standard T/R size = 1000 pieces on a 7" reel.

### Specifications

#### Absolute Maximum Ratings

Parameter	Rating
Storage Temperature	-65 to +150 °C
Device Voltage	+ 10 V
Thermal Resistance (jnc. to case) $\theta_{jc}$	38 °C/W

Operation of this device outside the parameter ranges given above may cause permanent damage.

#### Recommended Operating Conditions

Parameter	Min	Typ	Max	Units
$V_{cc}$	5		8	V
$I_{cc}$		120		mA
$T_J$ (for >10 <sup>6</sup> hours MTF)			150	°C

Electrical specifications are measured at specified test conditions. Specifications are not guaranteed over all recommended operating conditions.

#### Electrical Specifications

Test conditions unless otherwise noted: 25°C case temp, +5V Vsupply, DC to 1200 MHz, 1 k $\Omega$  feedback resistor

Parameter	Conditions	Min	Typical	Max	Units
Operational Frequency Range		DC		1200	MHz
Gain			19		dB
Gain Flatness			+/- 0.7		dB
Noise Figure at 1 GHz			2.0		dB
Input Return Loss			18		dB
Output Return Loss			18		dB
Output P1dB			+21		dBm
Output IP3	See Note 1.		+40		dBm
Output IP2	See Note 1.		+61		dBm
CSO	See Note 2.		-66		dBc
CTB	See Note 2.		-78		dBc
Idd			120		mA
Thermal Resistance (jnc. to case) $\theta_{jc}$			38		°C/W

Notes:

1. At -17 dBm/tone at input.
2. 10 dBmV/ch at input, 80 ch flat NTSC
3. Electrical specifications are measured at specified test conditions.
4. Specifications are not guaranteed over all recommended operating conditions.

# TAT7457

## CATV 75 $\Omega$ pHEMT Adjustable Gain RF Amplifier



### Reference Design DC-1200 MHz

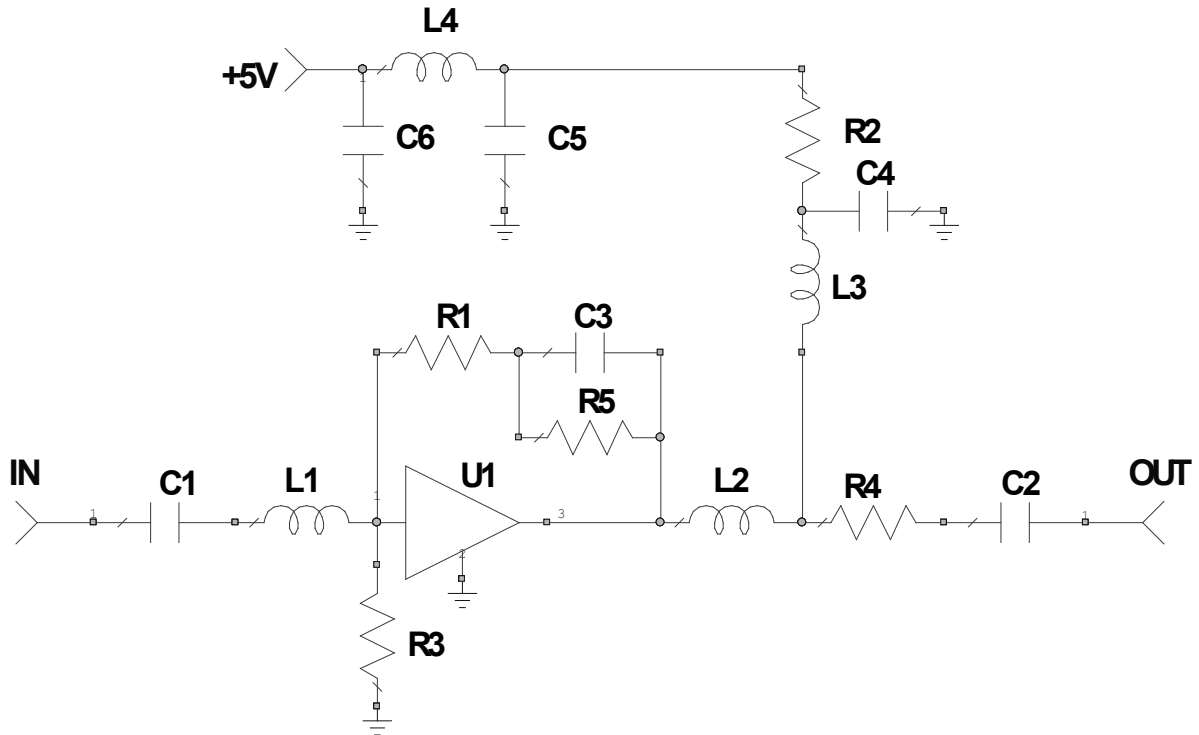

Notes:

1. See PC Board Layout, page 9 for more information

### Bill of Material

Ref Des	Value	Description	Manufacturer	Part Number
U1		Amplifier, SOT-89	TriQuint	TAT7457
R1	1 k $\Omega$	Thick Film Res., 0402, 1%	various	
R2	0 $\Omega$	Thick Film Res., 1206	various	
R3	N/L			
R4	0 $\Omega$	Thick Film Res., 0402	various	
R5	75 k $\Omega$	Thick Film Res., 0402, 1%	various	
C1, C2	0.01 uF	Ceramic Cap, 0603, X7R, 16V, 10%	various	
C3, C4	0.01 uF	Ceramic Cap, 0402, X7R, 16V, 10%	various	
C5, C6	0.1 uF	Ceramic Cap, 0603, X7R, 16V, 10%	various	
L1, L2	4.7 nH	Ceramic Wire-Wound Ind, 0402, 5%	various	
L3	880 nH	Ferrite Ind., Vertical Wire-Wound, 1206, 10%	various	
L4	910 nH	Ferrite Ind., Vertical Wire-Wound, 1008, 10%	various	

# TAT7457

## CATV 75 $\Omega$ pHEMT Adjustable Gain RF Amplifier



### Application Board Typical Performance For DC - 1200 MHz, 5 V Application

Case temperature noted on graphs. Reference design used.  $V_{supply} = 5\text{ V}$ ,  $I_{dd} = 120\text{ mA}$ .

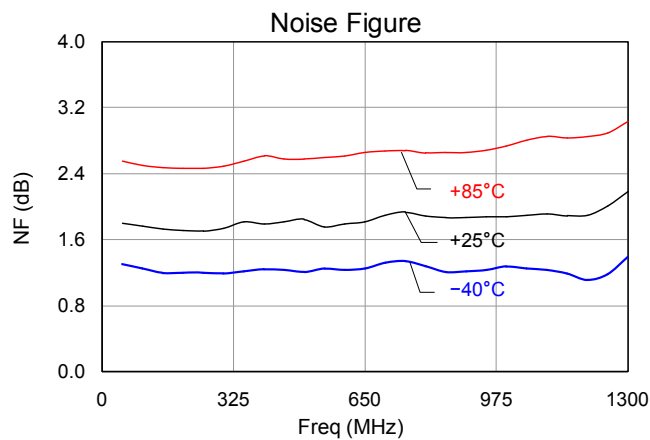
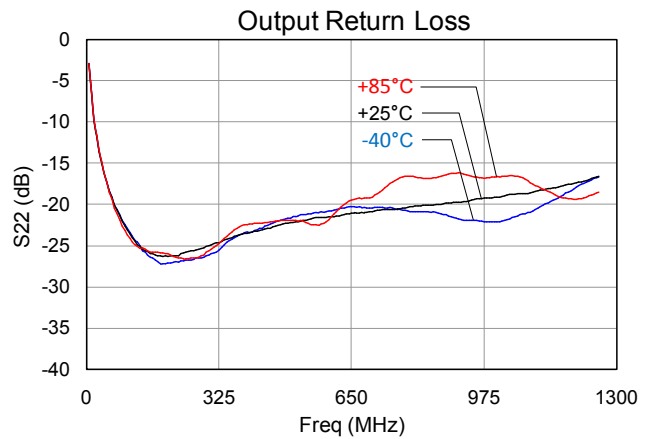
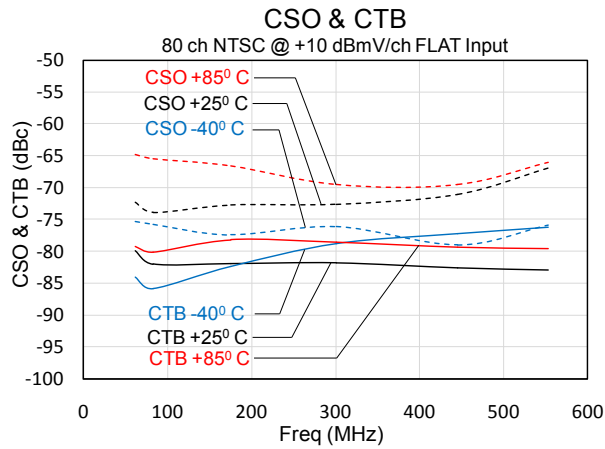
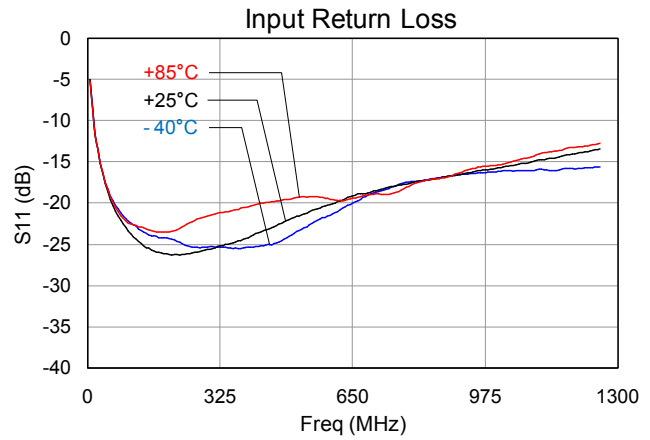
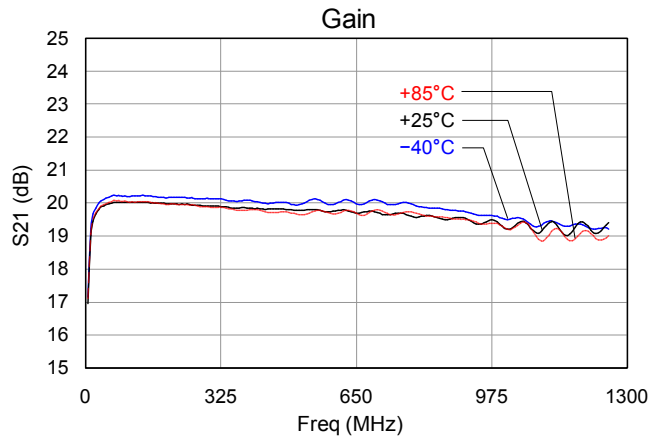

# TAT7457

## CATV 75 $\Omega$ pHEMT Adjustable Gain RF Amplifier



### Application Board Typical Performance For DC - 1200 MHz, 8 V Application

Case temperature noted on graphs. Reference design used.  $V_{supply} = 8\text{ V}$ ;  $I_{dd} = 140\text{ mA}$  at  $25^\circ\text{C}$ .  $I_{dd}$  adjusted with an external supply, similar to adjusting R3 and R5. Contact [sjcapplications.engineering@tqs.com](mailto:sjcapplications.engineering@tqs.com) for more information.

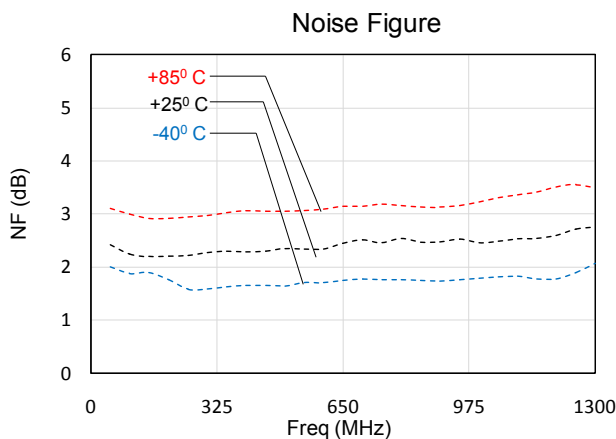
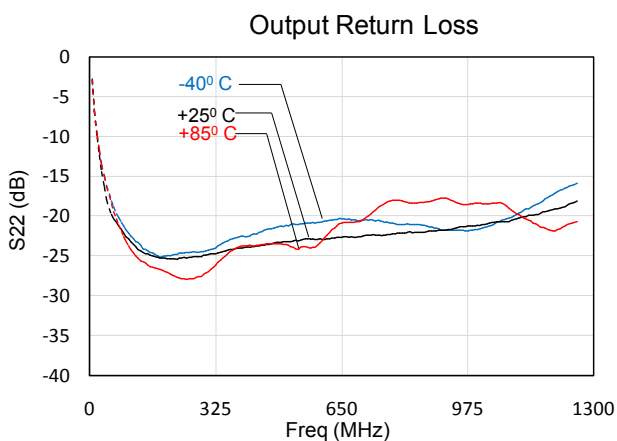
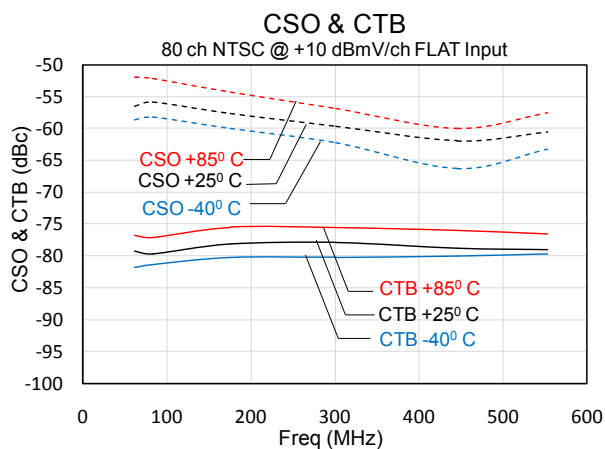
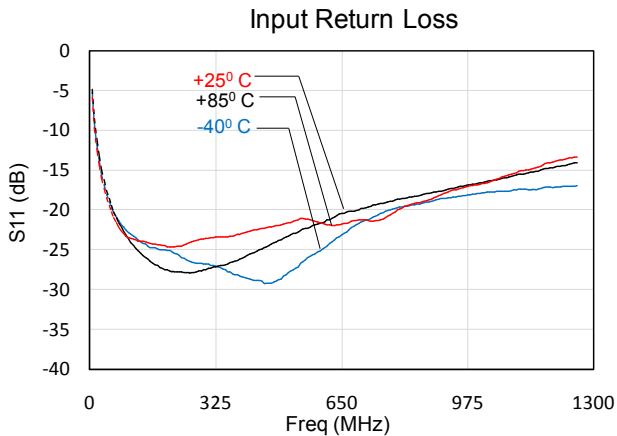
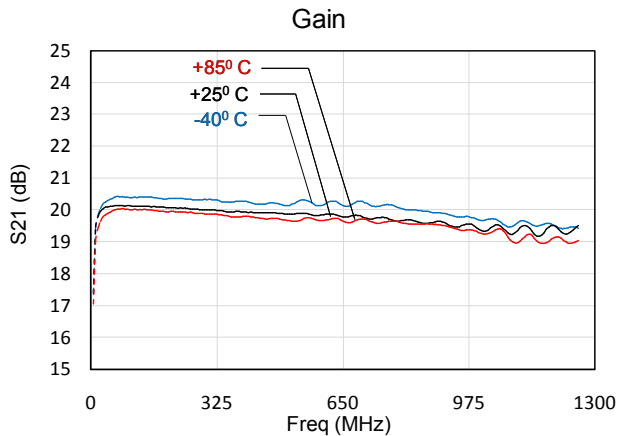

# TAT7457

## CATV 75 $\Omega$ pHEMT Adjustable Gain RF Amplifier



### Reference Design 2.0 GHz Satellite

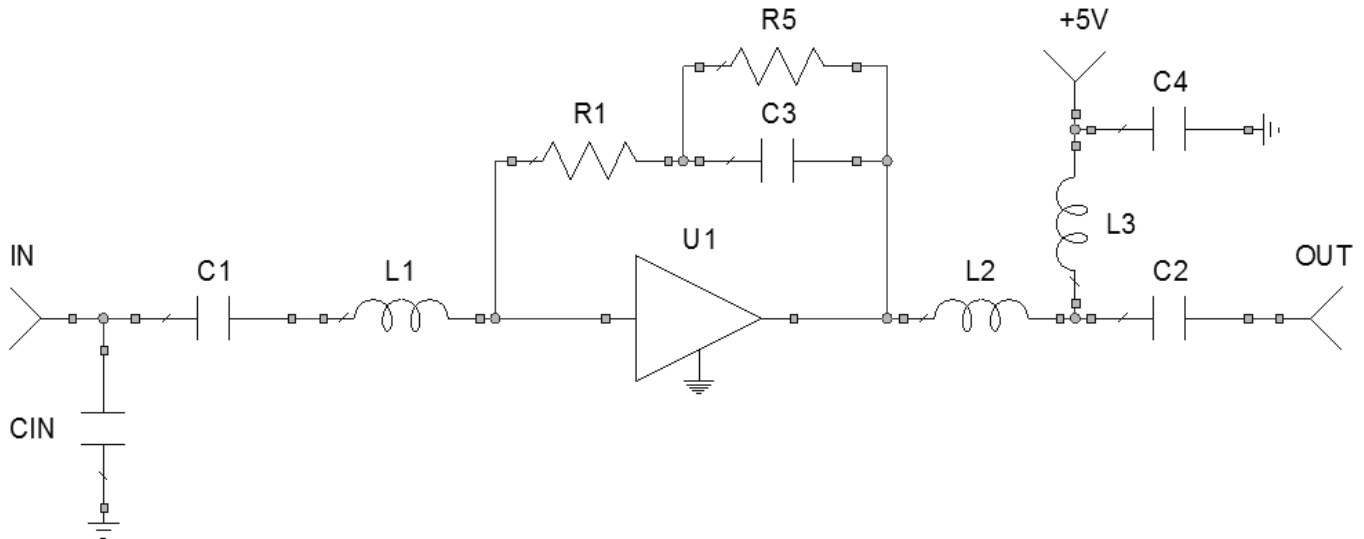

Notes:

2. See PC Board Layout, page 9 for more information

### Bill of Material

Ref Des	Value	Description	Manufacturer	Part Number
U1		Amplifier, SOT-89	TriQuint	TAT7457
R1	750 $\Omega$	Thick Film Res., 0402, 1%	various	
R5	75 k $\Omega$	Thick Film Res., 0402, 1%	various	
C1, C2	0.01 $\mu$ F	Ceramic Cap, 0603, X7R, 16V, 10%	various	
C3	560 pF	Ceramic Cap, 0402, X7R, 16V, 10%	various	
C4	0.01 $\mu$ F	Ceramic Cap, 0402, X7R, 16V, 10%	various	
CIN	0.5 pF	Ceramic Cap, 0603, $\pm$ .1 pF	various	
L1	2.7 nH	Ceramic Wire-Wound Ind, 0402, 5%	various	
L2	2.0 nH	Ceramic Wire-Wound Ind, 0402, 5%	various	
L3	880 $\mu$ H	Ferrite Ind., Vertical Wire-Wound, 1206, 10%	various	

# TAT7457

## CATV 75 $\Omega$ pHEMT Adjustable Gain RF Amplifier



### Application Board Typical Performance For Satellite Application

Reference design for 2.0 GHz Satellite used.  $V_{supply} = 5\text{ V}$ ,  $25\text{ }^\circ\text{C}$  ambient temperature.

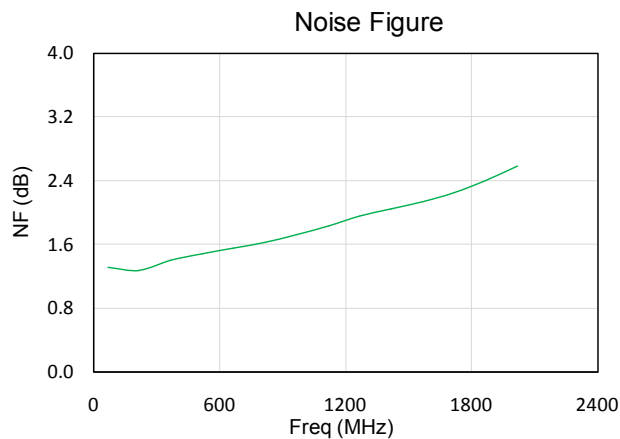
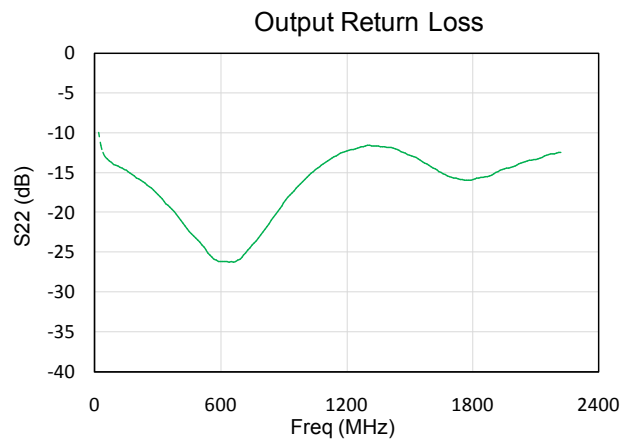
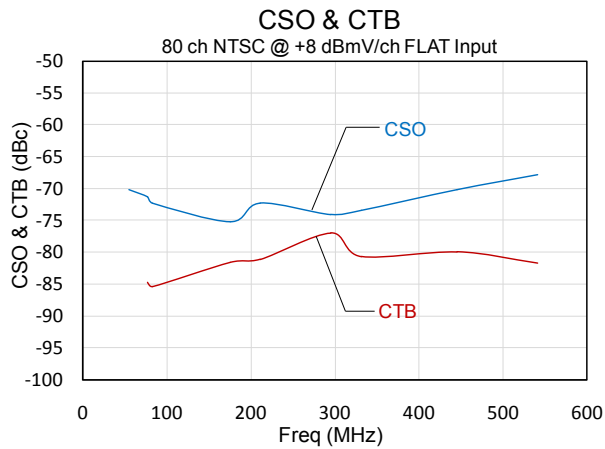
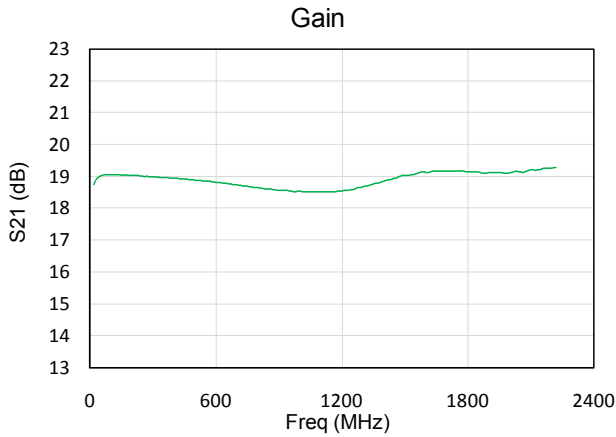

# TAT7457

## CATV 75 Ω pHEMT Adjustable Gain RF Amplifier



### Detailed Device Description

The TAT7457 was designed to be a low cost general purpose amplifier suitable for a wide range of applications.

The TAT7457 is a high gain cascode amplifier with no internal shunt feedback.

An on-chip biasing network sets the operating conditions for the FETs. This network stabilizes bias current against changes in temperature as well as against the normal process variations expected from wafer to wafer. Stabilized bias current will lead to more consistent RF performance.

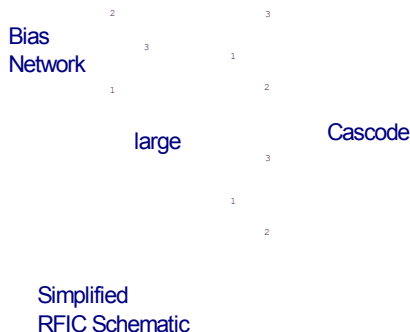

### APPLICATION SCHEMATIC



Customers may set the gain and return loss of their amplifier by selecting an appropriate external feedback resistor.

Reducing the value of the feedback resistor will reduce the gain and lower the input and output impedances.

Low noise TIA designers may set the value of feedback to a high value (>1k ohm) for best performance.

FIG. 1 Biasing through VNA Bias Tee

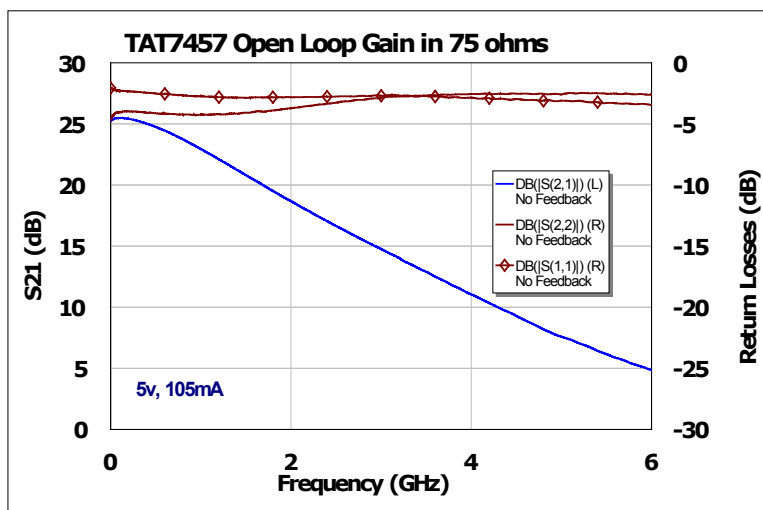

There are no on-chip capacitors that limit the low frequency response, enabling the TAT7457 frequency response to extend to DC. The open loop gain (no external feedback) and high frequency gain performance is shown in the plot to the left.



# TAT7457

## CATV 75 $\Omega$ pHEMT Adjustable Gain RF Amplifier



### Biassing Options for Improved Performance

Distortion and noise performance may be optimized with simple changes to the application circuit.

Noise performance may be improved by adding a large resistor R3 of approximately 20 k $\Omega$  to ground. This resistor will reduce the bias current and improve noise.

Best distortion occurs on a 6v supply; however for improved distortion on a 5v supply, bias current may be increased by adding a large pull up resistor R5 of approximately 75 k $\Omega$  in parallel with the feedback capacitor.

### Applications Information

#### PC Board Layout

Core is .062" FR-4,  $\epsilon_r = 4.7$ . Metal layers are 1-oz copper.

The pad pattern shown has been developed and tested for optimized assembly at TriQuint Semiconductor. The PCB land pattern has been developed to accommodate lead and package tolerances. Since surface mount processes vary from company to company, careful process development is recommended.

For further technical information, Refer to <http://www.triquint.com/TAT7457>

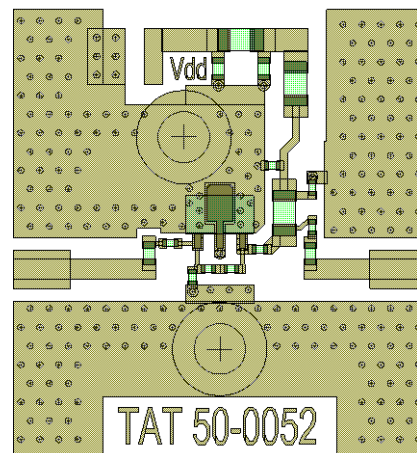

# TAT7457

## CATV 75 Ω pHEMT Adjustable Gain RF Amplifier



### Mechanical Information

#### Package Information and Dimensions

This package is lead-free/RoHS-compliant. The plating material on the leads is 100 % Matte Tin. It is compatible with both lead-free (maximum 260 °C reflow temperature) and lead (maximum 245 °C reflow temperature) soldering processes.

The TAT7457 will be marked with a “TAT7457” designator and an alphanumeric lot code.

SYMBOL	MIN	NOM	MAX
A - Thickness	1.40	1.50	1.60
C - Lead thickness	0.35		0.43
D - Body width	4.40		4.60
E1 - Body length	2.30		2.60
E - Total length	3.64		4.25
e - Lead spacing	1.40	1.50	1.60
e1 - Dual lead spacing	2.90	3.00	3.10
b - Outer lead width	0.35		0.48
b1 - Center lead width	0.40		0.56
L - Lead length	0.74		1.20
d1 - Tab lead width	1.40		1.80
Above body	0.35		0.64

DIMENSIONS ARE IN MM

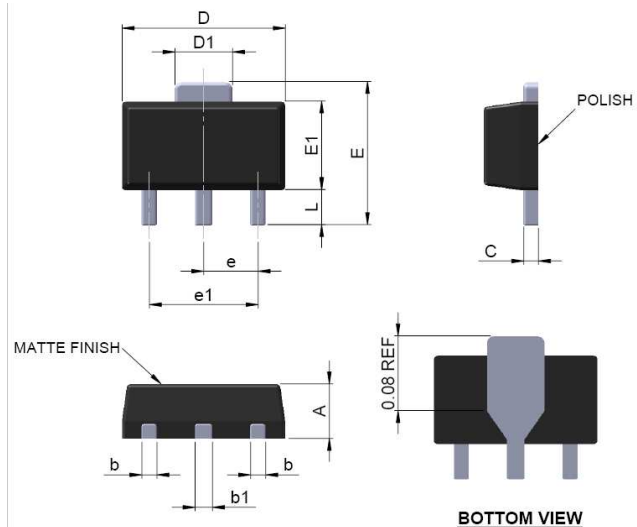

#### Mounting Configuration

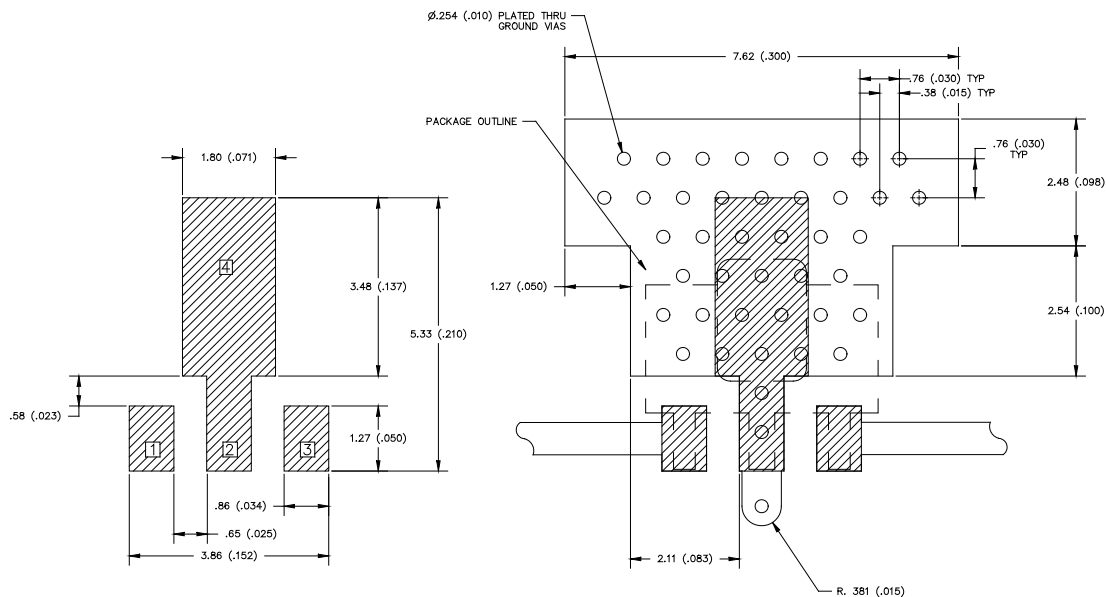

#### Notes:

1. Ground / thermal vias are critical for the proper performance of this device. Vias should use a .35 mm (#80/.0135”) diameter drill and have a final, plated thru diameter of .25 mm (.010”).
2. Add as much copper as possible to inner and outer layers near the part to ensure optimal thermal performance.
3. RF trace width depends upon the PC board material and construction.
4. All dimensions are in millimeters (inches). Angles are in degrees.

### Product Compliance Information

#### ESD Information



#### Caution! ESD-Sensitive Device

ESD Rating: Class 1A  
Value: Passes  $\geq 400$  V min.  
Test: Human Body Model (HBM)  
Standard: JEDEC Standard JESD22-A114

ESD Rating: Class III  
Value: Passes  $\geq 2000$  V min.  
Test: Charged Device Model (CDM)  
Standard: JEDEC Standard JESD22-C101

#### Solderability

Compatible with the latest version of J-STD-020, Lead free solder, 260 °C.

This part is compliant with EU 2002/95/EC RoHS directive (Restrictions on the Use of Certain Hazardous Substances in Electrical and Electronic Equipment).

#### MSL Rating

Level 3 at +260 °C convection reflow  
The part is rated Moisture Sensitivity Level x at TBD°C per JEDEC standard IPC/JEDEC J-STD-020.

### Contact Information

For the latest specifications, additional product information, worldwide sales and distribution locations, and information about TriQuint:

**Web:** [www.triquint.com](http://www.triquint.com)  
**Email:** [info-sales@tqs.com](mailto:info-sales@tqs.com)

**Tel:** +1.707.526.4498  
**Fax:** +1.503.526.1485

For technical questions and application information:

**Email:** [sjcapplcations.engineering@tqs.com](mailto:sjcapplcations.engineering@tqs.com)

### Important Notice

The information contained herein is believed to be reliable. TriQuint makes no warranties regarding the information contained herein. TriQuint assumes no responsibility or liability whatsoever for any of the information contained herein. TriQuint assumes no responsibility or liability whatsoever for the use of the information contained herein. The information contained herein is provided "AS IS, WHERE IS" and with all faults, and the entire risk associated with such information is entirely with the user. All information contained herein is subject to change without notice. Customers should obtain and verify the latest relevant information before placing orders for TriQuint products. The information contained herein or any use of such information does not grant, explicitly or implicitly, to any party any patent rights, licenses, or any other intellectual property rights, whether with regard to such information itself or anything described by such information.

TriQuint products are not warranted or authorized for use as critical components in medical, life-saving, or life-sustaining applications, or other applications where a failure would reasonably be expected to cause severe personal injury or death.