

**DC - 12 GHz Discrete power pHEMT**

**TGF2021-04**

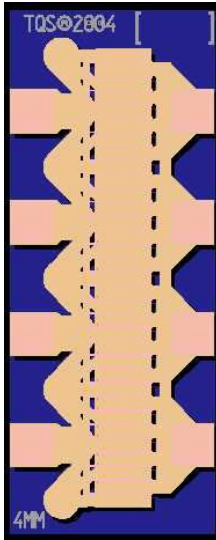

**Key Features and Performance**

- Frequency Range: DC - 12 GHz
- > 36 dBm Nominal Psat
- 59% Maximum PAE
- 11 dB Nominal Power Gain
- Suitable for high reliability applications
- 4mm x 0.35µm Power pHEMT
- Nominal Bias Vd = 8-12V, Idq = 300-500mA (Under RF Drive, Id rises from 300mA to 960mA)
- Chip Dimensions: 0.57 x 1.30 x 0.10 mm (0.022 x 0.051 x 0.004 in)

**Product Description**

The TriQuint TGF2021-04 is a discrete 4 mm pHEMT which operates from DC-12 GHz. The TGF2021-04 is designed using TriQuint’s proven standard 0.35µm power pHEMT production process.

The TGF2021-04 typically provides > 36 dBm of saturated output power with power gain of 11 dB. The maximum power added efficiency is 59% which makes the TGF2021-04 appropriate for high efficiency applications.

The TGF2021-04 is also ideally suited for Point-to-point Radio, High-reliability space, and Military applications.

The TGF2021-04 has a protective surface passivation layer providing environmental robustness.

Lead-free and RoHS compliant

**Primary Applications**

- Point-to-point Radio
- High-reliability space
- Military
- Base Stations
- Broadband Wireless Applications

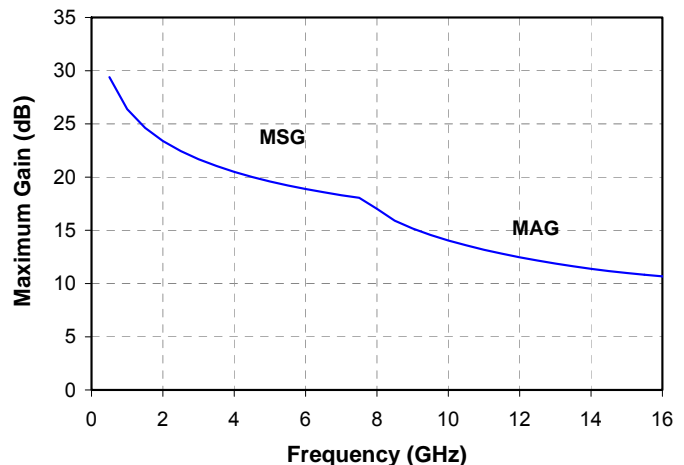

**TABLE I  
 MAXIMUM RATINGS**

Symbol	Parameter <u>1/</u>	Value	Notes
V <sup>+</sup>	Positive Supply Voltage	12.5 V	<u>2/</u>
V <sup>-</sup>	Negative Supply Voltage Range	-5V to 0V	
I <sup>+</sup>	Positive Supply Current	1.8 A	<u>2/</u>
I <sub>G</sub>	Gate Supply Current	28 mA	
P <sub>IN</sub>	Input Continuous Wave Power	31 dBm	<u>2/</u>
P <sub>D</sub>	Power Dissipation	See note 3	<u>2/ 3/</u>
T <sub>CH</sub>	Operating Channel Temperature	150 °C	<u>4/</u>
T <sub>M</sub>	Mounting Temperature (30 Seconds)	320 °C	
T <sub>STG</sub>	Storage Temperature	-65 to 150 °C	

- 1/ These ratings represent the maximum operable values for this device.
- 2/ Combinations of supply voltage, supply current, input power, and output power shall not exceed P<sub>D</sub>.
- 3/ For a median life time of 1E+6 hrs, Power dissipation is limited to:  
 $P_{D(max)} = (150\text{ °C} - T_{BASE}\text{ °C}) / 21.7\text{ (°C/W)}$
- 4/ Junction operating temperature will directly affect the device median time to failure (T<sub>M</sub>). For maximum life, it is recommended that junction temperatures be maintained at the lowest possible levels.

**TABLE II  
 DC PROBE CHARACTERISTICS  
 (T<sub>A</sub> = 25 °C, Nominal)**

Symbol	Parameter	Minimum	Typical	Maximum	Unit
I <sub>DSS</sub>	Saturated Drain Current	-	1200	-	mA
G <sub>m</sub>	Transconductance	-	1500	-	mS
V <sub>P</sub>	Pinch-off Voltage	-1.35	-1	-0.65	V
V <sub>BGS</sub>	Breakdown Voltage Gate-Source	-30	-	-8	V
V <sub>BGD</sub>	Breakdown Voltage Gate-Drain	-30	-	-15	V

Note: For TriQuint's 0.35um power pHEMT devices, RF breakdown >> DC breakdown

**TABLE III**  
**RF CHARACTERIZATION TABLE 1/**  
 (T<sub>A</sub> = 25 °C, Nominal)

SYMBOL	PARAMETER	Vd = 10V Idq = 300mA	Vd = 12V Idq = 300mA	UNITS
<b>Power Tuned:</b>				
Psat	Saturated Output Power	36.8	37.5	dBm
PAE	Power Added Efficiency	50	48	%
Gain	Power Gain	11	11	dB
$\Gamma_L$ 2/	Load Reflection coefficient	0.852 $\angle$ 1725	0.849 $\angle$ 170.7	-
<b>Efficiency Tuned:</b>				
Psat	Saturated Output Power	36	36.7	dBm
PAE	Power Added Efficiency	59	55	%
Gain	Power Gain	11.5	11	dB
$\Gamma_L$ 2/	Load Reflection coefficient	0.879 $\angle$ 167.5	0.874 $\angle$ 166.3	-

1/ Values in this table are scaled from measurements taken from a 1mm unit pHEMT cell at 10 GHz

2/ Optimum load impedance for maximum power or maximum PAE at 10 GHz

**TABLE IV**  
**THERMAL INFORMATION**

Parameter	Test Conditions	T <sub>CH</sub> (°C)	$\theta_{JC}$ (°C/W)	T <sub>M</sub> (HRS)
$\theta_{JC}$ Thermal Resistance (channel to backside of carrier)	Vd = 12 V Idq = 300 mA P <sub>diss</sub> = 3.6 W	148	21.7	1.2 E+6

Note: Assumes eutectic attach using 1.5 mil 80/20 AuSn mounted to a 20 mil CuMo Carrier at 70°C baseplate temperature.

### Linear Model for 1mm Unit pHEMT cell

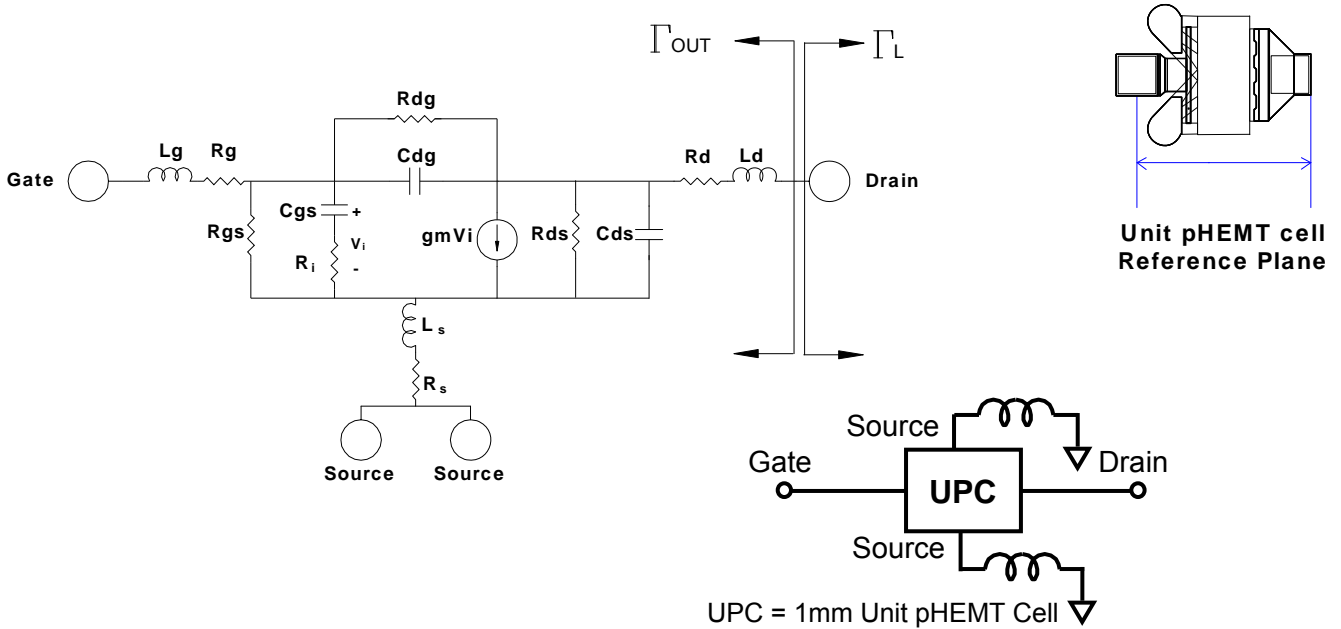

MODEL PARAMETER	Vd = 8V Idq = 75mA	Vd = 8V Idq = 100mA	Vd = 8V Idq = 125mA	Vd = 10V Idq = 75mA	Vd = 10V Idq = 100mA	Vd = 12V Idq = 75mA	UNITS
Rg	0.45	0.45	0.45	0.45	0.450	0.45	Ω
Rs	0.14	0.14	0.14	0.17	0.160	0.19	Ω
Rd	0.41	0.43	0.46	0.41	0.450	0.410	Ω
gm	0.310	0.318	0.314	0.296	0.303	0.286	S
Cgs	2.39	2.58	2.70	2.61	2.74	2.72	pF
Ri	1.22	1.19	1.20	1.24	1.23	1.27	Ω
Cds	0.20	0.201	0.201	0.198	0.199	0.196	pF
Rds	149.1	152.3	158.8	171.8	173.7	187.9	Ω
Cgd	0.115	0.107	0.101	0.101	0.098	0.096	pF
Tau	6.29	6.63	6.99	7.19	7.410	7.79	pS
Ls	0.009	0.009	0.009	0.009	0.010	0.010	nH
Lg	0.089	0.089	0.089	0.089	0.089	0.089	nH
Ld	0.120	0.120	0.120	0.120	0.120	0.120	nH
Rgs	33000	33000	35100	28900	35700	24400	Ω
Rgd	349000	425000	405000	305000	366000	238000	Ω

**Linear Model for 4mm pHEMT**

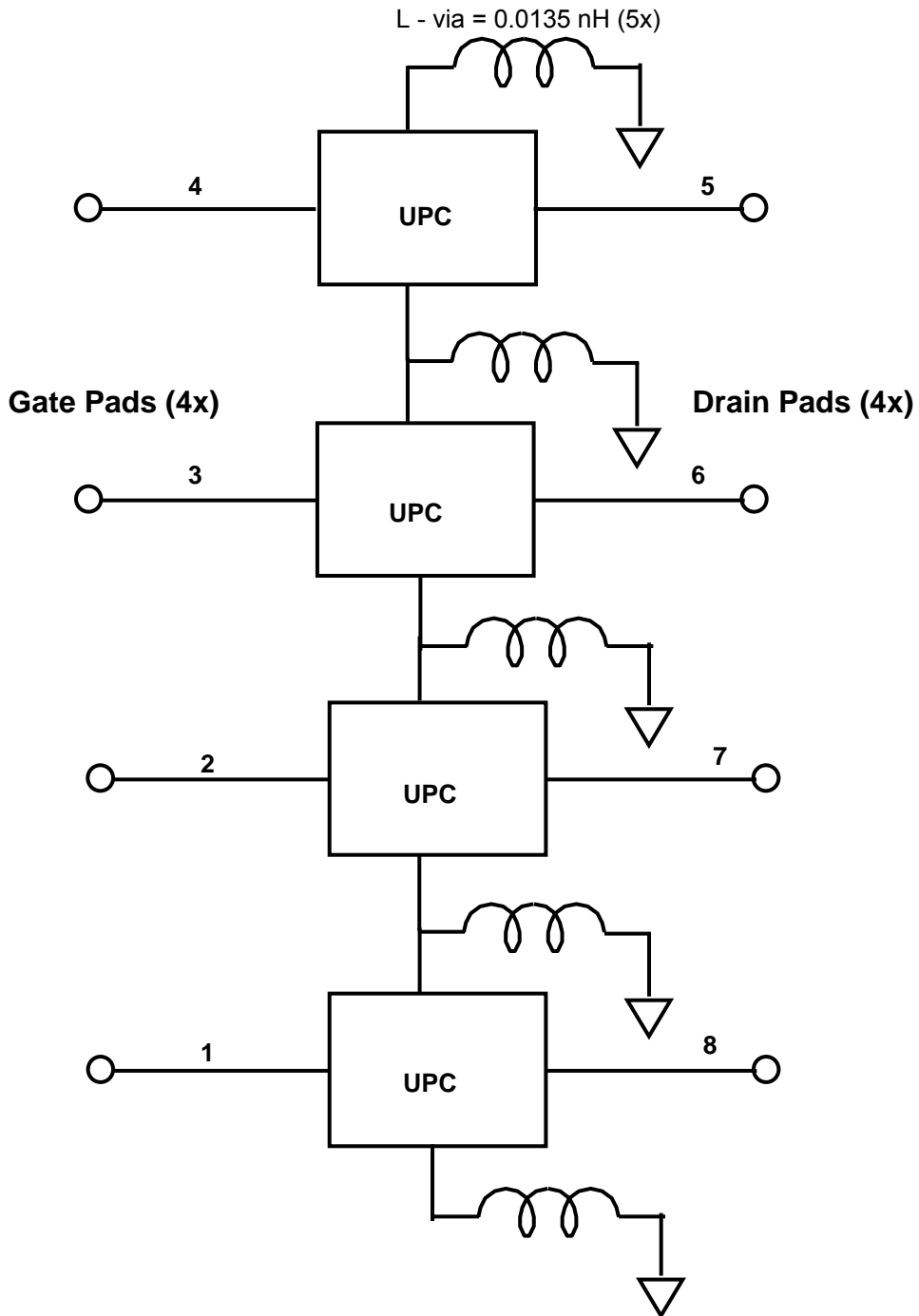

**Unmatched S-parameter for 4mm pHEMT**
**Bias Conditions: Vd=12V, Idq=300mA**

Frequency (GHz)	s11 dB	s11 ang deg	s21 dB	s21 ang deg	s12 dB	s12 ang deg	s22 dB	s22 ang deg
0.5	-0.365	-146.77	23.560	103.23	-35.222	15.89	-6.160	-161.81
1	-0.379	-163.15	17.793	91.99	-34.982	7.33	-5.842	-168.07
1.5	-0.380	-168.86	14.297	86.04	-34.977	4.06	-5.709	-169.15
2	-0.379	-171.78	11.782	81.48	-35.024	2.20	-5.581	-168.96
2.5	-0.377	-173.57	9.808	77.50	-35.099	0.95	-5.439	-168.34
3	-0.374	-174.80	8.176	73.84	-35.194	0.03	-5.280	-167.59
3.5	-0.370	-175.70	6.779	70.36	-35.308	-0.66	-5.108	-166.83
4	-0.366	-176.41	5.551	67.03	-35.437	-1.16	-4.925	-166.13
4.5	-0.362	-176.98	4.452	63.81	-35.581	-1.51	-4.735	-165.51
5	-0.358	-177.46	3.454	60.68	-35.739	-1.72	-4.541	-165.01
5.5	-0.353	-177.87	2.537	57.64	-35.908	-1.78	-4.346	-164.61
6	-0.348	-178.24	1.686	54.67	-36.087	-1.70	-4.152	-164.31
6.5	-0.343	-178.56	0.891	51.78	-36.275	-1.48	-3.962	-164.12
7	-0.337	-178.86	0.142	48.96	-36.469	-1.12	-3.776	-164.02
7.5	-0.332	-179.14	-0.566	46.21	-36.668	-0.61	-3.596	-164.01
8	-0.327	-179.40	-1.238	43.53	-36.870	0.05	-3.423	-164.07
8.5	-0.321	-179.64	-1.880	40.92	-37.073	0.85	-3.258	-164.19
9	-0.316	-179.88	-2.493	38.36	-37.274	1.80	-3.099	-164.38
9.5	-0.311	179.90	-3.082	35.87	-37.473	2.89	-2.948	-164.62
10	-0.306	179.68	-3.648	33.45	-37.667	4.12	-2.805	-164.90
10.5	-0.301	179.48	-4.193	31.08	-37.856	5.50	-2.669	-165.21
11	-0.296	179.27	-4.720	28.77	-38.039	7.02	-2.541	-165.56
11.5	-0.291	179.07	-5.229	26.51	-38.212	8.69	-2.419	-165.94
12	-0.286	178.88	-5.722	24.31	-38.373	10.53	-2.304	-166.33
12.5	-0.282	178.69	-6.200	22.16	-38.516	12.52	-2.196	-166.75
13	-0.277	178.50	-6.664	20.07	-38.638	14.65	-2.093	-167.18
13.5	-0.273	178.32	-7.114	18.02	-38.733	16.90	-1.997	-167.62
14	-0.269	178.13	-7.552	16.02	-38.801	19.23	-1.906	-168.07
14.5	-0.265	177.95	-7.979	14.07	-38.839	21.61	-1.820	-168.53
15	-0.261	177.77	-8.395	12.16	-38.849	24.03	-1.738	-168.99
15.5	-0.258	177.60	-8.800	10.29	-38.830	26.44	-1.662	-169.45
16	-0.254	177.42	-9.195	8.47	-38.784	28.84	-1.590	-169.92
16.5	-0.251	177.25	-9.581	6.68	-38.712	31.19	-1.521	-170.39
17	-0.248	177.08	-9.958	4.93	-38.616	33.48	-1.457	-170.86
17.5	-0.245	176.91	-10.328	3.22	-38.498	35.70	-1.396	-171.33
18	-0.242	176.74	-10.689	1.54	-38.361	37.83	-1.338	-171.79
18.5	-0.239	176.57	-11.043	-0.11	-38.207	39.87	-1.283	-172.26
19	-0.237	176.40	-11.390	-1.72	-38.037	41.81	-1.231	-172.72
19.5	-0.234	176.24	-11.730	-3.31	-37.855	43.65	-1.182	-173.18
20	-0.232	176.07	-12.064	-4.87	-37.661	45.38	-1.135	-173.63
20.5	-0.230	175.91	-12.392	-6.39	-37.458	47.01	-1.091	-174.08
21	-0.228	175.74	-12.715	-7.90	-37.248	48.53	-1.049	-174.53
21.5	-0.226	175.58	-13.032	-9.37	-37.032	49.95	-1.009	-174.97
22	-0.224	175.42	-13.345	-10.83	-36.812	51.26	-0.971	-175.41
22.5	-0.222	175.26	-13.653	-12.25	-36.588	52.47	-0.934	-175.85
23	-0.220	175.10	-13.957	-13.66	-36.362	53.59	-0.900	-176.28
23.5	-0.218	174.94	-14.256	-15.05	-36.135	54.61	-0.867	-176.71
24	-0.217	174.78	-14.552	-16.41	-35.908	55.53	-0.836	-177.13
24.5	-0.216	174.62	-14.844	-17.76	-35.682	56.35	-0.806	-177.55
25	-0.214	174.46	-15.133	-19.09	-35.460	57.08	-0.777	-177.97
25.5	-0.213	174.31	-15.418	-20.40	-35.242	57.72	-0.750	-178.38
26	-0.212	174.15	-15.701	-21.70	-35.032	58.28	-0.724	-178.79

Note: The s-parameters are calculated by connecting nodes 1-4 together, and nodes 5-8 together to form a 2-port network.

**Mechanical Drawing**

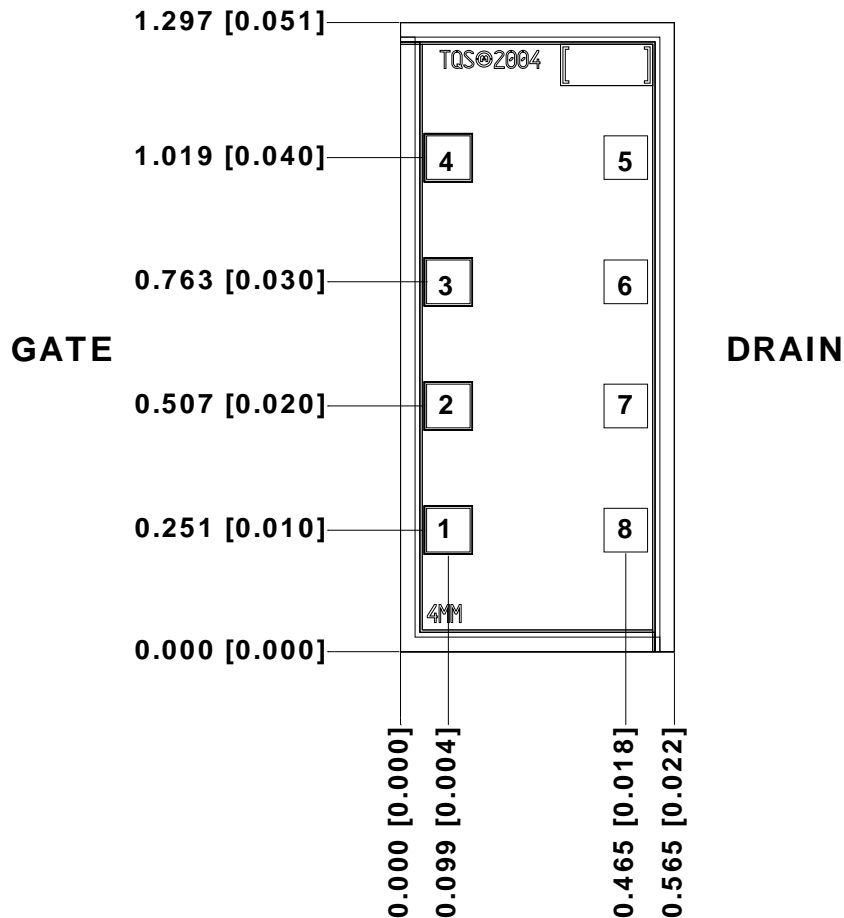

**Units: millimeters (inches)**

**Thickness: 0.100 (0.004)**

**Chip edge to bond pad dimensions are shown to center of bond pad**

**Chip size tolerance: +/- 0.051 (0.002)**

**GND IS BACKSIDE OF MMIC**

**Bond pads #1-4: (Gate) 0.090 x 0.090 (0.004 x 0.004)**

**Bond pads # 5-8: (Drain) 0.090 x 0.090 (0.004 x 0.004)**

*GaAs MMIC devices are susceptible to damage from Electrostatic Discharge. Proper precautions should be observed during handling, assembly and test.*

## **Assembly Process Notes**

### Reflow process assembly notes:

- Use AuSn (80/20) solder with limited exposure to temperatures at or above 300 °C for 30 sec
- An alloy station or conveyor furnace with reducing atmosphere should be used.
- Do not use flux
- Coefficient of thermal expansion matching is critical for long-term reliability.
- Devices must be stored in a dry nitrogen atmosphere.

### Component placement and adhesive attachment assembly notes:

- Vacuum pencils and/or vacuum collets are the preferred method of pick up.
- Air bridges must be avoided during placement.
- The force impact is critical during auto placement.
- Organic attachment can be used in low-power applications.
- Curing should be done in a convection oven; proper exhaust is a safety concern.
- Microwave or radiant curing should not be used because of differential heating.
- Coefficient of thermal expansion matching is critical.

### Interconnect process assembly notes:

- Thermosonic ball bonding is the preferred interconnect technique.
- Force, time, and ultrasonics are critical parameters.
- Aluminum wire should not be used.
- Devices with small pad sizes should be bonded with 0.0007-inch wire.
- Maximum stage temperature is 200 °C.