

25 Watt Discrete Power GaN on SiC HEMT

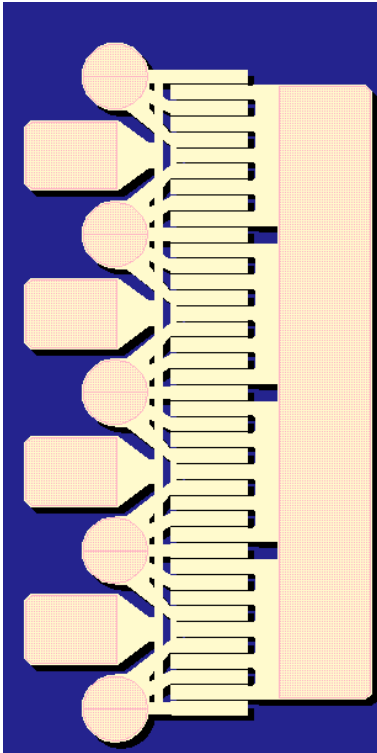

Key Features

- Frequency Range: DC - 18 GHz
- 43.9 dBm Nominal Psat at 3 GHz
- 56% Maximum PAE
- 17.8 dB Nominal Power Gain
- Bias: $V_d = 28 - 32$ V, $I_{dq} = 500$ mA, $V_g = -3.6$ V Typical
- Technology: 0.25 μ m Power GaN on SiC
- Chip Dimensions: 0.82 x 1.44 x 0.10 mm

Primary Applications

- Defense & Aerospace
- Broadband Wireless

Product Description

The TriQuint TGF2023-05 is a discrete 5.0 mm GaN on SiC HEMT which operates from DC-18 GHz. The TGF2023-05 is designed using TriQuint's proven 0.25 μ m GaN production process. This process features advanced field plate techniques to optimize microwave power and efficiency at high drain bias operating conditions.

The TGF2023-05 typically provides 43.9 dBm of saturated output power with power gain of 17.8 dB at 3 GHz. The maximum power added efficiency is 56% which makes the TGF2023-05 appropriate for high efficiency applications.

Lead-free and RoHS compliant

Bias conditions: $V_d = 28$ V, $I_{dq} = 500$ mA, $V_g = -3.6$ V Typical

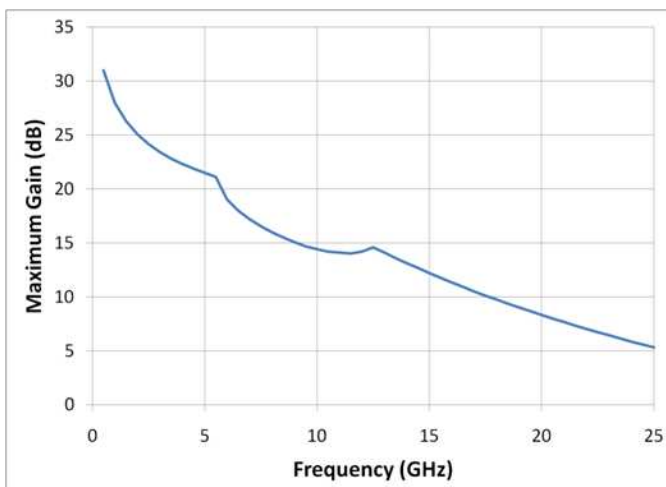

Datasheet subject to change without notice.

Table I
Absolute Maximum Ratings 1/

Symbol	Parameter	Value	Notes
Vd	Drain Voltage	40 V	<u>2/</u>
Vg	Gate Voltage Range	-50 to 0 V	
Vdg	Drain-Gate Voltage	80 V	
Id	Drain Current	5 A	<u>2/</u>
Ig	Gate Current	28 mA	
Pin	Input Continuous Wave Power	37 dBm	<u>2/</u>
Tch	Channel Temperature	200 °C	

1/ These ratings represent the maximum operable values for this device. Stresses beyond those listed under “Absolute Maximum Ratings” may cause permanent damage to the device and / or affect device lifetime. These are stress ratings only, and functional operation of the device at these conditions is not implied.

2/ Combinations of supply voltage, supply current, input power, and output power shall not exceed the maximum power dissipation listed in Table IV.

Table II
Recommended Operating Conditions

Symbol	Parameter	Value
Vd	Drain Voltage	28 - 32 V
Idq	Drain Current	500 mA
Id_Drive	Drain Current under RF Drive	1500 mA
Vg	Gate Voltage	-3.6 V

Table III
RF Characterization Table 1/

Bias: Vd = 28 V, Idq = 500 mA, Vg = -3.6V Typical

SYMBOL	PARAMETER	3 GHz	6 GHz	10 GHz	14 GHz	UNITS
Power Tuned:						
Psat	Saturated Output Power	43.9	43.2	43.0	41.6	dBm
PAE	Power Added Efficiency	56	56	49	39	%
Gain	Power Gain	17.8	11.9	9.4	6.1	dB
Efficiency Tuned:						
Psat	Saturated Output Power	42.6	41.5	42.7	41.6	dBm
PAE	Power Added Efficiency	62	62	51	40	%
Gain	Power Gain	17.1	12.5	9.7	6.0	dB

SYMBOL	PARAMETER	3 GHz	6 GHz	10 GHz	14 GHz	UNITS
Power Tuned:						
Rp <u>2/</u>	Parallel Resistance	79.3	81.9	61.5	49.9	Ω -mm
Cp <u>2/</u>	Parallel Capacitance	0.524	0.348	0.426	0.432	pF/mm
Efficiency Tuned:						
Rp <u>2/</u>	Parallel Resistance	153	171	72.1	53.1	Ω -mm
Cp <u>2/</u>	Parallel Capacitance	0.426	0.372	0.414	0.472	pF/mm

1/ Values in this table are engineering estimates scaled from measurements on the 1.25 mm GaN/SiC unit cell (see TGF2023-01 datasheet)

2/ Large signal equivalent output network (normalized) (see figure, pg 7)

Table IV
Power Dissipation and Thermal Properties 1/

Parameter	Test Conditions	Value	Notes
Maximum Power Dissipation	Tbaseplate = 70 °C	Pd = 32.2 W Tchannel = 200 °C Tm = 1.5E+6 Hrs	<u>2/</u>
Thermal Resistance, θ_{jc}	Vd = 28 V Id = 500 mA Pd = 14 W Tbaseplate = 70 °C	θ_{jc} = 4.0 (°C/W) Tchannel = 126 °C Tm = 6.4E+8 Hrs	
Thermal Resistance, θ_{jc} Under RF Drive	Vd = 28 V Id = 1540 mA Pout = 43.9 dBm Pd = 19.0 W Tbaseplate = 70 °C	θ_{jc} = 4.0 (°C/W) Tchannel = 146 °C Tm = 1.0E+8 Hrs	
Mounting Temperature	30 Seconds	320 °C	
Storage Temperature		-65 to 150 °C	

1/ Assumes eutectic attach using 1mil thick 80/20 AuSn mounted to a 10mil CuMo Carrier Plate

2/ Channel operating temperature will directly affect the device median lifetime. For maximum life, it is recommended that channel temperatures be maintained at the lowest possible levels.

Median Lifetime vs Channel Temperature

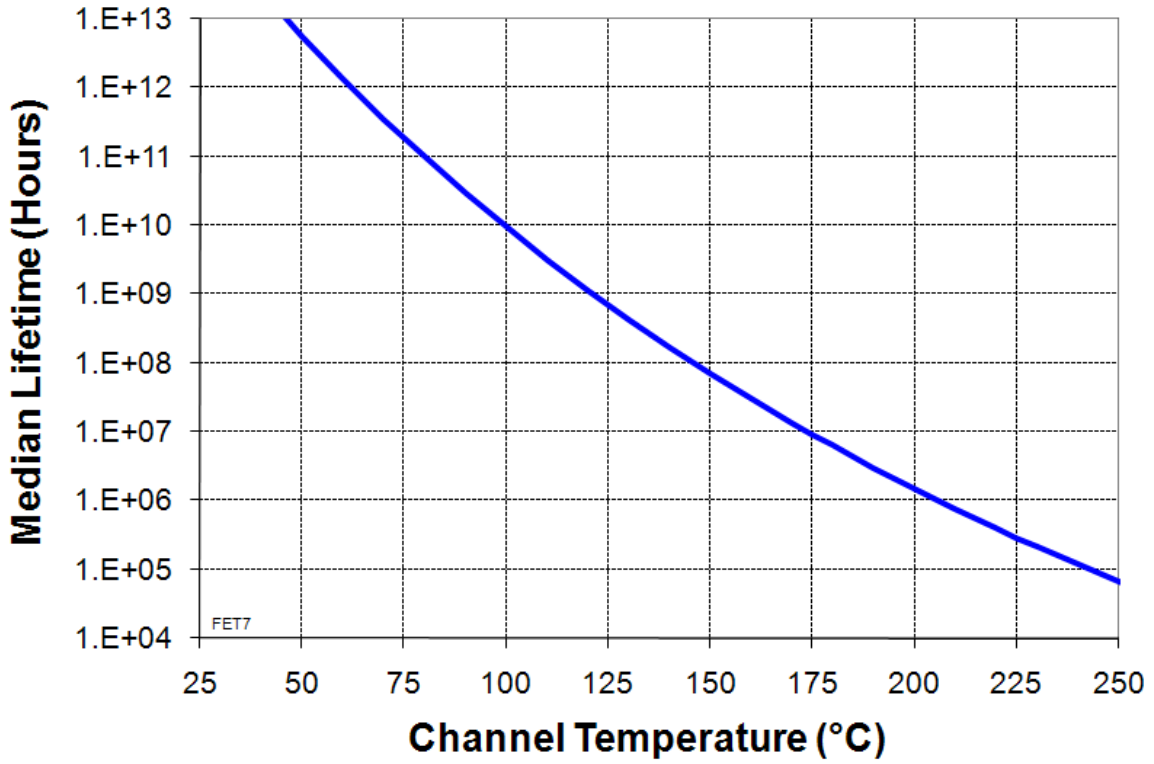

Linear Model for 1.25 mm Unit GaN Cell (UGC)

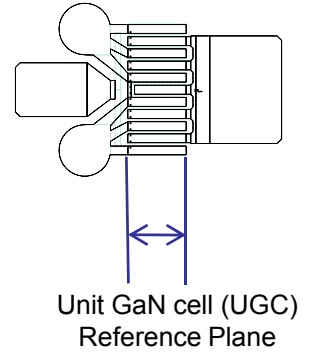
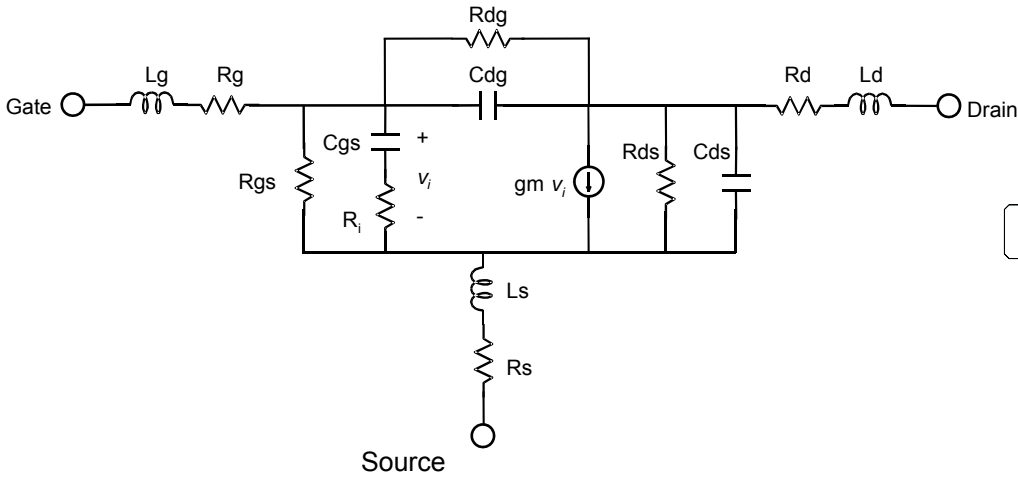

MODEL PARAMETER	Vd=28V Idq=125mA	UNITS
Rg	0.78	Ω
Rs	0.13	Ω
Rd	1.28	Ω
gm	0.270	S
Cgs	1.79	pF
Ri	0.26	Ω
Cds	0.308	pF
Rds	123.6	Ω
Cgd	0.064	pF
Tau	2.78	pS
Ls	0.0058	nH
Lg	-0.013	nH
Ld	0.018	nH
Rgs	8900	Ω
Rgd	1730000	Ω

Complete 5mm GaN HEMT Linear Model

Includes 4 UGC, 5 vias, and 8 bonding pads

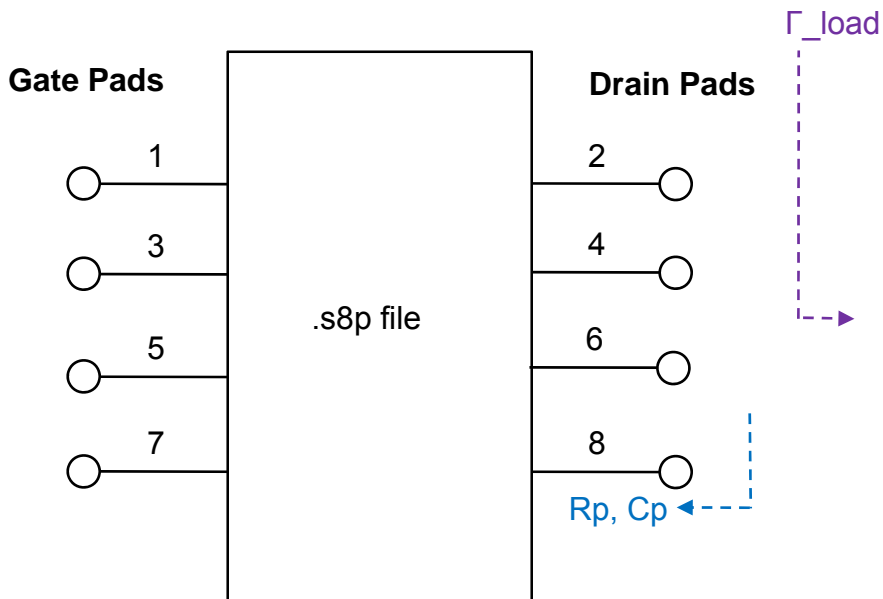

Mechanical Drawing

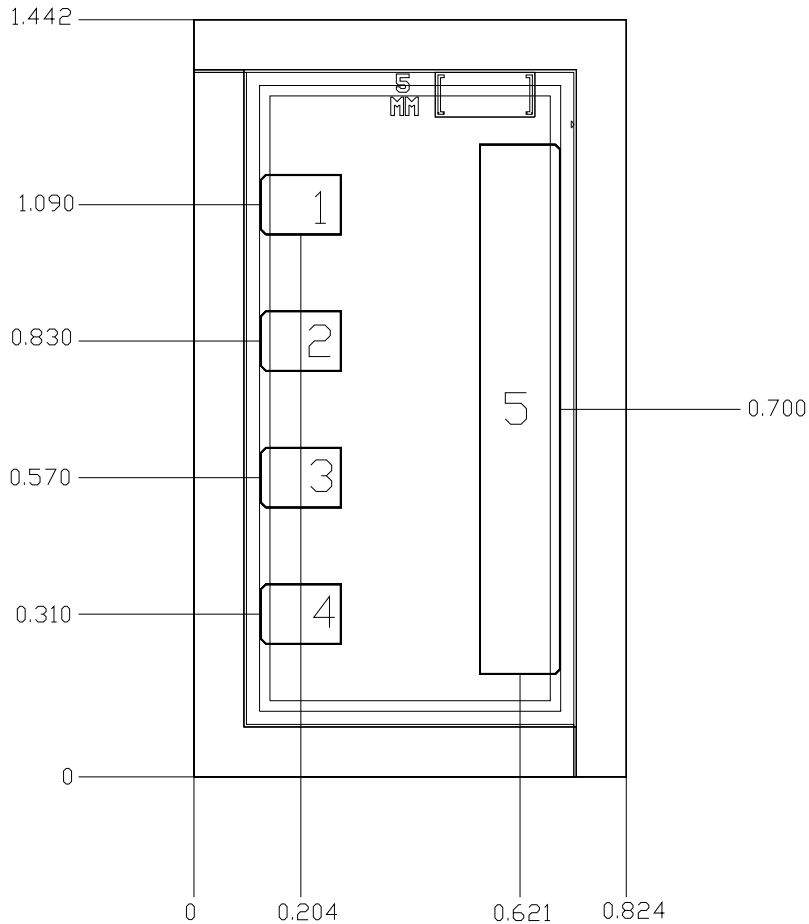

Units: millimeters

Thickness: 0.100

Die x,y size tolerance: +/- 0.050

Chip edge to bond pad dimensions are shown to center of pad

Ground is backside of die

Bond Pad #1, #2, #3, #4	Vg	0.154 x 0.115
Bond Pad #5	Vd	0.154 x 1.010

GaAs MMIC devices are susceptible to damage from Electrostatic Discharge. Proper precautions should be observed during handling, assembly and test.

Assembly Notes

Component placement and adhesive attachment assembly notes:

- Vacuum pencils and/or vacuum collets are the preferred method of pick up.
- Air bridges must be avoided during placement.
- The force impact is critical during auto placement.
- Organic attachment (i.e. epoxy) can be used in low-power applications.
- Curing should be done in a convection oven; proper exhaust is a safety concern.

Reflow process assembly notes:

- Use AuSn (80/20) solder and limit exposure to temperatures above 300°C to 3-4 minutes, maximum.
- An alloy station or conveyor furnace with reducing atmosphere should be used.
- Do not use any kind of flux.
- Coefficient of thermal expansion matching is critical for long-term reliability.
- Devices must be stored in a dry nitrogen atmosphere.

Interconnect process assembly notes:

- Ball bonding is the preferred interconnect technique, except where noted on the assembly diagram.
- Force, time, and ultrasonics are critical bonding parameters.
- Aluminum wire should not be used.
- Devices with small pad sizes should be bonded with 0.0007-inch wire.

Ordering Information

Part	ECCN	Package Style
TGF2023-05	3A001.b.3.b	GaN on SiC Die

GaAs MMIC devices are susceptible to damage from Electrostatic Discharge. Proper precautions should be observed during handling, assembly and test.