

17 - 27 GHz Upconverter

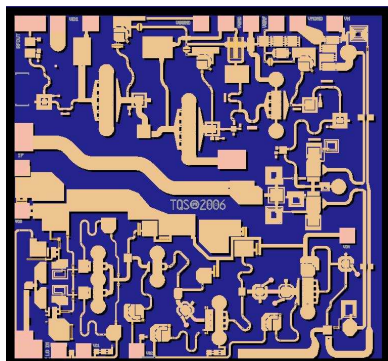

Measured Performance

Vd = 5V, Idq = 425mA, Vmxr = Vdbl = -0.9V
IF = 2GHz @ -8dBm, +2dBm LO

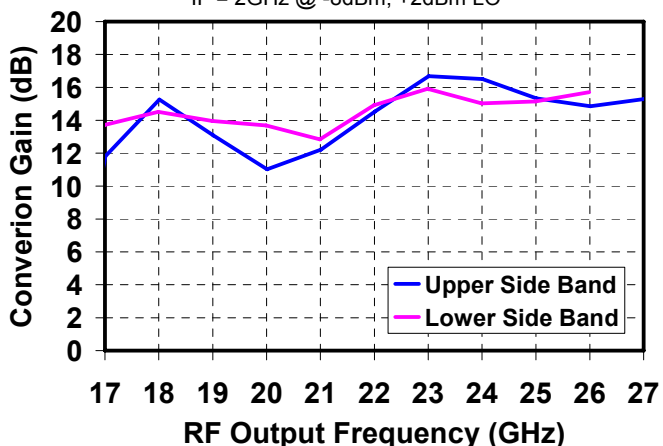

Vd = 5V, Idq = 425mA, Vmxr = Vdbl = -0.9V
IF = 2GHz +/- 5MHz @ -8dBm Input/Tone, +2dBm LO

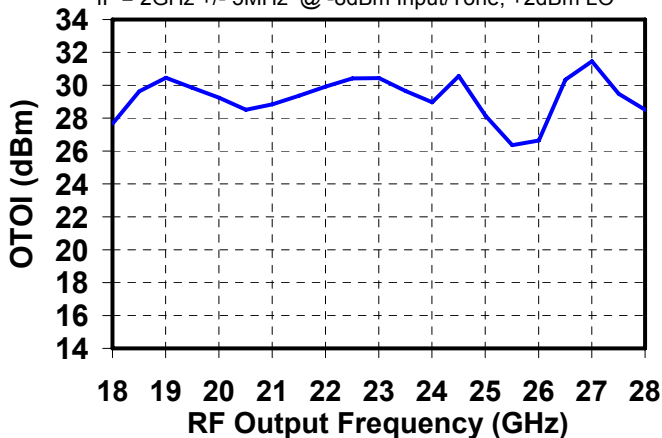

Key Features

- RF Output Frequency Range: 17 - 27 GHz
- LO Input Frequency Range: 8 -13 GHz
- IF Input Frequency Range: 0.5 - 3 GHz
- 13 dB Conversion Gain
- 28 dBm OTOI
- 30 dBc LO Isolation
- Bias: Vd = 5 V, Idq = 425 mA, Vg = -0.5 V Typical
- Technology: 3MI 0.25 um Power PHEMT
- Chip Dimensions: 2.07 x 1.93 x 0.1mm

Primary Applications

- Point-to-Point Radio
- Ku Band Sat-Com

Product Description

The TriQuint TGC4405 is a multifunction chip. It is an upconverter with RF output frequencies of 17 to 27 GHz. It contains a frequency doubler and local oscillator (LO) amplifier, operating at LO Input frequencies of 8 - 13 GHz. The part is designed using TriQuint's 0.25 um 3MI power pHEMT process.

The TGC4405 nominally provides 13 dB Conversion Gain and 28 dBm OTOI when operated with LO inputs from 2 - 5 dBm. The part also achieves 30 dBc typical isolation between the fundamental and doubled frequency.

The TGC4405 is ideally suited for low cost markets such as Point-to-Point Radio, and Ku-band Satellite Communications.

The TGC4405 is 100% DC and RF tested on-wafer to ensure performance compliance.

The TGC4405 has a protective surface passivation layer providing environmental robustness.

Lead-Free & RoHS compliant

Datasheet subject to change without notice.

Table I
Absolute Maximum Ratings 1/

Symbol	Parameter	Value	Notes
Vd-Vg	Drain to Gate Voltage	12 V	
Vd	Drain Supply Voltage	8 V	2/
Vmxr	Mixer Supply Voltage Range	-5 to 0 V	
Vdbl	Doubler Supply Voltage Range	-5 to 0 V	
Vg	Gate Supply Voltage Range	-5 to 0 V	
Id	Drain Supply Current	817 mA	2/
Ig	Gate Supply Current Range	-3.3 to 56.7 mA	
Imxr	Mixer Supply Current Range	-0.75 to 10.5 mA	
Idbl	Doubler Supply Current Range	-0.6 to 16.8 mA	
Pin _{LO}	LO Input Continuous Wave Power	18 dBm	2/
Pin _{IF}	IF Input Continuous Wave Power	21 dBm	2/

- 1/ These ratings represent the maximum operable values for this device. Stresses beyond those listed under “Absolute Maximum Ratings” may cause permanent damage to the device and / or affect device lifetime. These are stress ratings only, and functional operation of the device at these conditions is not implied.
- 2/ Combinations of supply voltage, supply current, input power, and output power shall not exceed Pd (as listed in “Thermal Information”).

Table II
Recommended Operating Conditions

Symbol	Parameter	Value
Vd	Drain Voltage	5 V
Idq	Drain Current	425 mA
Vg	Gate Voltage	-0.5 V, typical
Vmxr	Mixer Voltage	-0.9 V
Vdbl	Doubler Voltage	-0.9 V

See assembly diagram for bias instructions.

Table III
RF Characterization Table

Bias: $V_d = 5\text{ V}$, $I_{dq} = 425\text{ mA}$, $V_{mxr} = V_{dbl} = -0.9\text{V}$, $V_g = -0.5\text{V}$ Typical

SYMBOL	PARAMETER	TEST CONDITIONS	NOMINAL	UNITS
F_{LO}	LO Input Frequency Range		8 - 13	GHz
F_{IF}	IF Input Frequency Range		0.5 - 3	GHz
Gain	Conversion Gain	$f = 17 - 27\text{ GHz}$	13	dB
ORL	Output Return Loss	$f = 17 - 27\text{ GHz}$	-10	dB
OTOI	Output Third Order Intercept @ IF Input = -8dBm/Tone	$f = 17 - 27\text{ GHz}$	28	dBm
LO_Isol	LO Isolation	$f = 17 - 27\text{ GHz}$	30	dBc

Table IV
Power Dissipation and Thermal Properties

Parameter	Test Conditions	Value	Notes
Maximum Power Dissipation	Tbaseplate = 70 °C	Pd = 2.9 W Tchannel = 150 °C Tm = 1.0E+6 Hrs	1/ 2/
Thermal Resistance, θ_{jc}	Vd = 5 V Id = 425 mA Pd = 2.13 W	θ_{jc} = 27.4 (°C/W) Tchannel = 128 °C Tm = 7E+6 Hrs	
Mounting Temperature	30 Seconds	320 °C	
Storage Temperature		-65 to 150 °C	

- 1/ For a median life of 1E+6 hours, Power Dissipation is limited to

$$P_d(\max) = (150\text{ °C} - T_{\text{base}}\text{ °C})/\theta_{jc}.$$
- 2/ Channel operating temperature will directly affect the device median time to failure (MTTF). For maximum life, it is recommended that channel temperatures be maintained at the lowest possible levels.

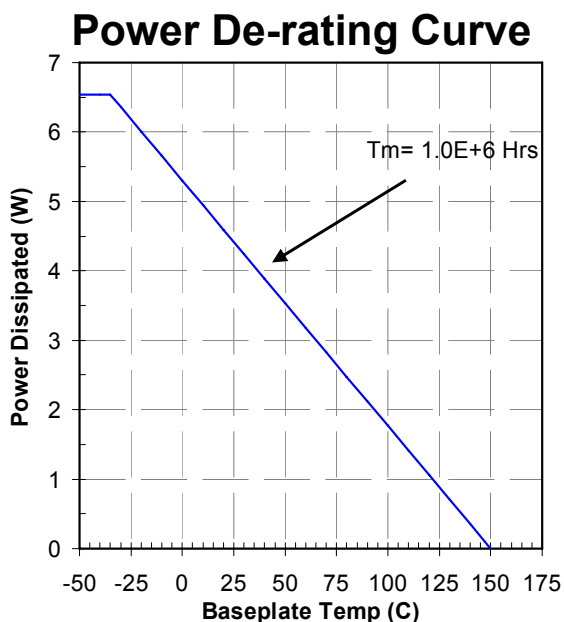

Measured Data

Vd = 5V, Idq = 425mA, Vmxr = Vdbl = -0.9V
 IF = 2GHz @ -8dBm, +2dBm LO

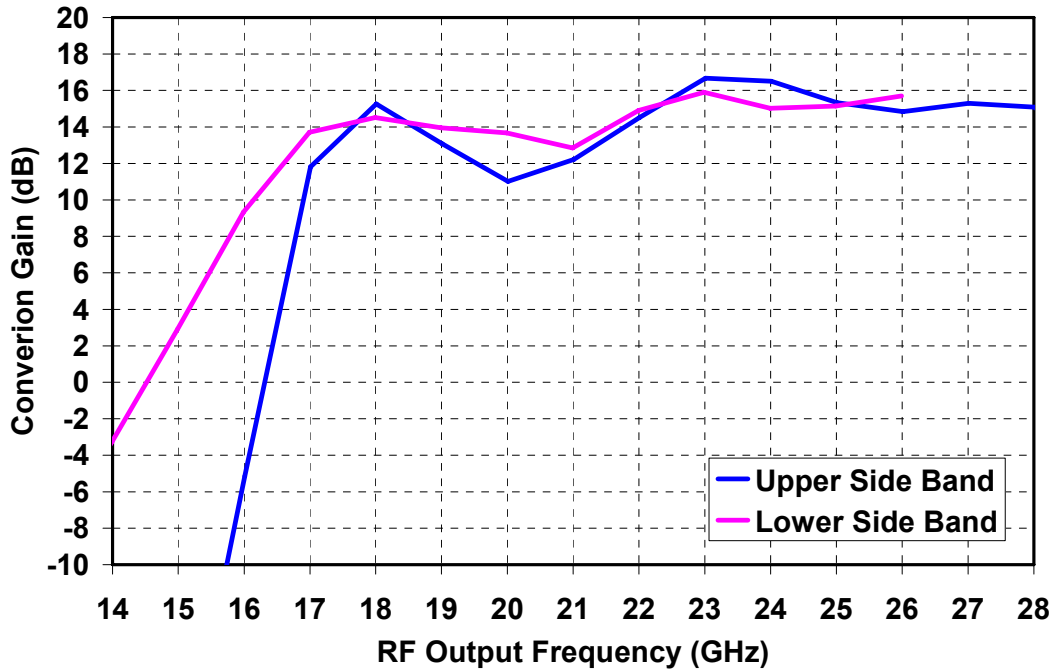

Vd = 5V, Idq = 425mA, Vmxr = Vdbl = -0.9V
 IF = 2GHz +/- 5MHz @ -8dBm Input/Tone, +2dBm LO

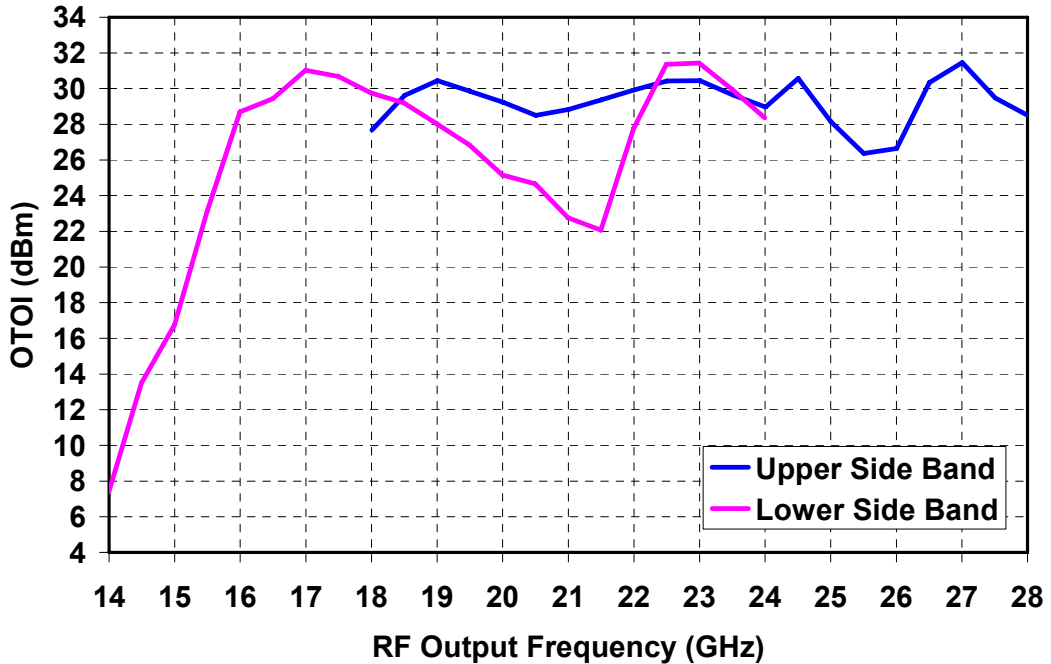

Measured Data

Vd = 5V, Idq = 425mA, Vmxr = Vdbl = -0.9V
IF = 2GHz @ -8dBm, +2dBm LO

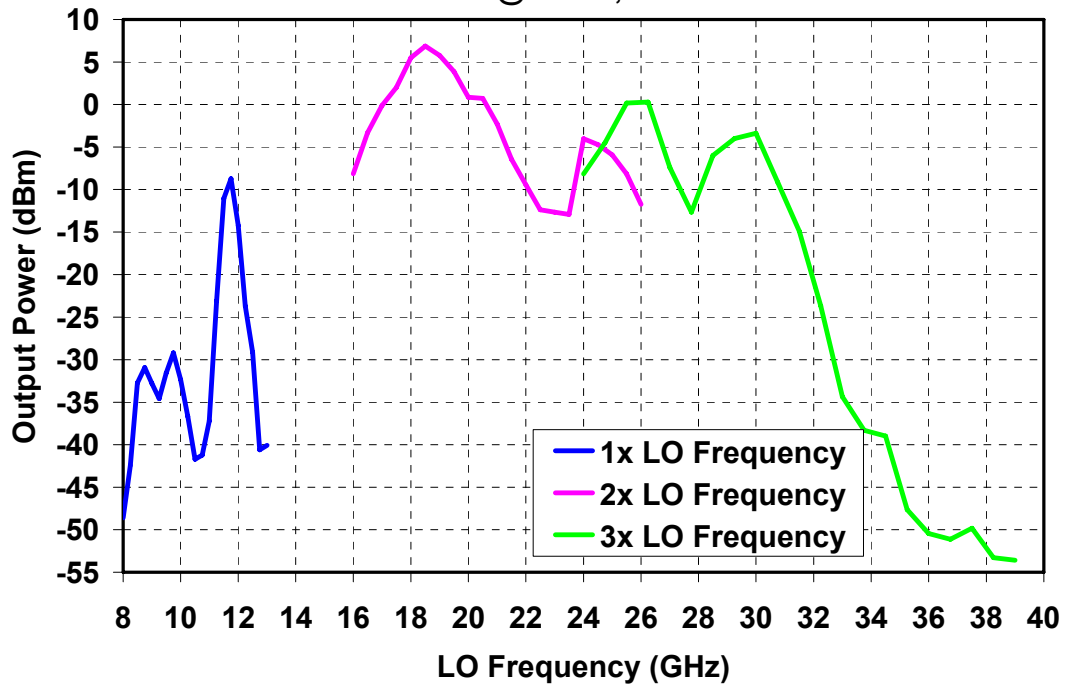

Vd = 5V, Idq = 425mA, Vmxr = Vdbl = -0.9V
IF = 2GHz @ -8dBm, +2dBm LO

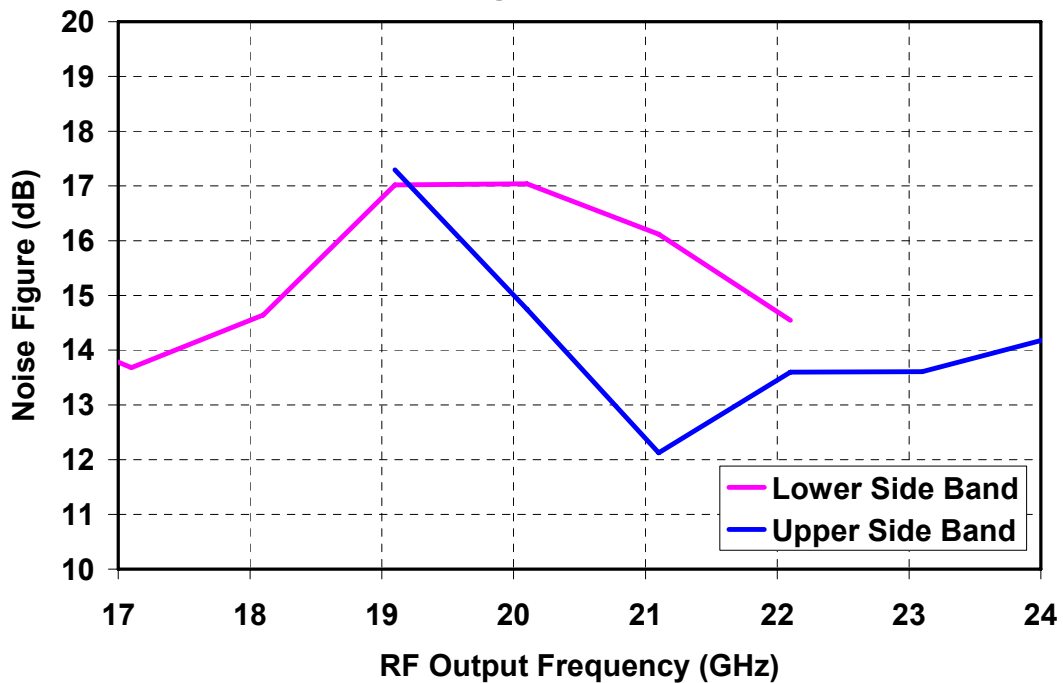

Measured Data

Swept LO Power
 $V_d = 5V$, $I_{dq} = 425mA$, $V_{mxr} = V_{dbl} = -0.9V$
 $IF = 2GHz @ -8dBm$, LO Frequency = 20GHz

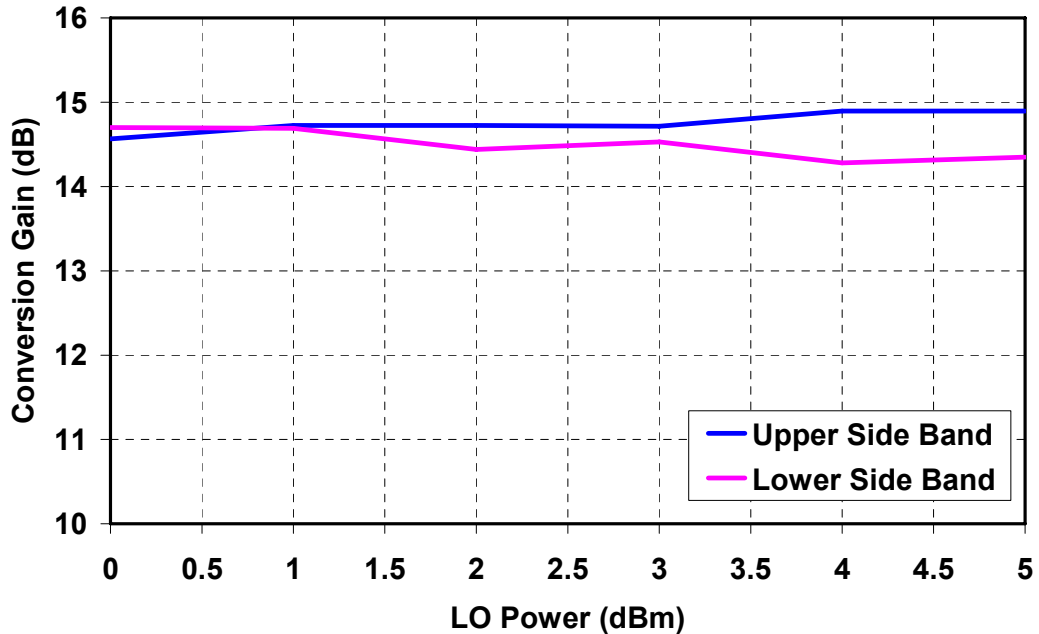

Swept IF @ -8dBm
 $V_d = 5V$, $I_{dq} = 425mA$, $V_{mxr} = V_{dbl} = -0.9V$
 RF Frequency = 21GHz, +2dBm LO

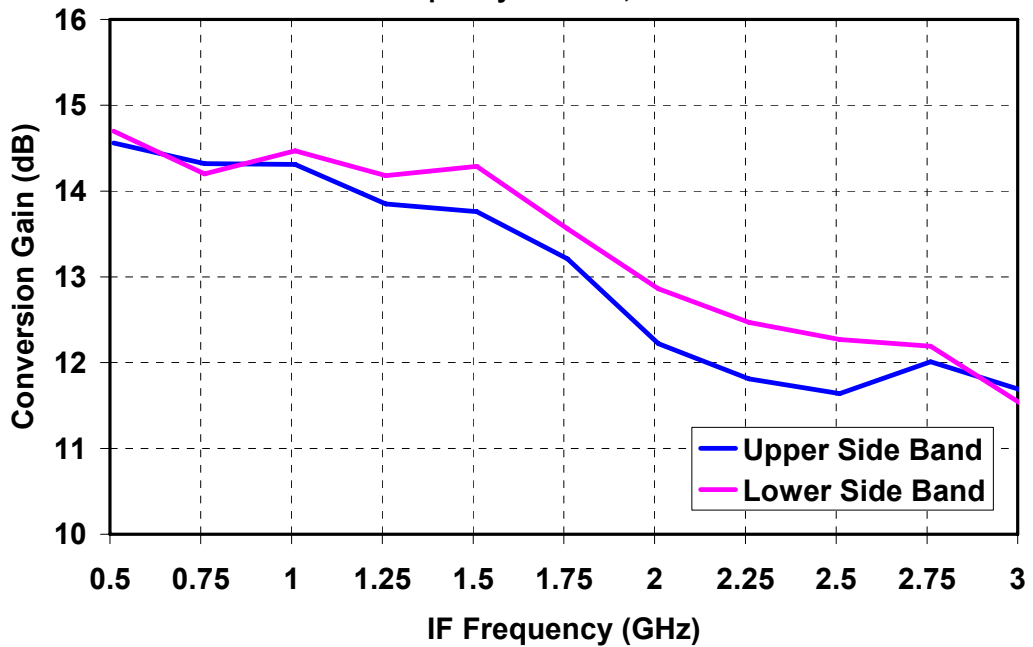

Electrical Schematic

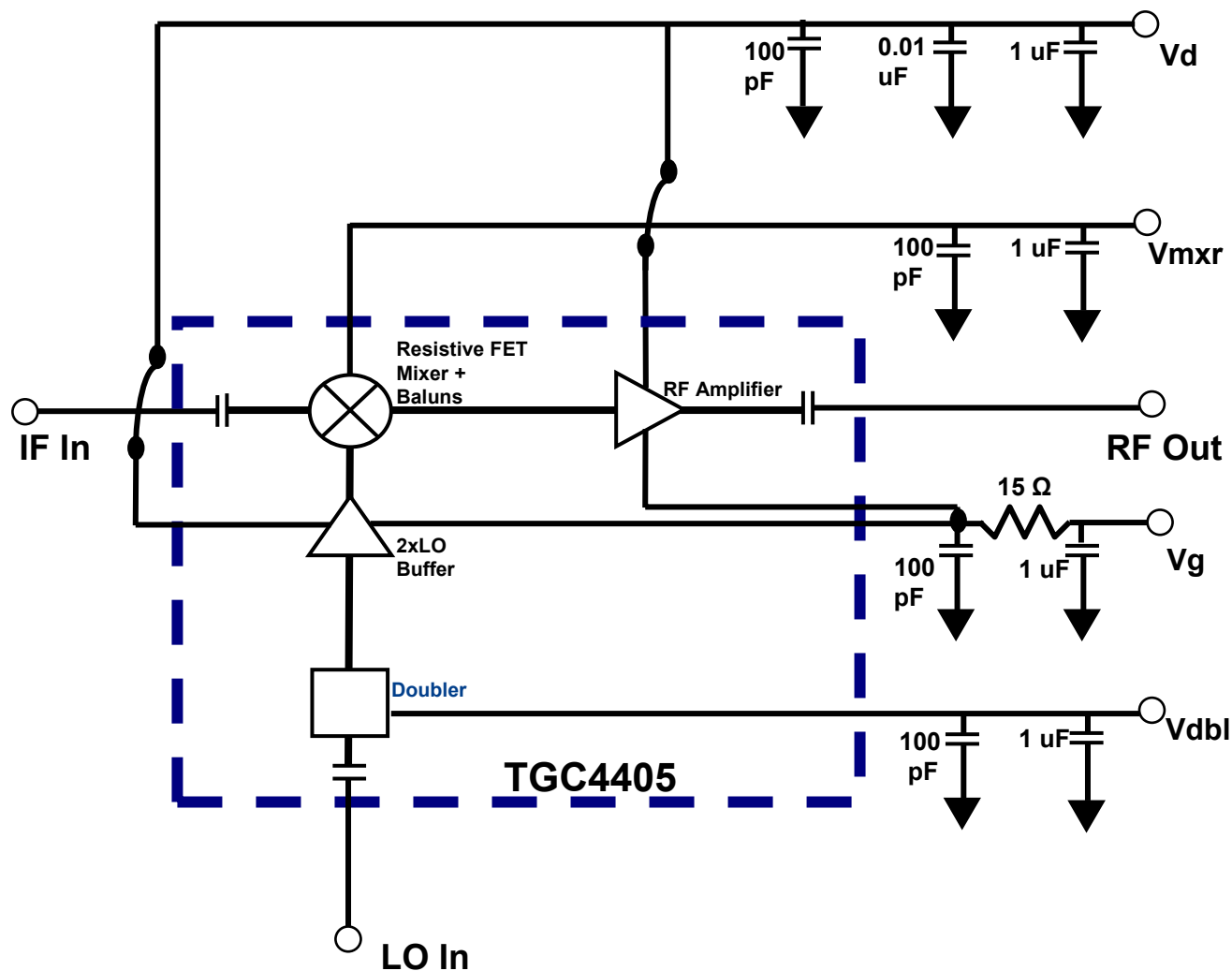

Bias Procedures

Bias-up Procedure

- Vg set to -1.5 V
- Vd set to +5 V
- Vmxr set to -0.9V
- Vdbl set to -0.9 V
- Adjust Vg more positive until Idq is 425 mA.
This will be ~ Vg = -0.5 V
- Apply signals to LO and IF input

Bias-down Procedure

- Turn off signals
- Reduce Vg to -1.5V. Ensure Id ~ 0 mA
- Turn Vdbl to 0V
- Turn Vmxr to 0V
- Turn Vd to 0V
- Turn Vg to 0V

Mechanical Drawing

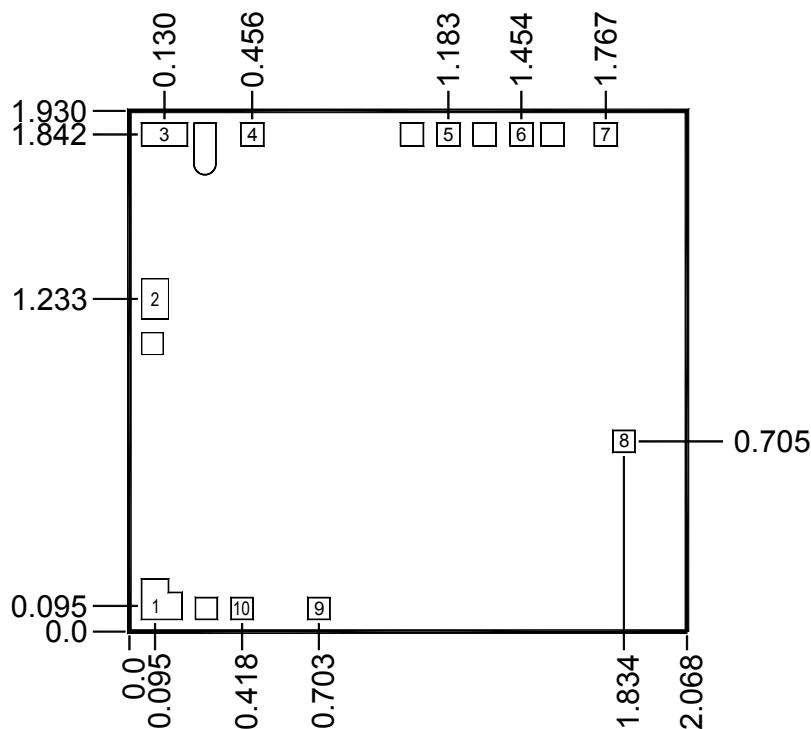

Units: millimeters

Thickness: 0.10

Die x,y size tolerance: +/- 0.05

Chip edge to bond pad dimensions are shown to center of pad

Ground is backside of die

Bond Pad #1	LO In	0.100 x 0.100	Bond Pad #6	Vg	0.085 x 0.085
Bond Pad #2	IF In	0.100 x 0.150	Bond Pad #7	Vmxr	0.085 x 0.085
Bond Pad #3	RF Out	0.170 x 0.085	Bond Pad #8	Vd	0.081 x 0.081
Bond Pad #4	Vd	0.085 x 0.085	Bond Pad #9	Vg	0.081 x 0.081
Bond Pad #5	Vd	0.085 x 0.085	Bond Pad #10	Vdbl	0.081 x 0.081

GaAs MMIC devices are susceptible to damage from Electrostatic Discharge. Proper precautions should be observed during handling, assembly and test.

Recommended Assembly Diagram

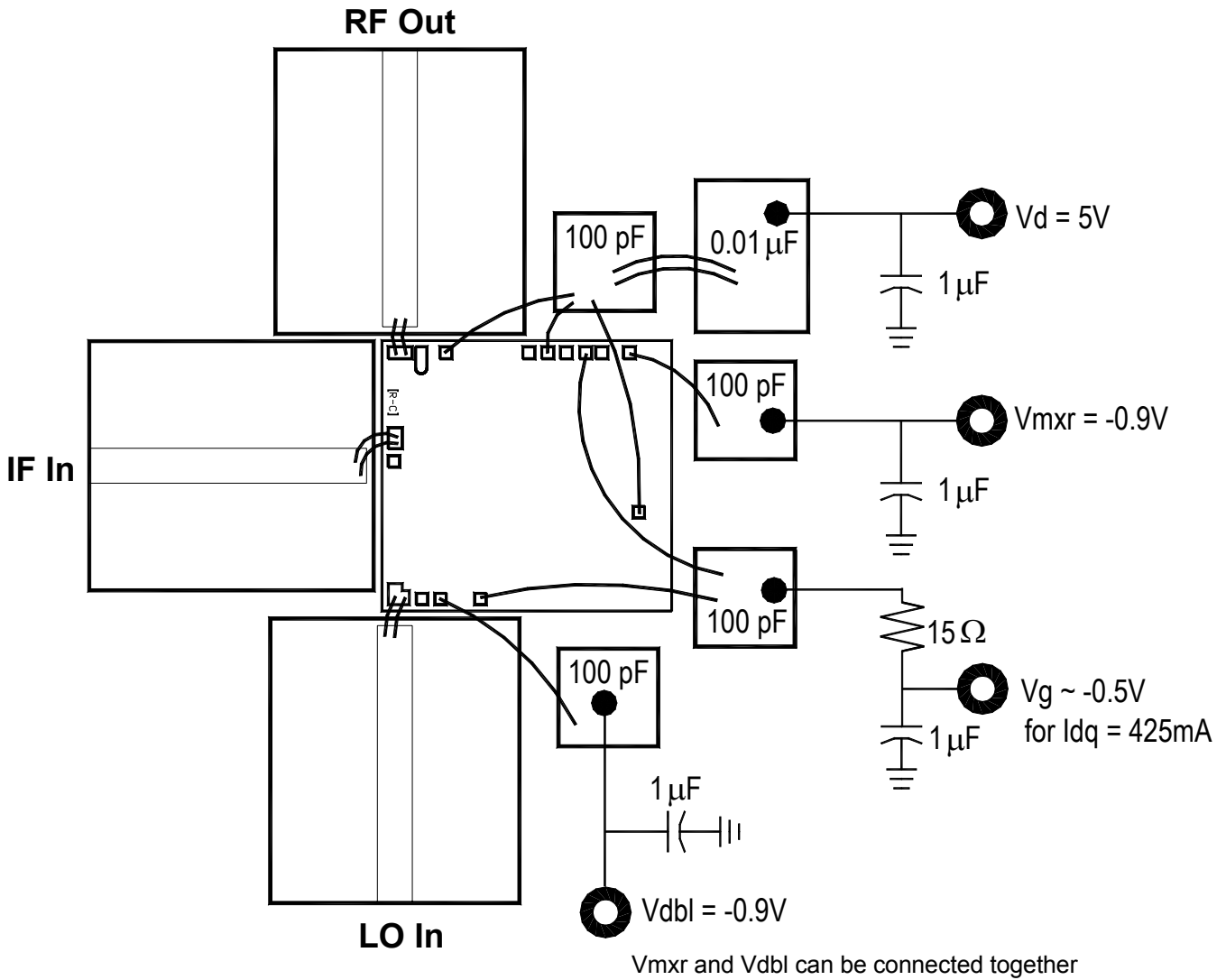

GaAs MMIC devices are susceptible to damage from Electrostatic Discharge. Proper precautions should be observed during handling, assembly and test.

Assembly Notes

Component placement and adhesive attachment assembly notes:

1. Vacuum pencils and/or vacuum collets are the preferred method of pick up.
2. Air bridges must be avoided during placement.
3. The force impact is critical during auto placement.
4. Organic attachment (i.e. epoxy) can be used in low-power applications.
5. Curing should be done in a convection oven; proper exhaust is a safety concern.

Reflow process assembly notes:

1. Use AuSn (80/20) solder and limit exposure to temperatures above 300°C to 3-4 minutes, maximum.
2. An alloy station or conveyor furnace with reducing atmosphere should be used.
3. Do not use any kind of flux.
4. Coefficient of thermal expansion matching is critical for long-term reliability.
5. Devices must be stored in a dry nitrogen atmosphere.

Interconnect process assembly notes:

1. Thermosonic ball bonding is the preferred interconnect technique.
2. Force, time, and ultrasonics are critical parameters.
3. Aluminum wire should not be used.
4. Devices with small pad sizes should be bonded with 0.0007-inch wire.

Ordering Information

Part	Package Style
TGC4405	GaAs MMIC Die

GaAs MMIC devices are susceptible to damage from Electrostatic Discharge. Proper precautions should be observed during handling, assembly and test.