

TGC4610-SM

K-Band Downconverter



Applications

- VSAT
- Point-to-Point Radio
- Test Equipment & Sensors

Product Features

- RF Frequency Range: 17 – 27 GHz
- IF Frequency: DC – 4 GHz
- LO Frequency: 6.5 – 15.5 GHz
- LO Input Power: 2 to 9 dBm
- Conversion Gain: 15 dB
- Noise Figure: ≤ 2.5 dB
- Package Dimensions: 5.0 x 5.0 x 1.3 mm

General Description

The TriQuint TGC4610-SM is a K-Band Image Reject Downconverter. The TGC4610-SM operates over an RF frequency range of 17 to 27 GHz and LO from 6.5 to 15.5 GHz with IF outputs from DC to 4 GHz. This part is designed using TriQuint's pHEMT production process.

The TGC4610-SM integrates an LNA, and image reject mixer driven by a multiplier. It typically provides an Input IP3 of 3 dBm at -25 dBm input power per tone and has a conversion gain of 15 dB and noise figure of 2.5 dB or less.

The TGC4610-SM is available in a low-cost, surface mount 28 lead 5x5 mm QFN package and is ideally suited for Point-to-Point Radio, and K-Band VSAT Ground Terminal applications.

Lead-free and RoHS compliant.

Evaluation Boards are available upon request.



28-pin 5x5 mm QFN package

Functional Block Diagram

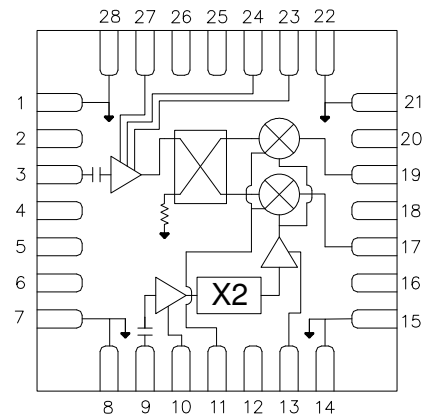

Pin Configuration

Pin #	Function Label
1, 7, 8, 14, 15, 21, 22, 28	GND
2, 4, 5, 6, 12, 16, 18, 20, 25, 26	NC
3	RF IN
9	LO IN
10	VDLO1
11	VGX
13	VDLO23
17	IF1
19	IF2
23	VDRF4V
24	VDRF
27	VGRF

Ordering Information

Part No.	ECCN	Description
TGC4610-SM	EAR99	K-band Downconverter

Standard T/R size = 500 pieces on a 13" reel.

Specifications

Absolute Maximum Ratings

Parameter	Rating
VDRF	6 V
VDLO	6 V
IDRF	150 mA
IDLO	375 mA
VGX, VGRF	-3 to 0 V
Power Dissipation	1.6 W
RF Input Power, 50Ω, T = 25°C	10 dBm
Channel Temperature, T _{ch}	200 °C
Storage Temperature	-65 to 125 °C

Operation of this device outside the parameter ranges given above may cause permanent damage.

Recommended Operating Conditions

Parameter	Min	Typ	Max	Units
Operating Temp. Range	-40	+25	+85	°C
VDRF		3		V
IDRF		68		mA
VDLO		3		V
IDLO		160		mA
VGRF		-0.65		V
VGX		-1.1		V
LO Input Power	2		9	dBm

Electrical specifications are measured at specified test conditions. Specifications are not guaranteed over all recommended operating conditions.

Electrical Specifications

Test conditions unless otherwise noted: IF Input Power = -25 dBm, LO Input Power = 5.5 dBm, VGX = -1.1 V, VDLO = 3 V, IDLO = 160 mA, VDRF = 3 V, IDRF = 68 mA, VGRF = -0.65 V.

Parameter	Conditions	Min	Typ	Max	Units
RF Frequency Range		17		27	GHz
LO Frequency Range		6.5		15.5	GHz
IF Frequency Range		DC		4	GHz
LO Input Power		2		9	dBm
Drain Current, LO (IDLO)			160		mA
Drain Current, RF (IDRF)			68		mA
Conversion Gain			15		dB
Input Third Order Intercept Point (IIP3)			3		dBm
Image Rejection (IMR)			20		dB
Noise Figure			2.5		dB

Specifications

Thermal and Reliability Information

Parameter	Condition	Rating
Thermal Resistance, θ_{JC} , measured to back of package	Tbase = 85 °C	$\theta_{JC} = 73.5 \text{ }^\circ\text{C/W}$
Channel Temperature (Tch), and Median Lifetime (Tm)	Tbase = 85 °C, VDRF = 3 V, IDRF = 68 mA VDLO = 3 V, IDLO = 160 mA P _{diss} = 0.68 W	Tch = 135 °C Tm = 5.8 E+6 Hours
Channel Temperature (Tch), and Median Lifetime (Tm) Under RF Drive	Tbase = 85 °C VDRF = 3 V, IDRF = 68 mA VDLO = 3 V, IDLO = 220 mA Pin = -25 dBm P _{diss} = 0.86 W	Tch = 148 °C Tm = 1.3 E+6 Hours

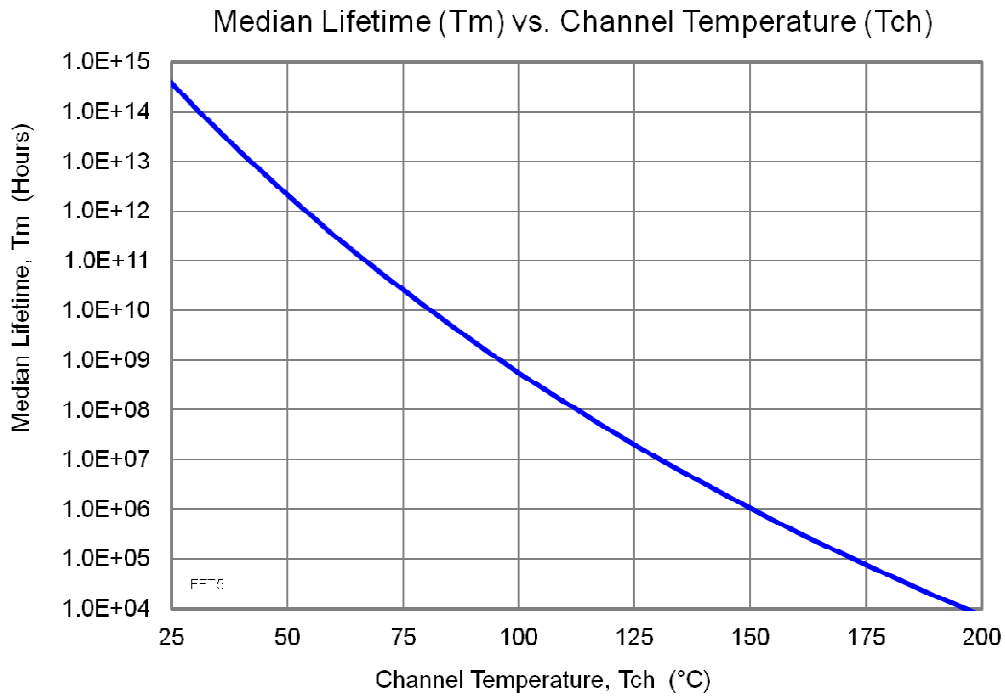

TGC4610-SM

K-Band Downconverter



Typical Performance

IF Input Power = -25 dBm, VDLO = 3 V, IDLO = 160 mA, VDRF = 3 V, IDRF = 68 mA, VGRF = -0.65 V.
 Data taken with external IF hybrid.

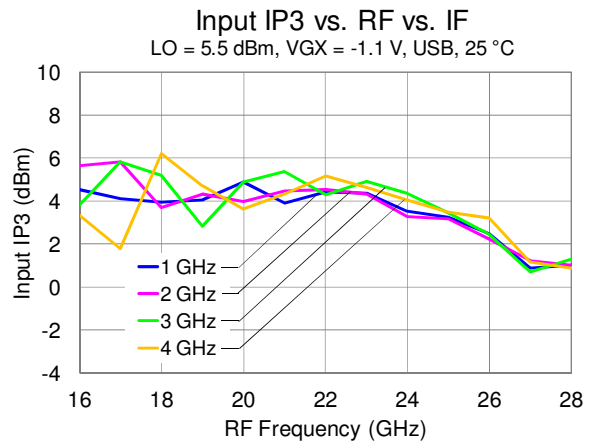
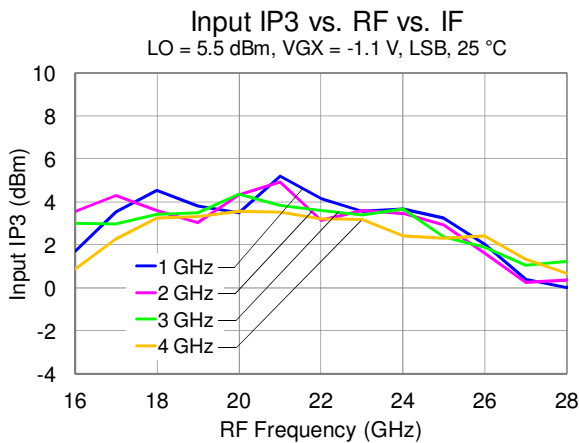
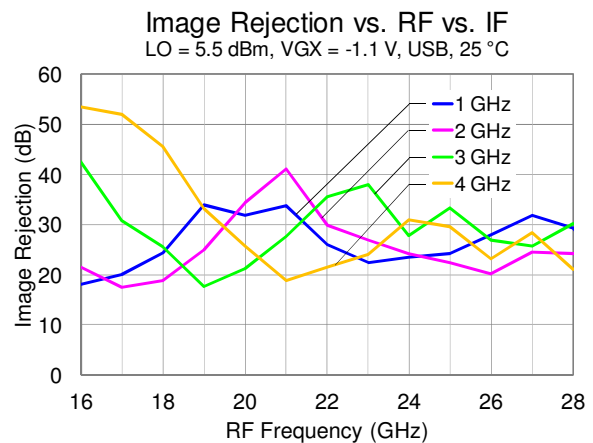
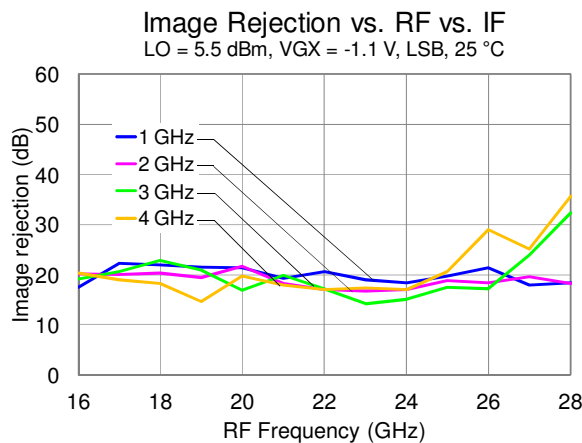
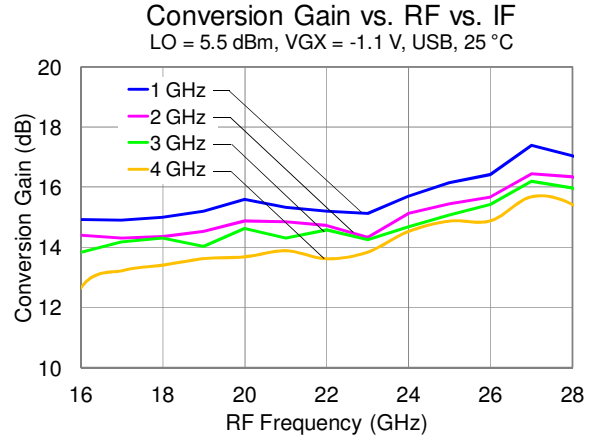
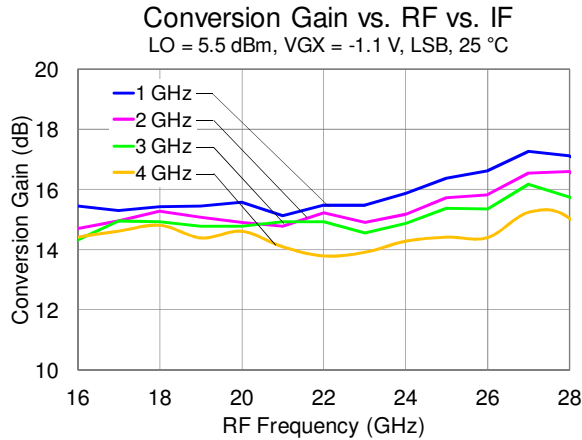

TGC4610-SM

K-Band Downconverter



Typical Performance

IF Input Power = -25 dBm, VDLO = 3 V, IDLO = 160 mA, VDRF = 3 V, IDRf = 68 mA, VGRF = -0.65 V.
 Data taken with external IF hybrid.

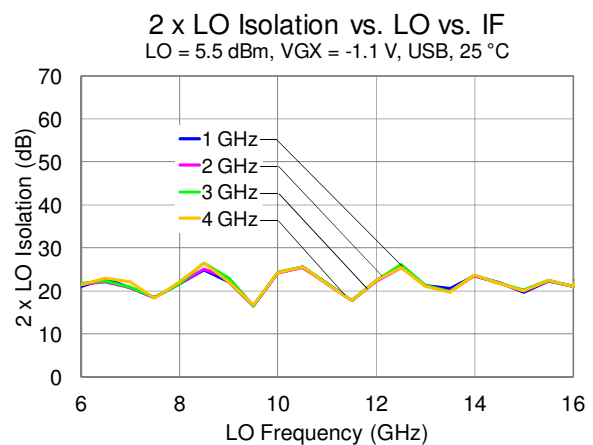
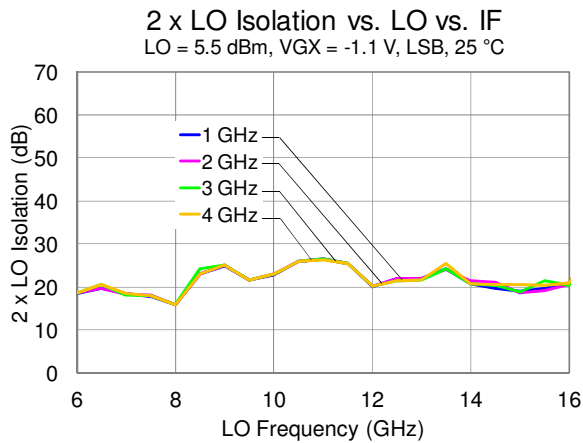
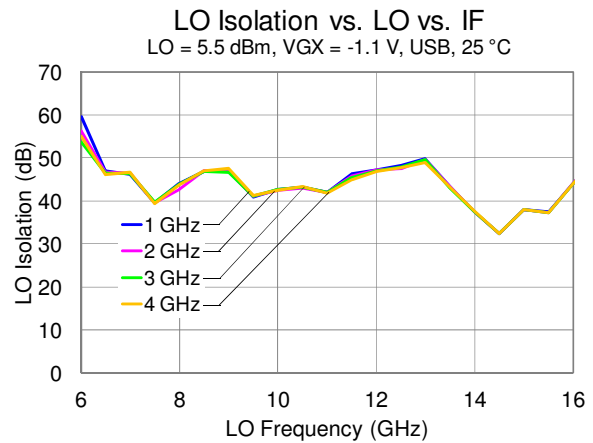
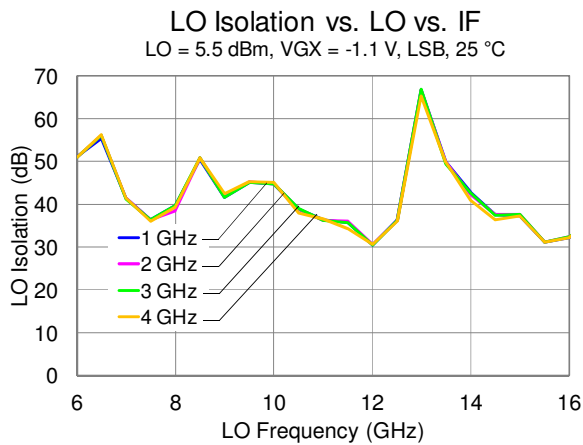
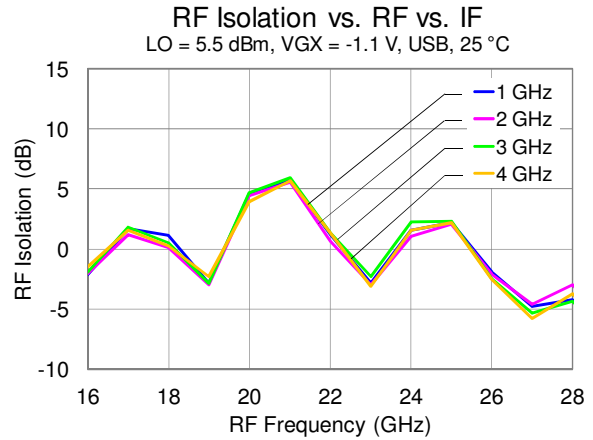
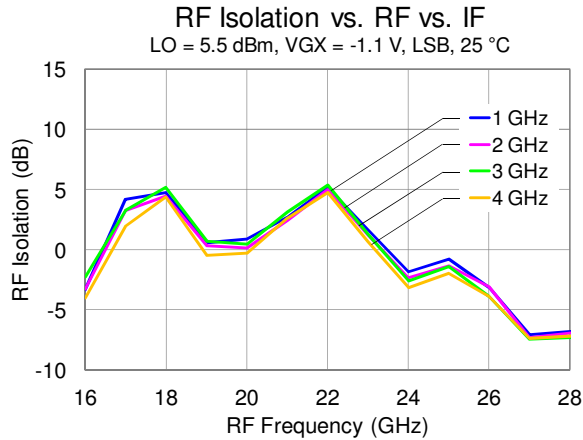

TGC4610-SM

K-Band Downconverter



Typical Performance

IF Input Power = -25 dBm, VDLO = 3 V, IDLO = 160 mA, VDRF = 3 V, IDRf = 68 mA, VGRF = -0.65 V.
 Data taken with external IF hybrid.

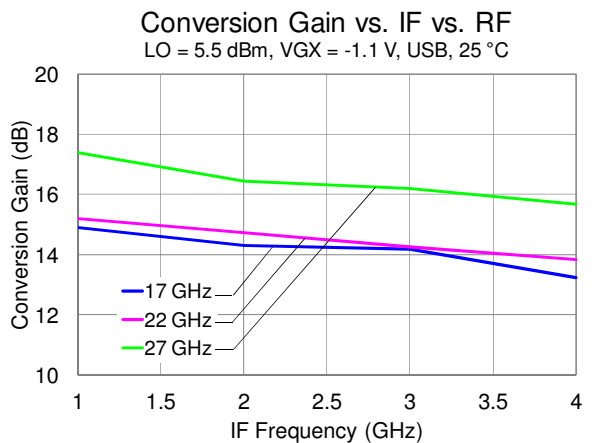
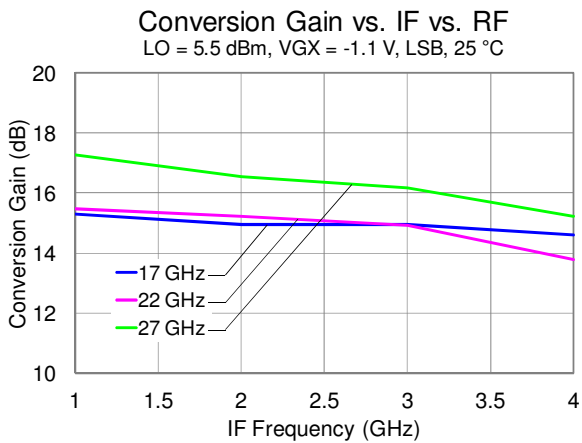
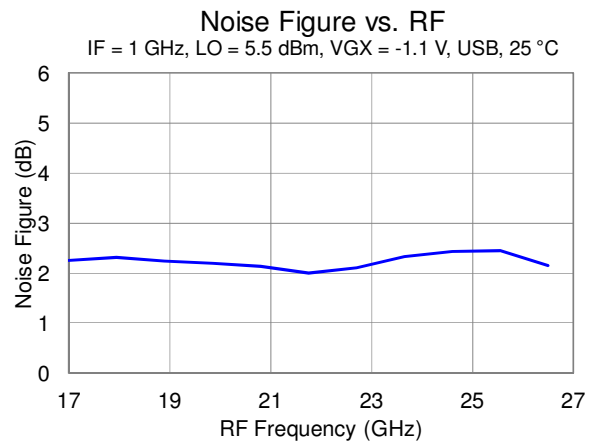
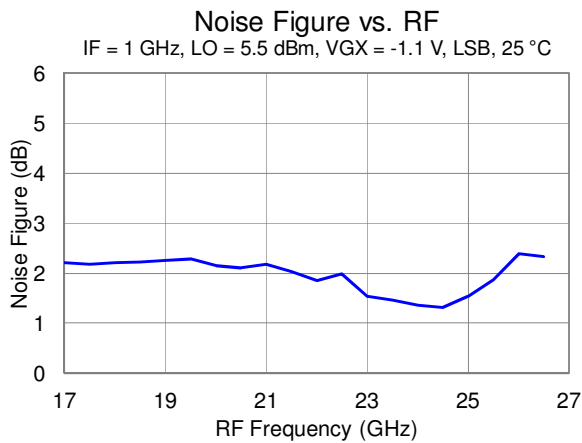
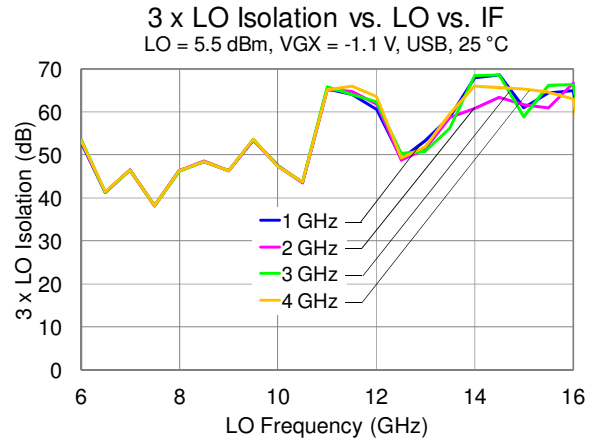
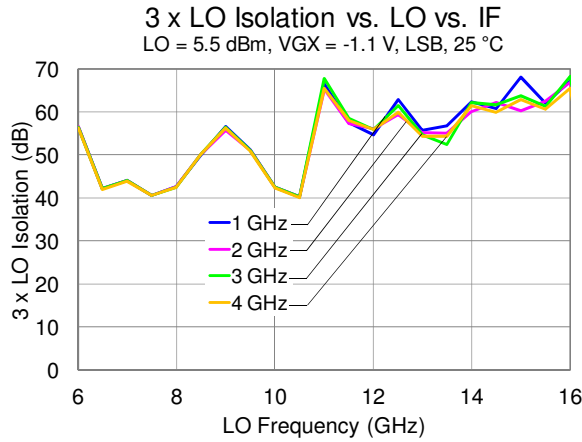

TGC4610-SM

K-Band Downconverter



Typical Performance

IF Input Power = -25 dBm, VDLO = 3 V, IDLO = 160 mA, VDRF = 3 V, IDRF = 68 mA, VGRF = -0.65 V.
 Data taken with external IF hybrid.

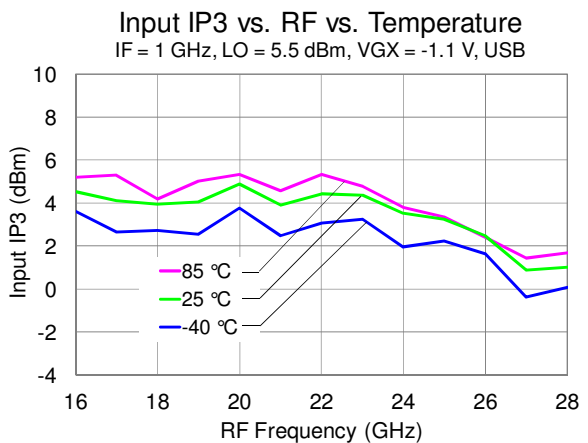
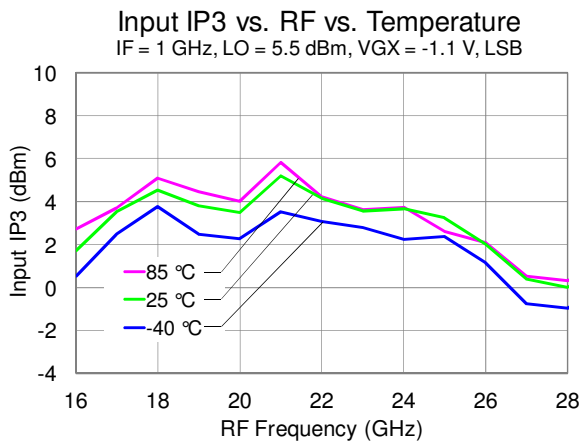
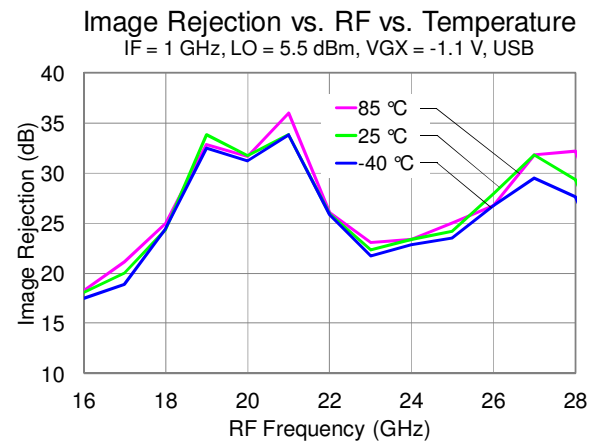
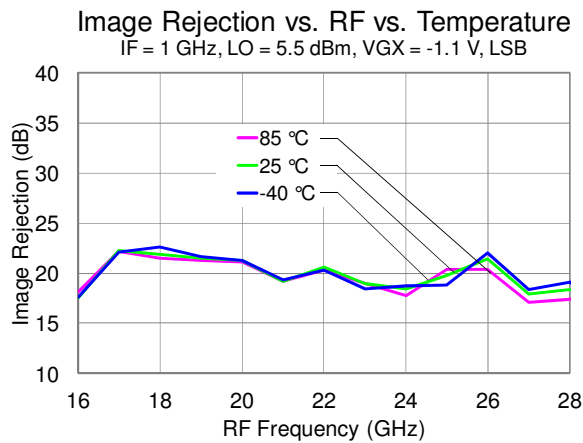
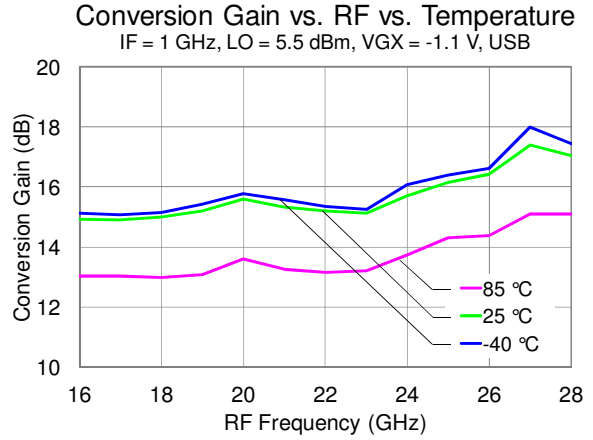
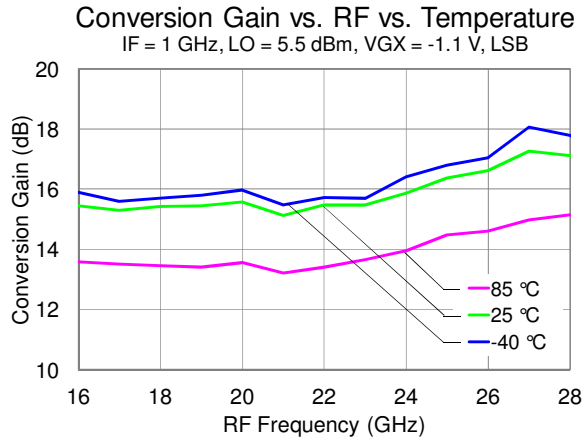

TGC4610-SM

K-Band Downconverter



Typical Performance

IF Input Power = -25 dBm, VDLO = 3 V, IDLO = 160 mA, VDRF = 3 V, IDRF = 68 mA, VGRF = -0.65 V.
 Data taken with external IF hybrid.

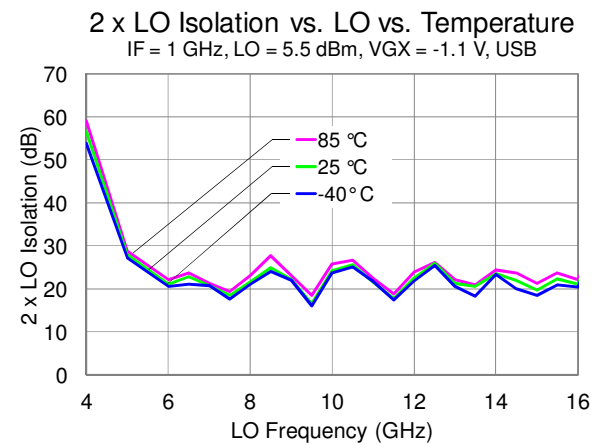
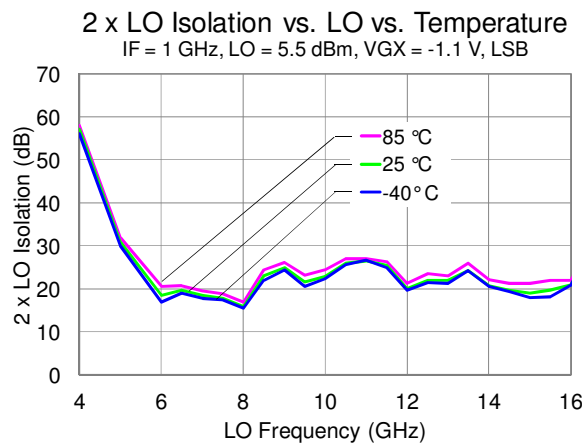
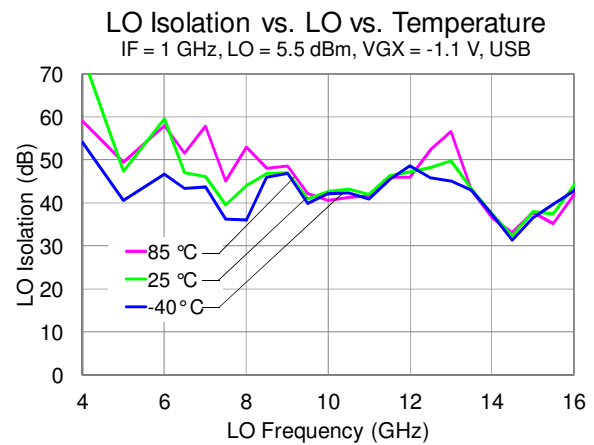
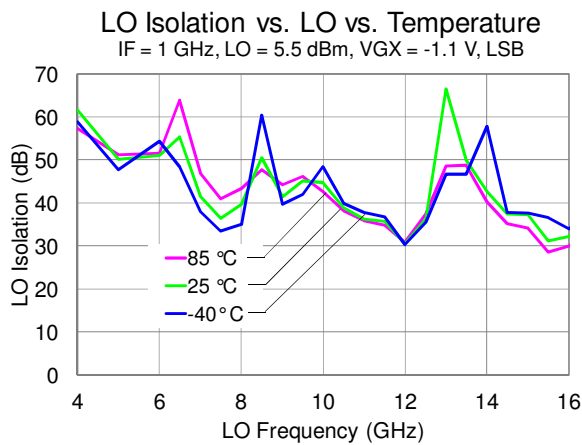
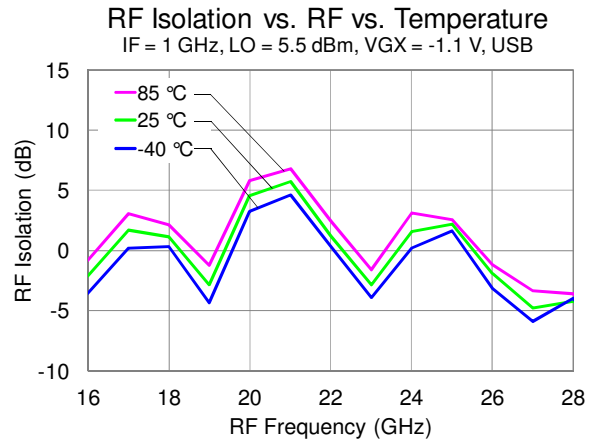
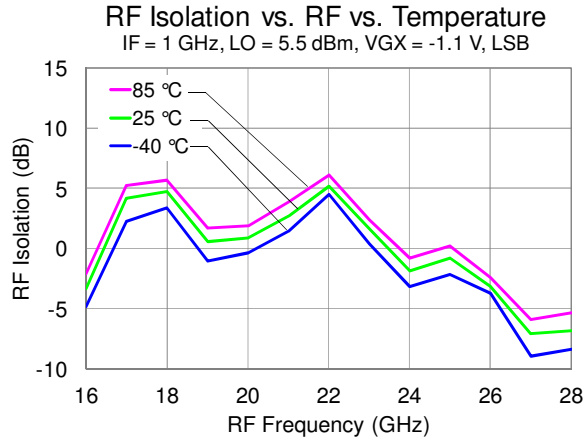

TGC4610-SM

K-Band Downconverter



Typical Performance

IF Input Power = -25 dBm, VDLO = 3 V, IDLO = 160 mA, VDRF = 3 V, IDRF = 68 mA, VGRF = -0.65 V.
 Data taken with external IF hybrid.

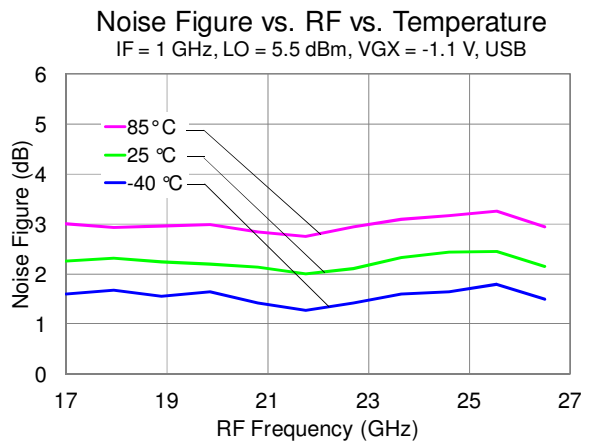
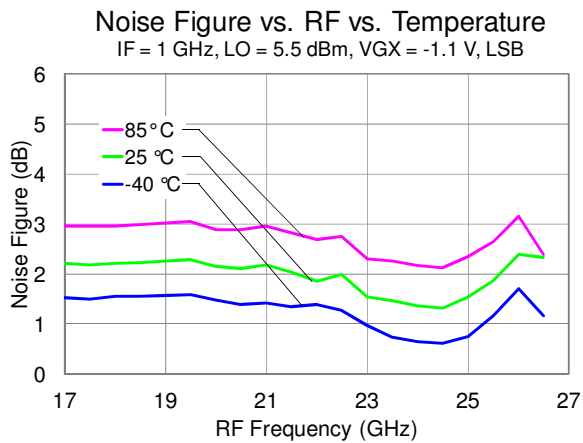
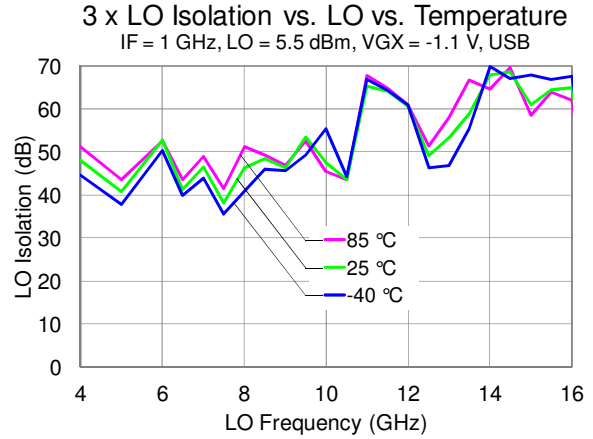
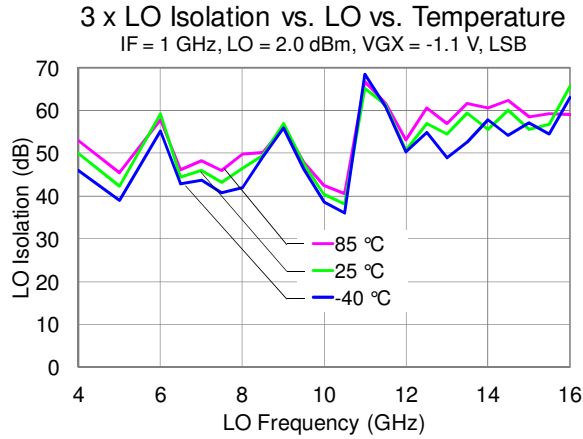

Typical Performance

IF Input Power = -25 dBm, VDLO = 3 V, IDLO = 160 mA, VDRF = 3 V, IDRf = 55 to 82 mA, VGRF = -0.7 to -0.6 V.
 Data taken with external IF hybrid.

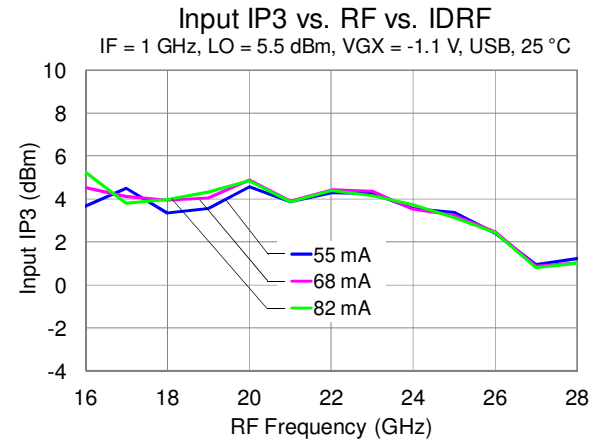
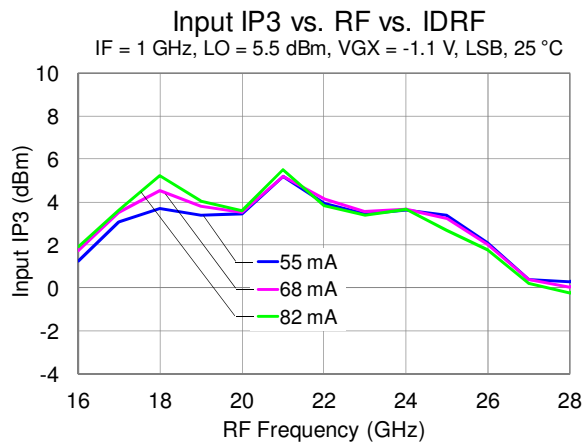
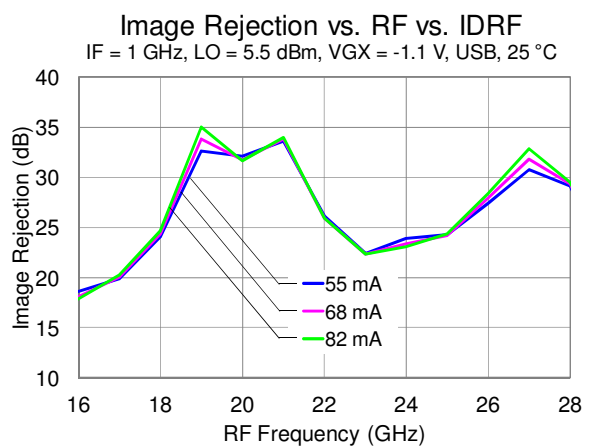
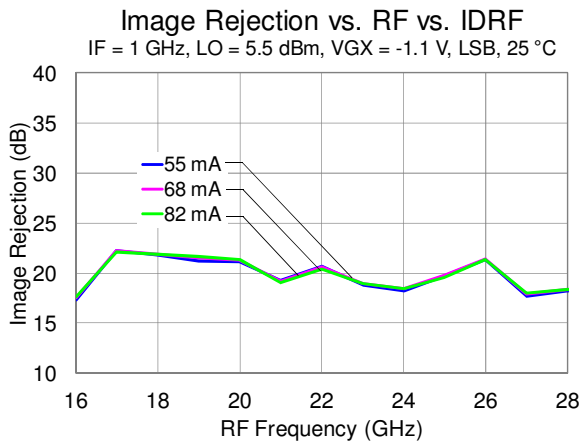
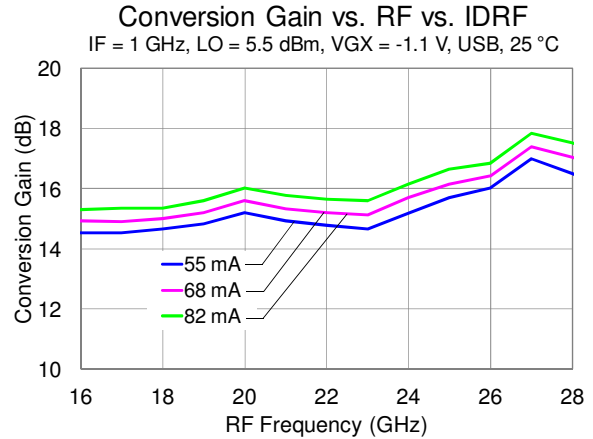
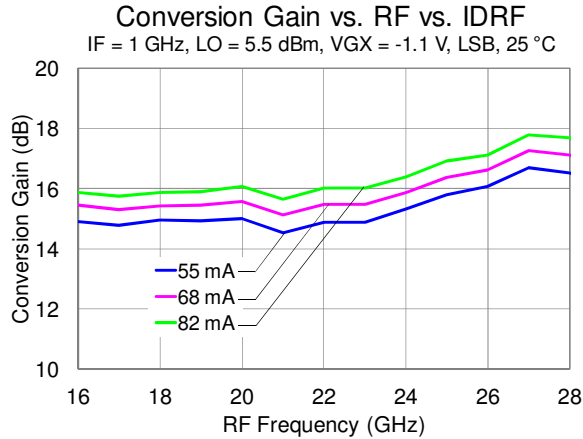

Typical Performance

IF Input Power = -25 dBm, VDLO = 3 V, IDLO = 160 mA, VDRF = 3 V, IDRf = 55 to 82 mA, VGRF = -0.7 to -0.6 V.
 Data taken with external IF hybrid.

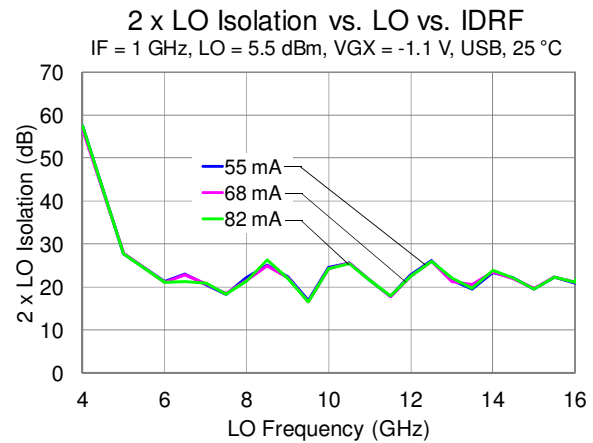
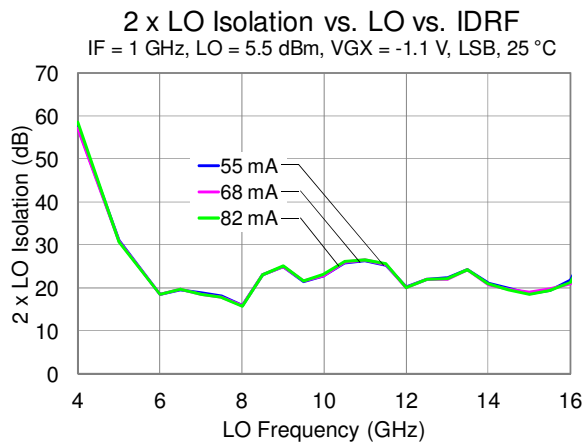
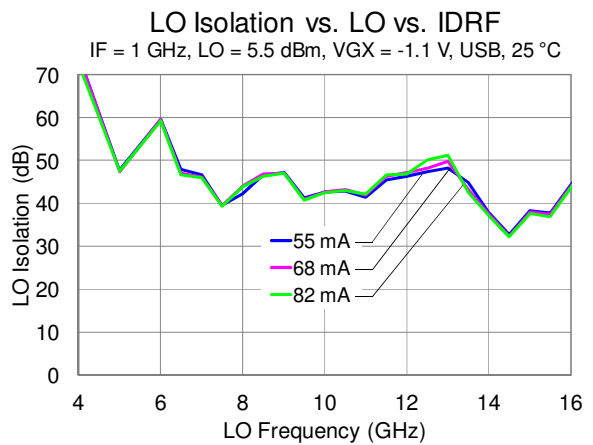
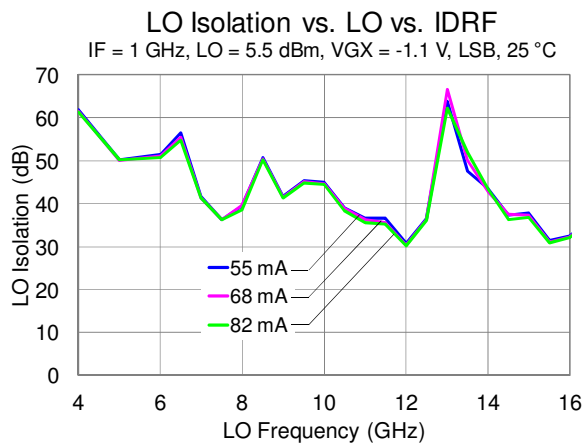
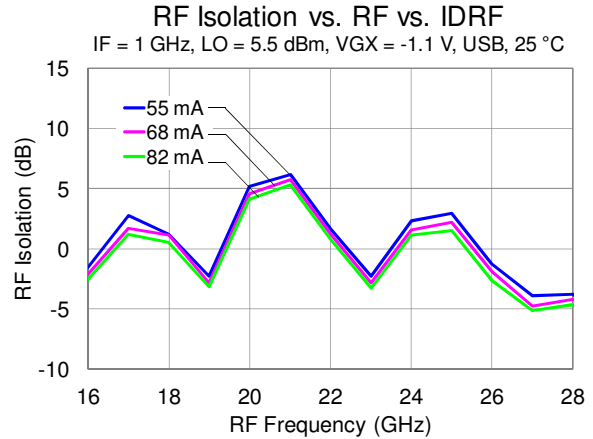
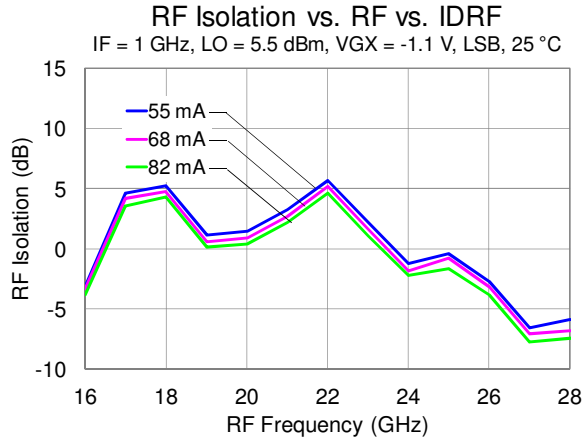

Typical Performance

IF Input Power = -25 dBm, VDLO = 3 V, IDLO = 160 mA, VDRF = 3 V, IDRF = 55 to 82 mA, VGRF = -0.7 to -0.6 V. Data taken with external IF hybrid.

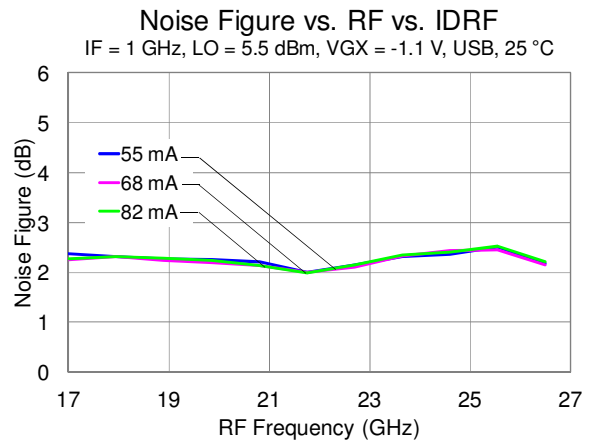
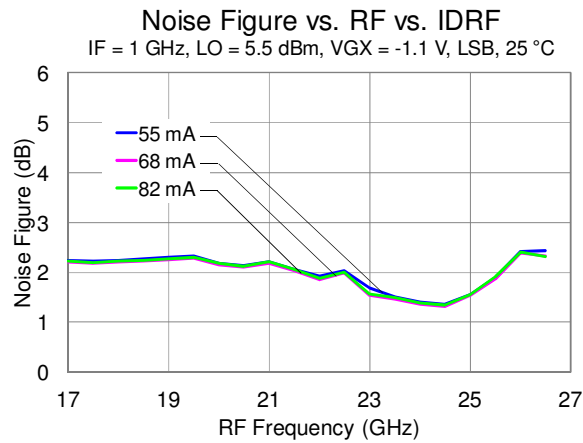
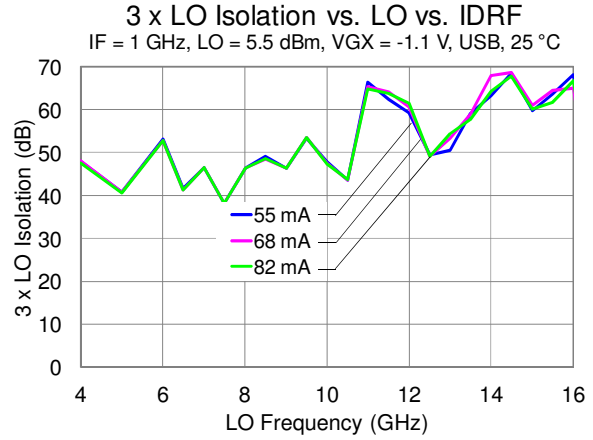
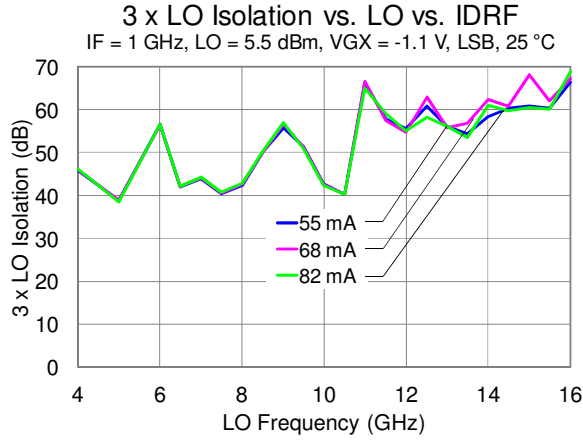

TGC4610-SM

K-Band Downconverter



Typical Performance

IF Input Power = -25 dBm, VDLO = 3 V, IDLO = 160 mA, VDRF = 3 V, IDRf = 68 mA, VGRF = -0.65 V.
 Data taken with external IF hybrid.

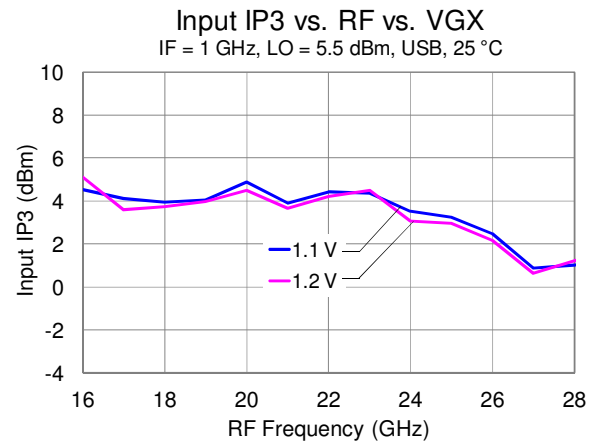
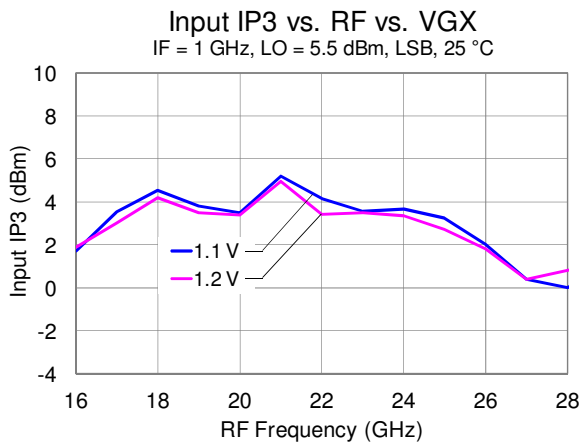
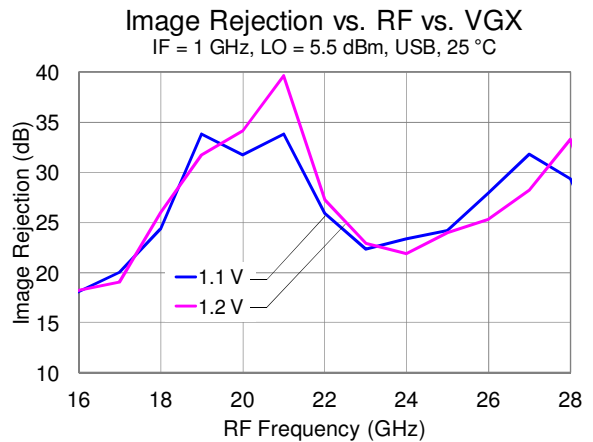
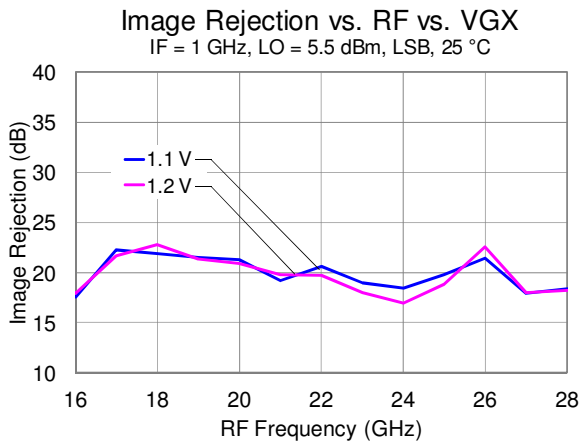
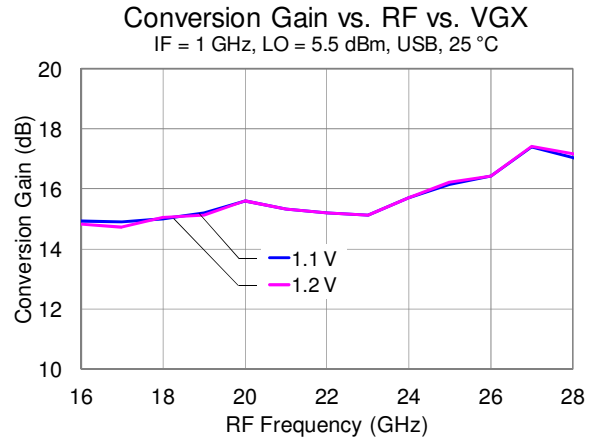
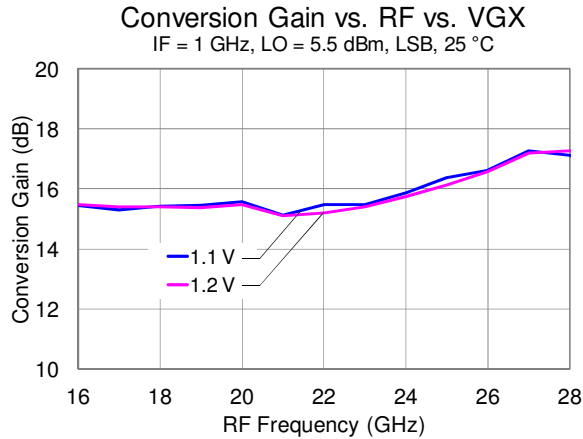

Typical Performance

IF Input Power = -25 dBm, VDLO = 3 V, IDLO = 160 mA, VDRF = 3 V, IDRF = 68 mA, VGRF = -0.65 V.
 Data taken with external IF hybrid.

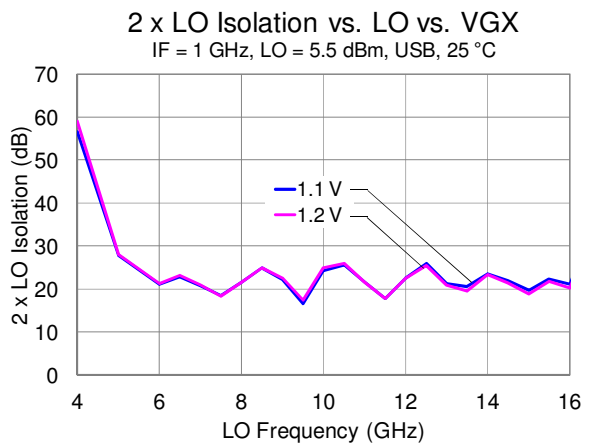
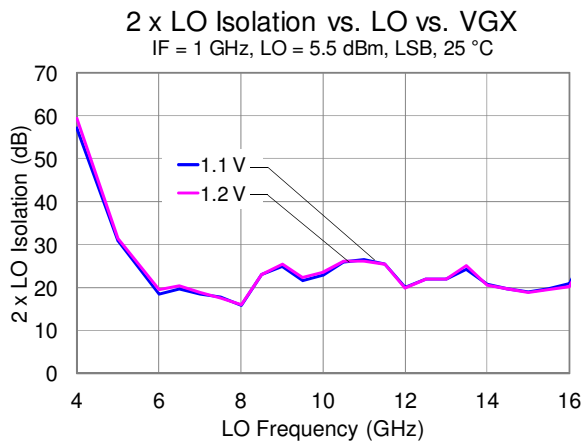
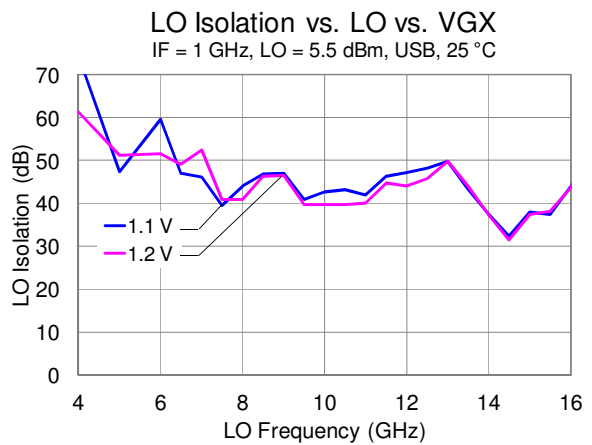
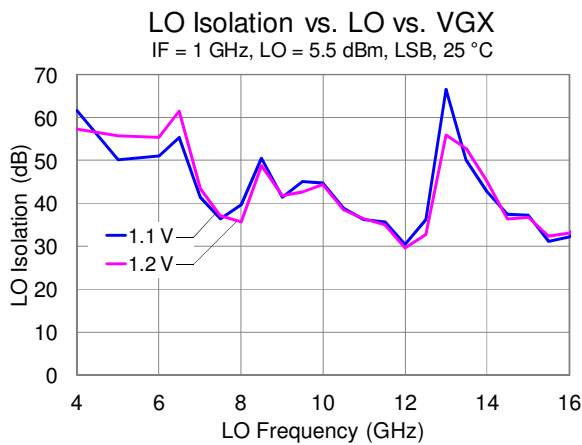
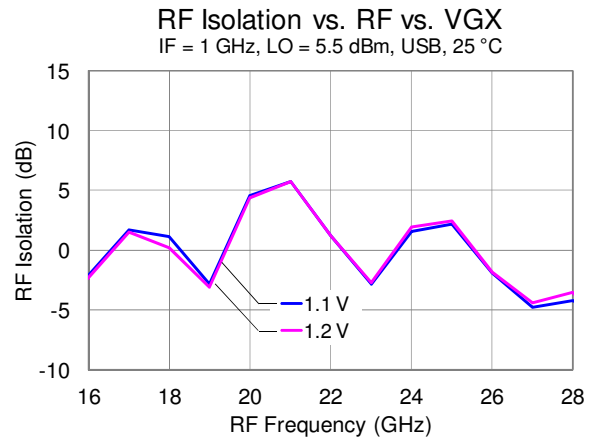
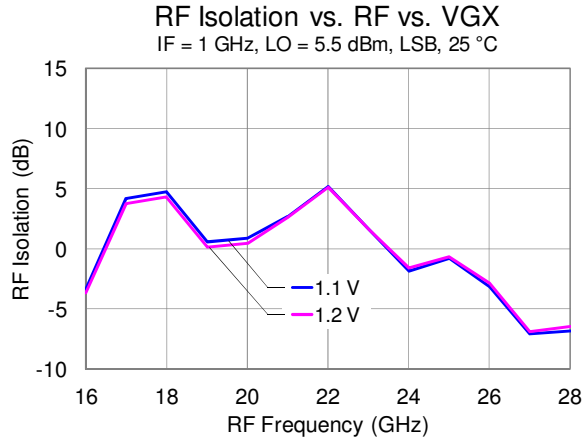

Typical Performance

IF Input Power = -25 dBm, VDLO = 3 V, IDLO = 160 mA, VDRF = 3 V, IDRF = 68 mA, VGRF = -0.65 V.
 Data taken with external IF hybrid.

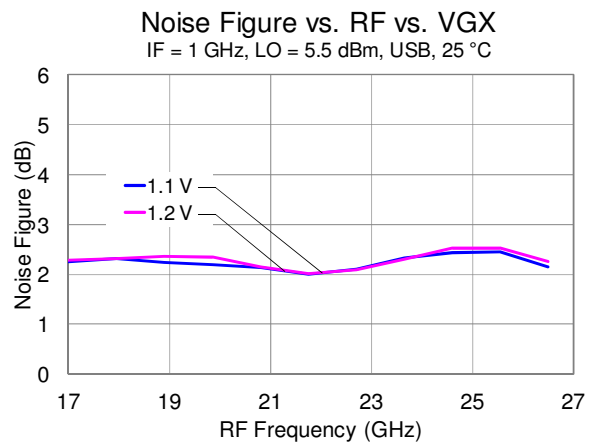
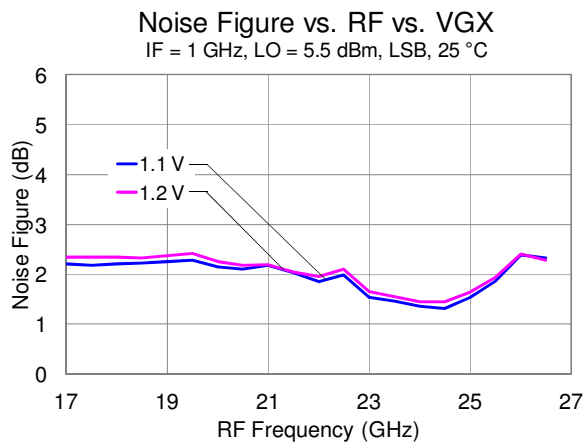
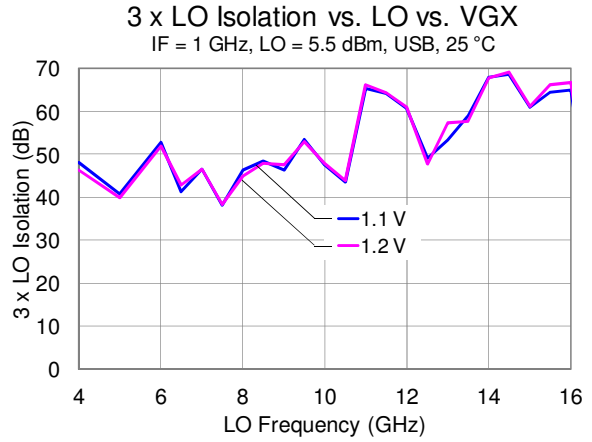
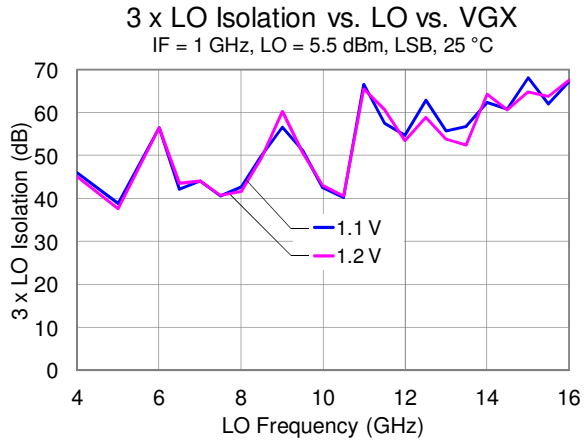

TGC4610-SM

K-Band Downconverter



Typical Performance

IF Input Power = -25 dBm, VDLO = 3 V, IDLO = 160 mA, VDRF = 3 V, IDRF = 68 mA, VGRF = -0.65 V.
 Data taken with external IF hybrid.

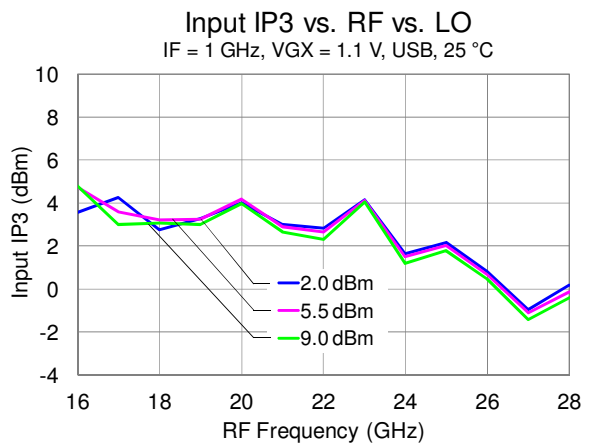
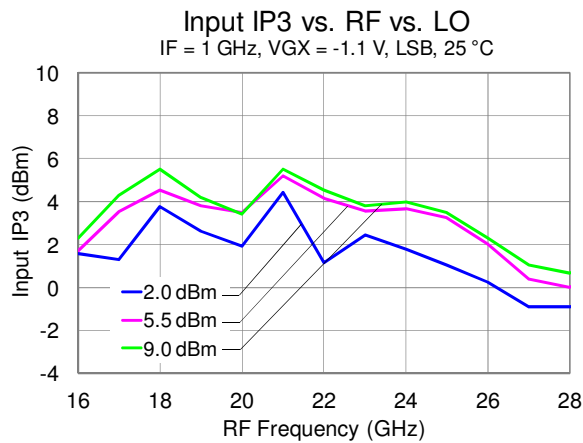
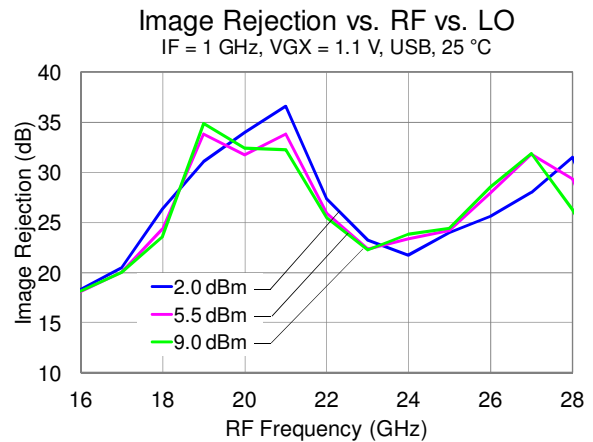
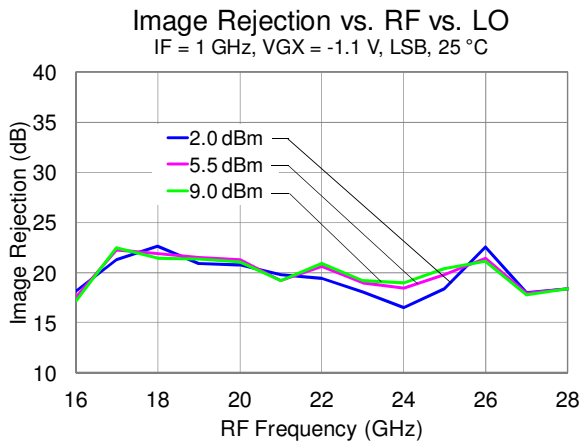
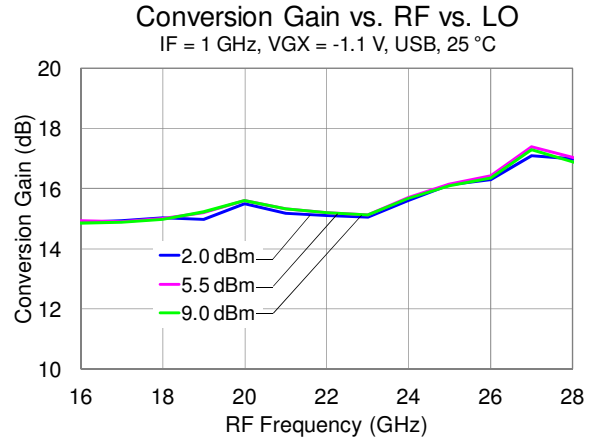
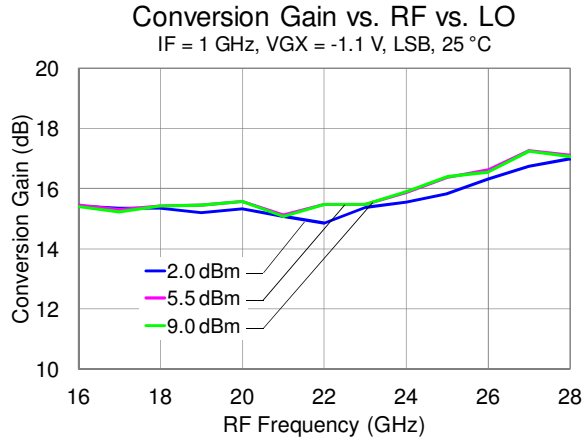

TGC4610-SM

K-Band Downconverter



Typical Performance

IF Input Power = -25 dBm, VDLO = 3 V, IDLO = 160 mA, VDRF = 3 V, IDRf = 68 mA, VGRF = -0.65 V.
 Data taken with external IF hybrid.

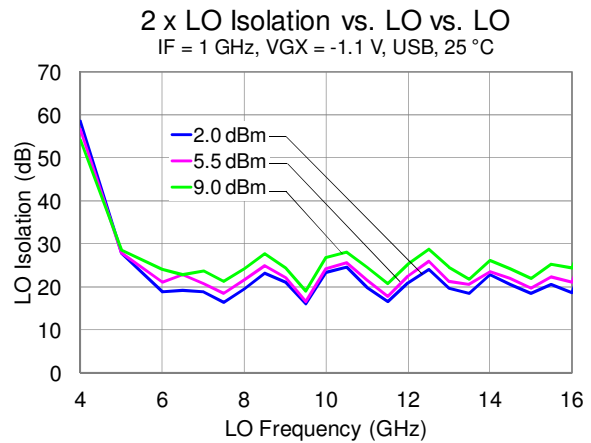
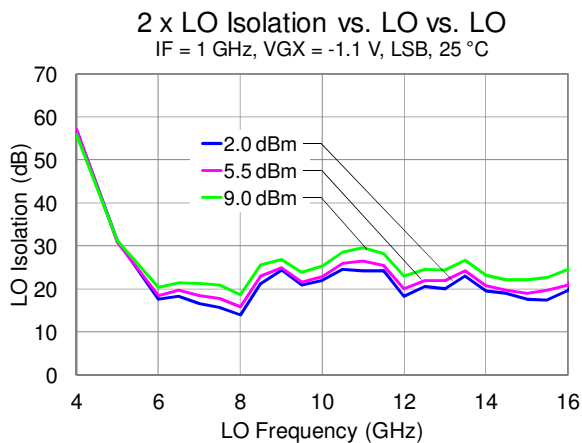
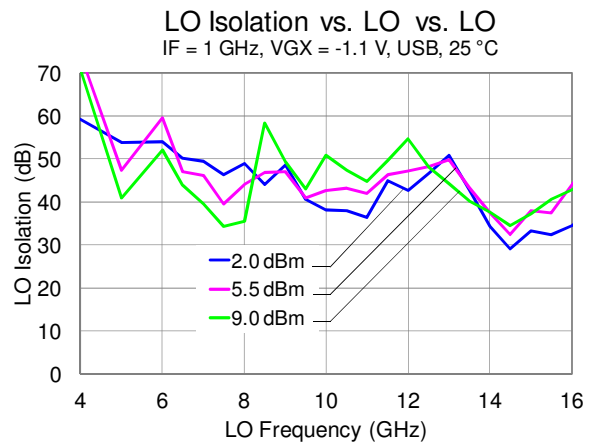
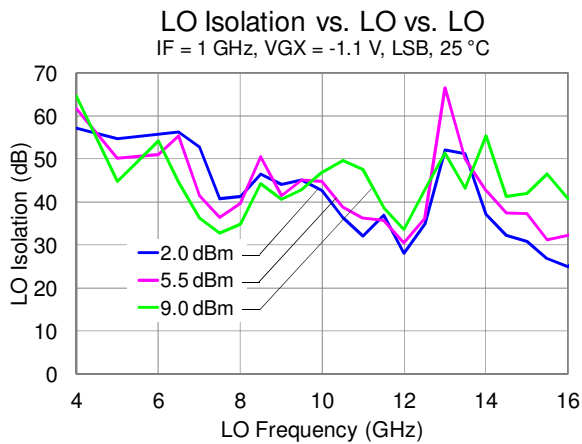
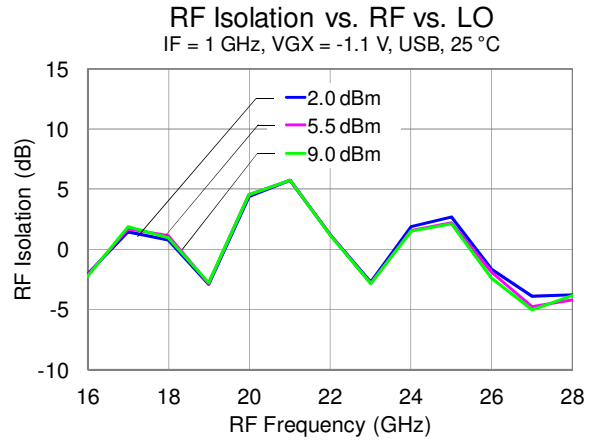
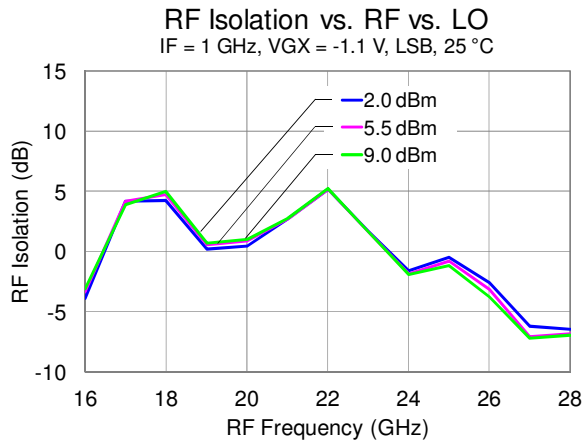

Typical Performance

IF Input Power = -25 dBm, VDLO = 3 V, IDLO = 160 mA, VDRF = 3 V, IDRf = 68 mA, VGRF = -0.65 V.
 Data taken with external IF hybrid.

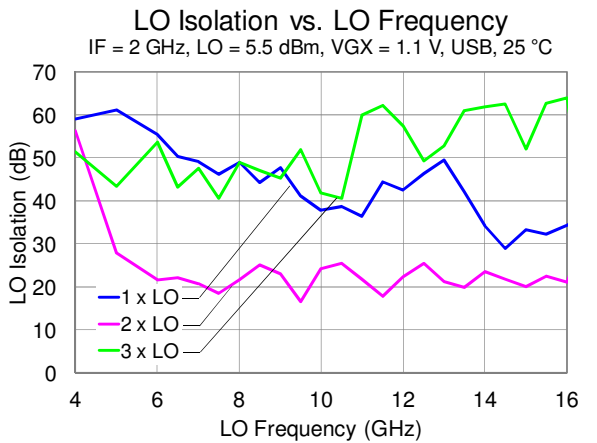
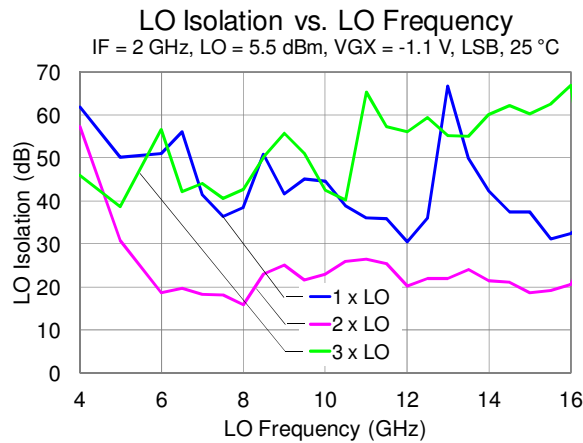
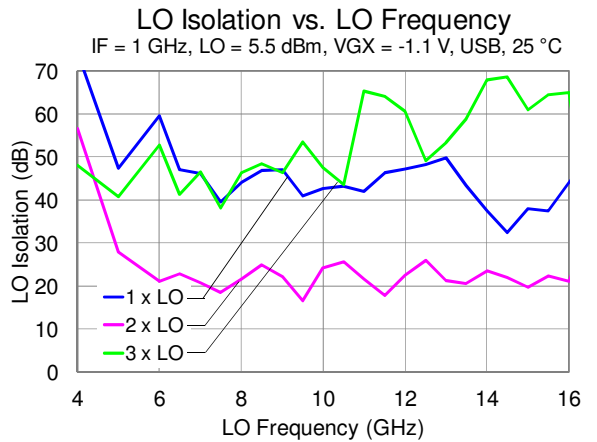
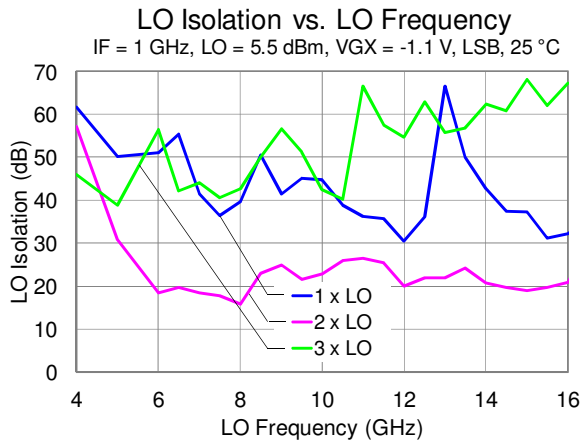
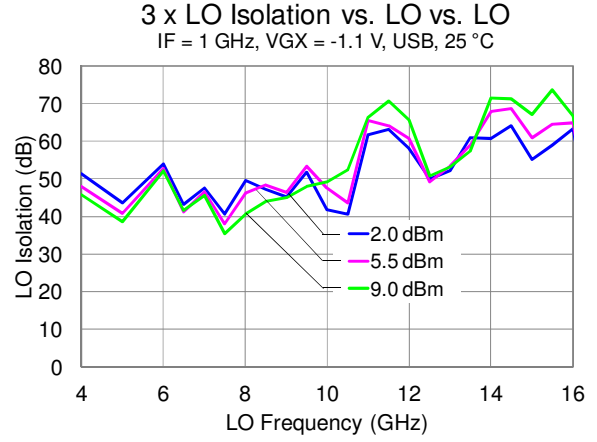
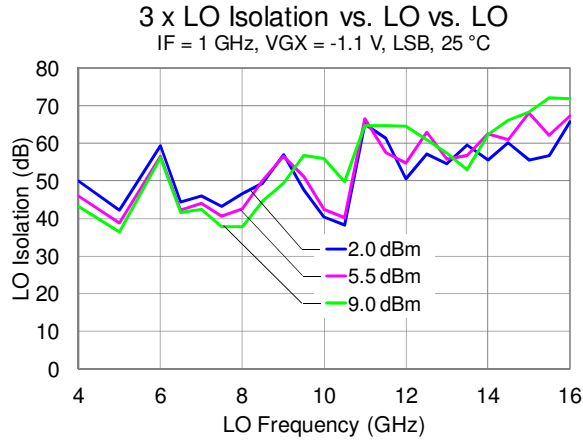

Typical Performance

IF Input Power = -25 dBm, VDLO = 3 V, IDLO = 160 mA, VDRF = 3 V, IDRf = 68 mA, VGRF = -0.65 V.
 Data taken with external IF hybrid.

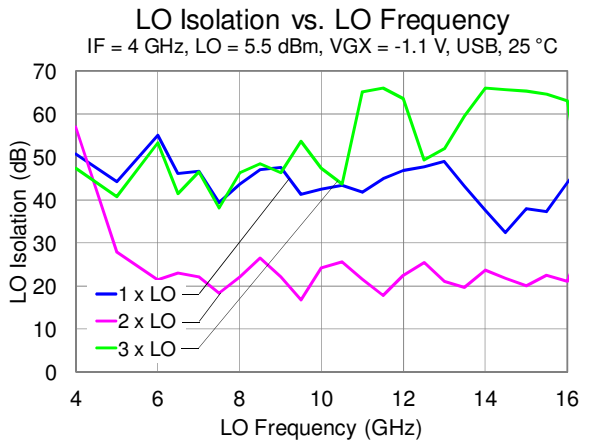
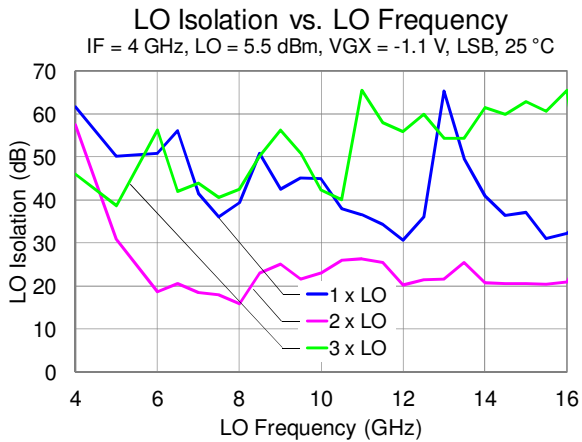
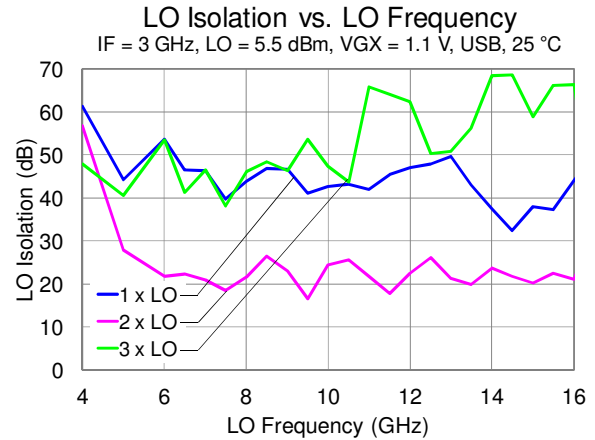
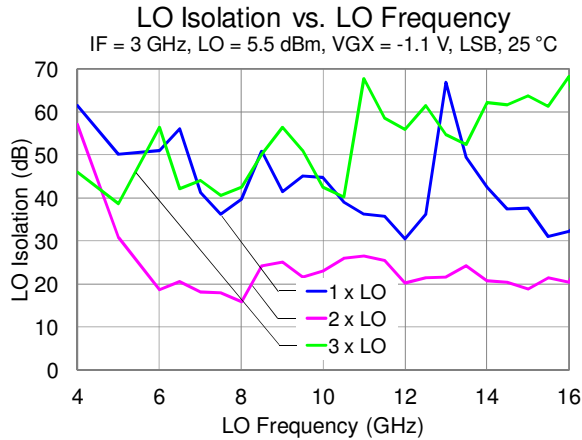

M x N Spurious Outputs for USB

IF = 2.0 GHz; RF = 17 - 27 GHz; LO = 7.5 - 12.5 GHz				
RF/LO	0	1	2	3
-3	---	49	52	51
-2	---	56	57	63
-1	---	28	0	26
0	---	12	0	14
1	10	44	23	47
2	52	50	51	---

IF = 4.0 GHz; RF = 17 - 27 GHz; LO = 6.5 - 11.5 GHz				
RF/LO	0	1	2	3
-3	---	47	50	---
-2	---	53	56	56
-1	---	30	0	32
0	---	10	-2	13
1	10	39	21	49
2	51	51	51	---

Pin Description

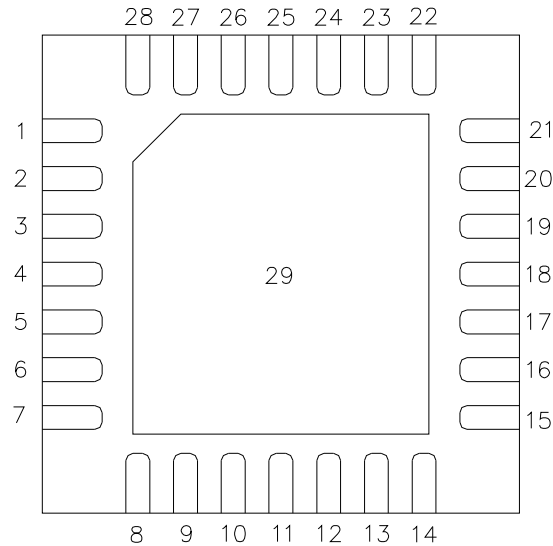

TOP VIEW

Pin	Symbol	Description
1, 2, 4, 5, 6, 7, 8, 12, 14, 15, 16, 20, 21, 22, 25, 26, 28	GND	Internal Grounding; must be grounded on PCB.
3	RF IN	RF Input matched to 50 ohms, AC Coupled.
9	LO IN	LO Input, matched to 50 ohms, AC coupled.
10	VDLO1	LO Drain Voltage. Bias network is required; see Application Circuit on page 21 as an example.
11	VGX	LO Gate Voltage. Bias network is required; see Application Circuit on page 21 as an example.
13	VDLO23	LO Drain Voltage. Bias network is required; see Application Circuit on page 21 as an example.
17	IF1	IF Output matched to 50 ohms, DC coupled.
18	NC	No internal connection; should be left open.
19	IF2	IF Output matched to 50 ohms, DC coupled.
23	VDRF4V	RF Drain Voltage for 4 V operation. Bias network is required; see Application Circuit on page 21 as an example.
24	VDRF	RF Drain Voltage. Bias network is required; see Application Circuit on page 21 as an example.
27	VGRF	RF Gate Voltage. Bias network is required; see Application Circuit on page 21 as an example.
29	GND	Backside Paddle. Multiple vias should be employed to minimize inductance and thermal resistance; see Mounting Configuration on page 24 for suggested footprint.

Application Circuit

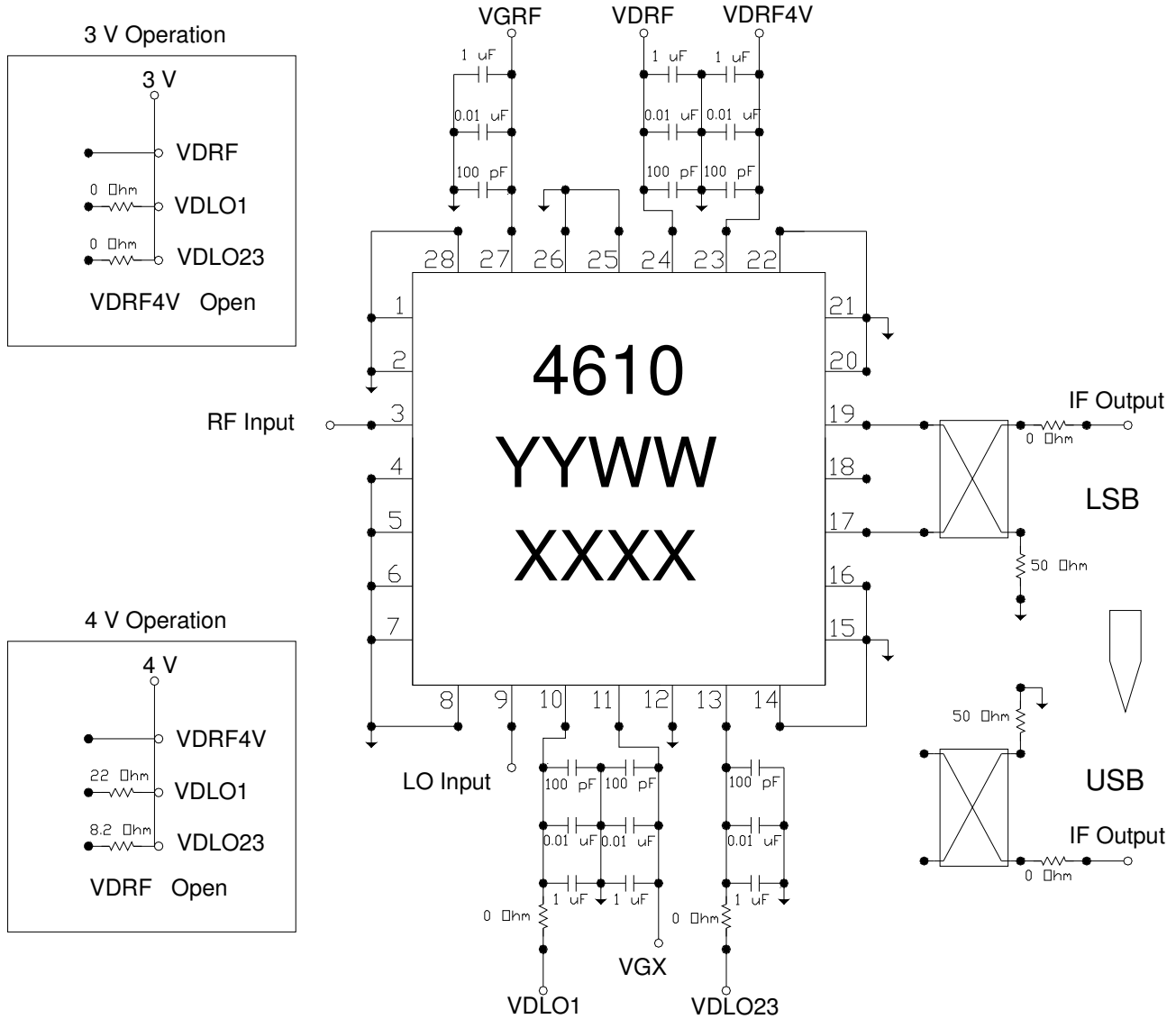

Biasing Procedures

Bias up

- Set VGX to -1.1 V
- Set VDLO to 3 V
- Set VGRF to -1.5 V
- Set VDRF to 3 V
- Increase VGRF to get IDRF = 68 mA
- Apply RF signal

Bias Down

- Turn off RF signal
- Set VDRF to 0 V
- Set VDLO to 0 V
- Set VGRF to 0 V
- Set VGX to 0 V

Application Circuit

PC Board Layout

Board material is RO4003 0.008" thickness with 1/2 oz copper cladding.
 For further technical information, refer to the [TGC4610-SM](#) Product Information page.

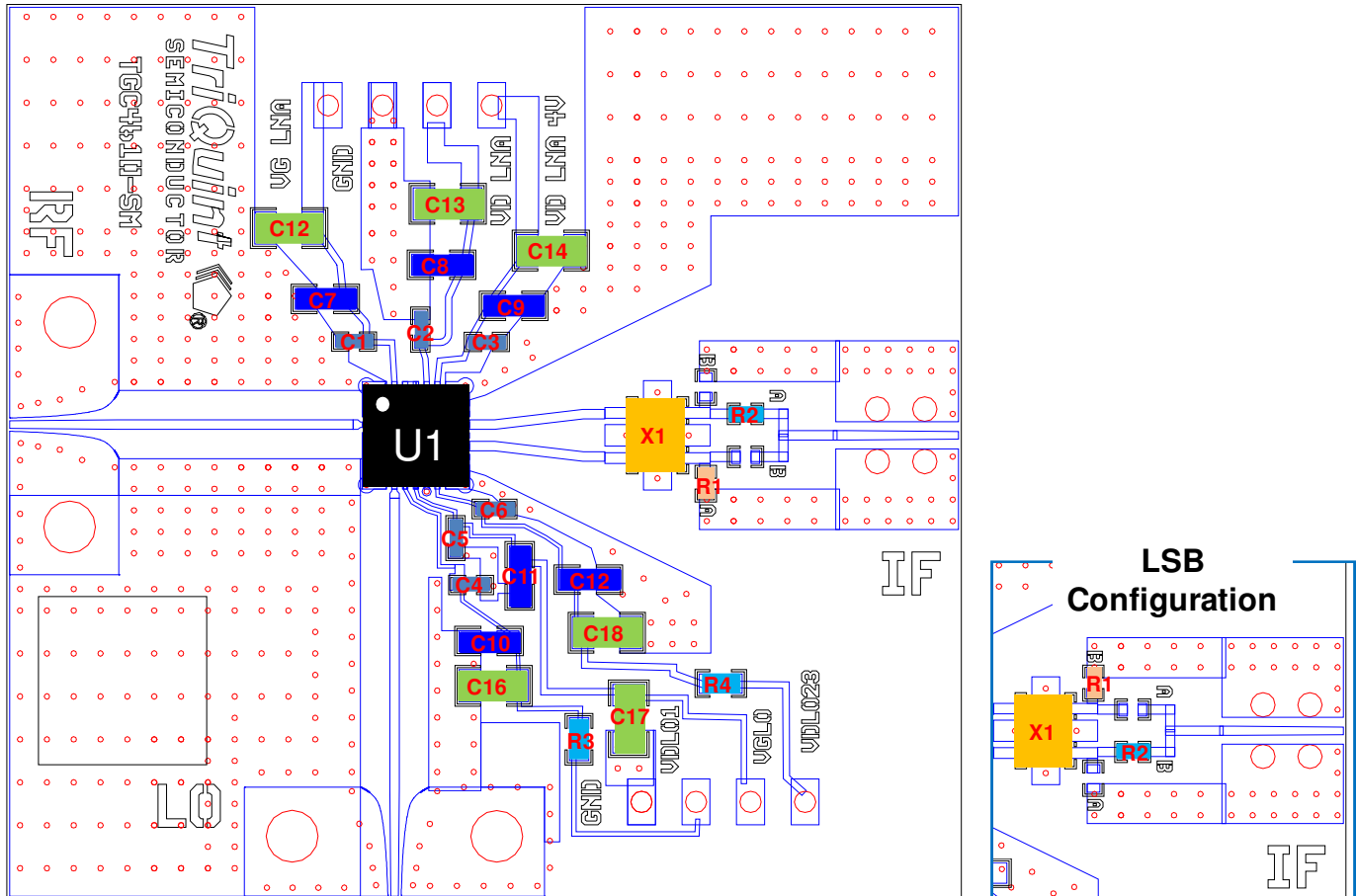

Bill of Material

Ref Des	Value	Description	Manufacturer	Part Number
C1 – C6	100 pF	Cap, 0402, 50V, 5%, NPO	various	
C7 – C12	0.01 μ F	Cap, 0603, 25V, 5%, COG	various	
C13 – C18	1 μ F	Cap, 0805, 25V, 5%, X5R	various	
R1	50 Ω	Res, 0402, 0.05W, 0.1%, SMD	various	
R2 – R4	0 Ω	Res, 0402, 0.01W, SMD	various	
X1		Power Splitter	Mini-Circuits	QCN-19+ or QCN45+
U1		K-Band Downconverter	TriQuint	TGC4610-SM

Note: For 4 V operation, R3 = 22 Ω and R4 = 8.2 Ω .

Mechanical Information

Package Information and Dimensions

All dimensions are in millimeters.

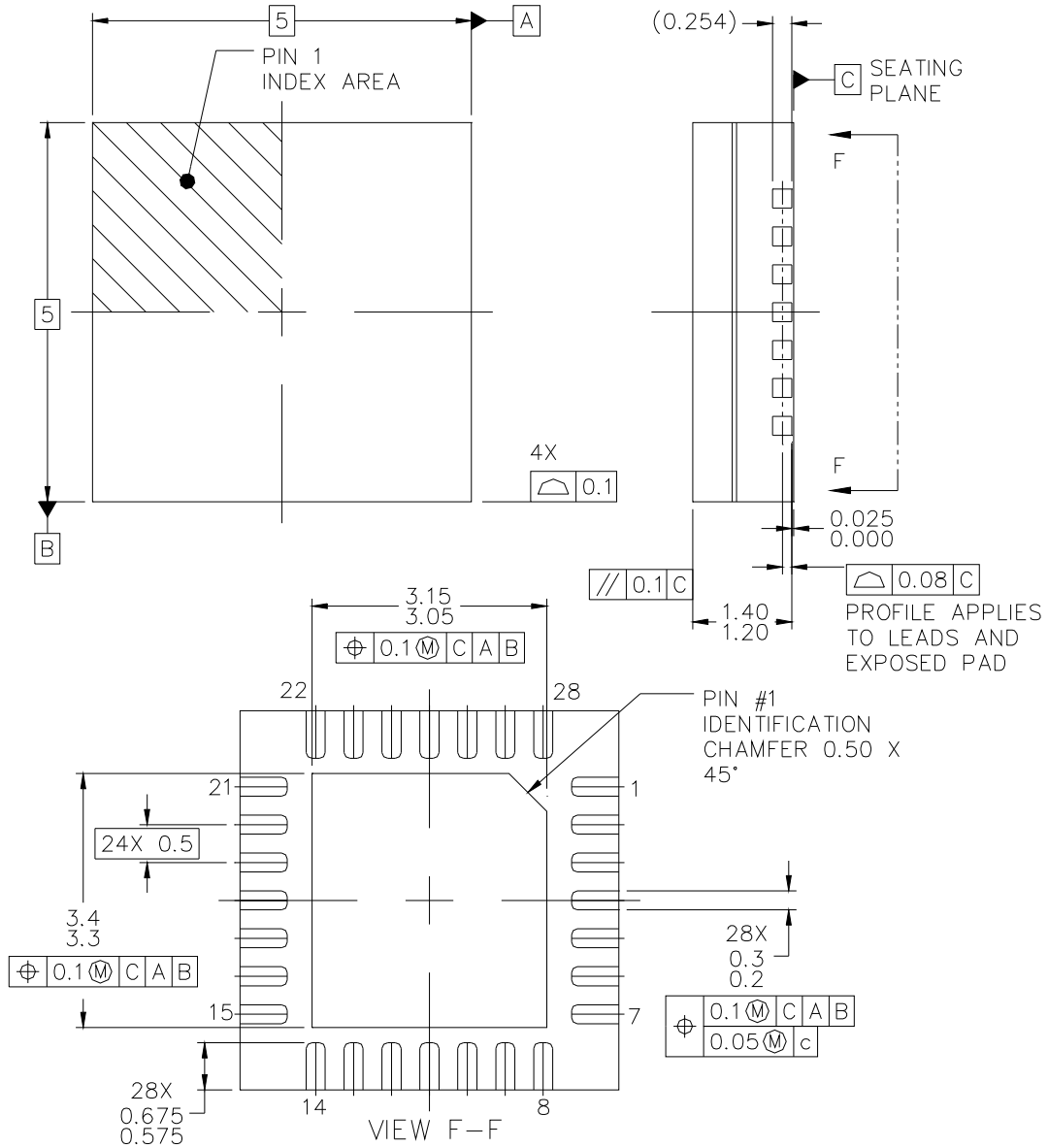

The TGC4610-SM will be marked with the “4610” designator and a lot code marked below the part designator. The “YY” represents the last two digits of the year the part was manufactured, the “WW” is the work week, and the “XXXX” is an auto-generated number.

This package is lead-free/RoHS-compliant with a copper alloy base (CDA194), and the plating material on the leads is NiPdAu. It is compatible with lead-free (maximum 260 °C reflow temperature) soldering processes.

Mechanical Information

PCB Mounting Pattern

All dimensions are in millimeters.

Notes:

1. The pad pattern shown has been developed and tested for optimized assembly at TriQuint Semiconductor. The PCB land pattern has been developed to accommodate lead and package tolerances. Since surface mount processes vary from company to company, careful process development is recommended.
2. Ground / thermal vias are critical for the proper performance of this device. Vias should use a .35mm diameter drill and have a final plated thru diameter of .25 mm.

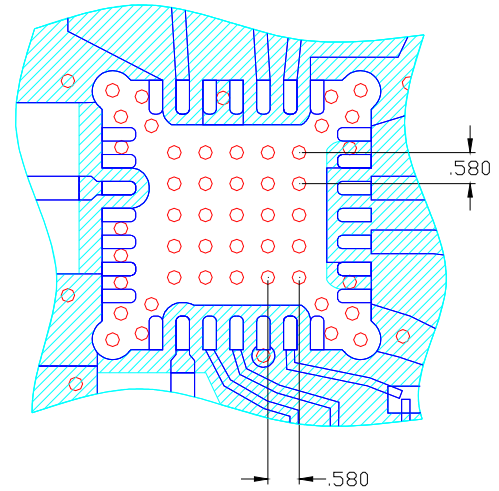

Tape and Reel Information

Tape and reel specifications for this part are also available on the TriQuint website in the “Application Notes” section.

Standard T/R size = 500 pieces on a 13” reel.

MATERIAL		CAVITY (mm)				DISTANCE BETWEEN CENTERLINE (mm)		CARRIER TAPE (mm)	COVER TAPE (mm)
Vendor	Vendor P/N	Length (A0)	Width (B0)	Depth (K0)	Pitch (P1)	Length direction (P2)	Width Direction (F)	Width (W)	Width (W)
Advantek	BCC5X5-B	5.25	5.25	1.8	8.0	2.00	5.50	12.0	9.20

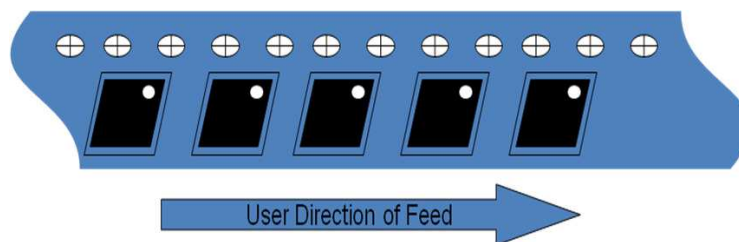
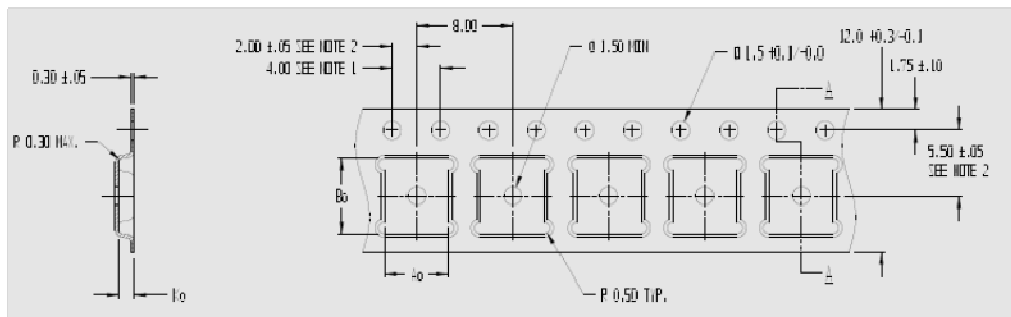

Product Compliance Information

ESD Information



Caution! ESD-Sensitive Device

ESD Rating: 1A
 Value: Passes ≥ 250 V and < 500 V.
 Test: Human Body Model (HBM)
 Standard: JEDEC Standard JESD22-A114

MSL Rating

Moisture Sensitivity Level (MSL) MSL1 at 260 °C convection reflow per JEDEC standard IPC/JEDEC J-STD-020.

Solderability

Compatible with lead-free soldering processes, 260° maximum reflow temperature.

Package lead plating: NiPdAu

The use of no-clean solder to avoid washing after soldering is recommended.

This package is not compatible with solder containing lead.

RoHS Compliance

This part is compliant with EU 2002/95/EC RoHS directive (Restrictions on the Use of Certain Hazardous Substances in Electrical and Electronic Equipment).

This product also has the following attributes:

- Lead Free
- Halogen Free (Chlorine, Bromine)
- Antimony Free
- TBBP-A (C₁₅H₁₂Br₄O₂) Free
- PFOS Free
- SVHC Free

Recommended Soldering Temperature Profile

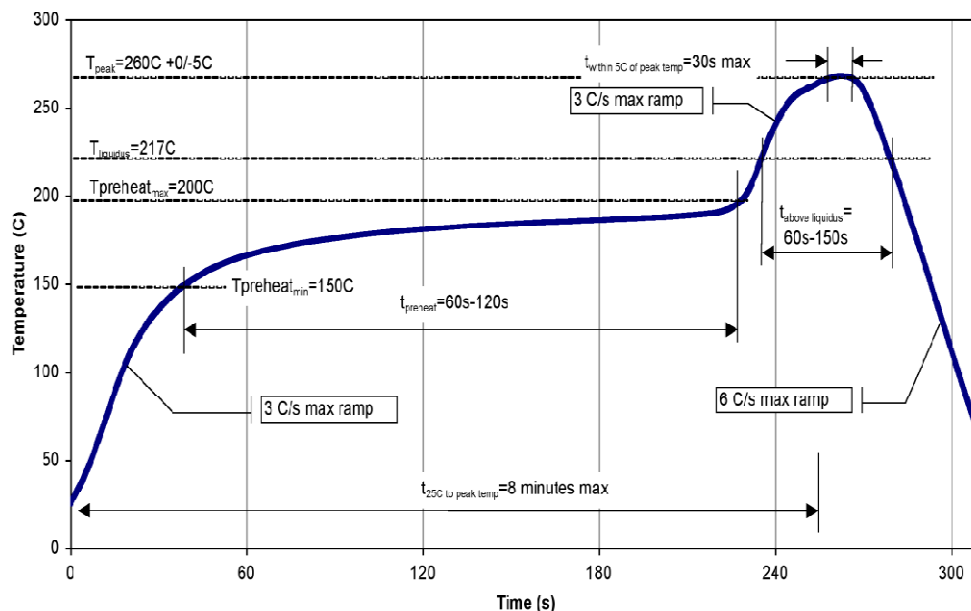

TGC4610-SM

K-Band Downconverter



Contact Information

For the latest specifications, additional product information, worldwide sales and distribution locations, and information about TriQuint:

Web: www.triquint.com
Email: info-sales@tqs.com

Tel: +1.972.994.8465
Fax: +1.972.994.8504

For technical questions and application information:

Email: info-networks@tqs.com

Important Notice

The information contained herein is believed to be reliable. TriQuint makes no warranties regarding the information contained herein. TriQuint assumes no responsibility or liability whatsoever for any of the information contained herein. TriQuint assumes no responsibility or liability whatsoever for the use of the information contained herein. The information contained herein is provided "AS IS, WHERE IS" and with all faults, and the entire risk associated with such information is entirely with the user. All information contained herein is subject to change without notice. Customers should obtain and verify the latest relevant information before placing orders for TriQuint products. The information contained herein or any use of such information does not grant, explicitly or implicitly, to any party any patent rights, licenses, or any other intellectual property rights, whether with regard to such information itself or anything described by such information.

TriQuint products are not warranted or authorized for use as critical components in medical, life-saving, or life-sustaining applications, or other applications where a failure would reasonably be expected to cause severe personal injury or death.